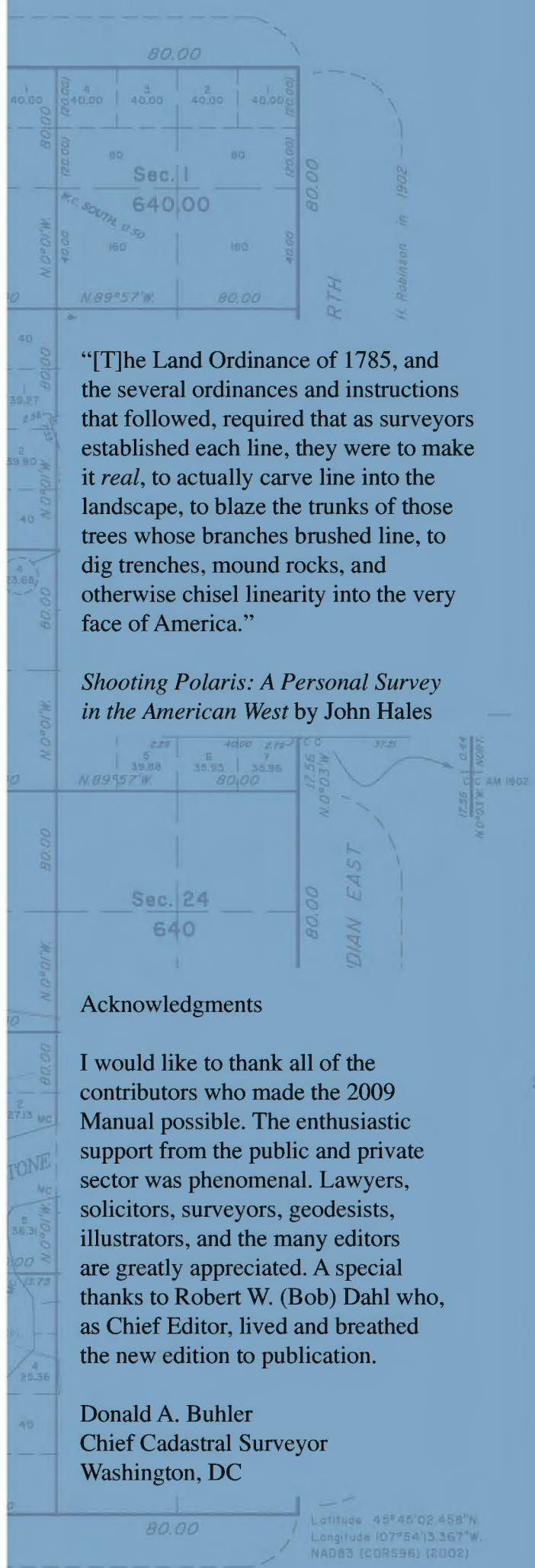


# Manual of Surveying Instructions



**2009**



“[T]he Land Ordinance of 1785, and the several ordinances and instructions that followed, required that as surveyors established each line, they were to make it *real*, to actually carve line into the landscape, to blaze the trunks of those trees whose branches brushed line, to dig trenches, mound rocks, and otherwise chisel linearity into the very face of America.”

*Shooting Polaris: A Personal Survey in the American West* by John Hales

### Acknowledgments

I would like to thank all of the contributors who made the 2009 Manual possible. The enthusiastic support from the public and private sector was phenomenal. Lawyers, solicitors, surveyors, geodesists, illustrators, and the many editors are greatly appreciated. A special thanks to Robert W. (Bob) Dahl who, as Chief Editor, lived and breathed the new edition to publication.

Donald A. Buhler  
Chief Cadastral Surveyor  
Washington, DC





N° 30.

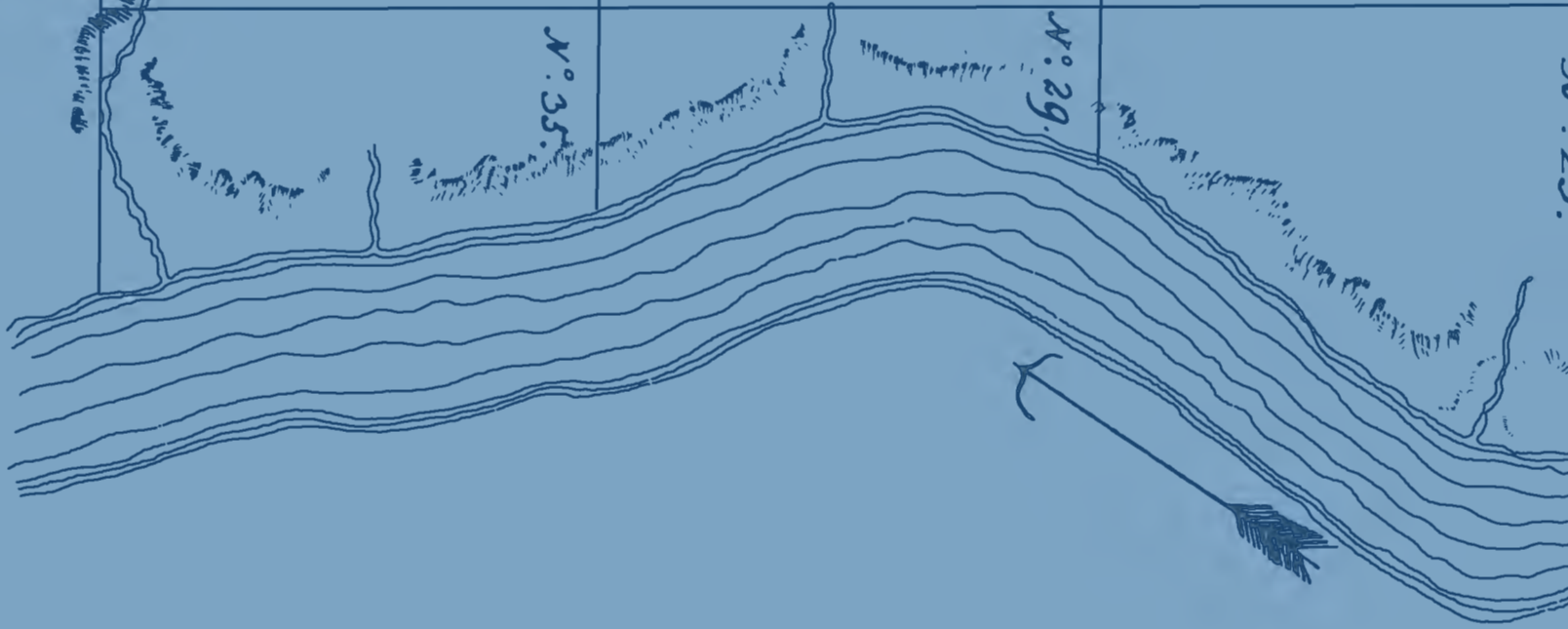


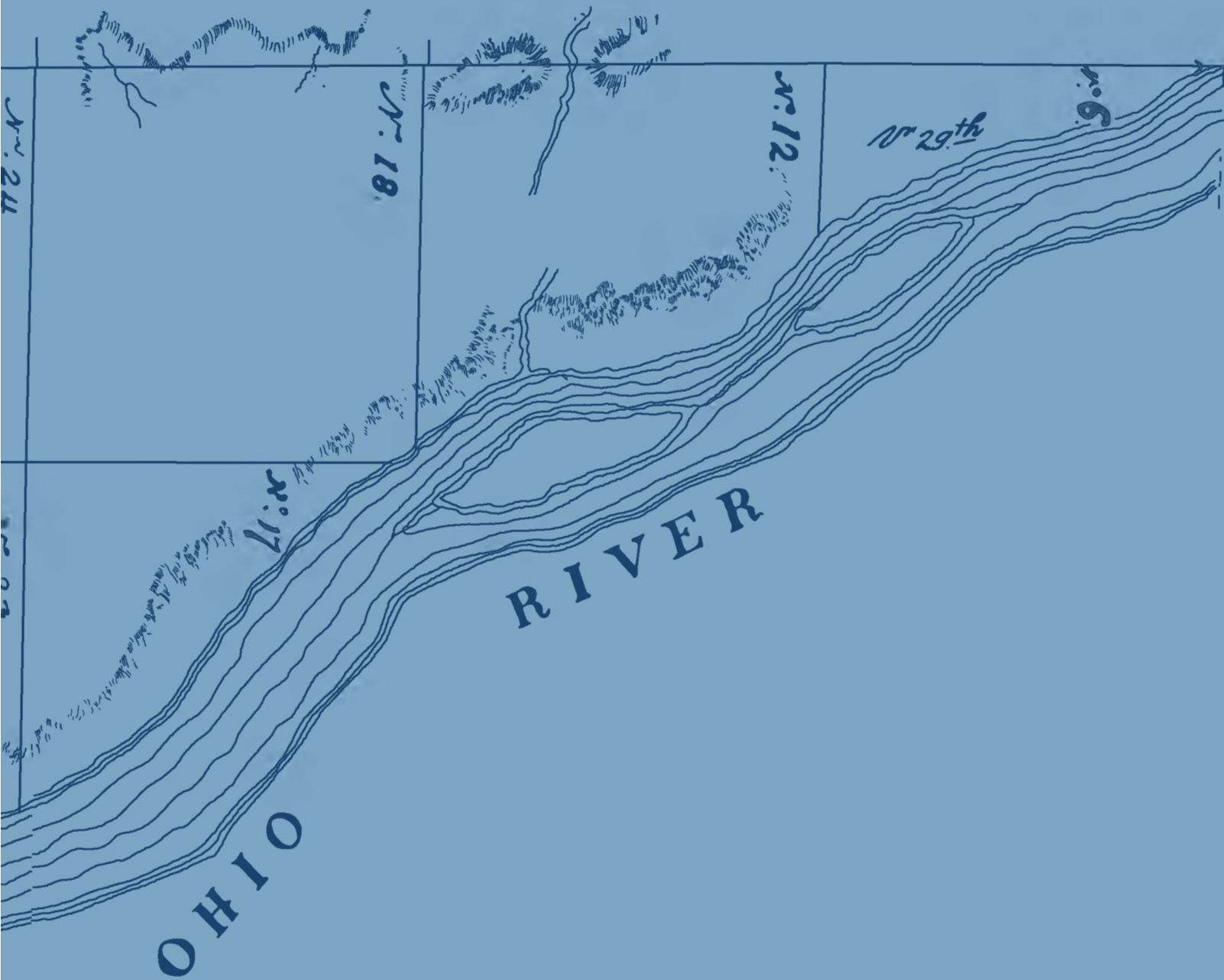
N° 26.



N° 29.

N° 35.





Township No. V. First Range.  
contains 4299 Acres  
Surveyed in 1786 by  
Abalom Martin from New Jersey



---

Inside the front cover is a facsimile of the first plat of a township surveyed under the rectangular system of surveys. The township was surveyed in 1786 by Absalom Martin from New Jersey.

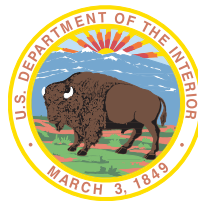
The township was designated Township No. V First Range. Ranges were counted west from the west boundary of Pennsylvania and townships were counted north from the Ohio River. The north boundary of the townships is the Geographer's Line, the first line surveyed in the system, begun on September 30, 1785, under the direction of Thomas Hutchins, Geographer of the United States.

Under the Land Ordinance of May 20, 1785, only the exterior boundaries of townships were actually surveyed. Township plats were marked by subdivisions into sections or "lots" 1 mile square, numbered from 1 to 36, commencing with No. 1 in the southeast corner of the township and running from south to north in each sequence to No. 36 in the northwest corner of the township. In subsequent years, the subdivision lines were surveyed on the ground and are shown on later plats.

---

# **Manual of Surveying Instructions**

## **For the Survey of the Public Lands of the United States**



**Prepared by the  
United States Department of the Interior  
Bureau of Land Management  
Cadastral Survey**

**2009**

## Key to Citation of Authorities, by Volume and Page or Section

A-	Administrative Decisions of the Department of the Interior.
CFR	Code of Federal Regulations of the United States of America.
F.	Federal Reporter. Decisions of the United States Courts of Appeals.
F.2d	Federal Reporter, second series.
F.3d	Federal Reporter, third series.
IBLA	Decisions of the Interior Board of Land Appeals, Department of the Interior, September 1970 and later.
Interior Dec.	Decisions of the Department of the Interior, 1930 and later, beginning with Vol. 53.
M-	Department of the Interior Solicitor's Opinion.
Pub. Lands Dec.	Decisions of the Department of the Interior relating to the public lands through 1929, Vols. 1 to 52.
Rev. Stat.	Revised Statutes of the United States; citation includes section number.
Stat.	United States Statutes at Large.
Title 43	Public Lands: Interior.
U.S.	United States Reports. Decisions of the Supreme Court of the United States.
U.S.C.	United States Code (The Code of the Laws of the United States).

Section numbers cited in this Manual without other designation indicate the chapter and chapter section of the Manual.

---

The information contained within this *Manual of Surveying Instructions* assures consistency with the Cadastral Data Content Standard developed by the Federal Geographic Data Committee's Subcommittee on Cadastral Data in support of the requirements of the Office of Management and Budget Circular No. A-16, revised, entitled *Coordination of Geographic Information and Related Spatial Data Activities*.

---

The Office of Cadastral Survey of the Bureau of Land Management acknowledges with gratitude the generous donation by James A. Simpson of the copyright and some of the associated image production materials for his book *River & Lake Boundaries*, case studies from which appear in Chapters III and VIII of this edition of the *Manual of Surveying Instructions*.

---

*Suggested citation for general reference:*

*U.S. Department of the Interior. 2009. Manual of Surveying Instructions: For the Survey of the Public Lands of the United States. Bureau of Land Management. Denver, CO: Government Printing Office.*

*Suggested citation for technical reference:*

*Manual of Surveying Instructions (2009).*

ISBN 978-0-9791310-2-8  
BLM/WO/GI-09/010+9600

[www.blm.gov](http://www.blm.gov)



**2009 Edition**

United States

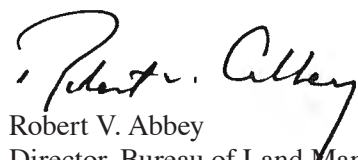
Department of the Interior

Bureau of Land Management

Manual of Surveying Instructions

Prepared and published under the supervision of the Director, Bureau of Land Management.

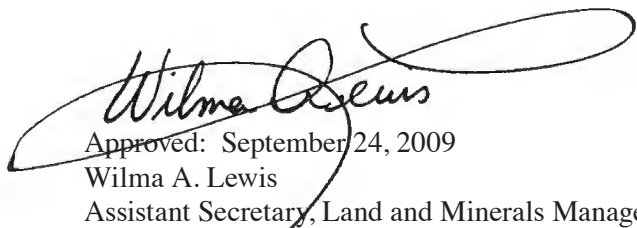
The following instructions, issued for the guidance of all cadastral surveyors executing surveys with special instructions, were prepared under my supervision, and will supersede all previous instructions or directives on the technical subjects contained therein.



Robert V. Abbey

Director, Bureau of Land Management

Under the authority of Title 43 U.S.C. §§ 2 and 1201, and subject to the authority of the Secretary of the Interior, the *Manual of Surveying Instructions* was created subject to my direction and control.



Approved: September 24, 2009

Wilma A. Lewis

Assistant Secretary, Land and Minerals Management

Department of the Interior

Washington, DC



# Contents

---

## Chapter I

<b>The General Plan</b> .....	1
The Manual .....	1
The Federal Lands .....	4
Laws and Rules Relating to Surveys.....	7
Organization .....	14
The Public Land States.....	15
The Non-Public Land States.....	17
Chapter I Notes .....	18

## Chapter II

<b>Methods of Survey</b> .....	27
Introduction .....	27
Measurement .....	27
The Geodesy of Large-Scale Cadastral Surveys.....	28
Coordinate Systems and Projections .....	34

## Chapter III

<b>The System of Rectangular Surveys</b> .....	39
Introduction .....	39
General Scheme.....	39
Initial Points .....	40
Principal Meridian.....	40
Base Line .....	42
Protraction Diagrams Plan of Survey .....	42
Standard Parallels.....	42
Guide Meridians .....	43
Township Extérieurs .....	43
Subdivision of Townships .....	54
Irregular Townships.....	59
Extension and Completion Surveys .....	60
Subdivision of Sections.....	64
Protraction Diagrams.....	76
Developing Amended Protraction Diagrams.....	77

General Rules on Surveying Amended Protraction Diagrams .....	79
Meandering.....	81
Swamp and Overflowed Lands .....	89
Limits of Closure for Original Surveys .....	90
Marking Lines Between Corners.....	91
Summary of Objects to be Noted and Sketches .....	93
Soil Classification .....	96
Chapter III Notes .....	97

## Chapter IV

<b>Monumentation</b> .....	105
Introduction .....	105
Legal Significance of the Monument.....	105
General Requirements .....	105
Corner Monument Material .....	106
Construction of Monuments .....	106
Special-Purpose Monuments .....	107
System of Marking .....	109
Marks on Corner Monuments.....	109
Marks on Special-Purpose Monuments.....	120
Corner Accessories .....	121
Arrangement and Marking of Corner Accessories .....	124

## Chapter V

<b>Principles of Resurveys</b> .....	129
Resurveys.....	129
Jurisdiction .....	131
Bona Fide Rights of Claimants.....	133
General Field Methods .....	134
The Dependent Resurvey.....	135
The Independent Resurvey .....	137
Special Cases .....	143
Resurvey Summary, Including Subdivision of Sections .....	143



**Chapter VI**

**Resurveys and Evidence** ..... 147

    The Nature of Resurveys ..... 147

    Identification of Existent Corners ..... 148

    Identification of Obliterated Corners ..... 149

    Direct Evidence of Existent and  
        Obliterated Corners ..... 150

    Collateral Evidence of Obliterated Corners ..... 154

    Corner Positions Based on the Protection of  
        Bona Fide Rights: 43 U.S.C. 772 ..... 157

    Independent Resurveys: Bona Fide Rights  
        and the Location of Alienated Lands ..... 162

**Chapter VII**

**Resurveys and Restoration** ..... 165

    Restoration of Lost Corners ..... 165

    Primary Methods ..... 166

    Secondary Methods ..... 173

    Special Cases ..... 180

    Summary ..... 180

    Chapter VII Notes ..... 181

**Chapter VIII**

**Resurveys and Water Boundaries** ..... 183

    Introduction ..... 183

    Meanders ..... 183

    Navigability ..... 186

    Source of Law Considerations ..... 193

    Opposite Banks Delimitations ..... 194

    Water Body Movements ..... 197

    Partition Lines ..... 209

    Boundaries in Front of Riparian  
        Acquired or Non-Federal Lands ..... 217

    Islands and Sandbars ..... 218

    Erroneously Omitted Lands ..... 219

    Accretion Prior to Entry ..... 221

    Land Outside Meanders with  
        No Gross Error in Survey ..... 221

    Mineral Lands Survey and  
        Water Boundaries ..... 222

Acquired Lands and Tidal Waters ..... 222

Division of Tidewater Flats ..... 223

Protraction Diagrams ..... 224

Chapter VIII Notes ..... 225

**Chapter IX**

**Special Instructions, Field Notes, and Plats**... 283

    Special Instructions ..... 283

    Field Notes and Plat ..... 285

    Field Notes ..... 285

    Plats ..... 295

**Chapter X**

**Special Surveys and Mineral Surveys** ..... 329

    Special Surveys ..... 329

    Mineral Surveys ..... 350

    Special Cases ..... 373

**Appendix I**

**Specimen Field Notes and Plat—  
Original Survey** ..... 375 and pocket, back cover

**Appendix II**

**Specimen Field Notes and Plat—  
Dependent Resurvey** ..... 411 and pocket, back cover

**Appendix III**

**Specimen Field Notes and Plat—  
Mineral Survey** ..... 451 and pocket, back cover

**Appendix IV**

**Supplemental Plat  
Specimen Plat** ..... 473 and pocket, back cover

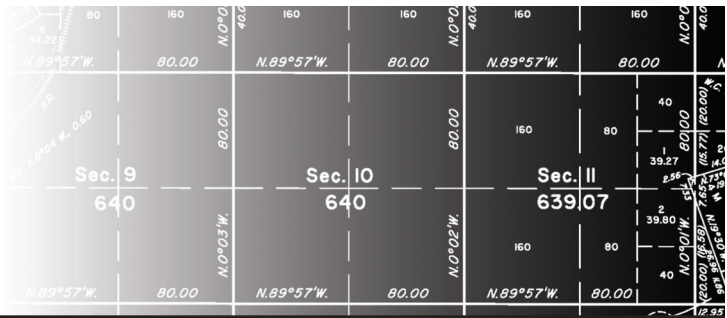
**Appendix V**

**Protraction Diagram  
Specimen Plat** ..... 475 and pocket, back cover

**Index** ..... 477

# Chapter I

# The General Plan



## The Manual

### Introduction

**1-1.** One of the earliest issues faced by the new United States Government after the conclusion of the War of Independence was the appropriate development and disposition of the public lands owned by the Federal Government. The issue was addressed in the United States Constitution itself under Article IV, Section 3, Clause 2, which provides that “The Congress shall have Power to dispose of and make all needful Rules and Regulations respecting the Territory or other Property belonging to the United States” ensuring that the Federal Government, and not the individual States, would determine how the public lands of the United States were to be administered.

Prior to the Constitution’s adoption in 1788 and while the Articles of Confederation (1781) were still in effect, the Congress passed the Land Ordinance of 1785, establishing a system for surveying and thereby demarcating the public lands for their (1) orderly disposition into new States, (2) conveyance from Federal into State and private ownership, or (3) retention for Federal administration. This “rectangular system of survey” typically describes townships of 36 square miles comprised of sections of 1 square mile (640 acres, more or less), each subdivided into quarter sections (160 acres) and quarter-quarter sections (40 acres). Chapter III describes this system in greater detail. Under this land tenure system, each tract of land would receive a unique identifying description. Before a survey was completed, the lands were known as “unsurveyed public lands” and could not be disposed out of Federal ownership.

Since the Land Ordinance of 1785, it has been the continuous policy of the United States that land shall not leave Federal ownership until it has first been surveyed, and an approved plat of survey has been filed. After the survey, persons interested in homesteading or making other authorized land entries under the Federal

public land laws could identify what lands were available for claim and entry. The corner monuments on the ground established actual on-the-ground locations for the boundaries of the lands entered, patented, and/or otherwise conveyed. This process assures the orderly disposition of the public lands and avoids confusion and contention.

Thirty of the fifty current States (“public domain States”) were originally surveyed under this system. With very few exceptions all chains of title to privately owned land in those 30 States trace back to a Federal land patent or other grant. These titles contain a written land description and locatable, on-the-ground monuments established according to an original “cadastral survey,” which *created* (not merely located) identifiable land boundaries. In litigation concerning land boundaries in these 30 States, often it is necessary to determine what specific lands left Federal ownership under a given Federal land patent or other instrument of conveyance and what lands remain in Federal ownership. Reference to the original patent and to its statutory authority, as well as the relevant survey (including the survey monuments, survey notes and plat, and instructions), are often needed for proper adjudication of modern land disputes in these 30 States, regardless of whether any Federal interests are directly involved in the dispute. Land ownership and boundaries in the other 20 States, i.e., the Thirteen Original States plus Hawaii, Kentucky, Maine, Tennessee, Texas, Vermont, and West Virginia, were established by other means and surveyed according to different systems and standards.

**1-2.** This *Manual of Surveying Instructions* (Manual) represents the latest in a series of official and binding survey instructions dating back to 1804; the most recent prior to this edition was issued in 1973. The dominant Federal policy has shifted from one favoring disposal and settling of the unreserved public lands to one favoring retention, administration, and control. This Manual, related Manual supplements and special instructions, and all former editions remain legally relevant because

they provide the instructions in force at the time a given survey was conducted. This edition of the Manual governs the conduct of all surveys and resurveys of the official boundaries of all Federal interest lands authorized or approved by the Bureau of Land Management (BLM) in the Department of the Interior after its issuance.<sup>1</sup> The same is true for prior Federal surveys; they are governed by the edition of the Manual in force at the time they were authorized and performed. Accordingly, the cadastral survey itself governs Federal land conveyances issued thereunder and the lands described in any given private chain of title, some of which are now more than 200 years long. Regardless of its length, each such chain of title begins with a land description established by an original cadastral survey prior to issuance of the patent or other conveyance document.

Every effort has been made in this edition of the Manual to preserve the long-standing principles of cadastral survey from the 1973 edition of the Manual while accommodating updated technology and making clarifications as deemed necessary. Advances in technology may make the surveyor's job more efficient and various relatively minor changes in survey policy and techniques may occur over time, but the job itself and the basic principles have not changed since 1785. Security of legal title to land, one of the bulwarks of our basic freedoms, is the fundamental object of the cadastral surveyor's work and of this Manual.

## Purpose and Scope of the Manual

**1-3.** The *Manual of Surveying Instructions* describes how cadastral surveys are made in conformance with statutory law and its judicial interpretation. This chapter summarizes the various laws governing cadastral surveys, often referred to as official surveys or Federal authority surveys, and the general plan of surveying derived from them. This Manual is not intended to limit the survey authority or practices of any Federal agency other than the BLM.

The Chapter I Notes provide historical background to facilitate present-day understanding of the terms and practices used in prior editions of this Manual. The Chapter I Notes also provide additional history on the legal context of the surveying of Federal interest lands.

---

<sup>1</sup> The term "Federal interest lands," rather than "public lands," is used throughout this edition of the Manual to reflect this change in orientation from disposal to retention and management of its land by the Federal Government, as well as to articulate the extent of BLM's survey authority. Federal interest lands include, but are not limited to, public lands that have never left Federal ownership.

**1-4.** Surveying, in general, is the art and science of measuring and locating points, lines, angles, and elevations on the surface of the earth, including within underground workings, and on the beds of bodies of water.

A cadastral survey creates or reestablishes, marks, and defines boundaries of tracts of land. Cadastral surveys referred to in this Manual are the official surveys of the United States. In the general plan, each cadastral/official survey includes: a request for survey; special instructions; assignment instructions; a field note record of the observations, measurements, and monuments descriptive of the work performed; and a plat representing the official survey. All are subject to review, approval, and/or acceptance of the Director, Bureau of Land Management (Director, BLM). A cadastral survey is not complete until it is officially filed with the BLM as the culmination of this process.

**1-5.** The Manual prescribes the procedures and principles for establishing or reestablishing these boundaries. The instructions contained in this Manual will be observed by surveyors engaged in the execution of official Federal surveys. They are of utmost importance in maintaining a consistent and orderly survey system based upon certainty and predictability in survey procedures. A failure to follow the Manual may be considered an error. Surveys may be canceled and ordered redone if the Manual is not properly followed. The practices and explanations set forth here are also broadly applicable for other surveyors.

A cadastral/official survey is the highest form of boundary evidence available to the Federal Government, providing legal evidence of the geographic limits of the Federal interest in land. A cadastral survey is a formal decision by the Federal Government and is subject to administrative or judicial appeal. Official surveys are executed by authorized surveyors acting in the stead of and under the direction of the Director, subject to the delegated authority of the Secretary of the Interior. Therefore, it is critical that surveyors properly perform their duties; the execution of an official survey impacts the boundaries of all present and future landowners.

An official survey is distinct from a local survey or an administrative survey. A local survey is an opinion on the location of a boundary based on a survey that does not contain every element of an official survey. An administrative survey is a local survey for a Federal agency executed by a Federal employee or an agent of a Federal agency for administrative purposes.



**1-6.** Within the public domain States, boundaries that trace their origin to a Federal instrument of conveyance created when the United States owned both sides of the boundary are governed by applicable Federal laws and surveyed by the procedures and principles in the appropriate editions of this Manual. In all States, boundaries of Federal interest lands that trace their origin to an instrument of conveyance created when the United States did not own both sides of the boundary are governed by applicable Federal or State laws, which may involve survey by the procedures and principles in the appropriate portions and edition(s) of this Manual. Boundaries of non-Federal land in all States created when the United States owned neither side of the boundary are governed by the applicable State or foreign sovereign law in effect at the time of their creation.

Some States have enacted or adopted the Manual, thus making it explicitly applicable to boundaries of non-Federal land within such State. In cases where no Federal interest lands are involved and the State has not enacted or adopted the Manual, the surveying procedure must necessarily be consistent with due process and applicable State law.

### Source of Law

**1-7.** When State law (or foreign sovereign law) and Federal law conflict in application to an identical fact situation, the surveyor must ascertain which law would most likely be found to be controlling and followed by the final court of competent jurisdiction. Final determination as to the controlling law is made by a court.

Surveyors should be guided, however, by the principle that the controlling law of an individual boundary of a parcel will be that law under which that boundary was created. If the boundary in question is a section line, even if no Federal interest land now is affected, Federal law, i.e. the law under which the boundary was created, will generally control its position. If, on the other hand, the boundary in question was created by a county or local surveyor or an individual acting under State law, then the answer to what law controls will depend on whether the State has adopted the Manual or some other standard to guide its survey procedures. By the same token, boundaries created by foreign sovereigns, such as Mexican land grants, will be controlled by application of the relevant law of Mexico at the time the boundary was established.

The surveyor cannot resolve such legal issues, but should be aware of them, use good judgment, and be prepared to provide technical advice.

## Basic Surveying Principles and Practices

**1-8.** Application of basic surveying principles and practices to large-scale areas requires an understanding of the stellar, solar, and satellite methods for making observations to determine the true meridian, the treatment of the convergency of meridians, the running of the true parallels of latitude, the effect of elevation on distances, and the conversion in the direction of lines so that at any point the angular value will be referred to the true meridian at that place. These subjects are therefore explained and examples given with specific relation to the approved surveying practice.

**1-9.** The Manual gives extended treatment to subdivision of sections, restoration of lost or obliterated corners, resurveys, and special surveys of many kinds. These now make up a substantial portion of the surveying program of the BLM. Emphasis is placed on thoroughness in the identification and perpetuation of the surveys already completed.

### Development of the Manual

**1-10.** Since 1785, the surveys of public lands have been conducted under the laws and rules of the Public Land Survey System (PLSS). The first surveys, covering parts of Ohio, were made by surveyors appointed by Congress or the States under the supervision of the Chief Geographer of the United States and complying with the Land Ordinance of May 20, 1785. A beginning point was established where the west boundary of Pennsylvania crosses the north bank of the Ohio River.

Based on early laws, that part of the Northwest Territory that became the State of Ohio was the experimental area for the development of the rectangular system used by the PLSS. Here the plans and methods were tested in a practical way. Notable revisions of the rules were made as the surveys progressed westward until the general plan was complete.

The Act of May 18, 1796, provided for the appointment of a Surveyor General, whose duty was to survey the public lands northwest of the Ohio River and above the mouth of the Kentucky River. A Surveyor General of the Lands of the United States South of the State of Tennessee was appointed in 1803 with the same duties as the first Surveyor General (Act of March 3, 1803 (2 Stat. 229)). Eventually, a Surveyor General was appointed for each new surveying district created in the territories and States as lands were opened for settlement.

The first set of surveying instructions was the actual Federal survey statutes. Initially, advice and general instructions were given to the Surveyors General by the Secretary of the Treasury, who was then in charge of land sales. Beginning in 1812, instructions were issued by the Commissioner of the General Land Office (GLO), an agency within the Treasury Department. Subsequent instructions were given to surveyors in manuscript or in printed circulars.

In 1831, the Commissioner of the General Land Office issued detailed instructions to the Surveyors General concerning surveys and plats. The applicable parts were incorporated by individual Surveyors General in bound volumes of instructions suitable for use in the field by deputy surveyors. From these directions the *Manual of Surveying Instructions* evolved.

The Act of July 4, 1836, placed the overall direction of the public land surveys under the Principal Clerk of the Surveys under the direction by the Commissioner of the General Land Office. The immediate forerunner of the Manual series was printed in 1851 as *Instructions to the Surveyor General of Oregon; Being a Manual for Field Operations*. Its use was soon extended to California, Minnesota, Kansas, Nebraska, and New Mexico. In a slightly revised version, these instructions were issued as the Manual of 1855.

In 1946 the General Land Office was merged with the Federal Grazing Service to form the new Bureau of Land Management, which assumed responsibility for the functions and duties involved in managing the public lands, including the cadastral survey functions and responsibility for the Manual.

**1-11.** Previous editions of the Manual were issued in 1855 (reprinted as the Manual of 1871), 1881, 1890, 1894, 1902, 1930, 1947, and 1973. Instructions modifying specified surveying operations were prescribed in 1864 (and reprinted as the Instructions of 1871). Advance Sheets of the first six chapters of what would become the Manual of 1930 were promulgated in 1919, and a manuscript edition of the chapter on plats was put into effect in 1928. Throughout, and to this day, the primary focus of the Manual has been, and remains, the integrity of the PLSS and the system of Federal survey and land records.

## The Manual Supplements

**1-12.** The following are supplements to this Manual:

- (1) *Restoration of Lost or Obliterated Corners and Subdivision of Sections, a Guide for*

*Surveyors*. The guide provides an introduction to the rectangular system of public land surveying and resurveying, with a compendium of basic laws relating to the system. The restoration and subdivision guide answers many common questions arising in practical work. Although intended especially for county and other local surveyors and others who may have occasion to conduct local or administrative surveys, the guide is also of interest to attorneys, title insurance company personnel, and others who have professional interests in former or present Federal lands in the PLSS.

(2) *Specifications for Descriptions of Tracts of Land for Use in Executive Orders and Proclamations*. The specifications give guidance to persons who write and interpret land descriptions. The specifications' purpose is to assist in producing legal descriptions that are definite, legally defensible, and susceptible to only one interpretation. It provides standardized processes for review of descriptions to assure that only valid descriptions are published.

(3) *Glossary of BLM Surveying and Mapping Terms*. The glossary is an authoritative reference of survey and mapping definitions used both within and outside the BLM.

(4) *Mineral Survey Procedures Guide*. This guide provides an introduction to the mineral lands system of Federal land surveying and resurveying and includes a compendium of basic laws relating to the system. It also answers many common questions encountered in practical survey work. Although intended especially for U.S. Mineral Surveyors, it is also of interest to locators, land surveyors, mineral examiners, attorneys, title insurance company personnel, and others who have professional interests in mineral lands.

## The Federal Lands

### Definitions

**1-13.** "Federal lands" or "Federal interest lands," as used in this Manual, refer to any lands in which the United States holds title, an estate, or other interest. Federal lands or Federal interest lands include, but are not limited to: public domain lands, or those lands that were acquired by the United States from another sovereign and have

never left Federal ownership (public domain lands were classified into, among others, agricultural lands, mineral lands, and Indian lands; for administrative purposes, these lands may now be administered by any one of several Federal agencies), private land claims (which were never part of the public domain), and acquired lands (which may or may not have ever been part of the public domain and which may be administered by any one of several Federal agencies). While the primary focus of the Manual is the PLSS States, Federal interest lands can be located anywhere. However, outside of the PLSS States, some portions of the Manual may not be applicable, as a technical matter. For treatment of mineral lands surveys, see sections 10-77 through 10-230.

The original public domain is comprised of the lands that have been added to the area included in the Thirteen Original States. These lands included the lands that were turned over to the Federal Government by the Colonial States and the areas acquired later from the Native Americans or foreign powers. In other words, the public domain includes the States west of the 18 Eastern States created from Colonial lands, excluding Hawaii and Texas (figure 1-1).

## Administration

**1-14.** After admission of the public domain States into the Union, the Federal Government continued and continues to hold title to and administer unappropriated lands. Various enabling acts expressly provide that the title to unappropriated lands within these States shall be retained by the United States. Moreover, lands in the territories not appropriated under competent authority before they were acquired are the exclusive property of the United States. The lands are to be administered or prepared for disposal to such persons at such time, in such modes, and by such titles as the Government may deem most advantageous to the public. Congress alone has plenary power, derived from Article IV, Section 3, Clause 2, of the Constitution to dispose of and make all needful rules and regulations respecting the territory or other property belonging to the United States.

**1-15.** The Director of the Bureau of Land Management has the authority to determine what lands are Federal interest lands, what lands have been surveyed, what are to be surveyed, what have been disposed of, what remains to be disposed of, and what are reserved. By a well-settled principle of law, the United States, through the Department of the Interior, has the authority and duty to extend the surveys as may be necessary to include lands erroneously omitted from earlier surveys.

Proper administration of Federal interest land requires identifying and marking ownership boundaries or special use boundaries in a manner that defines the physical limits of interests or permitted uses. The BLM, unique among Federal agencies, has been given, in addition to its specific authority to conduct official/cadastral surveys of the public lands, specific authority to survey Federal interest lands in general. Therefore, other Federal entities, as well as federally recognized Indian tribes and their individual members, Alaska Native Corporations, Alaska Natives, and non-Federal landowners, may request assistance from the BLM for official surveys and related cadastral services necessary to meet administrative responsibilities or legal requirements. Funding for official survey services is appropriated directly to the BLM by Congress or, in appropriate cases, is provided by the requester through contributed funds.

## Navigable Waters

**1-16.** Sovereignty over the lands beneath navigable waters<sup>2</sup> lies with the individual States upon statehood, unless explicitly declared otherwise by competent authority. Beds of navigable bodies of water are not public domain lands and are not subject to survey and disposal by the United States.

Under the laws of the United States, the navigable waters have always been and shall forever remain common highways. This includes all tidewater streams and other important permanent bodies of water whose natural and normal condition at the date of the admission of a State into the Union was such as to classify it as navigable water. Tidelands (lands below the line of mean high tide) are not subject to survey as public domain land, save in exceptional instances.

---

<sup>2</sup> "Lands beneath navigable waters" means:

- (1) all lands within the boundaries of each of the respective States, which are covered by nontidal waters that were navigable under the laws of the United States at the time such State became a member of the Union, or acquired sovereignty over such lands and waters thereafter, up to the ordinary high water mark as heretofore or hereafter modified by accretion, erosion, and reliction;
- (2) all lands permanently or periodically covered by tidal waters up to but not above the line of mean high tide and seaward to a line 3 geographical miles distant from the coast line of each such State, and to the boundary line of each such State where in any case such boundary as it existed at the time such State became a member of the Union, or as heretofore approved by Congress, extends seaward (or into the Gulf of Mexico) beyond 3 geographical miles; and
- (3) all filled in, made, or reclaimed lands that formerly were lands beneath navigable waters, as hereinabove defined (67 Stat. 29; 43 U.S.C. 1301(a)(1), (2), and (3)).



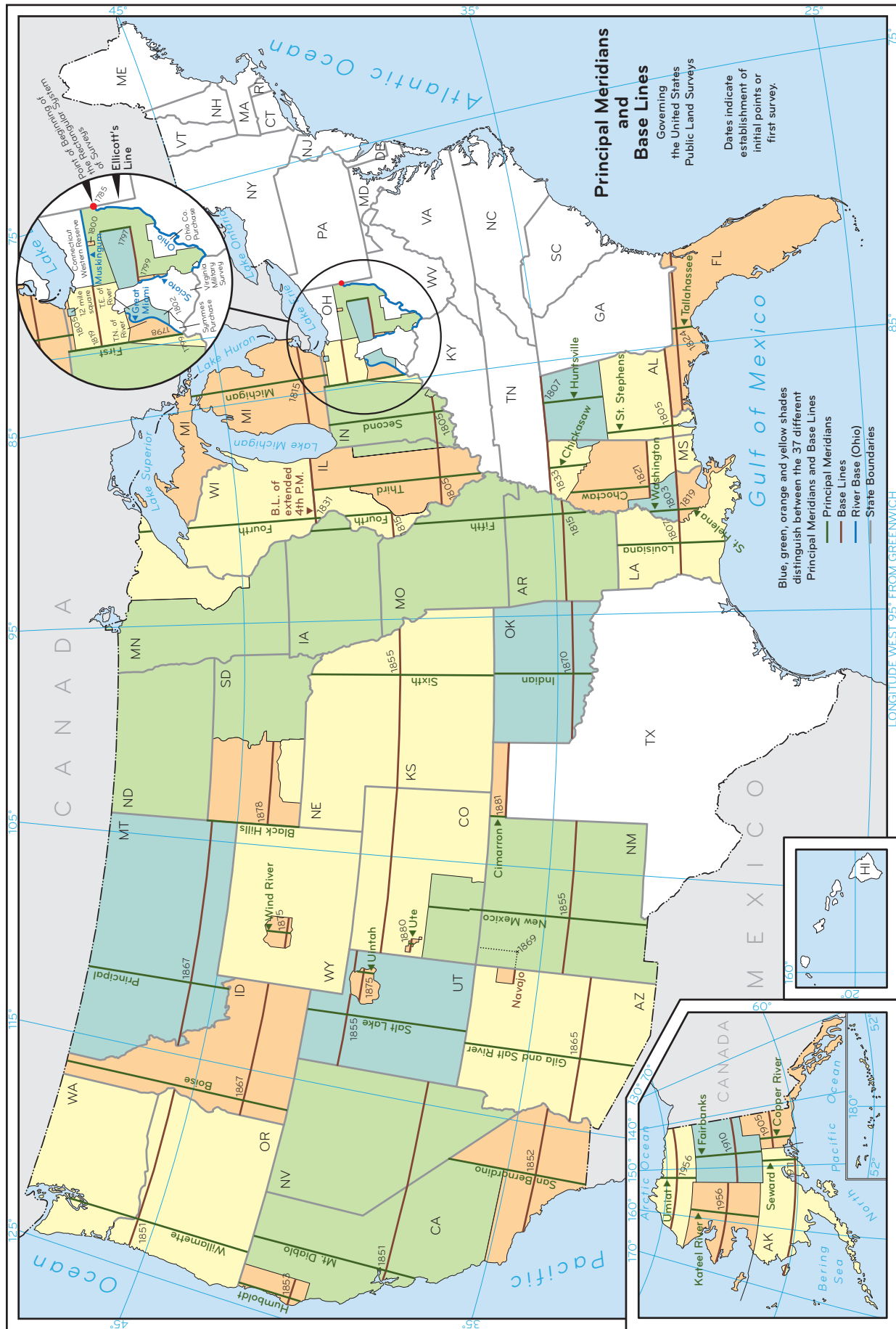


Figure 1-1. The principal meridians and base lines of the Public Land Survey System.

## Swamp and Overflowed Lands

**1-17.** In Alabama, California, Florida, Illinois, Indiana, Iowa, Louisiana, Michigan, Minnesota, Mississippi, Ohio, Oregon, and Wisconsin, the swamp and overflowed lands, though public domain, passed to the States. This was done upon identification as such by public land survey and approved selection, the title then being subject to disposal by the States.

The Act of March 2, 1849 (9 Stat. 352), granted to the State of Louisiana all its swamp and overflowed lands for the purpose of aiding in their reclamation. The Act of September 28, 1850 (9 Stat. 519), extended the grant to other public land States then in the Union. The grant was also extended to Minnesota and Oregon by the Act of March 12, 1860 (12 Stat. 3). These various grants were carried over into 43 U.S.C. 982 (Rev. Stat. 2479). Section 4 of the Act of July 23, 1866 (Rev. Stat. 2488; 14 Stat. 218), established the rules and methods for the identification of the granted lands in California. A notable exception to the swamp land laws is found in the Arkansas Compromise Act of April 29, 1898 (30 Stat. 367; 43 U.S.C. 991), by which all right, title, and interest to the remaining unappropriated swamp and overflowed lands reverted to the United States.

The provisions of the grants described above apply to elevations below the uplands where, without the construction of levees or drainage canals, the areas would be unfit for agriculture. The grants apply to all swamp and overflowed lands unappropriated at the dates of the granting acts, whose character at that time would bring them within the provisions of the grant. It is important that original survey plats and field notes within these States identify the extent of swamp and overflowed lands. Discussion of swamp and overflowed lands in connection with field examinations and surveys is found in sections 3-208 through 3-214.

## Laws and Rules Relating to Surveys

### Surveying and Survey Administration Laws

**1-18.** In recognition of the fundamental principle of the common law that a valid land conveyance shall, in addition to other requirements, contain a description sufficiently accurate to identify boundaries with a required degree of certainty, Congress has passed a number of laws governing the manner in which Federal interest lands are to be surveyed and how the survey process will be administered.

The PLSS provides a uniform system of keeping records related to conveyance documents. The Land Ordinance of May 20, 1785 adopted the PLSS as “An ordinance for ascertaining the mode of locating and disposing of lands in the western territory, and for other purposes therein mentioned.”

Based upon field surveys establishing on-the-ground monuments prior to conveyance, the PLSS marked an important transition from the surveying practice that generally prevailed in the Colonial States where lands were described by irregular metes-and-bounds, with each parcel depending more or less on the description of its neighbors.

This Manual serves as the official interpretation of the controlling survey law and doctrines by the Department of the Interior with respect to the PLSS. It is applicable to a greater or lesser degree to official surveys of Federal interest lands outside public domain States as well. It also provides additional technical details to make the land tenure system function effectively. This Manual is not intended to limit the survey authority or practices of any Federal agency other than the BLM.

**1-19.** The rectangular surveying system of the PLSS was established by law and was devised with the objective of marking upon the ground and fixing for all time legal subdivisions for purposes of description and disposal of the public domain under the general land laws of the United States. The system is used for the purpose of describing and managing Federal interest lands in public domain States.

**1-20.** The following are selected Acts pertinent to surveying and survey administration:

The Act of May 18, 1796 (1 Stat. 464; 43 U.S.C. 52, 751, and 931), made explicit the requirement, still in effect, that lands were to be surveyed and returned prior to conveyance. This act also began the contract system of surveying the public lands, which endured until 1910 when the direct system was enacted.

The status of navigable waters was also established at this time: “All navigable rivers, within the territory occupied by the public lands, shall remain and be deemed public highways; and, in all cases where the opposite banks of any streams not navigable belong to different persons, the stream and the bed

thereof shall become common to both” (Rev. Stat. 2476; 43 U.S.C. 931).<sup>3</sup>

The Act of May 10, 1800 (2 Stat. 73; 43 U.S.C. 751), established that the Surveyor General would prepare three plats for each survey. It directs the division of townships into sections of 640 acres each and half sections of 320 acres each, as nearly as may be. This is to be done by running parallel lines from east to west and from south to north at the distance of 1 mile from each other, marking the corners at the distance of each half mile on the lines running east to west and at the distance of each mile on those running from south to north, and placing the excess or deficiency of measurement in the legal subdivision adjoining the north or west exterior of the township.

Of the three plats prepared by the Surveyor General, the original was retained by the Surveyor General, the duplicate was sent to the Department of Treasury and the triplicate was used at the local land office. Pursuant to this Act, land started to be sold in units of 160 acres or more.

The three-plat system has been modified at various times. Today the BLM’s State Office Chief Cadastral Surveyor prepares two official plats. Depending on the State in which the land is located, the Chief retains the original or sends it to the designated State Official, and sends the duplicate, called the Secretary’s copy, to the BLM Chief Cadastral Surveyor in Washington, DC. The latter is currently held at the BLM Eastern States Office.

The Act of February 11, 1805 (2 Stat. 313; 43 U.S.C. 752), directs that the public lands be subdivided into quarter sections (by protraction not by survey). This act further provides that boundary lines that have not been actually run and marked as aforesaid shall be ascertained by running straight lines from the established corners to the opposite corresponding corners (statutory method of subdivision except for fractional townships and sections described below, see Acts of April 24, 1820, and April 5, 1832). In those portions of the townships where

no such opposite or corresponding corners have been or can be fixed, the said boundary lines shall be ascertained by running from the established corners due north and south or east and west lines, as the case may be, to the external boundary of such fractional unit (statutory method of subdivision of fractional townships and sections; see Acts of April 24, 1820 and April 5, 1832).

The most important parts of the Act of February 11, 1805, are:

- (1) All section lines shall be surveyed and all quarter corners on those lines established.
- (2) The corners set by the Surveyor General are unchangeable.
- (3) The lines marked by the Surveyor General are unchangeable.
- (4) The lengths of the section lines are unchangeable.
- (5) The quantity or area of a section or fractional section is unchangeable. However, case law in the courts later established that the Surveyor General, i.e., the Government, could correct or change a survey up until such time as private rights were acquired based on the survey.

The Act of April 25, 1812 (2 Stat. 716; 43 U.S.C. 2, 6, 12, 14, and 17), created the GLO as a bureau within the Department of the Treasury. These responsibilities are carried out today by the BLM Director. The Act states the Secretary of the Interior, or such officer as the Secretary may designate [the BLM Director], “shall perform all executive duties appertaining to the surveying and sale of the public lands<sup>4</sup> of the United States,

<sup>3</sup> This section has been interpreted to mean that the common law rules of riparian ownership should apply—that instead of the owners of opposite banks of a nonnavigable stream being tenants in common of the bed, each held in severalty to the center of the stream.

<sup>4</sup> “Public Lands” as referenced in 43 U.S.C. 2 is different from the “public lands” as defined in the Federal Land Policy and Management Act of 1976, as amended, 43 U.S.C. 1701 et seq. The “public lands” referenced in 43 U.S.C. 2 include land owned by the United States that was part of the original public domain, not just those lands now managed by the BLM. The General Land Office (subsequently the BLM, as successor agency to the GLO) surveyed the public domain lands before they left Federal ownership—in fact, in order that they could leave Federal ownership. These surveys were carried out according to instructions issued by the Secretary of the Interior acting through the GLO (or BLM)—instructions that were precursors to, and incorporated into each successive edition of the Manual.

or in anywise respecting such public lands, and, also, such as relate to private claims of land, and the issuing of patents for all grants of land under the authority of the Government” (Rev. Stat. 453; 43 U.S.C. 2).

The Acts of April 24, 1820 (3 Stat. 566; 43 U.S.C. 753), and April 5, 1832 (4 Stat. 503; 43 U.S.C. 753), direct that the corners and contents of half-quarter and quarter-quarter sections and fractional sections shall be ascertained, as nearly as possible, in the manner and on the principles directed and prescribed in the Act of February 11, 1805.

The Act of March 3, 1849 (9 Stat. 395; 43 U.S.C. 1451 and 1457), creates the Department of the Interior. This act transferred the GLO to the new Department and authorized the Secretary of the Interior to perform all the duties of the GLO, formerly discharged by the Secretary of the Treasury.<sup>5</sup>

The Acts of March 3, 1853, and July 9, 1870 (10 Stat. 245; 16 Stat. 218; Rev. Stat. 2406; 43 U.S.C. 766), provide that the “public surveys shall extend over all mineral lands; and all subdividing of surveyed lands into lots less than one hundred and sixty acres may be done by county and local surveyors at the expense of claimants; but nothing in this section contained shall require the survey of waste or useless lands.” See sections 10-94 through 10-230 for additional details regarding the administration and surveys of mineral lands.

The Act of April 8, 1864 (13 Stat. 41; Rev. Stat. 2115; 25 U.S.C. 176), provides that whenever it becomes necessary to survey any Indian or other reservations, or any lands, the same shall be surveyed under the direction and control of the BLM and as nearly as may be in conformity to the rules and regulations under which other public lands are surveyed.

The Act of March 3, 1899 (30 Stat. 1098; 43 U.S.C. 751a), extended the PLSS to Alaska.

The Act of March 3, 1909 (35 Stat. 845), as amended (36 Stat. 884; 90 Stat. 2743, 2792; 43 U.S.C. 772), provides that: “The Secretary of the Interior may, as of March 3, 1909, in his discretion, cause to be made, as he may deem wise under the rectangular system on that date provided by law, such resurveys or retracements of the surveys of public lands as, after full investigation, he may deem essential to properly mark the boundaries of the public lands remaining undisposed of: Provided, that no such resurvey or retracement shall be so executed as to impair the bona fide rights or claims of any claimant, entryman, or owner of lands affected by such resurvey or retracement” (43 CFR 9180.0).

This General Resurvey Act is the authority for the BLM to execute resurveys of Federal interest lands provided bona fide rights or claims as to location are not impaired.

The law provides a penalty for the unauthorized alteration or removal of any Government survey monument or marked trees: “Whoever willfully destroys, defaces, changes, or removes to another place any section corner, quarter-section corner, or meander post, on any Government line of survey, or willfully cuts down any witness tree or any tree blazed to mark the line of a Government survey, or willfully defaces, changes, or removes any monument or bench mark of any Government survey, shall be fined under this title or imprisoned not more than six months, or both” (108 Stat. 1796, 2146; 18 U.S.C. 1858). The willful destruction of monuments and corners of an official mineral survey is within the purview of this statute.

The Act of June 25, 1910 (36 Stat. 703, 741), provides, under “Surveying the Public Lands”: “The surveys and resurveys to be made by such competent surveyors as the Secretary of the Interior may select . . .” This provision of law brought to a close the practice of letting contracts for the making of surveys of public lands. The surveys are now made under the direct system, by appointed surveyors employed by the Federal Government. Beginning with the Act of May 18, 1796, most public land surveys were made by county and other local surveyors, sworn in as U.S. Deputy Surveyors, under contract with Surveyors General. Today most official surveys

<sup>5</sup> The Secretary of the Interior, or such officer as he or she may designate, is authorized to enforce and carry into execution, by appropriate regulations, every part of the provisions of this title not otherwise specially provided for. The title referenced is Title 43, Public Lands, United States Code; Rev. Stat. 2478; 43 U.S.C. 1201.



are conducted under the direct system, including interagency agreement, and modified contract system of noninherently governmental activities operating under special and assignment instructions.

The Act of September 21, 1918 (40 Stat. 965; 43 U.S.C. 773), provides authority for the resurvey, by the Government, of all privately owned lands of townships in which the disposals exceed 50 percent of the total area. Such resurveys shall be undertaken only upon application of the owners of at least three-fourths of the privately owned land in the township and upon deposit of the estimated costs of the resurvey. Similar resurveys may be made on the application of any court of competent jurisdiction.

On July 16, 1946, the Bureau of Land Management was established within the Department of the Interior in accordance with the President's Reorganization Plan No. 3 of 1946. Under that plan, the General Land Office was abolished and its functions transferred to the Secretary of the Interior (60 Stat. 1097, 1100; 5 U.S.C. App. 519; 43 U.S.C. 1 note; 43 U.S.C. 1201; 43 U.S.C. 1451 note).

The Secretary of the Interior provided, subject to his or her direction and control, that the functions and powers of the General Land Office, and the United States Supervisor of Surveys, together with the field surveying service, be exercised by the Director of the BLM. This includes the cadastral survey functions (President's Reorganization Plan No. 3 of 1950; 64 Stat. 1262 as amended; 5 U.S.C. Appendix; 5 U.S.C. 903 provisions; 43 U.S.C. 1451 provisions; and Departmental Manual—Delegation of Authority).

The Department of the Interior is responsible for the operation, maintenance, and modernization of the PLSS and other spatial databases covering Federal land titles and resources. The Department is also tasked with identifying and marking, by official survey, the boundaries of Federal interest in lands, except when Congress has explicitly assigned a surveying responsibility to another department, bureau, agency, or office.

The Federal Land Policy and Management Act (FLPMA) of October 21, 1976 (90 Stat.

2743, 2766; 43 U.S.C. 1737(c)), provides that the Secretary of the Interior may accept contributions for cadastral surveying performed on Federally controlled or intermingled lands. This is a specific statutory provision to permit the acceptance of private and public contributions for official surveys of (1) lands or interests in lands owned by the United States and (2) lands or interests in lands owned by the United States with an interdependent corner or line with lands not owned by the United States. This substantially reenacts section 103 of the Public Land Administration Act of July 14, 1960 (43 U.S.C. 1364, repealed).

The Act of October 5, 1992 (106 Stat. 1378; 43 U.S.C. 1731 note), provides that appropriations therein made to the BLM, in fiscal year 1993 and thereafter, may be expended for surveys of Federal lands and on a reimbursable basis for surveys of Federal lands.

Other statutes relevant to BLM survey authority in other specific situations or locations are contained in the Chapter I Notes.

## Orders, Regulations, and Policies

**1-21.** Descriptions of tracts of land in Executive orders and proclamations will conform, as far as practicable, to the most recent edition of the *Specifications for Descriptions of Tracts of Land for Use in Executive Orders and Proclamations*, prepared by the BLM (Executive Order 11030, as amended; 1 CFR 19.1)

In the Department of the Interior, the Solicitor has authority to issue final legal interpretations, in the form of M-Opinions published in the *Decisions of the United States Department of the Interior* (Interior Dec.), on all matters within the jurisdiction of the Department, which will be binding, when signed, on all other Departmental offices and officials.

Further, the Office of Hearings and Appeals (OHA) is an authorized representative of the Secretary for the purpose of hearing, considering, and determining matters within the jurisdiction of the Department involving review functions of the Secretary. The Interior Board of Land Appeals (IBLA) is the administrative body that, on behalf of the Secretary, hears appeals of decisions rendered by Departmental officials relating to the use and disposition of public lands and their resources, including land selections arising under the Alaska

Native Claims Settlement Act, as amended (43 CFR 4.1; 43 U.S.C. 1201). Any party who is adversely affected by an official survey has the right to appeal to the Board (43 CFR 4.410). Decisions by the IBLA are binding for the official survey appealed and serve as precedent for future surveys.

**1-22.** Executive Order 12906 (April 11, 1994), as amended, states in part that: “Geographic Information is critical to promote economic development, improve our stewardship of natural resources, and protect the environment.” This Executive order defines National Spatial Data Infrastructure (NSDI) and spatial data and orders agencies to develop, in cooperation with State, local, tribal governments, and the private sector, a coordinated NSDI. The NSDI encompasses the technology, policies, standards, human resources, and related activities necessary to acquire, process, distribute, use, maintain, and preserve spatial data. Cadastral survey data is a geospatial data theme that defines rights and interests in land that affect the value and use of land and comprises an essential element of the NSDI.

**1-23.** Organizationally, the Department of the Interior’s Departmental Manual Part 109, chapter 7 (May 21, 1984), provides that the Assistant Secretary—Land and Minerals Management will exercise Secretarial direction and supervision over the BLM. The Director, BLM, is authorized, except as provided, to exercise the program authority of the Assistant Secretary—Land and Minerals Management with respect to the management of the public domain and acquired lands, including all associated and related functions per Departmental Manual Part 235, chapter 1 (June 28, 2001).

Further, Departmental Manual Part 757 (November 29, 1988) provides, consistent with Office of Management and Budget Circular No. A-16 “Coordination of Geographic Information and Related Spatial Data Activities” (2002), that the Cadastral Survey Program will (1) establish procedures and responsibilities for cadastral surveying activities; (2) coordinate Federal cadastral surveying activities through the Interagency Cadastral Coordination Council (ICCC) and prescribe policy, responsibility, and procedures for cadastral surveys performed by the bureaus and offices of the Department; (3) be responsible for the Public Land Survey System and exercise its authority to survey and resurvey Federal interest lands, including trust territories and Indian land, and land in private ownership; (4) prepare the *Manual of Surveying Instructions* and its amendments and supplements for the Department; (5) maintain the storage and dissemination of survey

data within the Federal survey records system; (6) establish a Geographic Coordinate Data Base of all corner positions related to the PLSS and Federal interest lands, thereby providing the administration and coordination of the establishment and maintenance of the system for the storage and dissemination of survey and land status data for use by local and national realty, land title, and mapping interests; (7) be responsible for the segregation by survey of valid private rights acquired pursuant to a variety of public land laws including the general mining laws; (8) coordinate bureaus’ and offices’ actions that serve to change the official Federal survey records; (9) provide special instructions to the Bureau of Reclamation when the latter exercises its specific authority to conduct cadastral surveys on certain public lands withdrawn for reclamation; (10) execute cadastral surveys for the Bureau of Indian Affairs on Indian reservations; (11) after authorizing other agencies and offices to perform surveys, provide necessary instructions, guidance, and official approval of the records; (12) conduct original surveys; and (13) conduct resurveys for agencies on a reimbursement basis.

**1-24.** In addition, under OMB Circular No. A-16, the BLM is the lead Federal agency with responsibilities for three NSDI spatial data themes: Cadastral, Federal Land Ownership Status, and Public Land Conveyance (patent) Records.

The Circular also establishes the Federal Geographic Data Committee (FGDC) as the interagency coordinating committee for all NSDI-related activities. The FGDC created a Subcommittee for Cadastral Data for interagency cadastral matters. The Subcommittee issued the following Cadastral Data Content Standard for the NSDI:

To provide a standard for the definition and structure for cadastral data which will facilitate data sharing at all levels of government and the private sector and will protect and enhance the investments in cadastral data at all levels of government and the private sector (ver. 1.4, p.2; May 2008).

**1-25.** In summary, the Secretary of the Interior has delegated survey authority and responsibility via the Assistant Secretary—Land and Minerals Management, and the Director, Bureau of Land Management, to the Washington Office Chief Cadastral Surveyor to act as consultant to the Director in the formulation of policies, programs, standards, and procedures of cadastral surveys, to perform all functions and sign all documents

relating to the appointment of U.S. Mineral Surveyors, and to provide the final interpretation of the Manual. The State Office Chief Cadastral Surveyors perform technical supervision and approval of surveys within their jurisdiction.

**Rules of PLSS Survey**

**1-26.** The rules for the PLSS were developed under the early survey statutes and are summarized as follows:

First. The public lands shall be divided by north and south lines run according to the true meridian, and by others crossing them at right angles, so as to form townships of 6 miles square, unless where the line of an Indian reservation, or of tracts of land heretofore surveyed or patented, or the course of navigable rivers, may render this impracticable; and in that case this rule will be departed from no further than such particular circumstances require (figure 1-2).

Second. The corners of the townships shall be marked with progressive numbers from the beginning; each distance of a mile between such corners shall be also distinctly marked with marks different from those of the corners.

Third. The township shall be subdivided into sections, containing, as nearly as may be, 640 acres each, by running parallel lines through the same from east to west and from south to north at the distance of 1 mile from each other,

*Township Line*

6	5	4	3	2	1
7	8	9	10	11	12
18	17	16	15	14	13
19	20	21	22	23	24
30	29	28	27	26	25
31	32	33	34	35	36

*Range Line*

**Figure 1-2.** A regular township.

and marking corners at the distance of each half mile. The sections shall be numbered, respectively beginning with the number 1 in the northeast section and proceeding west and east alternately through the township with progressive numbers, until the 36 be completed.

Fourth. The cadastral surveyors, respectively, shall cause to be marked on a tree near each corner established in the manner described, and within the section, the number of such section, and over it the number of the township within which such section may be; and the surveyors shall carefully note, in their respective field tablets, the names of the corner trees marked and the numbers so made.

Fifth. Where the exterior lines of the townships which may be subdivided into sections or half-sections exceed, or do not extend 6 miles, the excess or deficiency shall be specially noted, and added to or deducted from the western and northern ranges of sections or half-sections in such township, according as the error may be in running the lines from east to west, or from south to north; the sections and half-sections bounded on the northern and western lines of such townships shall be sold as containing only the quantity expressed in the returns and plats respectively, and all others as containing the complete legal quantity.

Sixth. All lines shall be plainly marked upon trees, and measured with chains, containing two perches of 16½ feet each, subdivided into 25 equal links; and the chain shall be adjusted to a standard to be kept for that purpose.<sup>6</sup>

Seventh. Every surveyor shall note in his field tablet the true situations of all mines, salt licks, salt springs, and mill seats which come to his knowledge; all watercourses over which the line he runs may pass; and also the quality of the lands.

Eighth. These field tablets shall be returned to the Secretary of the Interior or such officer as he or she may designate, who shall cause

<sup>6</sup> The superior results obtained by the use of modern linear distance measuring tools and indirect measuring tools, in contrast with the obsolete link chain, have led to the abandonment of the latter, except that the "chain unit," which is peculiarly adapted to public lands surveying, has continued in use. The responsible Chief Cadastral Surveyor can in the special instructions authorize returns in units other than the chain unit.

therefrom a description of the whole lands surveyed to be made out and transmitted to the officers who may superintend the sales. A fair plat shall be made of the townships and fractional parts of townships contained in the lands, describing the subdivisions thereof, and the marks of the corners. This plat shall be recorded in books to be kept for that purpose; and a copy thereof shall be kept open at the office of the Secretary of the Interior or of such agency as he may designate for public information, and other copies shall be sent to the places of the sale, and to the Bureau of Land Management (Rev. Stat. 2395; Parts 135, 235 and 757 Departmental Manual; OMB Circular A-16; 43 U.S.C. 751).

**1-27.** The boundaries and contents of the several sections, half-sections, and quarter-sections of the public lands shall be ascertained in conformity with the following principles:

First. All the corners marked in the surveys, returned by the Secretary of the Interior or such agency as he may designate, shall be established as the proper corners of sections, or subdivisions of sections, which they were intended to designate; and the corners of half- and quarter-sections, not marked on the surveys, shall be placed as nearly as possible equidistant from two corners which stand on the same line.

Second. The boundary lines, actually run and marked on-the-ground and described in the surveys returned by the Secretary of the Interior or such agency as he may designate, shall be established as the proper boundary lines of the sections, or subdivision, for which they were intended, and the length of such lines as returned, shall be held and considered as the true length thereof. And the boundary lines which have not been actually run and marked shall be ascertained, by running straight lines from the established corners to the opposite corresponding corners; but in those portions of the fractional townships where no such opposite corresponding corners have been or can be fixed, the boundary lines shall be ascertained by running from the established corners due north and south or east and west lines, as the case may be, to the watercourse, Indian boundary line, or other external boundary of such fractional township.

Third. Each section or subdivision of section, the contents whereof have been returned by the Secretary of the Interior or such agency as he may designate, shall be held and considered as containing the exact quantity expressed in such return; and the half-sections and quarter-sections, the contents whereof shall not have been thus returned, shall be held and considered as containing the one-half or the one-fourth part, respectively, of the returned contents of the section of which they may make part (Rev. Stat. 2396; Parts 235 and 757 Departmental Manual; OMB Circular A-16; 43 U.S.C. 752).

**1-28.** In every case of the division of a quarter-section, the line for the division thereof shall run north and south, and the corners and contents of half-quarter sections, which may thereafter be sold, shall be ascertained in the manner and on the principles directed and prescribed by the section preceding (43 U.S.C. 752). Fractional sections containing 160 acres or upwards shall in like manner, as nearly as practicable, be subdivided into half-quarter sections, under such rules and regulations as may be prescribed by the Secretary of the Interior, and in every case of a division of a half-quarter section, the line for the division thereof shall run east and west, and the corners and contents of quarter-quarter sections, which may thereafter be sold, shall be ascertained, as nearly as may be, in the manner and on the principles directed and prescribed by the section preceding (43 U.S.C. 752). Fractional sections containing fewer or more than 160 acres shall in like manner, as nearly as may be practicable, be subdivided into quarter-quarter sections, under such rules and regulations as may be prescribed by the Secretary of the Interior (Rev. Stat. 2397; Parts 235 and 757 Departmental Manual; OMB Circular A-16; 43 U.S.C. 753).

## General Rules

**1-29.** From the foregoing synopsis it is evident:

First. That the boundaries and subdivision of the public lands as surveyed under approved instructions by the duly appointed surveyors, the physical evidence of which survey consists of monuments established upon the ground, and the record evidence of which consists of field notes and plats duly approved by the authorities constituted by law, are unchangeable after the passing of title by the United States.



Second. That the original township, section, quarter-section, and other monuments as physically evidenced shall stand as the true corners of the subdivisions which they were intended to represent, and shall be given controlling preference over the recorded directions and lengths of lines.

Third. That sixteenth-section corners not marked in the process of the original survey shall be placed as nearly as possible on the line connecting the section and quarter-section corners, and midway between them, except on the last half mile of section lines closing on the north and west boundaries of the township, or on other lines between fractional or irregular sections.

Fourth. That the center lines of a regular section are to be ascertained by running straight lines from the quarter-section corner on one boundary of the section to the corresponding corner on the opposite section line.

Fifth. That in a fractional section where no opposite corresponding quarter-section corner has been or can be fixed, the center line of such section shall be run from the proper quarter-section corner as nearly in a cardinal direction to the meander line, reservation, or other boundary of such fractional section, as due parallelism with section lines will permit.

Sixth. That lost or obliterated corners of the approved surveys must be restored to their original locations whenever this is possible.

**1-30.** The basic provisions require that the public lands “shall be divided by north and south lines run according to the true meridian, and by others crossing them at right angles, so as to form townships six miles square;” that “the townships shall be subdivided into sections, containing as nearly as may be, six hundred and forty acres each;” and that “the excess or deficiency shall be specially noted, and added to or deducted from the western and northern ranges of sections or half-sections in such townships, according as the error may be in running the lines from east to west, or from south to north.” The system of rectangular surveys fits the basic requirements to the curved surface of the earth.

In this rectangular plan, the township boundaries are intended to be due north and south or due east and west.

The boundaries running north and south are termed “range lines.” The boundaries running east and west are termed “township lines.” In this general plan, all the lines are rhumb lines and cross each meridian at a constant angle.

The range lines are great circles of the earth that, if extended, would converge and intersect at the North Pole. This convergency becomes apparent in the measurement of the township lines. The convergency is taken up at intervals by the running of standard parallels, on which the measurements are again made full. On the standard parallels, first termed “correction lines,” there are offsets in the range lines and two sets of corners, standard corners for the lines to the north and closing corners for lines to the south. The usual interval between the standard parallels is 24 miles, but there were many exceptions in the older surveys.

To make the sections represent “square miles” as nearly as may be, the meridional lines are run from south to north and parallel to the east boundary of the township for a distance of 5 miles from the south boundary. These are run and monumented as true lines. The remaining section lines are all run by random and true between the established section corners. This produces the rectangular sections, 25 of which contain 640 acres each, within allowable limits. The sections along the north and west boundaries are subdivided on a plan for certain lottings to absorb the convergency and the excess or deficiency in the measurements. These sections provide a maximum number of aliquot parts (160-, 80-, and 40-acre units) or regular subdivisions of a section, the remainder being shown as lots for which the contents are computed according to the field measurements.

## Organization

**1-31.** The reorganization of the Federal Government has involved necessary changes in the administrative practice consistent with the established technical procedure. Note that throughout the Manual, references to the administrative practice are purposely stated in general terms; this is done to avoid diverting the attention from a strictly technical treatment of the surveying subjects.

Official surveys are conducted by the BLM’s State Offices under the direction of the State Office Chief Cadastral Surveyor. The authority over field operations is limited by instructions issued by the Director. The State Offices, with locations, are:



*Alaska* State Office at Anchorage, Alaska.

*Arizona* State Office at Phoenix, Arizona.

*California* State Office at Sacramento, California (administers official surveys in California and Hawaii).

*Colorado* State Office at Denver, Colorado.

*Idaho* State Office at Boise, Idaho.

*Montana* State Office at Billings, Montana (administers official surveys in Montana, North Dakota, and South Dakota).

*Nevada* State Office at Reno, Nevada.

*New Mexico* State Office at Santa Fe, New Mexico (administers official surveys in Kansas, New Mexico, Oklahoma, and Texas).

*Oregon* State Office at Portland, Oregon (administers official surveys in Oregon and Washington).

*Utah* State Office at Salt Lake City, Utah.

*Wyoming* State Office at Cheyenne, Wyoming (administers official surveys in Wyoming and Nebraska).

Headquarters for official surveys in the remaining States are at the Eastern States Office, Springfield, Virginia.

## The Public Land States

**1-32.** Thirty States have been created out of the public domain. In those where the public land surveys have been substantially completed, excepting Oklahoma, the original records have been transferred to the States upon closure of the Surveyor General's office. In most cases, the duplicate original records of surveys prior to public survey office closures are retained in the Washington Office and are on file at the Eastern States Office of the BLM at Springfield, Virginia.

The Director of the BLM has administrative authority in questions relating to the re-marking of the boundaries of the remaining Federal interest land, where

resurvey is required, and to the extension of surveys to include parcels of Federal land omitted from the official surveys.

The following is a list of the States formed from the public domain, giving the date of admission, a citation of the primary enabling act, statehood act, admission act, authorization act, resolution, or President's proclamation as applicable (amendment acts and supplemental acts are not listed) in the United States Statutes at Large, and the present location of the original records, except as noted in sections 9-32 and 9-84, of public land surveys:

*Alabama.* Included in the territory of the original 13 States and portions acquired under the Louisiana Purchase in 1803; admitted into the Union December 14, 1819 (3 Stat. 489 and 608); records with the Department of Conservation and Natural Resources at Montgomery.

*Alaska.* Purchased from Russia in 1867; admitted into the Union January 3, 1959 (72 Stat. 339; 73 Stat. c16); records in the State Office of the BLM at Anchorage.

*Arizona.* Included in the lands ceded by Mexico in 1848 and the Gadsden Purchase in 1853; admitted into the Union February 14, 1912 (36 Stat. 557; 37 Stat. 39 and 1728); records in the State Office of the BLM at Phoenix.

*Arkansas.* Acquired under the Louisiana Purchase in 1803 and admitted into the Union June 15, 1836 (5 Stat. 50); records with the Commissioner of State Lands at Little Rock.

*California.* Ceded by Mexico in 1848 and admitted into the Union September 9, 1850 (9 Stat. 452); records in the State Office of the BLM at Sacramento, and National Archives and Records Administration (NARA) Records Center at San Bruno.

*Colorado.* Acquired largely under the Louisiana Purchase in 1803, but including additional land, title to which was quieted through treaty with Spain in 1819, with other lands annexed with Texas in 1845, and lands ceded by Mexico in 1848; admitted into the Union August 1, 1876 (18 Stat. 474; 19 Stat. 665); records in the State Office of the BLM at Denver.

*Florida.* Ceded by Spain in 1819 and admitted into the Union March 3, 1845 (5 Stat. 742); records with the Division of State Lands, Bureau of Survey and Mapping, at Tallahassee.

*Idaho.* Acquired with the Oregon Territory, title to which was established in 1846, and admitted into the Union July 3, 1890 (26 Stat. 215); records in the State Office of the BLM at Boise.

*Illinois.* Included in the territory of the Thirteen Original States and admitted into the Union December 3, 1818 (3 Stat. 428 and 536); records in the Illinois State Archives, Office of the Secretary of State, at Springfield.

*Indiana.* Included in the territory of the Thirteen Original States and admitted into the Union December 11, 1816 (3 Stat. 289 and 399); records with the Commission on Public Records at Indianapolis.

*Iowa.* Acquired under the Louisiana Purchase in 1803 and admitted into the Union December 28, 1846 (9 Stat. 117); records with the Secretary of State, Corporate Division, at Des Moines.

*Kansas.* Acquired under the Louisiana Purchase in 1803 (additional lands annexed with Texas in 1845); admitted into the Union January 29, 1861 (12 Stat. 126); records with the Historical Archives at Topeka.

*Louisiana.* Included in the Louisiana Purchase in 1803; boundary extended to include additional lands, title to which was quieted through treaty with Spain in 1819; admitted into the Union April 30, 1812 (2 Stat. 641 and 701); records with the Division of Administration, State Land Office, at Baton Rouge.

*Michigan.* Included in the territory of the Thirteen Original States and admitted into the Union January 26, 1837 (5 Stat. L 49 and 144); records with the Chief, Real Estate Division, Department of Natural Resources, at Lansing.

*Minnesota.* Included in the territory of the Thirteen Original States (additional lands acquired under the Louisiana Purchase in 1803); admitted into the Union May 11, 1858 (11 Stat. 166 and 285); records with the Secretary of State, Business Services Division, at Saint Paul.

*Mississippi.* Included in the territory of the Thirteen Original States and admitted into the Union December 10, 1817 (3 Stat. 348 and 472); records with the Secretary of State's Office at Jackson.

*Missouri.* Acquired under the Louisiana Purchase in 1803 and admitted into the Union August 10, 1821 (3 Stat. 545, 645, and 797); records with the Missouri Department of Natural Resources, Geological Survey—Land Survey at Rolla.

*Montana.* Acquired under the Louisiana Purchase in 1803 and with the Oregon Territory, title to which was established in 1846; admitted into the Union November 8, 1889 (25 Stat. 676; 26 Stat. 1551); records in the State Office of the BLM at Billings and NARA Records Center at Denver, Colorado.

*Nebraska.* Acquired under the Louisiana Purchase in 1803 and admitted into the Union March 1, 1867 (13 Stat. 47; 14 Stat. 391 and 820); records with the State Surveyor at Lincoln.

*Nevada.* Ceded by Mexico in 1848 and admitted into the Union October 31, 1864 (13 Stat. L 30 and 749); records in the State Office of the BLM at Reno and NARA Records Center at San Bruno, California.

*New Mexico.* Included in the lands annexed with Texas in 1845, with lands ceded by Mexico in 1848, and the Gadsden Purchase in 1853; admitted into the Union January 6, 1912 (36 Stat. 557; 37 Stat. 39 and 1723); records in the State Office of the BLM at Santa Fe.

*North Dakota.* Included with lands acquired under the Louisiana Purchase in 1803; admitted into the Union November 2, 1889 (25 Stat. 676; 26 Stat. 1548); records with the State Water Commission at Bismarck.

*Ohio.* Included in the territory of the Thirteen Original States and admitted into the Union November 29, 1802 (2 Stat. 173 and 201); records with the Auditor of State at Columbus.

*Oklahoma.* Acquired under the Louisiana Purchase in 1803 and with lands annexed with Texas in 1845; admitted into the Union

November 16, 1907 (34 Stat. 267; 35 Stat. 2160); records in the Eastern States Office of the BLM at Springfield, Virginia.

*Oregon.* Included in the Oregon Territory, title to which was established in 1846; admitted into the Union February 14, 1859 (11 Stat. 383); records in the State Office of the BLM at Portland.

*South Dakota.* Included with lands acquired under the Louisiana Purchase in 1803; admitted into the Union November 2, 1889 (25 Stat. 676; 26 Stat. 1549); records with the State Archives at Pierre.

*Utah.* Ceded by Mexico in 1848 and admitted into the Union January 4, 1896 (28 Stat. 107; 29 Stat. 876); records in the State Office of the BLM at Salt Lake City.

*Washington.* Included in the Oregon Territory, title to which was established in 1846; admitted into the Union November 11, 1889 (25 Stat. 676; 26 Stat. 1552); records in the Oregon State Office of the BLM at Portland, Oregon.

*Wisconsin.* Included in the territory of the Thirteen Original States and admitted into the Union May 29, 1848 (9 Stat. 56, 178 and 233); records with the Board of Commissioners of Public Lands at Madison.

*Wyoming.* Included with lands acquired under the Louisiana Purchase in 1803, with lands

annexed with Texas in 1845, with lands included in the Oregon Territory, title to which was established in 1846, and with lands ceded by Mexico in 1848; admitted into the Union July 10, 1890 (26 Stat. 222); records in the State Office of the BLM at Cheyenne.

## The Non-Public Land States

**1-33.** Twenty States and the District of Columbia were not created out of the public domain. Generally, any Federal interest lands in those States fall into the category of acquired lands. The survey original records for the States formed from the original colonies, 18 Eastern States, and the District of Columbia are retained at the Eastern States Office of the BLM at Springfield, Virginia. The duplicate original records are held at local government offices.

The two remaining non-public land States are Hawaii and Texas. The survey original records for Hawaii are retained at the California State Office of the BLM at Sacramento and the duplicate original records are held in the Washington Office and are on file at the Eastern States Office at Springfield. The survey original records for Texas are held in the NARA and the duplicate original records are held in the Washington Office and are on file at the Eastern States Office at Springfield.

The Director of the BLM has administrative authority in questions relating to the official marking of the boundaries of Federal interest lands, where survey or resurvey is required, and to the extension of official surveys to include parcels of land to be acquired or exchanged.

## Chapter I Notes

The notes presented here elaborate on or continue to discuss the topics presented in chapter I. The section numbers correspond to the section numbers in the chapter and are followed by "(n)" to indicate that they are additional notes.

### Purpose and Scope of the Manual

**1-5(n).** Corners established in an administrative survey by BLM employees, by other Federal departments and agencies, or by or for an Indian tribe, unless subject to special enactment, cannot be considered official United States corners unless and until they are accepted by the authorized officer of the BLM. In the absence of official acceptance by the BLM, users rely on such corners at their own peril (*Longview Fibre Co.*, 135 IBLA 170, 185 (1996)).

### Source of Law

**1-7(n).** In cases of Federal interest lands that at some point in time were not in Federal control, such as acquired lands, lands beneath navigable waters, and foreign sovereign private land grants, the location of the boundary by application of Federal laws and rules is but an intermediate step of the official survey. In most such cases, boundaries were originally defined or confirmed by the application of Federal laws and rules, but during a resurvey, the application of State or foreign sovereign laws and rules not consistent with Federal laws and rules may be required, including evaluating unwritten rights. In some cases the original boundaries were created under the law of a foreign sovereign. Guidance on these subjects is purposely stated in very general terms. Special instructions should be issued in cases requiring the interpretation of State or foreign sovereign laws.

### Basic Surveying Principles and Practices

**1-8(n).** Details of the general plan and its methods go beyond the scope of textbooks on surveying. The application of the general plan to the land tenure system requires an understanding of the application of the rules of evidence governing the location of boundaries. Surveys of Federal interest lands require detective work for ancient marks, which are often obscured by poor materials or workmanship, or both, and subject to aging, misidentification, and destruction. Surveying within the land tenure system of the various States requires knowledge of (1) record systems stretching back over centuries, (2) the availability of the records in specific locales, (3) whether surveys and related records were subject to

recordation or not, and (4) the relevancy of records to each boundary location case.

Experience has proven that knowledge of the proper use of current and past instrumentation to obtain and observe direction and distance is a prerequisite to properly executing a cadastral survey according to the general plan and its methods. Thorough discussion of past and present field procedures and mathematical processes for determining direction of lines is readily available in instrument manuals, textbooks, and previous editions of this Manual, and is therefore omitted in this edition.

### Development of the Manual

**1-10(n).** Originally, the Land Ordinance of May 20, 1785, itself served as the survey instructions. There is no record of additional instructions to or from the Chief Geographer.

More detailed regulations and instructions, improving the system for greater accuracy, permanency, and uniformity, were issued in book form as Manuals. These early Manuals of instructions were prepared by Surveying District Surveyors General, issued to their Deputy Surveyors, and pertained to a single district. The earliest known and extant instructions by a Surveyor General were issued in 1804 by Jared Mansfield. Knowledge of the specific Manual requirements for original surveys is key to the proper performance of subsequent surveys.

**1-11(n).** The early Manuals emphasized original surveys and contained little mention of retracements or resurveys. The need for increased instruction for the resurvey of public lands was marked by passage of the General Resurvey Act of March 3, 1909, as amended June 25, 1910 (43 U.S.C. 772). Retracement and resurvey responsibilities were further expanded with passage of the Act of September 21, 1918 (43 U.S.C. 773), which provides a general authorization for the definition of boundaries of those lands to which title has passed from Federal control. The first full Manual discussion of resurveys was contained in the Advance Sheets, published June 16, 1919, and became part of the Manual of 1930.



## The Manual Supplements

**1-12(n).** (1) The subject matter under this title first appeared in the decisions of the Department of the Interior in 1883 (1 Pub. Lands Dec. 339, first edition) and 1887 (1 Pub. Lands Dec. 671, revised edition). There have been several revisions and extensions of this guide.

### Definitions

**1-13(n).** Section 2 of Title 43 of the United States Code assigns responsibility to the Secretary to consider for survey and sale that which the United States acquired from another sovereign and determine what was properly public lands of the United States and what was properly related to “private land claims” (e.g., grants from the Spanish Crown or Mexican Government). Depending on how the public lands were classified and/or disposed of, different survey principles might apply. For instance, with respect to mining claims and entries under the 1872 Mining Law, lode claims and tunnel sites were described by the metes-and-bounds method, while placer claims and millsites were described by the rectangular survey system. If public domain lands or “public lands” were classified as “townsites,” the GLO would accept entries that were described in terms of the rectangular survey system, metes-and-bounds, or lot and block methods. By contrast, for public lands classified as, for instance, “agricultural lands” or “grazing lands” or “timber lands,” the GLO would only accept entries or claims described by the rectangular survey system.

The acquisitions from foreign sovereign powers were subject to prior rights and confirmation by the Federal Government.

Lands to which this Manual and the authority of official surveys apply include the following three classes, all falling within the borders of the original public domain (figure 1-1) or otherwise under the direct political jurisdiction of the United States:

(1) **Public domain lands:** Lands owned and administered by the United States within the original public domain that have remained in Federal ownership.

(2) **Acquired lands:** Lands owned and administered by the United States that were not part of the original public domain or such lands that were part of the original public domain but that

were alienated and later returned to Federal ownership.

(3) **Non-Federal, private, or alienated<sup>7</sup> lands:** Lands not owned or administered by the United States that were not part of the original public domain or lands that were part of the original public domain that were alienated.

The spectrum of Federal interest in land includes possessory interests, such as ownership in fee simple; an estate held in trust for a beneficiary, such as Indian trust land; or fractional interests such as split estates, reserved mineral rights on patented land (including fractional interests in minerals); and nonpossessory interests in the use of land, such as easements, rights-of-way, leases, or permits.

Federal interests are often physically intermingled with non-Federal ownership. The surveyor must ascertain the land status of every parcel surveyed as an integral part of any boundary determination. For surveys where public domain land is not involved, the procedures must necessarily be brought into harmony with the appropriate State or foreign sovereign law and the decisions of the courts of competent jurisdiction.

In general usage, the status of any particular parcel of land is obtained from an accumulation of information relating to the parcel. Examples of status information are: the legal description; whether surveyed or unsurveyed; rights or privileges attached, if any; whether classified as mineral or agricultural lands; applicable withdrawals, orders, or special laws; and other pertinent information that may influence the operation of the laws related to the use or disposal of the parcel. Land status does influence which of various boundary laws and rules are controlling and the court of competent jurisdiction for resolution of disputes.

### Administration

**1-14(n).** Private or other non-Federal landowners wishing to contribute funds for an official survey should consult the relevant regulations and contact the Chief Cadastral Surveyor of the BLM State Office with jurisdiction where the land is located.

<sup>7</sup> Alienated lands are non-Federal lands that have been conveyed out of Federal ownership through valid operation of law. Much of the original public domain has been alienated; however, where a Federal interest in the land remains, the land has been returned to Federal ownership, or the land has a reversionary interest or is anticipated to be acquired, official surveys are used to identify the boundaries.



The lack of specific instruction by this Manual for surveys of Federal lands outside the original public domain is not intended to inhibit appropriate action by the Federal Government to mark and define boundaries of Federal interest lands. Special instructions for such surveys will be issued upon receipt of a proper request. Such instructions would address technical and administrative matters. As a general rule, however, administrative aspects of such surveys would follow the procedures outlined in this Manual.

## Navigable Waters

**1-16(n).** The United States held the lands beneath navigable waters in the territories “in trust” for the future States that would be created. Title to the lands beneath navigable waters passed to the State upon statehood unless a contrary intention was definitely declared or otherwise rendered in clear and specific words, or unless a prior confirmed claim embraces the lands beneath navigable waters. Some States have conveyed title to their lands beneath navigable waters or portions thereof.

Lands beneath navigable waters do not include the beds of streams in lands now or heretofore constituting a part of the public lands of the United States if such streams were not meandered in connection with the public survey of such lands under the laws of the United States and if the title to the beds of such streams was lawfully patented or conveyed by the United States or any State to any person (67 Stat. 29; 43 U.S.C. 1301(f)). (See discussions on meandering in chapter III and water boundaries in chapter VIII.)

## Surveying and Survey Administration Laws

**1-20(n).** The Land Ordinance of May 20, 1785, provided for townships 6 miles square laid out in ranges extending westward from the Ohio River. The townships were numbered from south to north and the ranges from east to west. The region embraced by the surveys under this law forms a part of the State of Ohio. In these initial surveys, all lines were run on the true meridian. Only exterior lines of the townships were surveyed and mile corners established. Plats were marked by townships with protracted subdivisions, called lots, of 1 mile square.

The Land Ordinance directed that surveys were to be made by surveyors appointed by the States, under the direction of the Chief Geographer of the United States. The Geographer was to transmit the survey plats to the Board of Treasury, which was to record the same and conduct the land sales. The whole expense of surveying was not to exceed \$2 per mile. Land was to be sold for

not less than \$1 per acre cash, in units of 640 acres or more.

The Northwest Territory Ordinance of July 13, 1787, was the first general legislation by the Congress on the subject of real property. Since its passage, free and unconditional alienation is the rule of the Federal Government in the disposal of the public domain. The Ordinance contains the basic propositions as to land tenures of the laws of the United States and of most of the States and became the foundation of the same statutes in all the public land States and territories. By this Ordinance, new States were to be admitted on an equal footing with the original States (affirmed by the Act of August 7, 1789 (1 Stat. 50), under the Constitution).

The Act of September 2, 1789 (1 Stat. 65), created the Department of Treasury. The Secretary of the Treasury was to execute the services relating to the sale of the lands belonging to the United States, including the survey function.

The Act of May 18, 1796 (1 Stat. 464; 43 U.S.C. 52, 751, and 931), provides that half of the townships were to be subdivided into four section blocks, and the rule for numbering of sections within the township was changed to that which is practiced today.

This Act also created the office of Surveyor General within the Department of Treasury, charged with the duty of all surveying and platting of the public lands. The Surveyor General begins receiving written instructions from the Secretary of the Treasury. The Surveyor General was to engage skillful surveyors as his deputy surveyors; frame regulations and instructions for the governance of his deputies; and prepare three survey plats, two sets of field notes and one set of descriptive notes for each township survey to be submitted to the Secretary who was to direct the land sales.<sup>8</sup> The Secretary of State was to record the conveyances of land, called patents. The whole expense of surveying was not to exceed \$3 per mile. Land was sold on terms, for not less than \$2 per acre, in units of 640 acres or more.

The Act of March 1, 1800 (2 Stat. 14), established the important principle that the lines run and the corners

<sup>8</sup> Section 1 states: “The Secretary of the Interior or such officer as he may designate shall engage a sufficient number of skillful surveyors as his deputies, to whom he is authorized to administer the necessary oaths upon their appointments. He shall have authority to frame regulations for their direction, not inconsistent with law or the instructions of the Bureau of Land Management, and to remove them for negligence or misconduct in office” (Rev. Stat. 2223; 43 U.S.C. 52).

marked on the ground and returned in the field notes and on the plat by the Surveyor General shall be considered to be the lines and corners of the parcels so identified, even though not in conformity to the precise theoretical positions contemplated by the survey laws, or not appearing to correspond with the plat, or found at unequal distances from the respective corners. It thus established a hierarchy of boundary evidence, the foremost and dispositive of which were the actual marks on the ground. This principle was amplified by the Act of February 11, 1805.

The Act also set the precedent that each legal subdivision on the plats returned by the Surveyor General shall be considered as containing the exact quantity expressed on the plat. Thus by this Act, the plat is the source of the quantity of acres for administrative purposes, often called legal acres. This was important in calculating acreage-based costs for entries, grants, and selections.

The Act of March 26, 1804 (2 Stat. 277), made the necessary provision for the disposal of the public lands in the Indiana Territory. This is an early example of the policy to extinguish Indian title to the public domain, followed by the extension of the surveys and settlement.

The Act of February 11, 1805 (2 Stat. 313; 43 U.S.C. 752), fixes the corners marked (monumented) in position regardless of any errors, requires that any corners of half- or quarter-section not marked (monumented) in the original survey shall be established at midpoint and on line, fixes the lines actually run and marked as the proper (true) boundary lines, and establishes the length of the lines returned by the Surveyor General (now Chief Cadastral Surveyor) as the true length. These provisions are the basis of single and double proportion as the proper method of restoring lost corners and also fix the method of subdividing sections. The precedent for these important principles is the Act of March 1, 1800 (2 Stat. 14).

The Act also establishes the quantity or area of land returned as the true quantity and that a half-section or quarter-section of a full 640-acre section contains 320 or 160 acres, respectively.

This Act was passed to remedy weaknesses identified in the subdivision of the four section blocks. Prior to the Act, the sections within the blocks were being relocated to obtain the record quantity by use of the record bearings and distances. This method resulted in four parallelograms and gaps and overlaps. The Act stated that the purchasers are to take to the corners marked

and returned by the Surveyor General and that it was not material what quantity the section may actually contain. This method eliminated conflicts between the sections.

The Act of March 3, 1811 (secs. 2 and 5, 2 Stat. 662), provided for a departure from the system of rectangular surveys. It applied only to lands adjacent to any river, lake, creek, bayou, or water course in the Orleans Territory. These "Riverfront Tracts" or "French Tracts" are one example of many when Congress enacted deviations away from the rectangular system. The records of official surveys and resurveys cover special cases such as these.

The Act of April 25, 1812 (2 Stat. 716; 43 U.S.C. 2, 6, 12, 14, and 17), created the GLO as a bureau within the Department of the Treasury. Its chief officer was the Commissioner of the GLO, "whose duty it shall be, under the direction of the head of the Department, to superintend, execute, and perform all such acts and things touching or respecting the public lands of the United States, and other lands patented or granted by the United States, as have heretofore been directed by law to be done or performed in the office of the Secretary of State, of the Secretary and Register of the Treasury, and of the Secretary of War, or which shall hereafter by law be assigned to the said office."

The Act of April 24, 1820 (3 Stat. 566; 43 U.S.C. 753), directs the sale of half-quarter sections (80-acre units) and that sections and fractional sections containing 160 acres and upward shall, as nearly as practicable, be subdivided into half-quarter sections under such rules and regulations as may be prescribed by the Secretary of the Treasury.

The Act of May 29, 1830 (4 Stat. 417; Rev. Stat. 2413; 43 U.S.C. 774), provides that whenever the President is satisfied that forcible opposition has been offered, or is likely to be offered, to any surveyor or deputy surveyor in the discharge of his duties in surveying the public lands, it may be lawful for the President to order the marshal of the State or district, by himself or deputy, to attend such surveyor or deputy surveyor with sufficient force to protect such officer in the execution of his duty, and to remove force should any be offered.

The Act of April 5, 1832 (4 Stat. 503; 43 U.S.C. 753), determined that the 40-acre aliquot part and the Government lot are the smallest legal subdivision under the public land laws. It directs the subdivision of the lands into quarter-quarters (40-acre units), and that

fractional sections will be subdivided under rules and regulations prescribed by the Secretary of the Treasury. The Secretary directed that fractional sections containing less than 160 acres, or the residuary portion of a fractional section, after the subdivision into as many quarter-quarter sections as it is susceptible of, may be subdivided into lots, each containing the quantity of a quarter-quarter section as nearly as practicable. This is to be done by laying down the lines of subdivision so that they will be 20 chains wide. These distances are to be marked on the plat of subdivision, as are also the areas of the quarter-quarters and residuary fractions.

The Act of June 30, 1834 (4 Stat. 730; Rev. Stat. 2118; 25 U.S.C. 180), provides that every person who surveys or attempts to survey any lands belonging, secured, or granted by treaty with the United States to any Indian tribe, or to designate any of the boundaries by marking trees or otherwise, is liable to a penalty.

The Act of July 4, 1836 (5 Stat. 107; 43 U.S.C. 2, 6, and 18), provided for the reorganization of the GLO such that the executive duties of the office became subject to the supervision and control of the Commissioner of the GLO under the direction of the President. However, in practice, the Secretary of the Treasury still had supervisory control over the Office. The Principal Clerk of the Surveys in the GLO provided overall direction for the public land surveys.

The Act of June 12, 1840 (5 Stat. 384; Rev. Stat. 2218; 43 U.S.C. 54), directed that once the surveying was completed, all the plats, field notes, maps, records, and other papers appertaining to land titles produced in a State be delivered to the Secretary of State or such officer as may be authorized to receive them for the respective State.<sup>9</sup> The Office of Surveyor General in every such district then ceased operation and the Commissioner assumed the duties.

The Act of August 3, 1846 (sec. 5, 9 Stat. 51), as amended by the Isolated Tract Act of February 26, 1895 (28 Stat. 687; Rev. Stat. 2455; 43 U.S.C. 1171 (repealed sec. 703(a) of Public Law 94-579)), provided for survey and sale of isolated or disconnected tracts or parcels of the public domain. This included unsurveyed islands.

The Act of January 22, 1853 (10 Stat. 152; Rev. Stat. 2219; 43 U.S.C. 53, 55, and 56), provides that in all cases where an Office of Surveyor General was discontinued, all the Surveyor General's authority transferred

to the Commissioner of the GLO (now the Director of the BLM).

By this Act, and under the authority and direction of the Chief Cadastral Surveyor, any surveyor or other agent of the United States shall have free access to any plats, field notes, maps, records, and other papers transferred to State authorities, for the purposes of taking extracts therefrom or making copies thereof without charge of any kind.

The Act of March 3, 1853 (10 Stat. 245; Rev. Stat. 2223; 43 U.S.C. 52), provides that the Secretary of the Interior or such officer as he or she may designate shall cause to be surveyed all foreign sovereign private land claims after they have been confirmed by authority of Congress, so far as may be necessary to complete the survey of the public lands.

The same Act (Rev. Stat. 2410; 43 U.S.C. 770) provides that departures may be made from the system of rectangular surveys whenever it is not feasible or economical to extend the rectangular surveys in the regular manner or whenever such departure would promote the beneficial use of lands.

The Act of May 30, 1862 (sec. 10, 12 Stat. 409), as amended by the Act of August 20, 1894 (28 Stat. 423; Rev. Stat. 2401; 43 U.S.C. 759), provides that it is lawful when the settlers in any township not mineral or reserved by the Government, or when the owners or grantees of public lands under any law thereof, desire an official survey and shall file an application therefore, and shall deposit a sum sufficient to pay for such survey together with all expenditures incident thereto, without cost or claim on the United States, the BLM shall survey such township or such public lands owned by said grantees of the Government.

The value of small islands was considered so inconsiderable as not to warrant incurring the expense of surveys because the proceeds from such sales would not reimburse the Government for its costs. In order to relieve the public from this expense and still enable individuals to obtain title to unsurveyed islands, the party desiring the survey was required to pay the cost of survey. However, the payment conferred no preference in the purchase of the island.

The Act of July 23, 1866 (43 Stat. 1144; 43 U.S.C. 987), provides that the BLM shall examine the segregation maps and survey of the swamp and overflowed lands made by the State of California, and where found to conform to the system of surveys adopted by the United

<sup>9</sup> The records turned over to the States were the original field notes and plats previously retained by the Surveyor General.

States, shall construct, approve, and file township plats accordingly.

The Act of March 3, 1879 (20 Stat. 394; Rev. Stat. 441; 43 U.S.C. 1457), provides that the Secretary of the Interior is charged with the supervision of public business relating to the following subjects and agencies: Alaska Railroad; Alaska Road Commission; Bountylands; Bureau of Land Management; United States Bureau of Mines; Bureau of Reclamation; Division of Territories and Island Possessions; Fish and Wildlife Service; United States Geological Survey (USGS); Indians; National Park Service; petroleum conservation; and public lands, including mines.

The Act of May 17, 1884 (23 Stat. 24), extended the mining laws to Alaska.

The Act of July 5, 1884 (23 Stat. 103; 43 U.S.C. 1071–1073 repealed), as amended, placed the control of the survey and disposal of all of the reduced or abandoned military reservations under the Secretary of the Interior.

The Act of February 8, 1887 (24 Stat. 388), authorized the President to have lands allotted and surveyed for individual Indians. Many allotments surveyed by agents of the United States Indian Service were not approved by the GLO/BLM nor filed in the United States survey records. Allotment surveys under the direction and control of the GLO/BLM were officially approved and filed.

The BLM Director has discretion to correct a resurvey of patented land where a substantial allegation of fraud or mistake is made (*19 Op. Atty Gen. 126* (1888)).

The Act of June 11, 1896 (29 Stat. 435; 43 U.S.C. 38), instructs the USGS, when making topographic surveys west of the 95<sup>th</sup> meridian, to mark on the ground iron or stone posts in each township or equivalent area.

The Act of June 4, 1897 (30 Stat. 34; 16 U.S.C. 474), provides that the surveys, field notes, and plats returned from the survey of public lands designated as national forests undertaken under the supervision of the Director of the USGS shall be approved by the Director of the BLM.

The Act of June 17, 1902 (32 Stat. 388; 43 U.S.C. 434), provides for lands within reclamation projects to be subdivided to not less than 10 acres by the officers of the Bureau of Reclamation and the surveys shall be submitted for approval and filing by the BLM.

The Act of February 1, 1905 (33 Stat. 628; 16 U.S.C. 472), provides that the Secretary of Agriculture shall execute all laws affecting public lands reserved as National Forest Lands excepting such laws as affect the surveying, reconveying, or patenting of any of such lands.

The Act of May 17, 1906, as amended (34 Stat. 197; 43 U.S.C. 270-1 repealed; see 43 U.S.C. 1634), authorized Alaska Native allotments and surveys.

The Act of June 27, 1906 (34 Stat. 519; 43 U.S.C. 561), provides for townsite surveys within reclamation projects to be submitted for approval and filing by the BLM.

The Act of May 27, 1908 (35 Stat. 317, 348), provides “for the purchase of metal monuments to be used for public land survey corners wherever practicable.”

The Act of March 4, 1909, as amended (63 Stat. 89, 95; Rev. Stat. 2412; 108 Stat. 1796, 2147; 18 U.S.C. 1859), provides that whoever, by threats or force, interrupts, hinders, or prevents the surveying of the public lands, or of any foreign sovereign private land claim which has been or may be confirmed by the United States, by the persons authorized to survey the same in conformity with the instructions of the Director of the BLM, shall be fined under this title or imprisoned, or both.

The Act of August 10, 1912 (37 Stat. 287; repealed October 23, 1962), provided that the survey of land within forest reserve chiefly valuable for agriculture could be made by an employee of the Forest Service under the direction of the Surveyor General. These are commonly called Forest Homestead Entry Surveys.

Under the Economy Act of May 21, 1920, as amended (41 Stat. 607, 613; 31 U.S.C. 1535), the expertise and services of the BLM may be lawfully procured by another Federal department or agency to survey or resurvey Federal interest land, including acquired land that is administered by the head of any Federal department or agency.

The Act of March 3, 1925 (43 Stat. 1144; 43 U.S.C. 51 superseded), provided for the reorganization of the public survey offices. The Offices of Surveyor General were abolished, effective July 1, 1925, and the administration of all activities theretofore in charge of the Surveyors General, including all records, were transferred to and consolidated with the field surveying service, under the jurisdiction of the United States Supervisor of Surveys,



who thereafter administered the same in association with the surveying operations in his charge and under regulations as the Secretary of the Interior provided.

The administrative plan that was set up through the Act of March 3, 1925, continued in operation until displaced by the reorganization of July 16, 1946, wherein the GLO was abolished and its functions transferred to the BLM.

The Act of July 7, 1943, as amended (57 Stat. 380; 44 U.S.C. 3301), defines Federal records (also called official records) as all papers and maps made or received by an agency of the United States in connection with the transaction of public business and preserved because of the administrative, legal, fiscal, or informational value of data in them.

The Federal Records Act of 1950, as amended (64 Stat. 586; 44 U.S.C. 3101), requires the preservation of Federal records vital to the protection of the legal and financial rights of the Government and individuals affected.

The Submerged Lands Act of 1953 (43 U.S.C. 1301 et seq. and 1311 et seq.) uses the terms “navigable” and “navigability” for the purpose of determining title to lands beneath navigable waters, as between the United States and the several States.

The Alaska Statehood Act of July 7, 1958 (72 Stat. 339, 344; 48 U.S.C. note preceding section 21), modifies public land survey law, in Alaska, by allowing selected land to be conveyed by tentative approval prior to survey. Subject to valid existing rights, the force and effect of such a tentative approval is to convey to and vest in the State exactly the same right, title, and interest in and to the selected lands the State would have received had it been issued a patent by the United States. The survey of the exteriors of the selections only, without any interior subdivision, is permissible. The boundaries of the lands as defined and conveyed by the tentative approval shall not be altered but may then be redescribed, if need be, in reference to the plat of survey. Upon survey of lands covered by the tentative approval, a confirmatory patent thereto shall be issued to the State. This Act is applicable only to land in Alaska.

The Public Land Administration Act of July 14, 1960 (section 103; 74 Stat. 506; 43 U.S.C. 1364), provides that the Secretary of the Interior may accept contributions for cadastral surveying performed on Federally controlled or intermingled lands. This Act was repealed by section 705(a) of FLPMA on October 21, 1976. Section 307(c) of FLPMA (43 U.S.C. 1737(c)) substantially reenacts 43 U.S.C. 1364.

The Alaska Native Claims Settlement Act (ANCSA) of December 18, 1971 as amended (85 Stat. 688; 43 U.S.C. 1612, 1621), provides that the Secretary, save explicit exceptions, shall survey all Native Alaska Village Corporation withdrawals, selections, and conveyances in conformance as nearly as practicable to the PLSS.

ANCSA also modifies public land survey law by allowing selected land to be conveyed by interim conveyance prior to survey. Subject to valid existing rights, the force and effect of such an interim conveyance is to convey to and vest in the recipient exactly the same right, title, and interest in and to the selected lands as the recipient would have received had they been issued a patent by the United States. In addition, the Act authorizes original surveys to monument only exterior boundaries of the areas selected or designated areas at angle points and at intervals of approximately 2 miles on straight lines. The Act states that no ground survey or monumentation will be required along meanderable water boundaries and conveyances can be based upon protraction diagrams. Upon survey of lands covered by the interim conveyance, a confirmatory patent thereto shall be issued to the Native Corporation. This Act is applicable only to land in Alaska.

The Federal Land Policy and Management Act of October 21, 1976 (90 Stat. 2743, 2747; 43 U.S.C. 1701, 1711), provides that the Secretary shall prepare and maintain, on a continuing basis, an inventory of all public lands and shall ascertain the boundaries of the public lands; provide means of public identification thereof including, where appropriate, signs and maps; and provide State and local governments with data from the inventory for the purpose of planning and regulating the uses of non-Federal lands in proximity of such public lands.

Under FLPMA, a tract of public lands<sup>10</sup> or interests therein or a tract of land or interests therein within the National Forest System may be disposed of by exchange; the costs or other responsibilities or requirements shall include costs or other requirements associated with land surveys (90 Stat. 2756; 102 Stat. 1087; 43 U.S.C. 1716).

Under FLPMA, unsurveyed islands may be surveyed and conveyed if the applicant State or its political sub-

---

<sup>10</sup> Under section 103 of FLPMA, the term “public lands” means any land and interest in land owned by the United States within the several States and administered by the Secretary of the Interior through the Bureau of Land Management, without regard to how the United States acquired ownership, except: (1) land located on the Outer Continental Shelf; and (2) lands held for the benefit of Indians, Aleuts, and Eskimos” (43 U.S.C. 1702(e)).



division donates money or services for such survey and such services are conducted pursuant to criteria established and survey approval by the Director (43 U.S.C. 1721).

Under FLPMA, omitted lands, other than islands, are lands determined after survey to be erroneously or fraudulently omitted from the original surveys. Conveyance of such land shall not be made without a survey. The prospective recipient may donate money or services for the survey and such services are conducted pursuant to criteria established by the Director (43 U.S.C. 1721).

Under FLPMA, the Secretary may establish reasonable charges and commissions with respect to applications and other documents relating to the public lands. Such fees collected shall be made immediately available for program operations and remain available until expended (43 U.S.C. 1734).

The Secretary is authorized to enter into contracts for the use of aircraft and for supplies and services prior to the passage of an appropriation therefore for airborne cadastral survey operations of the BLM (43 U.S.C. 1738).

FLPMA permits the Secretary to issue a document of disclaimer of interest or interests in any lands in any form suitable for recordation, where the disclaimer will help remove a cloud on the title of such lands and where he or she determines (1) a record interest of the United States in lands has terminated by operation of law or is otherwise invalid; or (2) the lands lying between the meander line shown on a plat of survey approved by the BLM or its predecessors and the actual shoreline of a body of water are not lands of the United States; or (3) accreted, relicted, or avulsed lands are not lands of the United States (90 Stat. 2743, 2770; 43 U.S.C. 1745; 43 CFR 1864).

Under FLPMA, the Secretary of the Interior, or the Secretary of Agriculture, as applicable, shall specify the boundaries of each right-of-way (defined as an easement, lease, permit, or license to occupy, use, or traverse public lands granted for the purpose listed) as precisely as is practical. Rights-of-way shall be granted, issued, or renewed subject to such terms and conditions as the Secretary concerned may prescribe regarding extent, survey, and location, including reimbursements by the applicant for all reasonable administrative and other costs incurred (43 U.S.C. 1764).

The Alaska National Interest Lands Conservation Act (ANILCA) of December 2, 1980, as amended (94 Stat.

2438; 43 U.S.C. 1635; 94 Stat. 2447; 43 U.S.C. 1637), modified public land survey law by authorizing that no ground survey or monumentation shall be required on any parcel selected by and conveyed to the State of Alaska or to a Native Corporation or Native group.

This same Act, as amended (94 Stat. 2430; 102 Stat. 979; 43 U.S.C. 1631, 1635, 1637), provides that no agency or board of the Department of the Interior other than the BLM shall have authority to determine the navigability of a lake, river, or stream within an area selected by a Native or Native Corporation pursuant to the ANCSA or the ANILCA. The Secretary may issue a patent on protraction diagrams in lieu of field surveys. Any person or corporation receiving a patent on the basis of a protraction diagram shall receive any gain or bear any loss of acreage due to errors, if any, in such protraction diagram. This Act is applicable only to land in Alaska.

The National Forest System Lands Small Tracts Act of January 12, 1983 (96 Stat. 2535; 16 U.S.C. 521c-521i), authorized the Secretary of Agriculture to sell, exchange, or interchange certain National Forest System lands to resolve trespass situations on Federal land. Many parcels and rights-of-way were surveyed by agents of the United States Forest Service without receiving instructions from the BLM. Many of these Forest Service survey records are therefore not filed in the BLM survey recordkeeping system. The parcel and right-of-way surveys under the direction and control of the BLM or surveyed in conformance to the Manual are officially approved and filed.

The Alaska Submerged Lands Act of August 16, 1988, as amended (102 Stat. 979; 43 U.S.C. 1631), restated some existing public land survey laws and modified others.

Whenever the Secretary surveys land selected by an Alaska Native, a Native Corporation, or the State of Alaska pursuant to the ANCSA, the Alaska Statehood Act, or the ANILCA, lakes, rivers, and streams shall be meandered in accordance with the principles in the 1973 edition of the Manual.

If title to lands beneath navigable waters of a lake less than 50 acres in size or a river or stream less than 3 chains in width did not vest in the State pursuant to the Submerged Lands Act (43 U.S.C. 1301 et seq.), such lake, river, or stream shall not be meandered.

The Secretary is not required to determine the navigability of a lake, river, or stream that because of its size

or width is required to be meandered; to compute the acreage of the land beneath such lake, river, or stream; or to describe such land in any conveyance document. Ground survey or monumentation of meander lines is not required.

The specific terms, conditions, procedures, covenants, reservations, and other restrictions set forth in the document entitled, "Memorandum of Agreement between the United States Department of the Interior and the State of Alaska," dated March 28, 1984, were incorporated and ratified as to the duties and obligations of the United States and the State as a matter of Federal law. For any plat of survey approved after December 5, 1983, water bodies shall be meandered and segregated from the survey, in accordance with the principles contained in the 1973 edition of the Manual, as modified by this agreement, as the basis for determining acreage chargeability.

With respect to land in Alaska, the terms "navigable" and "navigability" mean navigable for the purpose of determining title to lands beneath navigable waters, as between the United States and the several States pursuant to the Submerged Lands Act of 1953 as amended (43 U.S.C. 1301 et seq.), the Alaska Submerged Lands Act of 1988 as amended, and section 6(m) of the Alaska Statehood Act.

The Act provides that whenever, either before or after the date of enactment of this section, the Secretary conveys land to an Alaska Native, a Native Corporation, or the State of Alaska pursuant to the ANCSA, the Alaska Statehood Act, or the ANILCA, which abuts or surrounds a meanderable lake, river, or stream, all right, title, and interest of the United States, if any, in the land under such lake, river, or stream lying between the uplands and the median line or midpoint, as the case may be,

shall vest in and shall not be charged against the acreage entitlement of such Native or Native Corporation or the State. The right, title, and interest vested in a Native or Native Corporation shall be no greater an estate than the estate conveyed in the land that abuts or surrounds the lake, river, or stream.

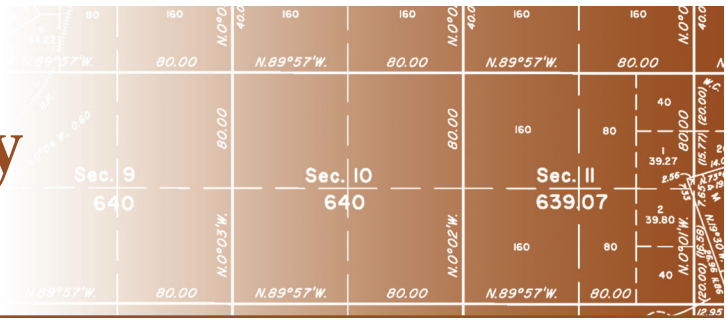
The execution of an interim conveyance or patent, as appropriate, by the BLM, which conveys an area of land selected by a Native or Native Corporation that includes, surrounds, or abuts a lake, river, or stream, or any portion thereof, shall be the final agency action with respect to a decision of the Secretary of the Interior that such lake, river, or stream is or is not navigable, unless such decision was validly appealed to an agency or board of the Department of the Interior on or before December 2, 1980. No agency or board of the Department of the Interior other than the BLM shall have authority to determine the navigability of a lake, river, or stream within an area selected by a Native or Native Corporation pursuant to the ANCSA or this Act. This Act is applicable only to land in Alaska.

The Act of November 10, 2003 (117 Stat. 1241, 1283), provides that the Secretary of Agriculture may authorize the expenditure or transfer of such sums as necessary to the BLM for the performance of cadastral surveys to designate the boundaries of National Forest System lands.

The Act of October 18, 2004 (118 Stat. 1357; 43 U.S.C. 1617 note), provides that an Alaska Native owner of restricted land may, subject to the approval of the Secretary, subdivide the restricted land in accordance with the laws of Alaska or applicable local platting authority. The survey should be submitted for approval and filing by the BLM.

## Chapter II

# Methods of Survey



## Introduction

**2-1.** Surveys require correct, consistent, and repeatable measurements. When conducting retracements of Federal interest lands, a thorough understanding of the gathering and reporting of measurements performed during prior surveys is essential. The surveyor should consult previous editions of the Manual, textbooks, and other reference sources for details on past and present measurement technology and techniques. The methods described in this chapter comprise the general framework for both the gathering and reporting of measurements for official surveys.

The measurements reported in the survey record are an important part of the overall survey. The results of original surveys, once filed, are considered unchangeable. In retracements and resurveys the measurements are subordinate to the original survey evidence; yet considerable problems can arise when erroneous survey measurements from the resurvey are incorporated into the official record. It is important to create survey records from accurate measurements to eliminate confusion and create a reliable record that can aid future surveyors in perpetuating land boundaries.

The Land Ordinance of May 20, 1785, established the Public Land Survey System (PLSS). The survey principles outlined in the Land Ordinance, defining the basis for making and reporting measurements in the PLSS, are still in effect today:

The geographer and surveyors . . . shall run and note all lines by the true meridian . . . .

The Surveyors . . . shall proceed to divide the said territory into townships of six miles square, by lines running due north and south, and others crossing these at right angles . . . .

The plats of the townships respectively, shall be marked by subdivisions into lots of one mile square, or 640 acres, in the same direction as the external lines . . . .

As the PLSS rectangular plan of survey was implemented, it rapidly became apparent that the term *rectangular*, with reference to a plane surface, is a generality that cannot be effectively maintained over a large extent of the surface of the earth.

The lines of the PLSS laid out according to the general plan cannot be “square” when referenced to a plane surface. In fact, the PLSS as implemented is *orthogonal*, with reference to an ellipsoid surface. The lines of the PLSS laid out can be “square,” at right angles, with reference to an ellipsoid surface.

## Measurement

### Basis of Distance

**2-2.** The distance reported is the horizontal measurement at the mean ground elevation for the line above sea level. Historically, distances have been measured on the ground surface, either horizontally or on the slope with vertical angle reduction to horizontal equivalent. The use of a different basis will not be undertaken unless absolutely necessary and will be thoroughly documented in the survey record.

### Basis of Direction

**2-3.** The direction of each line of the public land surveys is determined with reference to the true meridian as defined by the axis of the earth’s rotation. The true meridian is a line along a meridian of longitude. Historically, determination of the true meridian has been based upon direct astronomic observation at the point of record and, thus, an astronomic meridian. The value of the angular difference between the astronomic and geodetic direction, caused by the deflection of the vertical, relates the astronomic meridian to the geodetic meridian, as properly aligned with the axis of the earth’s rotation. This is covered in greater detail in section 2-27.

## Methods of Measurement

**2-4.** The primary goal of any measurement method is to determine the relative direction and length of the line between specific points, monuments, and other evidence of the survey. It is equally important to report the measurements properly once a line is measured. All measurements must be reduced and placed into a common reference system that is well defined, understandable, and, more importantly, consistent with the historical record.

The direction of lines of the PLSS has been determined with a variety of instruments. Historically, these include the magnetic needle, solar compass, transit with solar attachment, and direct altitude or hour angle observations on the Sun, Polaris, or other stars. The use of direct astronomical observations to determine direction is effective and still used. Only the use of the needle compass is unequivocally prohibited. Other valid methods for determining direction of lines include gyroscopic instruments, satellite receivers, orientation from the National Spatial Reference System (NSRS), and identifiable lines between monuments of adjoining official surveys.

**2-5.** The direction of each line of the PLSS is reported in bearings. Bearings are stated in terms of angular measure with reference to the true meridian in degrees, minutes, and seconds or variations thereof. For surveys of the PLSS, the basis for reporting direction is called *mean bearing referenced to the true meridian at the point of record*. There is a small ambiguity in this definition in that there is a slight difference between an astronomic bearing and a geodetic bearing at the same point. This is covered in greater detail in section 2-27.

**2-6.** The primary basis for reporting distances in the PLSS is defined as horizontal measure in chains, based on the U.S. Survey Foot (see section 2-43 for definition), at actual ground elevation. Historically, distances were measured with a chain tool or steel ribbon with lengths of  $\frac{1}{2}$  to 8 chains. The distances measured were made at the ground surface and reduced to horizontal measure. More recently, electronic distance measurements have been used that reduce slope distances to horizontal measure using zenith angles. In both cases, the proper result is obtained when the horizontal distance measurement is reported in the record at the mean ground elevation of the line above sea level.

**2-7.** An exception is surveys in the State of Alaska. Most of the original rectangular surveys in that State are based on protraction diagrams, protractions used for

the surveys created using the North American Datum of 1927 with distances calculated at sea level. The primary basis for reporting distances in Alaska is defined as horizontal measure in chains, based on the U.S. Survey Foot, at zero elevation (sea level). Resurvey distances are also reported on this basis.

**2-8.** Other exceptions exist for PLSS surveys in the continental United States that employ distance measurements based upon grid distances or sea level geodetic distances. The reason for such deviation from the general plan will be stated in the special instructions, and the particular basis for measurement must be clearly stated in the official record.

Previous editions of the Manual detail numerous acceptable methods of survey measurement. The dominant methods of measurement previously described are *direct* in nature, such as chaining distances along the line to be run. Later methods of measuring are more commonly *indirect*, such as the use of satellite technology to “measure” the distance between two points. This latter type of technology derives a three-dimensional vector rigorously defined by a specific coordinate system and horizontal and vertical datum. Another more traditional example of an indirect method of measurement is the use of an electronic distance meter and theodolite.

Using the equipment and direct methods of measurement cited in previous Manuals, a surveyor could both gather and report measured data accurately and in the proper basis. For instance, a properly adjusted solar compass or solar transit determined the true meridian at each instrument setup. Matched with traditional chaining, a line of constant bearing can be run by instrumental orientation without any special reduction of the survey data.

Equipment and methods that rely on indirect methods of measurement do not necessarily report measured values directly in the proper basis. It is important that the surveyor understand the difference and know how to derive and properly report measured data for inclusion in official records.

## The Geodesy of Large-Scale Cadastral Surveys

### Public Land Survey System Datum

**2-9.** The reference system by which measurements of the PLSS are reported is called the PLSS datum. The



geodetic realities of the system require some discussion of the geometric and geodetic realities that are imposed upon defining the PLSS datum.

A datum is the reference system by which the measurements of a survey system are reported. A datum can be complex and rigorously defined, such as the North American Datum of 1983 (NAD 83), or it can be less comprehensive. In PLSS surveying, it is important to gain an understanding of the basis in which measurements are made and reported.

The PLSS is continental in scope. One purpose of the PLSS is to survey large areas of land expeditiously. A key concept is that the system is to be laid out and reported according to “the mean bearing referenced to the true meridian at the point of record.” This requirement places specific constraints on the survey methods employed to properly layout and resurvey such a system.

**2-10.** The PLSS datum is comprised of meridional boundaries that converge toward the poles and latitudinal boundaries, similar to pure latitudinal arcs. Lines and most elements of the PLSS are defined in a geodetic sense. Most boundaries are lines of constant bearing measured at ground elevation.

Simple plane methods are not necessarily suitable for large-scale surveys. A large-scale cadastral survey is one in which the distinction between plane and geodetic computational methods is significant, and it becomes necessary to deal with the geodetic aspects of the survey.

For small-scale surveys, the difference between a geodetic system and a plane system is insignificant. Historically, many cadastral surveys are a mix of astronomical, geodetic, and plane methods. In a retracement, the surveyor must be able to distinguish between the methods used and discern their effect upon the reestablishment of the lines and corners of the prior survey.

### True Meridian at the Point of Record

**2-11.** The basis for reporting direction is called true mean bearing. Stated in terms of angular measure referred to true meridian north, it is referenced to the true meridian at the point of record. In practical application of the concept, the point of record for determining the bearing of a line can be said to be the meridian at the midpoint of the line of sight between the end points.

For lines of any east-west extent, the true meridians passing through each end point of the line are not

parallel; reference meridians are not parallel but converge towards the pole. This is a basis of bearing that is not orthogonal with reference to a plane surface.

**2-12.** The direction of a line can be described by a forward bearing based on the meridian at the beginning point or by a back bearing based on the meridian at the end point. The value prescribed for use in the PLSS is the mean of the two. The difference between the forward and back bearings ( $\pm 180$  degrees) is the angle of convergence of the meridians through the end points of the line.

### Line of Constant Bearing

**2-13.** By statute, in the PLSS datum, the term “straight line” is used when describing a line of constant bearing. The term has a different meaning from that used in geodesy, where a straight line corresponds approximately to a line of sight or a geodesic.

Circles of latitude are often called parallels. A parallel of latitude is an east-west line. Such a line crosses each meridian at  $90^\circ$  or right angles. A parallel is a basic example of a line of constant bearing because it crosses each meridian at the same angle (line 3, figure 2-1).

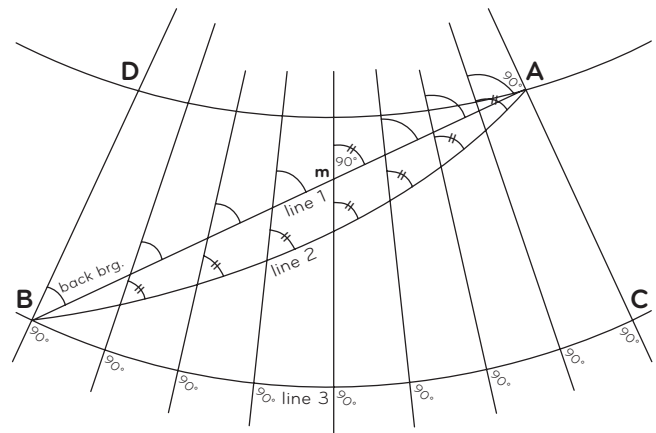


Figure 2-1. Lines on exaggerated converging meridians.

Most lines in the PLSS are intended to be surveyed as lines of constant bearing. This is a direct result of the requirement that the lines be run “according to the true meridian,” thereby crossing each meridian at the same angle (lines 2 and 3, figure 2-1). Other terms used for such lines are rhumb lines, small circles, or loxodromes. Parallels of latitude are sometimes used as boundaries between countries, States, or counties. For example, a portion of the 49<sup>th</sup> parallel was intended to be the



boundary between the United States and Canada from western Minnesota to the State of Washington.

**2-14.** The base lines and standard parallels of the rectangular system are established on the true parallel of latitude; the random latitudinal township boundary lines are also projected on the same curve. Other examples of lines described as lines of constant bearing include section lines, subdivision-of-section lines, and many grant and reservation lines.

Two points at a distance of 20 chains apart on the same parallel of latitude may be said to define the direction of the curve at either point, without appreciable error. However, the projection of a line of sight so defined in either direction, easterly or westerly, would describe a great circle of the earth gradually departing southerly from the true parallel. The rate of departure is a function of the latitude on the earth's surface.

### Line of Sight

**2-15.** Some boundaries of the PLSS are defined by a "line of sight." This line can be defined as the shortest distance between two points. Many conventional surveying instruments make measurements along the line of sight (line 1, figure 2-1).

This line of sight is a line of constantly changing bearing. The only exceptions are meridional lines and the equator. Such a line can be described by a plane intersecting the earth's irregular surface that passes through the earth's center and both end points of the line. Such a line is traditionally called a great circle. For practical considerations, in the PLSS datum, a line of sight is exemplified by the great circle, the shortest line along the earth's surface between two specific end points having no angular deflections along its course.

Because of the convergence of meridians and the requirement to use the true meridian as the basis for the direction of lines, lines not along a meridian are run on constant bearing in order to intersect meridians at the same angle. A line of sight line passes each meridian at a different angle and hence is a line of constantly changing bearing; in other words, it is not a straight line. The bearing of such line is the bearing at the midpoint (point m, line 1, figure 2-1).

**2-16.** Some boundaries within the PLSS are defined as line of sight. The originating documents describing the boundary must be studied to determine whether the line between corners was intended to be a line of sight or

line of constant bearing. A private land grant boundary described as running from one physical monument or feature to another may be by line of sight. Other examples of boundaries defined as line of sight include specifically described portions of some administrative or reservation boundaries, the south boundary of California (with Mexico), and the diagonal boundary between California and Nevada. Such a line, if reported in the PLSS datum, would have different bearings between each corner point on the line.

### Curvature

**2-17.** By basic law, and the Manual requirements, the historical methods and instruments used to lay out the PLSS determine the bearing at frequent intervals with reference to converging meridians. Thus, the direct survey methods and instruments used produced boundary lines run at a constant bearing and adjusted for curvature as part of running the line. In other words, the true line between two end points is precisely such a line of constant bearing and is laid out inherently by direct methods and instruments. The distance chained was measured along the same curve, and the resultant measurement is that of the latitudinal arc distance measured at ground elevation between two points.

**2-18.** If a line is other than a meridian, its direction has an increment of curvature. This refers to the angular difference in the direction of the true meridians through each end point. The amount of curvature of PLSS lines is dependent on the project latitude, given that curvature increases towards the pole.

To visualize this type of line, refer to figure 2-1, which illustrates an exaggerated model of this bearing system with meridians converging towards the north. Line 1 is a line of sight between points A and B. Line 1 is also a line of constantly changing bearing, the chord of the line, a great circle of the earth, and intersects the meridian at different angles. The angle with each meridian is the bearing of line 1 at that point. The bearing at the midpoint of line 1 is the mean bearing.

The latitudinal difference between points on line 1 and line 2 lying on the same meridian is the adjustment for curvature. For resurveys of high-value land and resources over large areas, the adjustment for curvature could be significant and therefore necessary. For original surveys, the adjustment for curvature will be made where significant. All computations will be based upon principles of curvature.

Often referred to as the correction or adjustment for curvature, the effect can be very large at higher latitudes. For example:

At latitude 45° N., it is 52" (seconds) per mile of departure. The adjustment for curvature, at the midpoint of a parallel of latitude line 1 mile in length, at latitude 45° is 0.3 lks. dist.

For latitude 70° N., it is 2' (minutes) 23" (seconds) per mile of departure. The adjustment for curvature, at the midpoint of a parallel of latitude line 1 mile in length, at latitude 70° is 0.7 lks. dist.

### Convergency of Meridians

**2-19.** The linear amount of the convergency of two meridians is a function of their distance apart, the length of the meridian between two reference parallels, the latitude, and the spheroidal or ellipsoidal form of the earth's surface.

The following equation is convenient for the analytical computation of the linear amount of the convergency on the parallel, of two meridians any distance apart, and any length. The correction for convergency in any closed figure is proportional to the area and may be computed from an equivalent rectangular area.

Curvature and convergency can be computed as follows:

$e$  = Factor of eccentricity

$$e = \sqrt{1 - \frac{b^2}{a^2}}$$

Using constants for the Clarke Spheroid of 1866 as an example, then:

$a$  = 6378206.4 meters Ellipsoid semi-major axis

$b$  = 6356583.8 meters Ellipsoid semi-minor axis

Then we find:

$R_p$  = Radius of parallel at base latitude (same units as  $a$ ).

$$R_p = \frac{a}{\tan(\Phi) \sqrt{1 - e^2 \sin^2(\Phi)}}$$

Note that:

$C$  = Curvature in degrees for difference in departure " $m_\lambda$ ".

$$C = (180^\circ/\pi) (m_\lambda/R_p)$$

Finally, given a cardinal figure with the dimensions:

$m_\lambda$  = Measurement along the parallel.

$m_\phi$  = Measurement along the meridian.

$dm_\lambda$  = Linear convergency of meridians.

The formula for computation of the linear convergency of meridians  $dm_\lambda$  is:

$$dm_\lambda = \frac{m_\lambda m_\phi}{R_p}$$

The results are in the same units as the arguments, where the units for all arguments are the same.

### Lengths of Arcs of the Earth's Surface

**2-20.** All computations involving a difference of latitude for a given measurement along a meridian or the converse calculation, or other computations involving a difference of longitude for a given measurement along a parallel, require the computation and reporting of the distance as a latitudinal arc length.

Distance measurements are reduced to horizontal and reported at the mean elevation of the line above sea level. As defined within the framework of a geoid model, this would be analogous to a horizontal line reported at the mean orthometric height of a line. The length of a line as reported in the PLSS datum reflects the degree or increment of curvature applied to the line.

### Geometric Effects and Apparent Misclosure

**2-21.** As stated earlier, the basis of bearing for the PLSS is not rectangular. As a result, the use of plane survey computations to lay out or evaluate PLSS surveys requires special knowledge of how to properly interpret and apply the results. Attempting to use plane computational methods creates a geometric effect called the "apparent misclosure due to meridional convergence." In the PLSS datum, if all measurements for a survey

are perfect for any unit, the survey will appear to misclose when the closure is computed using a plane coordinate system. The effect of this “apparent misclosure” increases with latitude. This apparent misclosure is in departure only. For example:

The unit bounded in figure 2-1 by points A, C, B, and D, which overlays the converging meridians is a “cardinal square.” The sides bear cardinal south, west, north, and east by true mean bearings. If the east, south, and west lines were section exteriors and were 80.00 chains distance in length, it is apparent from the exaggerated illustration that the north boundary must be shorter than 80.00 chains distance due to the convergency of the meridians.

Using plane computational methods for a square mile at a mean latitude of  $40^{\circ}$  N., the north line would be 1.69 links shorter in distance than the south line due to the convergence of the meridians defining its east and west sides; at  $70^{\circ}$  N., the north line would be 5.53 links shorter in distance than the south line.

This apparent misclosure is also a function of the area of the figure. The effect of convergency for larger or irregular parcels can be computed as a ratio of the value determined for a single section at the same mean latitude and that of the area enclosed (figure 2-2).

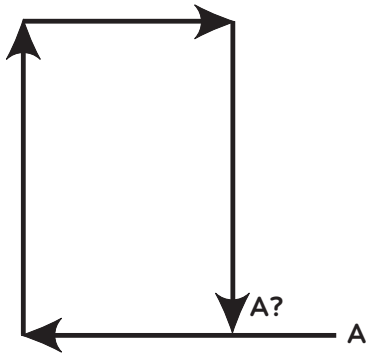


Figure 2-2. Apparent misclosure due to convergency of the meridians.

Another result of applying the use of plane computations in the PLSS datum is that each leg traversed through a single point produces a different coordinate value for the same point based on the differing paths traversed. This geometric effect is a result of both error propagation and the application of meridional convergence to the area traversed.

**2-22.** Using plane computational techniques within the PLSS creates problems due to the orthogonal nature of

basic trigonometric functions. Geodetic computations or the use of geodetic projections eliminate many problems and computational aberrations. To properly use these projections, many factors must be addressed, such as proper conversion to and from the true meridian, to and from mean bearings, and between ground horizontal distances and grid or sea level distances. To properly use geodetic computations, the correction between mean, forward and back bearings, and the elevation of the lines must be considered.

An examination of any modern cadastral survey plat will illustrate that all the sections appear to misclose if computed with plane methods. This is in part due to the apparent misclosure and it should be noted that this is not a true misclosure. While the precision of reported bearings and distances on plats can have a small effect on the result, a value for convergency can be computed and applied to the closure computation to determine the true misclosure for the section considered.

### Area

**2-23.** The areas of closed figures are computed at mean ground elevations. A commonly used automated method for area computation, the “double meridian distance” method, is discussed in detail in section 9-69. This adjustment is based upon the record data. It is not necessary to attempt to correct the figure closure for apparent misclosure due to convergence of the meridians. The closing error of the figure is eliminated or balanced by a compass rule adjustment prior to any area calculations.

Other geodetic computational methods found in textbooks can produce similarly reliable results.

**2-24.** When using projected grid coordinates for area computations, application of scale and elevation factors must be applied to derive proper acreages. The area of a regular section surveyed at a latitude of  $44^{\circ} 25'$  N. and a mean elevation of 6000 feet yields varying results for area. For example:

Using plane computations:

Plane area = 6395.7317 square chains

Plane area = 639.5732 acres

Scaled area at sea level:

Scaled area = 6396.3250 square chains

Scaled area = 639.6325 acres

Scaled area at 6000.00 feet elevation:

Scaled area = 6400.0001 square chains

Scaled area = 640.0000 acres

As shown above, when using grid coordinate projections, the surveyor must calculate area scaled at the mean elevation of a closed figure to report the correct acreage of 640 acres.

### Parallel Lines of the PLSS

**2-25.** In the plan of subdivision of townships, the meridional section lines are established parallel to the east boundary or other governing line. This is necessary to produce as many regular legal subdivisions as possible. This necessitates a slight correction on account of the angular convergency of meridians. Hence, parallel lines of the PLSS mean two lines a constant distance apart.

In the PLSS, parallel lines that are not true east and west will have different bearings. Meridional section lines west of the governing line are deflected to the left of the bearing of the governing line. Meridional section lines east of a governing boundary are given the same amount of correction for bearing but the deflection is made to the right. The correction is equal to the curvature at the mean latitude of the township per mile from the governing line.

The specimen original survey plat, appendix I, demonstrates this concept. The south boundary of the township shows the latitude of the southeast corner of the township. At this latitude, the deflection of each meridional section line is rounded to 1' northwest per mile from the governing east boundary of the township. The curvature applied per mile of line at this latitude is approximately 53" per mile. The deflection is to the left of the governing line.

### Elevation

**2-26.** The distances in almost all PLSS surveys have either been measured horizontally at the ground surface or reduced to horizontal ground distances. Generally PLSS distance measurements are not reduced to any other elevation or surface. Because of this, the elevation (or height above or below mean sea level) of the actual record lines can become relevant in a computation. See the exception for surveys in the State of Alaska, section 2-7.

For example, if the north boundary of a township varies 3000 feet in elevation, care must be taken in the method

used to proportion lost corners along it. This is not an issue when proportioning using a retracement traverse run with traditional methods. However, a question could arise if the retracement measurements are made in a system that has been reduced to a grid or to a sea level basis.

Elevation has increasing computational relevance as the use of satellite-based measurements and rigorously defined coordinate systems and geodetic coordinate projections achieve common use.

### Deflection of the Vertical

**2-27.** There is a slight difference between the astronomic meridian and the geodetic meridian at a given point. This difference is referred to as the Laplace correction and is a result of the difference in direction of the local gravity vector, the normal to the geoid, and the normal to the reference ellipsoid. This causal factor is known as the “deflection of the vertical” or “deflection of the plumb.” As measurement techniques have evolved and earth centered geodetic datums have come into use, this difference is now readily available, whereas in the past it was difficult to obtain. The historical practice of using an astronomic meridian versus the current capability to obtain a geodetic value can create a potential ambiguity that must be resolved in certain cases.

Before full publication of NAD 83, it was generally impractical to observe, determine, or effectively use the Laplace correction. In addition, the basic accuracies required in most surveys make such corrections inconsequential.

**2-28.** The use of global geodetic measurement technology and execution of some large-scale surveys may require accounting for the Laplace correction. In particular, surveys that mix astronomic observations with geodetic measurements of long baselines derived from the geodetic meridian may require an evaluation of the difference. As a general rule, if direction measurement methods are mixed, the value of the local deflection will be obtained. If the difference is significant, a correction will be applied to the astronomic observations to place them on the same basis as the geodetic values. In any case, the method used to determine bearing in the survey must be clearly stated in the field note record. It should be emphasized that in most cases this factor is very small and generally of no concern.

# Coordinate Systems and Projections

## Geodetic Reference Systems

**2-29.** The National Geodetic Survey (NGS) defines and manages the NSRS throughout the United States. The NGS provides the cadastral surveyor with a consistent national coordinate system that defines latitude, longitude, height, scale, gravity, and orientation for the Nation. The NSRS is dynamic and subject to refinement.

In general terms, datum and reference ellipsoids are not cited here because different datums of North America produce virtually identical results when reducing the length and direction of a line. This is, of course, dependent on the precision or number of significant figures used when reporting measurements.

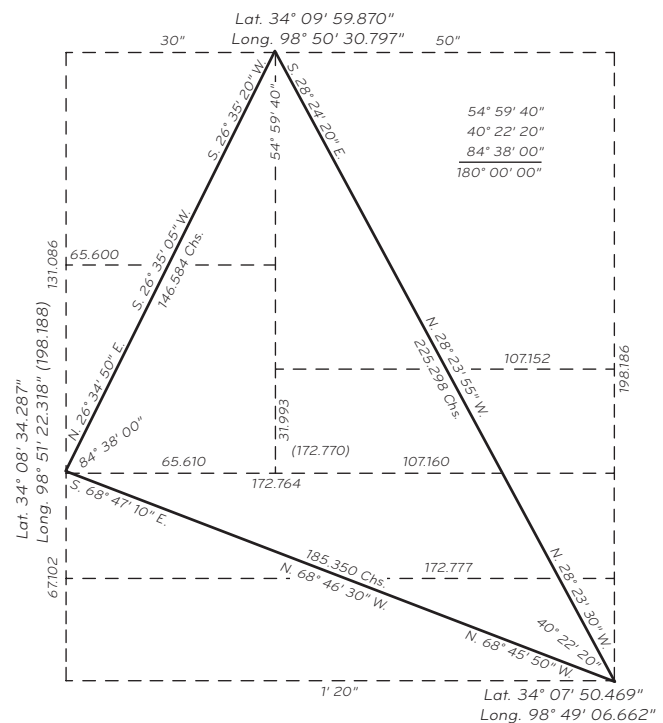
Cadastral surveyors should use automated computational systems as well as geographic and projected grid coordinate systems oriented directly to the NSRS to conduct official surveys.

## Latitudes and Departures

**2-30.** Prior to the availability of automated computations, cadastral surveyors used local rectangular coordinate systems exclusively for field computations. It is important to understand how to properly derive and use local coordinates systems called “latitudes and departures” because they remain the basis of many specialized computations and adjustments applied to the surveys of the PLSS.

The mean bearing of a line is used to determine the north-south and east-west extent of a line. When a line is reduced to its cardinal equivalents, the result is expressed as two distances with a north-south and an east-west component. These two distances are called latitudinal difference or latitude, and longitudinal difference or departure, respectively. For example, a due west boundary line, which follows a parallel of latitude, has zero north-south (latitudinal) extent. Using either the forward or back bearing to compute a line connecting points along such a parallel would not give a zero latitude result. Therefore, the mean bearing of a line is used to determine the latitudinal or longitudinal extent of the line.

It is useful to remember that the mean bearing of a chord (line of sight) connecting any two points along a PLSS



**Figure 2-3.** Curvature of lines of a large triangle.

rhumb line is the same as the bearing of the rhumb line itself (figure 2-3).

## Geographic Positions

**2-31.** The term “geographic position” is used interchangeably with “geodetic position” and refers to a position, expressed as a latitude and longitude, on the referenced ellipsoid representing the earth.

The spheroid in general use for many years past in the PLSS is Clarke’s Spheroid of 1866. It is defined by the dimension of its equatorial axis and the ratio to this length of the amount it exceeds the polar axis. The spheroid closely approximates the shape the earth would have if the ocean surface were continuous. By this system, any position is defined by its latitude and longitude measured from the intersection of the zero meridian of the Royal Observatory at Greenwich, England, and the equator. Linear measurements made between geodetic positions must be reduced to sea level to check the theoretical distance. In the ordinary cadastral survey this refinement will generally not be necessary.

**2-32.** In the township plats of the rectangular system, it is the practice to give the geographic position of at least two corners as determined from the best available source. Surveyors will tie their work to the NSRS whenever practicable.



Geodetic control has assumed increased importance to the cadastral surveyor with the use of protractors to define parcels of unsurveyed land and with the development of digital land information systems.

The surveyor, after assuring that the points of the survey are correctly positioned, will report the results of field observations and techniques used along with the mathematical uncertainty of the geographic coordinates computed in a manner that it is known and recorded. The coordinate data presented will include the correct datum and adjustment date or epoch of the NSRS control used. The precision with which coordinate data is reported will be commensurate with the accuracy of the field observations taken.

The field observations, techniques, and computational processes will be documented in such a manner that future surveyors can confidently replicate the position of the points of the survey on the face of the earth within a known mathematical uncertainty.

### Grid Coordinate Systems and Coordinates

**2-33.** The local surveyor is often concerned with feet, rather than chains. Townsite surveys, mineral surveys, highway surveys, and surveys for other engineering projects are typically made in feet. By making use of the State Plane Coordinate Systems (SPCS), project engineering computations are simplified. These systems facilitate the creation of a permanent record of coordinate positions, provide a check on the closure of a survey, and include common applications that assist in photogrammetric, route alignment, and right-of-way surveys. The SPCS have also been used in the definition of mineral leasing blocks on the Outer Continental Shelf.

The SPCS are rectangular grids designed to fit the curved shape of the earth to a plane surface with as little distortion as possible. This is accomplished by choosing a limited area and a conformal projection. The State-based plane coordinate systems, with one exception in Alaska, are based on either the Transverse Mercator or the Lambert projection. The reliable use of an SPCS system depends upon accurate geodetic coordinate determinations made relative to the NSRS. This geodetic referencing is a necessary condition for accurately determining usable SPCS grid positions for points in an official survey using plane survey methods.

**2-34.** Care must be taken with the use of the SPCS, however, due to inherent differences between these

systems and the PLSS. The mathematical conversions between field measurements and plane coordinate values, for example, involve many relationships. Sea level factors relate ground distances to sea level or geoid equivalents. Elevation factors relate ground distances to geodetic equivalents on the ellipsoid. Grid scale factors relate ellipsoidal or geodetic distances to an equivalent on the projection, or grid surface. The mapping angle, or convergence angle, relates geodetic north to grid north. Arc to chord, or second-term corrections, relate observed pointings to equivalents on the grid and are relevant to both bearings and angles. The grid bearing is a true bearing only along the central meridian of a given SPCS zone, and a grid distance is not generally a true ground distance. Also, acreage on the grid surface differs from the ground surface acreage used in the PLSS.

With the availability of more efficient computational capabilities, performance of ellipsoidal computations on the geodetic datum can be done directly without the intermediate solution provided by State plane coordinates.

Presumably any point can be reestablished once its coordinates have been determined. However, great care must be exercised to ensure that the original coordinate pairs were produced by a process that is repeatable within a quantifiable accuracy standard. Repeatable coordinates may provide collateral evidence of a corner position, may constitute the best available evidence of a corner position, and, in some cases, may constitute substantial evidence of the position of an obliterated corner.

### Use of Local Survey Measurements

**2-35.** The retracement surveyor must exercise caution regarding the basis of bearings when using local survey records as evidence. Even if the local survey is related to an astronomic observation, the bearings for all lines of the local survey may not be reported in true or mean bearings. Such surveys are often based upon a single astronomic bearing determination, which may be indicated in the “basis of bearing” statement. Generally, these plane surveys are related to the true astronomic meridian only at a single point. Inherently, this methodology cannot report true bearings on other lines if there is any significant east and west extent in the area surveyed.

**2-36.** The surveyor must also verify the coordinate basis used in local survey records. It is common to find local records that appear to use State plane coordinates. If the local survey is in a State plane projection,

distances and bearings must be converted to ground values and true mean bearing values, respectively, for comparison to the record. There are many cases where the local survey appears to be in a projection system, but does not use true State plane coordinates. For example, some local surveys are based on a State plane coordinate value at a single station but without proper reduction of ground distances to grid equivalent. Thus, measurements and everything except the initial coordinate pair in the survey fail to actually be in the State plane system. Other local systems deliberately manipulate the datum in order to obtain a scale factor of 1.0 or ground elevation distances.

### Accuracy of Survey Measurements

**2-37.** Field survey measurements require the most stringent application of accuracy standards. Other cadastral services and products ancillary to the survey process depend on the accuracy of the official records of measurements. For example, the spatial depiction of the PLSS in a digital land information system is a byproduct of the abstraction of data from official survey records.

The required accuracy of survey measurements, if different from the Manual, is stated in the special instructions. Different surveys have different accuracy requirements. Generally speaking, the expectation for accuracy will be consistent with specifications of the survey instruments prescribed to satisfy the purpose of the survey. For instance, if the purpose of a survey requires a technology to deliver accuracies of measured lines within 2 centimeters, an error ellipse of 1 meter would suggest a blunder exists in the survey data.

The most stringent requirement in the evaluation of error is that the analysis of error in a data set first identifies and then excludes any blunders or systematic errors introduced through the improper use of the equipment or improper reduction of data.

### National Spatial Data Infrastructure

**2-38.** The National Spatial Data Infrastructure (NSDI) is defined as the technology, policies, standards, and human resources necessary to acquire, process, store, distribute, and improve utilization of geospatial data. Geospatial data is information that identifies the geographic location and characteristics of natural or constructed features, including cadastral data about boundaries below, on, and above the surface of the earth. This information may be derived from

remote sensing, mapping, and surveying technologies and records. Statistical data will be included in characterizing the spatial reliability of cadastral data at the discretion of the agency collecting and disseminating the information.

The Federal Geographic Data Committee (FGDC) is charged with the responsibility to develop spatial cadastral data content standards for the NSDI. The FGDC standards define the methods for reporting the positional accuracy of geospatial data including cadastral data. The FGDC standards are dynamic and subject to refinement.

### Statistical Analysis of Survey Data

**2-39.** A common method of reporting the spatial reliability or accuracy of data is a byproduct of the statistical analysis of survey data. The error ellipse is the most common and lucid depiction of the positional accuracy of a survey point in a traverse or geodetic network.

Current accuracy standards for the acquisition of field data require cadastral data to conform to positional tolerance standards consistent with FGDC reporting standards. Each official delegated the authority to issue special instructions is responsible to define both the methods and expectation of accuracy for cadastral surveys applying these standards.

### Computations in the PLSS Datum

**2-40.** Examples of computations affected by the geometric and geodetic effects of the PLSS datum include:

- Methods for computing or laying out a line of constant bearing.
- Understanding geodetic survey procedures and proper determination of the true mean bearing.
- Understanding and properly applying procedures for using grid coordinate projections.
- Methods for converting geodetic or grid data to the PLSS datum.
- Specialized computations in the PLSS datum, such as single and double proportion; one, two and three point control; and broken boundary adjustments.

- Attention to elevation, elevation variation, and variation of scale factor.
- Area computation.

### Units of Direction

**2-41.** Bearings are reported to the level of precision consistent with the accuracy requirements of the survey and the overall precision of the measurements. Thus, many plats and field notes indicate bearings to only the nearest minute.

### Units of Distance

**2-42.** The law prescribes the chain as the unit of linear measure for the survey of the public lands. The majority of the PLSS has, in fact, been surveyed and reported in chain units. Diversity in survey needs and special requirements may impose the need for surveys reported in feet or meters. The units required, if other than chains, will be specified in the special instructions and must be clearly stated on the plat and in the field notes.

The chain unit, devised in the 17<sup>th</sup> century by Edmund Gunter, an English astronomer, is so designed that 10 square chains are equivalent to 1 acre. In the English colonial area of the United States, the boundaries of land were usually measured in the chain unit, but lengths of lines were frequently expressed in poles. One pole is equal to 25 links, and 4 poles equal 1 chain. The field notes of some early rectangular surveys in the southern States show the distance in “perches,” equivalent to poles. The term now commonly used for the same distance is the rod. There are some places where distances were recorded in 2 pole (perch) chains, where a full mile contains 160 perches. The retracement surveyor needs to be cautious when retracing such surveys, particularly in proportioning measurements.

**2-43.** The chain unit is defined in terms of the U.S. Survey Foot. The difference between the International Foot, as defined in the International System of Units (Système International or SI), and the U.S. Survey Foot is very small, on the order of 2 parts per million. However, this difference must be recognized when long distances are involved. The difference may also be important when dealing with some plane coordinate projections where values of millions of feet are used computationally or otherwise. Common conversions are shown in table 2-1.

**Table 2-1.** Conversions commonly used in PLSS surveying.

Units of Linear Measure	
1 chain = 100 links	
= 66 feet (U.S. Survey Foot)	
= 4 poles, perches, rods	
1 mile = 80 chains	
= 5,280 feet (U.S. Survey Foot)	
Units of Area	
1 acre = 10 square chains	
= 43,560 square feet (U.S. Survey Foot)	
1 square mile = 640 acres	
Metric Conversions	
<i>U.S. Survey Foot</i>	
1 meter = 39.37 inches (exact)	
1 U.S. Survey Foot = 0.3048006096... meter	
1 link = 0.2011684023... meter	
1 meter = 3.2808333333... U.S. Survey Foot	
1 acre = 0.40468726099... hectare	
<i>International Foot (SI)</i>	
1 inch = 25.4 millimeters (exact)	
1 SI Foot = 0.3048 meter (exact)	
1 meter = 3.2808398950... SI Foot	

Land grants by the French crown were made in arpents. The arpent (*arpen*) is a unit of area, but the side of a square arpent came to be used for linear description. The values given in table 2-2 were employed with considerable uniformity, although differing slightly as to exactness and with certain distinctions as noted.

**Table 2-2.** Conversions for French units of area.

The value in Louisiana, Mississippi, Alabama, and northwestern Florida:
1 arpent = 0.84625 acres (very nearly)
The side of a square arpent = 2.909 chains = 191.994 feet
The value in Arkansas and Missouri:
1 arpent = 0.8507 acres (very nearly)
The side of a square arpent = 2.91667 chains = 192.500 feet

The Spanish crown and the Mexican Government granted lands that were usually described in linear varas. Table 2-3 shows the conversions most often needed.

**Table 2-3.** Conversions for Spanish and Mexican varas to chains and feet.

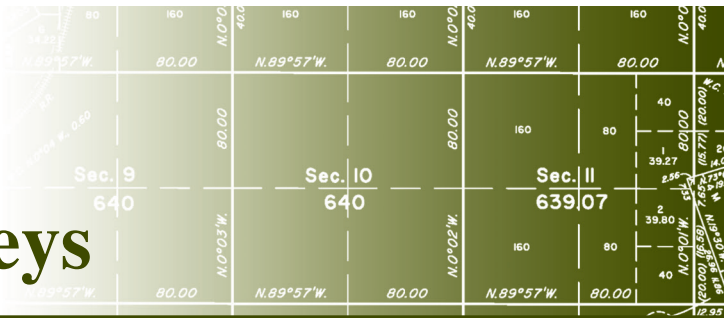
The value in the public domain of the Southwest:	
1 vara	= 32.99312 inches = 4.1658 links
100 varas	= 4.1658 chains = 274.943 feet
The value in Florida:	
1 vara	= 33.372 inches = 4.2136 links
100 varas	= 4.2136 chains = 278.100 feet
The value in Texas:	
1 vara	= 33.333333 inches = 4.2088 links
100 varas	= 4.208754 chains = 277.777 feet
36 varas	= 1.5152 chains = 100.000 feet
1900.8 varas	= 80.00 chains = 5280 feet = 1 mile
75.12 varas square	= 5645.375 square varas = 1 acre

In some cases, slightly different values were employed in the boundary surveys of the French, Spanish, and Mexican land grants in the several U.S. Surveying Districts due to the lack of consistent standards, the disposition to continue the established local practices, and the use of approximate conversion factors. To ascertain the authority for definite equivalents, an examination must be made of the early surveying records and court opinions for the particular district of interest.



## Chapter III

# The System of Rectangular Surveys



## Introduction

**3-1.** The rectangular system of public land surveys over the public domain provides a simple and certain form of land identification and legal description. It has been used continuously since 1785. Although few of the original surveys now being made cover extensive areas, except in the State of Alaska, all facets of the rectangular system occasionally come into use. For this reason, and to make clear the procedures that have been followed in surveying public lands, a complete discussion of the system is included in this Manual.

The field procedures outlined in this chapter include procedures used historically as well as current methods for conducting an original survey. Historically, original surveys were made to create surveys of new areas by extending existing rectangular surveys into unsurveyed lands. This approach differs from the modern practice of using a protraction diagram or predetermined plan of survey so new surveys can be made in areas where they do not necessarily adjoin existing rectangular surveys.

Other procedures discussed in this chapter include creating protraction diagrams, special instructions diagrams where no protraction exists, and modifying approved protraction diagrams. Knowledge of the original field survey procedures used is important when resurveying or retracing an original survey. Many different procedures have evolved and the surveyor will reference the Manual in effect for the time of the survey being retraced.

## General Scheme

**3-2.** Under the rectangular system, the unit of survey is the township of 36 sections. The unit of subdivision is the section of 640 acres. Under the general land laws, the unit of administration is the quarter-quarter section of 40 acres or the lot, either of which is often referred to as the smallest legal subdivision. Under mining and

reclamation laws, the smallest legal subdivision is the quarter-quarter-quarter section of 10 acres. Some special statutes specified even smaller legal subdivisions, e.g., homestead entry surveys within National Forests and mining claim mill sites.

The law provides that (1) the public lands of the United States shall be divided by lines intersecting true north and south lines at right angles so as to form townships 6 miles square; (2) the townships shall be marked with progressive numbers from the beginning; (3) the townships shall be subdivided into 36 sections, each 1 mile square and containing 640 acres as nearly as may be; (4) the sections shall be numbered, respectively, beginning with the number 1 in the northeast section, and proceeding west and east alternately through the township with progressive numbers to and including 36; and (5) a fair plat describing the subdivisions and marks shall be made and recorded at a designated office (Rev. Stat. 2395; 43 U.S.C. 751).

**3-3.** In accordance with the foregoing legal requirements, the public lands are surveyed under the method called the system of rectangular surveys and uses the following procedure:

- (1) The establishment of independent initial points, each to serve as an origin for surveys to be extended in separated localities.
- (2) The survey of principal meridians and base lines, originating at the initial points.
- (3) The establishment of guide meridians initiated at base lines, and of standard parallels initiated at principal meridians, at intervals short enough to maintain a workable adherence to the legal definition of the primary unit, the township 6 miles square.
- (4) The survey of township exteriors within the established framework Townships are numbered

to the north or south commencing with number 1 at the base line, and with range numbers to the east or west beginning with number 1 at the principal meridian.

(5) The subdivision of the townships into 36 sections by running parallel lines through the township from south to north and from east to west at distances of 1 mile. The sections are numbered commencing with number 1 in the northeast section of the township, proceeding thence west to section 6, thence south to section 7, thence east to section 12, and so on, alternately, to number 36 in the southeast section.

**3-4.** By law, (1) the corners marked in public land surveys shall be established as the proper corners of sections, or of the subdivisions of the sections, which they were intended to designate; (2) the boundary lines actually run and marked shall be and remain the proper boundary lines of the sections or subdivisions for which they were intended, and the lengths of these lines as returned shall be held as the true length thereof; and (3) the contents of each section or subdivision of section returned shall be held and considered as containing the exact quantity expressed (Rev. Stat. 2396; 43 U.S.C. 752).

The original corners shall stand as the true corners they were intended to represent, even though not exactly where professional care might have placed them in the first instance. Lost corners must be reestablished in the identical positions they originally occupied. When the positions cannot be determined by existing monuments or other verifying evidence, resort shall be had to the official record (field notes and plat, or field notes on the plat) of the original survey. The law provides that the lengths of the lines, as returned in the official record, shall be held as the true lengths, and the distances between identified corner positions given in the official record constitute proper data from which to determine the position of a lost corner; hence, the rule that lost corners are restored at distances proportionate to the original measurements between identified positions (chapter VII).

Corners established but not marked on the original surveys (sixteenth-section corners, subdivision-of-section corners) will forever remain fixed in position when marked (1) using proper survey procedures, (2) without gross error in measurement, and (3) in accordance with substantial evidence of the position of the controlling corners.

**3-5.** In the sections that follow, the first explanations are with respect to ideal procedure in the rectangular

plan. The plan must be modified in various ways in order to begin new work where the initial and closing lines already established by prior survey do not qualify under the current specifications for rectangularity and closure but cannot be changed now because of the passing of titles based on them. New survey work will avoid the incorporation of the discrepancies of the older lines in the running of new original surveys.

## Initial Points

**3-6.** Since the organization of the system of rectangular surveys, numbered and locally named principal meridians and base lines have been established as listed in table 3-1. These bases and meridians are shown on a special map entitled "Principal Meridians and Base Lines Governing the United States Public Land Surveys" published by the BLM (figure 1-1).

The latitude and longitude coordinates given in table 3-1 are based upon the Greenwich Meridian and the best available information. The horizontal datum used is the North American Datum of 1983 (NAD 83). In some cases the coordinates shown are only an approximate value since many of the initial points were fixed in position by surveys that were largely completed before importance was attached to the matter of accurate coordinates. The geographic coordinates in table 3-1 should not be used in lieu of a field determination, except when an approximate value will satisfy all requirements.

**3-7.** The rectangular system was initiated in the State of Ohio in 1785 from a point on the west boundary of Pennsylvania, on the north bank of the Ohio River, in approximate latitude  $40^{\circ}38'22.051''$  N. and longitude  $80^{\circ}31'08.500''$  W. NAD 83. The State boundary served as the first reference meridian. A number of other reference meridians and bases were employed in Ohio to govern particular areas for purposes of disposal. In its early stages the system was somewhat experimental, and Ohio may well be referred to as the proving ground for the present rectangular system of surveys. The rectangular surveys that have no initial point as an origin of township identification are listed in table 3-2.

## Principal Meridian

**3-8.** A principal meridian is intended to conform to the true meridian, extending north or south, or in both directions, from the initial point as conditions require. Regular quarter-section and section corners

**Table 3-1.** Meridians and Base Lines of the United States Rectangular Surveys

Meridian	Adopted	Governing surveys (wholly or in part) in States of	Initial Points (NAD 83)					
			Latitude N.			Longitude W.		
			°	'	"	°	'	"
Black Hills	1878	South Dakota	43	59	43.760	104	03	18.350
Boise	1867	Idaho	43	22	19.242	116	23	38.708
Chickasaw	1833	Mississippi and Tennessee	35	02	02.000	89	14	49.950
Choctaw	1821	Mississippi	31	52	28.932	90	14	42.408
Cimarron	1881	Oklahoma	36	30	05.266	103	00	08.589
Copper River	1905	Alaska	61	49	02.223	145	18	43.285
Fairbanks	1910	Alaska	64	51	48.503	147	38	34.683
Fifth Principal	1815	Arkansas, Iowa, Minnesota, Missouri, North Dakota, and South Dakota	34	38	44.455	91	03	07.337
First Principal	1819	Ohio and Indiana	40	59	21.760	84	48	11.650
Fourth Principal	1815	Illinois	40	00	51.254	90	27	13.290
Fourth Principal Wisconsin	1831	Minnesota and Wisconsin	42	30	25.900	90	25	36.210
Gila and Salt River	1865	Arizona	33	22	37.827	112	18	21.999
Humboldt	1853	California	40	25	01.985	124	07	13.942
Huntsville	1807	Alabama and Mississippi	34	59	27.050	86	34	16.480
Indian	1870	Oklahoma	34	30	24.496	97	14	50.191
Kateel River Principal	1956	Alaska	65	26	14.088	158	45	40.380
Louisiana	1807	Louisiana and Texas	31	00	31.928	92	24	55.880
Michigan	1815	Michigan and Ohio	42	25	28.751	84	21	52.884
Mount Diablo	1851	California and Nevada	37	52	54.112	121	54	50.958
Navajo	1869	Arizona and New Mexico	35	45	06.775	108	32	14.431
New Mexico Principal	1855	Colorado and New Mexico	34	15	35.946	106	53	14.962
Principal	1867	Montana	45	47	12.824	111	39	35.576
Salt Lake	1855	Utah	40	46	10.269	111	53	28.776
San Bernardino	1852	California and Nevada	34	07	12.997	116	55	51.511
Second Principal	1805	Illinois and Indiana	38	28	09.900	86	27	20.400
Seward Principal	1911	Alaska	60	07	34.933	149	21	33.551
Sixth Principal	1856	Colorado, Kansas, Nebraska, South Dakota, and Wyoming	40	00	07.100	97	22	09.124
St. Helena	1819	Louisiana	30	59	57.000	91	09	36.800
St. Stephens	1805	Alabama and Mississippi	30	59	52.094	88	01	21.067
Tallahassee	1824	Florida	30	26	04.148	84	16	37.559
Third Principal	1805	Illinois	38	28	25.968	89	08	40.269
Uintah Special	1875	Utah	40	25	58.379	109	56	07.418
Umat Principal	1956	Alaska	69	23	28.279	152	00	15.186
Ute Principal	1880	Colorado	39	06	22.727	108	32	01.436
Washington	1803	Mississippi	30	59	57.000	91	09	36.800
Willamette	1851	Oregon and Washington	45	31	10.233	122	44	37.897
Wind River	1875	Wyoming	43	00	40.948	108	48	51.786

**Table 3-2.** Public Land Surveys Having No Initial Point as an Origin for Both Township and Range Numbers

Survey (and year commenced)		Townships numbered	Ranges numbered
Ohio River Survey (Ohio)	1785	North from Ohio River	West from west boundary of Pennsylvania
U.S. Military Survey (Ohio)	1797	North from south boundary of mili- tary grant.	West from west boundary of the Seven Ranges
West of the Great Miami (Ohio)	1798	North from Great Miami River	East from Ohio- Indiana boundary
Ohio River Base (Indiana)	1799	North from Ohio River	From Ohio-Indiana boundary and its projection south
Scioto River Base (Ohio)	1799	North from Scioto River	West from west boundary of Pennsylvania
Muskingum River Survey (Ohio)	1800	1 and 2	10
Between the Miamis, north of Symmes Purchase (Ohio)	1802	East from Great Miami River	North from Ohio River (continu- ing numbers from Symmes Purchases)
Twelve- Mile-Square Reserve (Ohio)	1805	1, 2, 3, and 4	None

are established alternately at intervals of 40 chains, and regular township corners at intervals of 480 chains. Corners designated as meander corners are established at the intersection of the line with meanderable bodies of water.

**3-9.** The survey of the principal meridian and other standard lines (base lines, standard parallels, and guide meridians), require independent verification of the accuracy of measurements made. Typically, verification of measurements will be done: (1) when subdivisional closings are provided in the same assignment with the establishment of the standard line, in which case the closings

furnish a verification of the length; or (2) when the measurements are verified through other independent means such as the statistical analysis of measured data.

If the measurement error of a standard line exceeds 2 links per 80 chains, new measurements are made to reduce the measurement error. If independent tests of the alinement of a standard line indicate that the line has deflected more than 0'50" from the true cardinal course, the source of error will be identified and corrected. These are the maximum discrepancies allowable in new surveys.

## Base Line

**3-10.** The base line is extended east and west from the initial point on a true parallel of latitude. Standard quarter-section and section corners are established alternately at intervals of 40 chains and standard township corners at intervals of 480 chains. Meander corners are established where the line intersects meanderable bodies of water.

**3-11.** The manner of making the measurement of the base line and the accuracy of alinement and measurement are the same as required in the survey of the principal meridian. The determination of the alinement of the true latitudinal curve process is described in the record.

## Protraction Diagrams Plan of Survey

**3-12.** Protraction diagrams have been prepared for substantially all unsurveyed areas in the public domain. Such diagrams are prepared to describe unsurveyed land areas. A protraction diagram is not, and is not intended to be, a substitute for an official survey. Protraction diagrams consist of drawn lines that follow the public land survey system but are not an actual survey. They do not involve a field survey with monumentation and hence no monuments on the ground. They represent the plan for the extension of the rectangular system over unsurveyed lands, following the general scheme as outlined earlier. They are constructed based upon the following rules as far as practicable. For discussion on preparation of protraction diagrams see sections 3-138 through 3-157.

## Standard Parallels

**3-13.** Standard parallels, which have also been called correction lines, are extended east and west from the

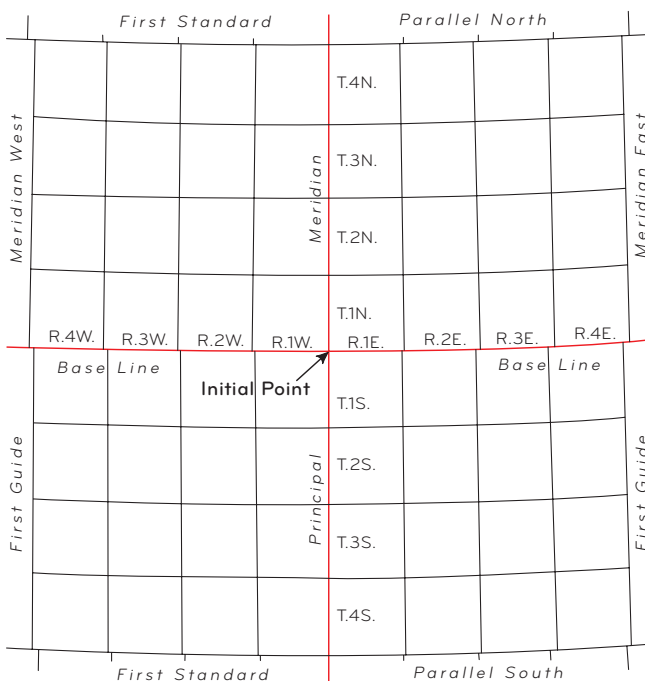


principal meridian, at intervals of 24 miles north and south of the base line, in the manner prescribed for the survey of the base line.

Where standard parallels previously have been placed at intervals of 30 or 36 miles, and present conditions require additional standard lines, an intermediate standard parallel line is established to which a local name may be given, such as “Fifth Auxiliary Standard Parallel North” and run like a regular standard parallel.

## Guide Meridians

**3-14.** Guide meridians are extended north from the base line, or standard parallels, at intervals of 24 miles east and west from the principal meridian, in the manner prescribed for running the principal meridian. The guide meridians terminate at the points of their intersections with the standard parallels. The guide meridian is projected on the true meridian, and the excess or deficiency in measurement is incorporated in the last half mile. At the point of intersection of the guide meridian with the standard parallel, a township corner is established. The corner typically controls one side of a line only, a corner of minimum control. The parallel is retraced between the nearest corners on the standard parallel east and west to determine the alinement, and the distance is measured and recorded to each of the corners (figure 3-1).



**Figure 3-1.** Survey of quadrangles, each embracing 16 townships bounded by standard lines, showing the coordinate system of numbering townships.

**3-15.** When existing conditions require that guide meridians be run south from the base or standard parallel lines, they are initiated at the theoretical point for the intersection of the guide meridian, calculated on the basis of the survey of the line from south to north initiated at the proper standard township corner. At the theoretical point of intersection a township corner is established.

**3-16.** Where guide meridians have been placed at intervals exceeding the distance of 24 miles, and new governing lines are required, a new guide meridian is established, and a local name is assigned, such as “Twelfth Auxiliary Guide Meridian West” or “Grass Valley Guide Meridian.” Auxiliary guide meridians are surveyed in all respects like regular guide meridians.

## Township Exteriors

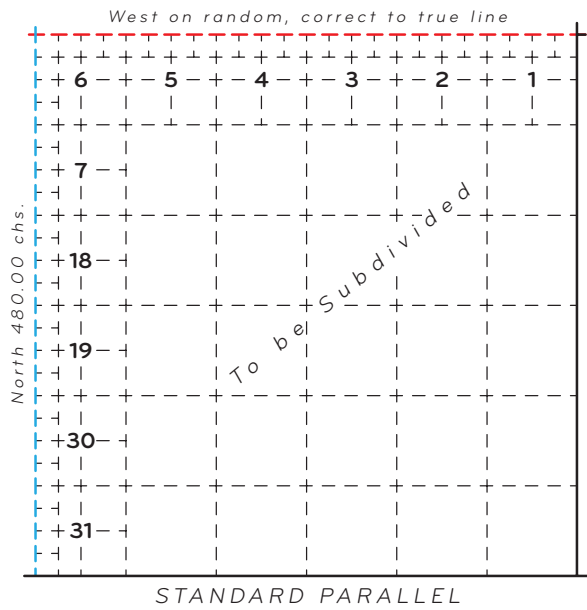
### Regular Order

**3-17.** The south and east boundaries of a township are normally the governing lines of the subdivisional surveys. Defective conditions in previously established exteriors cannot be eliminated where subdivisional lines have been initiated from or closed upon an old boundary, but the errors of former surveys are not incorporated into the new. Where the previously established south and east boundaries cannot on that account be used to govern the subdivision of the adjoining township, other controlling lines known as the sectional correction line and the sectional guide meridian, or the governing section line are employed (figures 3-2 through 3-7).

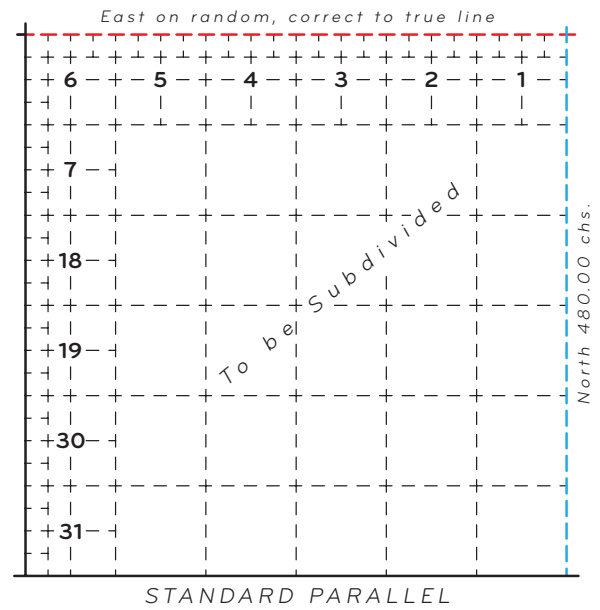
### Meridional Boundaries

**3-18.** Whenever practicable, the township exteriors are surveyed successively through a quadrangle in ranges of townships, beginning with the townships on the south. The meridional township boundaries have precedence in the order of survey and are run from south to north on true meridians. Quarter-section and section corners are established alternately at intervals of 40 chains, and meander corners are established at intersections of the line with meanderable bodies of water. A temporary township corner is set at a distance of 480 chains, pending determination of its final position. The temporary point is then replaced by a permanent corner in proper latitudinal position.

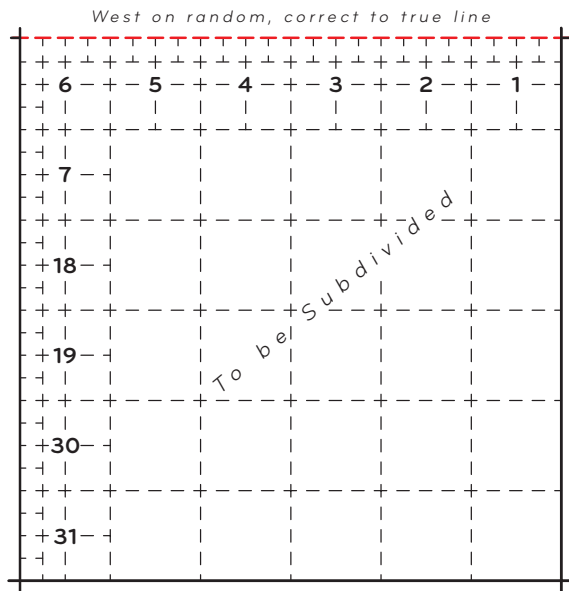
**3-19.** A meridional exterior is terminated at the point of intersection with a standard parallel. The excess or



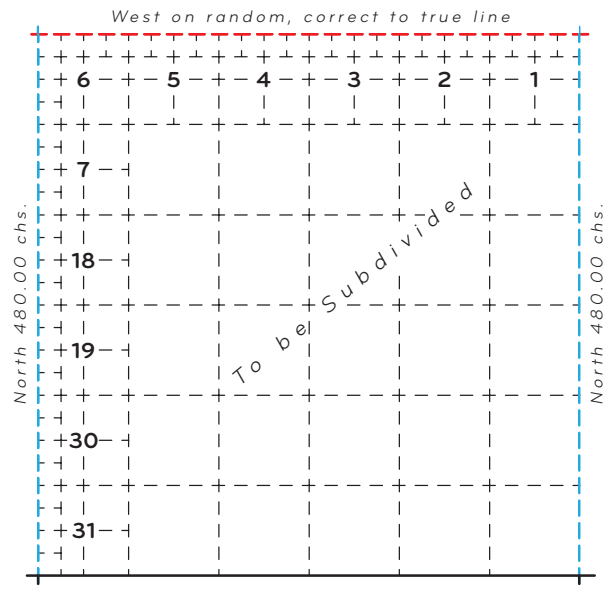
**Figure 3-2.** Regular order of completing exteriors where the south boundary (standard parallel) and east boundary were previously surveyed.



**Figure 3-4.** Regular order of completing exteriors where the south boundary (standard parallel) and west boundary were previously surveyed.



**Figure 3-3.** Regular order of completing exteriors where the south, east, and west boundaries were previously surveyed.



**Figure 3-5.** Regular order of completing exteriors where the south boundary was previously surveyed.

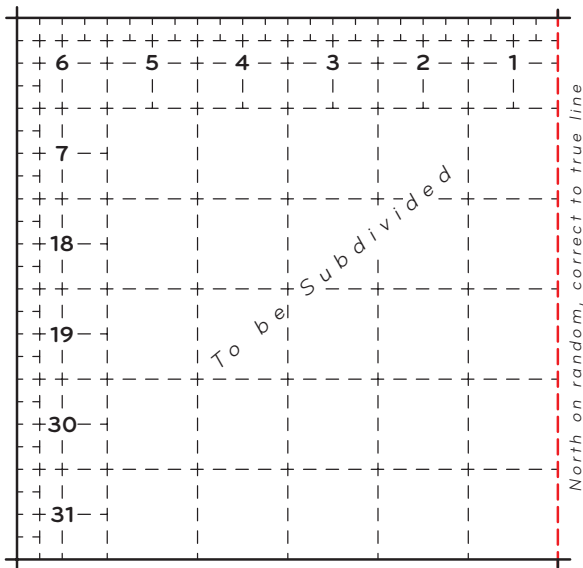
deficiency in measurement is incorporated in the north half mile. A corner is established at the point of intersection. The parallel is retraced between the nearest corners on the standard parallel east and west to determine the alinement, and the distance is measured and recorded to each of the corners.

**3-20.** In order to complete the exteriors of a township it often remains to establish a meridional boundary between previously established township corners. The meridional township boundary is run and, if defective conditions are not encountered, the corners are established from south

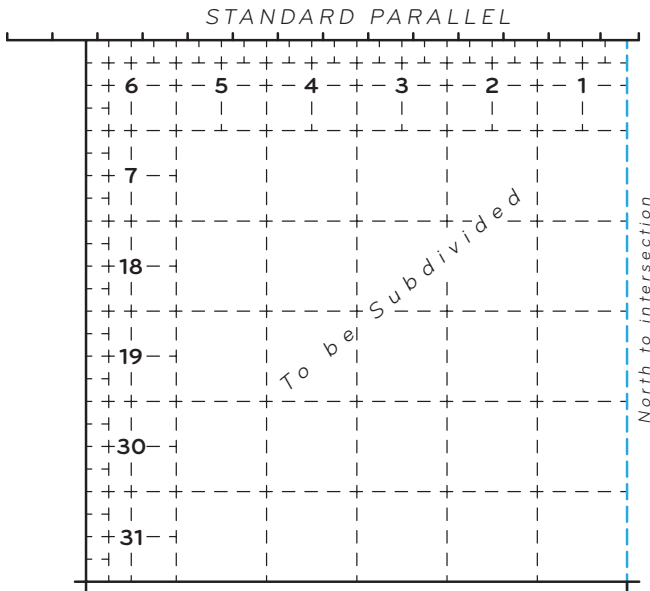
to north on the line connecting the previously established township corners, at intervals of 40 chains and at intersections with meanderable bodies of water, marking the true line. By this procedure, the excess or deficiency in measurement is incorporated in the north half mile, and double sets of corners are avoided.

**Latitudinal Boundaries**

**3-21.** In order to complete the exteriors of a township, and if defective conditions are not encountered, the latitudinal boundary is run connecting the objective



**Figure 3-6.** Regular order of completing exteriors where the north, south, and west boundaries were previously surveyed.



**Figure 3-7.** Regular order of completing exteriors where the north boundary (standard parallel), south boundary, and west boundary were previously surveyed.

township corners. Corners are established from east to west along the latitudinal curve connecting the township corners, at intervals of 40 chains and at intersections with meanderable bodies of water, marking the true line. By this procedure, the excess or deficiency in measurement is incorporated in the west half mile, and double sets of corners are avoided where unnecessary.

**3-22.** When lines are run by the random and true method, the bearing of the true line is calculated from the falling of the random line. The falling is the distance, on the normal, by which a line falls to the right

or left of an objective corner. The temporary points on any random line are replaced by permanent corners on the true line, along the latitudinal curve. The true line is marked, and distances to important items of topography are adjusted to correct the true line measurement.

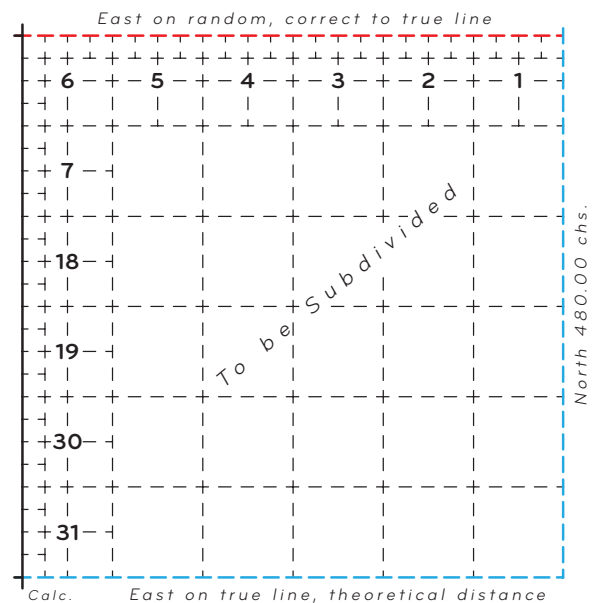
**Official Record of Township Exteriors**

**3-23.** The official record contains a complete record of the manner in which township exteriors have been run and established. The details of the measurement processes may be shown where a special purpose is served.

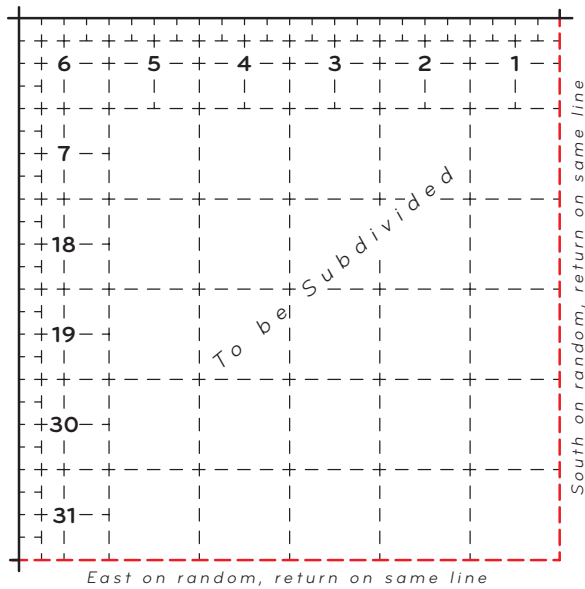
**Irregular Order and Partial Surveys**

**3-24.** Sometimes procedures will be modified and departure made from the ideal when creating protraction diagrams. The departure from the ideal order is specifically outlined by a new protraction diagram or by supplemental special instructions and diagram. Any such departure is always based on the principle of accomplishing the same relation of one township boundary to another as would result from regular establishment under ideal conditions. Some examples are illustrated in figures 3-8 through 3-13.

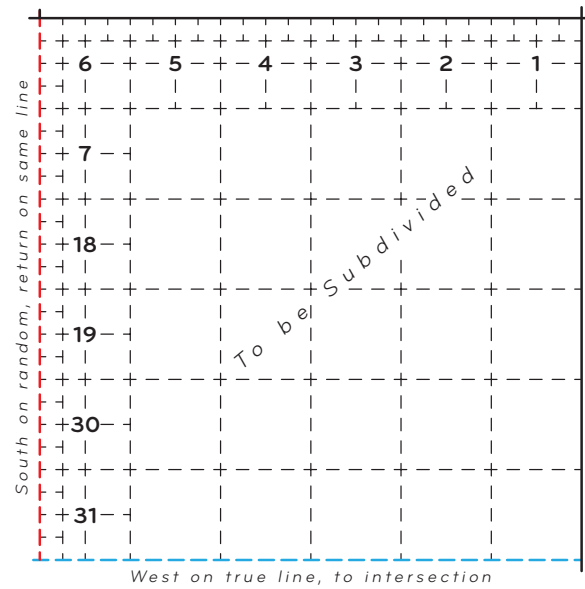
**3-25.** Where it is impracticable to establish the boundaries in full, it may be necessary to run section lines as offsets to township exteriors. Such lines are run either on cardinal courses or parallel to the governing township



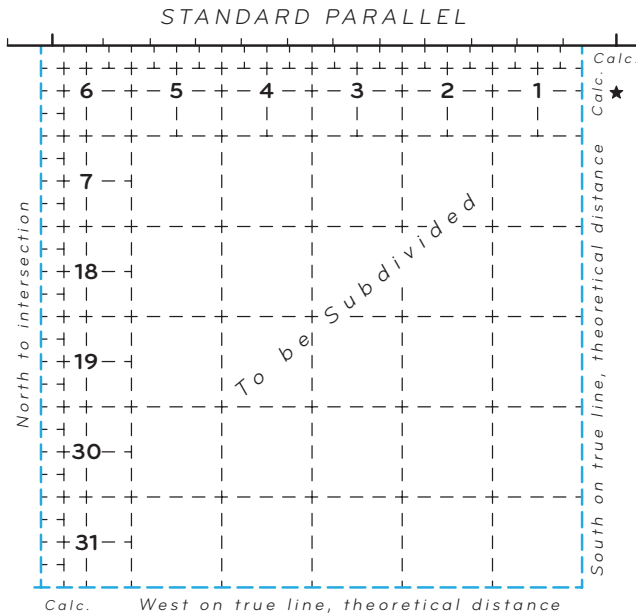
**Figure 3-8.** Exception to the regular order of completing exteriors; only the west boundary was previously surveyed.



**Figure 3-9.** Exception to the regular order of completing exteriors; only the north and west boundaries were previously surveyed.

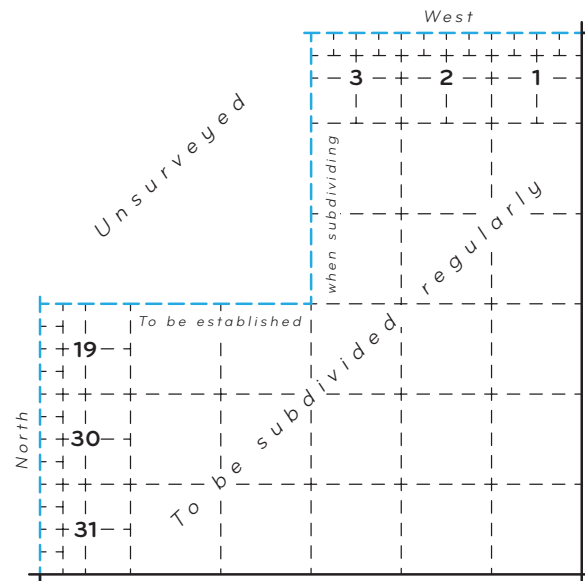


**Figure 3-11.** Exception to the regular order of completing exteriors; only the north and east boundaries were previously surveyed.



★ Exteriors initiated at a theoretical point for a closing corner

**Figure 3-10.** Exception to the regular order of completing exteriors; the only north boundary (standard parallel) was previously surveyed.



**Figure 3-12.** Exception to the regular order of completing exteriors; the south and east boundaries were previously surveyed, but part of the township is unsurveyed.

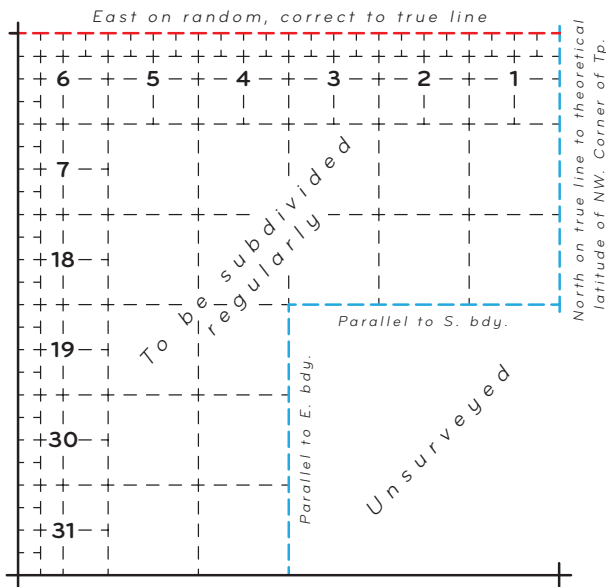
boundaries, and may be established when subdividing, as required.

**3-26.** For townships not monumented in full in the original survey, the spacing of the monumentation does not change the need for meeting all other requirements. The positions of corners are controlled by the monumented corners and the measurements and references provided in the official record. Thus, what is produced in the field will be in true proportion to the figure represented upon the plat.

**Allowable Deviation in Bearing**

**3-27.** It is desirable that the alinement of a new latitudinal boundary (which becomes the governing south boundary of the township to the north) will not depart more than 14' from the true cardinal course. Therefore, the true cardinal course is made the boundary where the alinement would otherwise require a correction exceeding 14' of arc. Where the latitudinal boundary terminates on a new meridional exterior, the temporary township corner is adjusted to the latitude of the





**Figure 3-13.** Exception to regular order of completing exteriors; the south and west boundaries were previously established, but part of the township is unsurveyed.

opposite township corner. But, where both meridional boundaries have been previously surveyed, a township corner is established at the point of intersection of the true cardinal course latitudinal line with the meridional boundary, or its projection to the north or south.

**3-28.** A true cardinal course meridional boundary becomes the true line if the falling plus the correction for parallelism of the meridional subdivisional lines results in calculated bearing (in the northernmost miles of the latter lines) in excess of 14' from cardinal (table 3-3). The bearing of a governing east boundary must, therefore, fall within certain extremes suited to the latitude of the township.

**3-29.** The 14' limit for exteriors applies only to the establishment of new boundaries. A previously established boundary, every part of which is within 21' of cardinal, is not considered defective in alinement. Even in the case of new exteriors, where the surveyor who establishes the line also subdivides the township of which it is the governing boundary, the margin of 14' may be exceeded to a limited extent if the existing conditions favor keeping within the 21' limit in the subdivisional survey. Therefore, the 14' limit facilitates the establishment of all subdivisional lines within the prescribed definite limit of 21' from cardinal (figure 3-14).

### Completion of Partially Surveyed Exteriors

**3-30.** Where the end portions of a township exterior have been previously surveyed and fixed in position by

use, the fractional unsurveyed middle part is completed by establishing a connecting line between the existing corners, regardless of the deviation from cardinal direction. The excess or deficiency in measurement is incorporated as a general rule in the north or west half miles, as the case may be, thereby permitting the subdivisional lines to be extended as usual from south to north or from east to west (figure 3-15).

**3-31.** Where a fractional part of an exterior remains unsurveyed at either end of the line, a connecting line from the previously established terminal corner toward the objective township corner becomes a true line where the calculated bearing of any subdivisional line governed by the exterior comes within 14' from cardinal direction. If this condition cannot be met, or if no objective township corner has been previously established, the partially surveyed exterior is completed on a true cardinal course. In either case, the excess or deficiency in measurement is generally incorporated in the north or west half mile.

### Aliquot Parts in the Rectangular System

**3-32.** Relative to rectangular surveys the square mile, or section, is the unit of subdivision. The regular township includes 36 sections in all, 25 of which are regular sections returned as containing 640 acres each, subdivided into regular "aliquot parts," based on midpoint protraction and intersections. Irregular sections against the north and west boundaries, except section 6, contain regular aliquot parts returned as totaling 480 acres with four additional regular lots returned as containing 40 acres plus or minus the excess or deficiency in measurement in each section. Section 6 contains regular aliquot parts returned as totaling 360 acres with seven additional regular lots, each returned as containing 40 acres plus or minus the excess or deficiency in measurement.

The aforementioned section returned as containing 640 acres is termed "regular" with aliquot part legal subdivisions, such as a half-section, a quarter-section, a half-quarter section, or a quarter-quarter section. The smallest legal subdivision for purposes of disposal under the general land laws is 40 acres unless otherwise specified in a given law. The lots of sections, for purposes of disposal under the public land laws, are termed "legal subdivisions" and are the smallest legal subdivision unit where applicable.

**3-33.** In theory, aliquot parts can be divided ad infinitum. The common practice is to subdivide to a four

**Table 3-3.** Applying corrections for convergency within a township

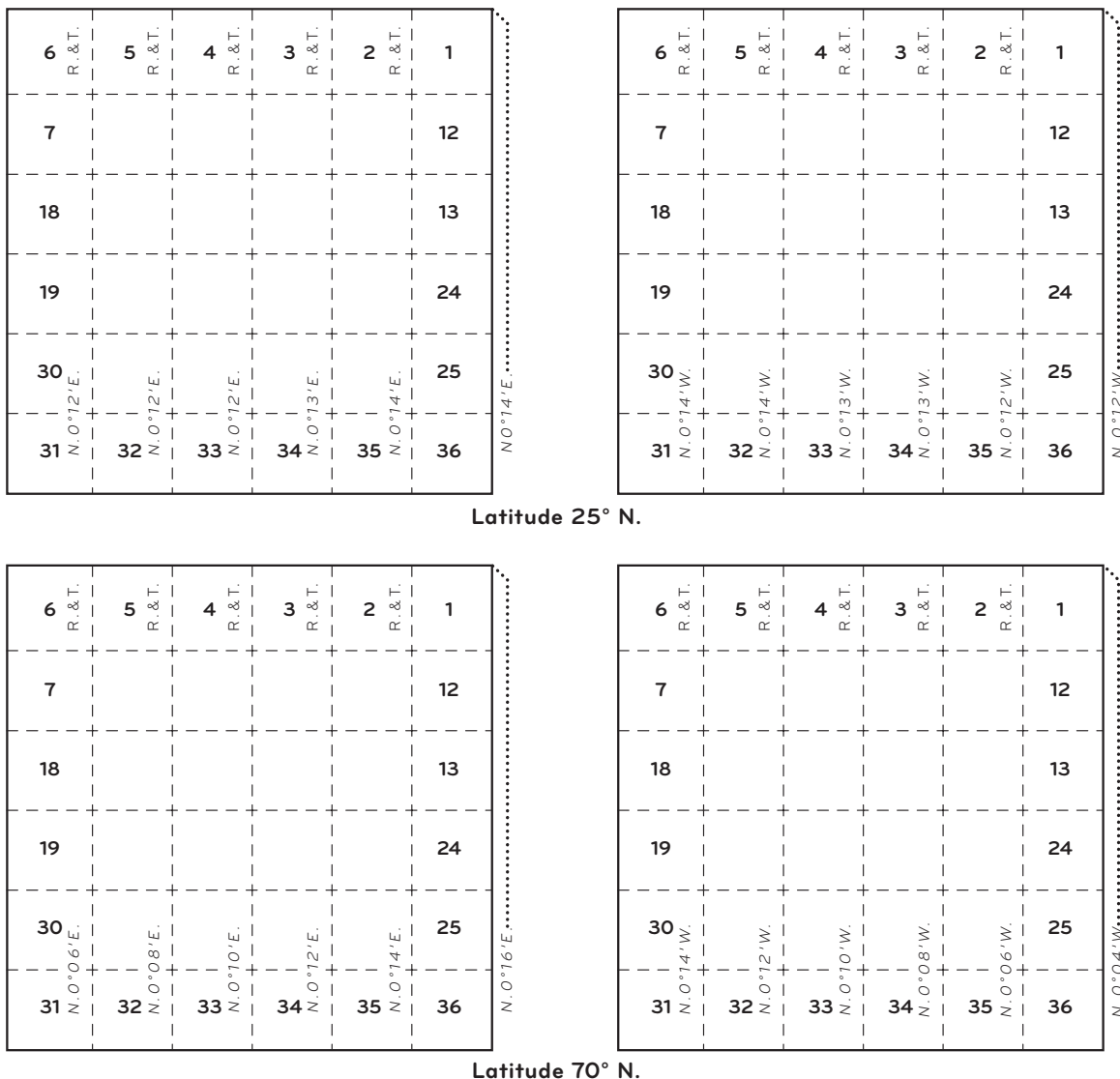
Latitude 25° N.	
1 <sup>st</sup> Mi. Mer. Subdv.	N. 0° 14' E.
Corr. for Conv.	+ 00
E. bdy. may be	N. 0° 14' E.
Latitude 70° N.	
1 <sup>st</sup> Mi. Mer. Subdv.	N. 0° 14' E.
Corr. for Conv.	+ 02
E. bdy. may be	N. 0° 16' E.
5 <sup>th</sup> Mi. Mer. Subdv.	N. 0° 14' W.
Corr. for Conv.	- 10
E. bdy. may be	N. 0° 04' W.

component description. Aliquot parts with five components or more may be platted as lots to avoid complex descriptions subject to error (section 9-90).

**Rectangular Limits**

**3-34.** It is essential to understand the definite relationship between rectangularity as contemplated by law and the unit of subdivision resulting from a survey on the earth's curved surface. The ideal section is allowed to give way to one that is termed "regular" (see section 2-21 for apparent misclosure). The amounts by which a section, or its aliquot parts, may vary from the ideal section and still be considered regular are referred to as the *rectangular limits*:

- (1) For *alinement*, the section's boundaries will not exceed 21' from cardinal in any part, nor will



**Figure 3-14.** The adjustment in the direction of the meridional lines of a subdivisional survey on account of convergency of meridians and also the 14' limit of the rectangular "safety zone."

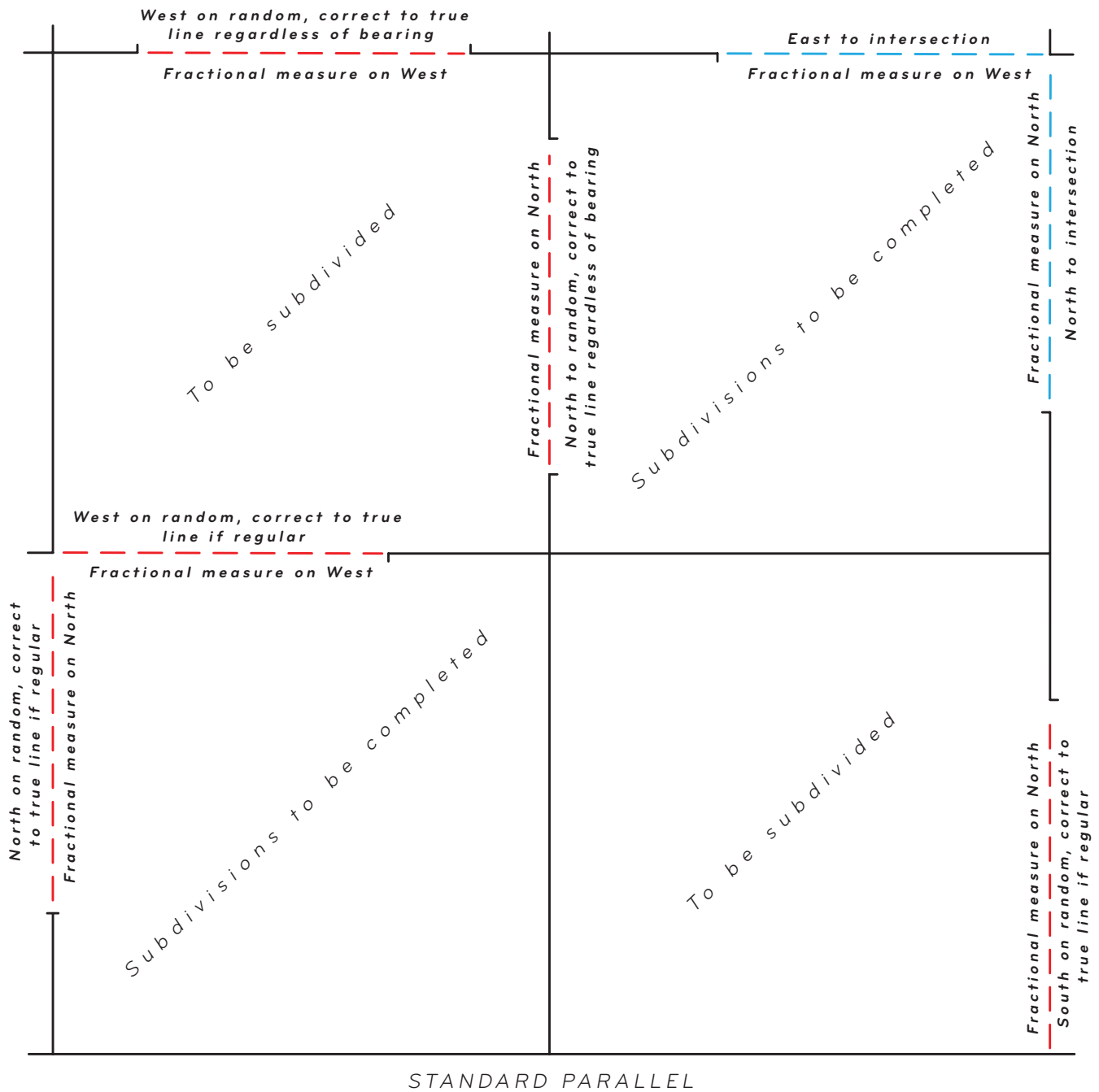


Figure 3-15. Representative cases of incomplete township exteriors showing methods for completion.

the opposite (regular) boundaries of a section vary more than 10'30".

(2) For *measurement*, the distance between regular corners is to be normal according to the plan of survey, with certain allowable adjustments not to exceed 25 links in 40 chains.

Township exteriors, or portions of exteriors, are considered defective when they do not qualify within the above limits. It is also necessary, in

order to subdivide a township regularly, to set a third limit, as follows:

(3) For *position*, the corresponding section corners upon the opposite boundaries of the township are to be so located that they may be connected by true lines that will not deviate more than 21' from cardinal.

**3-35.** A previously established exterior is not defective if the above limits are satisfied. If the rectangular

limits have already been exceeded, or the danger zone is likely to be reached at an early stage in the subdivisional survey, the necessary corrective steps are taken before subdividing.

**3-36.** The rectangular limits should not be confused with the allowable error of closure discussed under sections 3-50 and 3-215. When the allowable error of closure is exceeded, in the township exteriors, generally the rectangular limits cannot be met in the subsequent township subdivision. Typically corrective steps are required wherever the maximum allowable error of closure is exceeded.

The rectangular limits and limits of closure discussed in this chapter pertain to original surveys. They reflect the minimum requirements for original surveys and ensure that rectangularity is maintained and that surveyed lines can be safely incorporated into later new surveys. The desired result is to return a maximum number of regular sections within the township.

### Retracements and Resurveys Before Subdividing

**3-37.** If there is reason to question the accuracy of previously surveyed township exteriors or the condition of the corner monuments, the special instructions should call for the surveyor to reestablish lost corners, remonument dilapidated corner monuments, determine the direction and length of all lines, furnish data needed for the computation of areas of irregular parts, and recommend any improvements indicated for the plan of subdivision.

**3-38.** For townships with protraction diagrams, where rectangular limit requirements can be met, original surveys should follow the plan outlined by the protraction diagram. Where field conditions reveal that the rectangular limit requirements cannot be maintained, and the corners are not fixed in position by use, the protraction diagram should be abandoned and a new plan for survey provided by a new protraction diagram or by supplemental special instructions and diagram.

**3-39.** All resurvey data are embodied in the official record, field notes and plat, or shown upon the plat only of the survey unless the retracement results are in substantial agreement with the record of the original surveys. In the latter case, a statement to the effect is made in the field notes or on the plat, and the original record governs the data placed on the plat.

### Defective Exteriors

**3-40.** Township boundaries already established may be defective in alinement, measurement, or position. A defective boundary not previously closed upon and from which subdivisional lines have not been initiated is obliterated after being superseded by survey of a new boundary and connection of the old with the new monuments. If it is known that a mineral survey, homestead entry survey, small holding claim, right-of-way, reservoir, or other survey has been connected with a corner of an exterior subject to rectification, the fact is stated in the special instruction. In such a case the marks "AM" (signifying "amended monument") are added to the original corner monument, the monument is buried in place, if practicable, and the old corner is connected by course and distance to the new. A record of the connection is placed in the official record together with a full description of the monument and its accessories. Where a special purpose is served, the position of the old monument is shown on the plat of the survey.

**3-41.** If a boundary is defective in measurement or position and is not subject to rectification, the location of the original corners cannot be changed, but the marks on the monuments and the marks upon (or position of) the accessories are appropriately altered to stand only for the sections of the previously established surveys. New corners to control the surveys of the adjoining township are established on the old line at regular distances of 40 and 80 chains. Where new corners are placed on an oblique exterior, whose bearing departs more than 30' from cardinal, they are so located for measurement that the *cardinal* equivalents are 40 and 80 chains.

**3-42.** Where subdivisional lines have been initiated from or closed upon one side of only a portion of a township boundary, the remaining portion may be superseded if it is found to be defective.

**3-43.** The position of the new exteriors, or of corners set on defective township boundaries in the new survey, will be established by an actual rerunning of the lines. Data acquired in surveying subdivisional lines intersecting a defective exterior is not acceptable in lieu of retracement or dependent resurvey.

**3-44.** The south boundary of a township is regularly the governing latitudinal boundary unless defective in alinement. If the boundary is defective in measurement



and not subject to rectification, the original corners are changed to refer only to the sections of the township to the south. New corners of two sections and quarter-section corners of sections of the township to the north are established at regular intervals of 40 chains, counting from the east, and the excess or deficiency in measurement is incorporated in the west half mile. If the south boundary is defective in alinement, a sectional correction line or a governing section line is required. Subdivision of the sections between the defective boundary and the sectional correction line is covered in section 3-112.

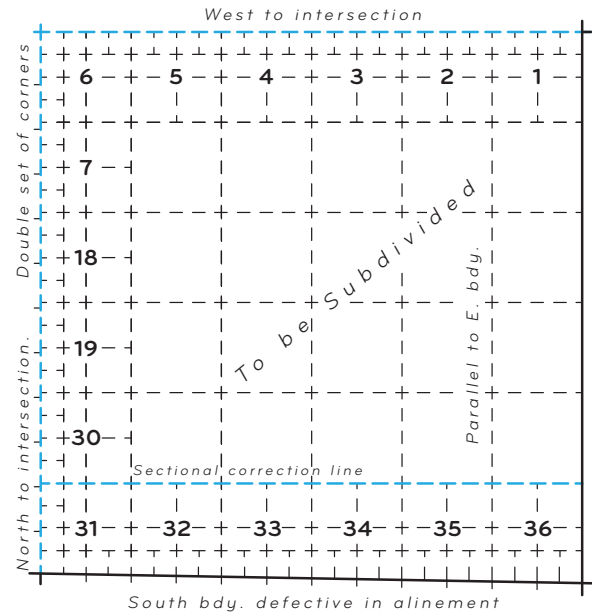
**3-45.** The east boundary of a township is regularly the governing meridional boundary unless defective in alinement. If the boundary is defective in measurement and not subject to rectification, the original corners are changed to refer only to the sections of the township to the east. New corners of two sections and quarter-section corners of the sections of the township to the west are established at regular intervals of 40 chains, counting from the south, and the excess or deficiency in measurement is incorporated in the north half mile. If the east boundary is defective in alinement, a sectional guide meridian or a governing section line is required. Subdivision of the sections between the defective boundary and the sectional guide meridian is covered in section 3-112.

**3-46.** New east and south boundaries of a township become the meridional and latitudinal boundaries of the townships to the east and south respectively. Where doubt exists as to how unsurveyed lines may relate to new lines, the corners are established only for the sections of the townships of which the new lines are the governing boundaries. The corners of the sections upon the opposite side are established at the time of subdivision of the adjoining townships if the original corners are found to be defective in position. If regular connections can be made at that time, the marks on the original monuments are altered to signify corners of maximum control.

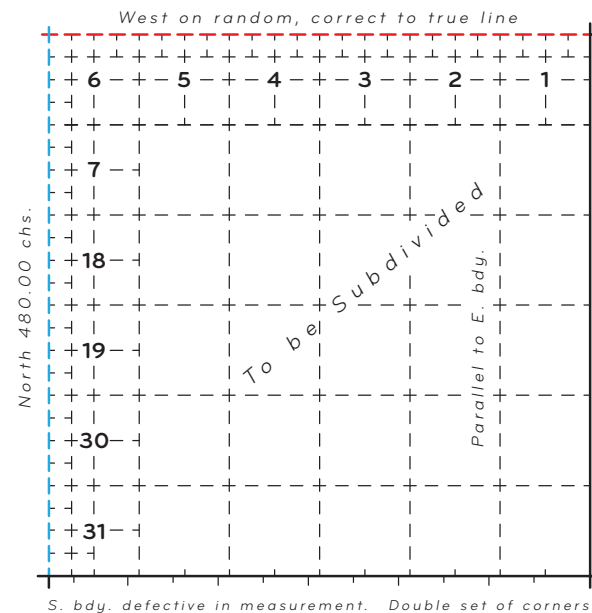
**3-47.** Where the previously established north or west boundaries are defective in measurement or position and subdivisional surveys have been initiated from them, the original corners are changed to refer only to sections to the north or west, respectively. Section corners are established when subdividing. New quarter-section corners are placed on the old line at the mean distances between the new section corners, or at 40 chains from one direction, depending upon the plan of subdivision of the section. Where the previously established north

or west boundaries are defective in alinement but not in measurement or position, no changes are required. The section lines of the township that is being subdivided are connected regularly to the original corners. Excess or deficiency in measurement is incorporated in the north and west half miles.

**3-48.** Figures 3-16 through 3-23 illustrate the guiding principles involved in establishing new governing boundaries where the previously surveyed exteriors



**Figure 3-16.** Rectification of a fixed south boundary defective in alinement.



**Figure 3-17.** Rectification of a fixed south boundary defective in measurement.

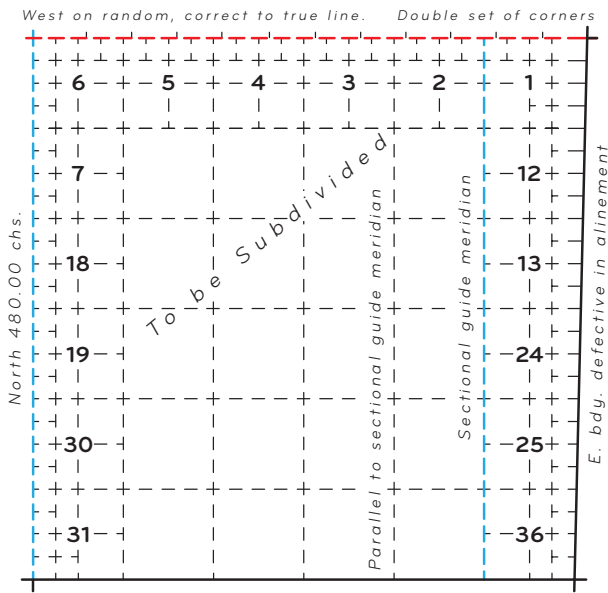


Figure 3-18. Rectification of a fixed east boundary defective in alinement.

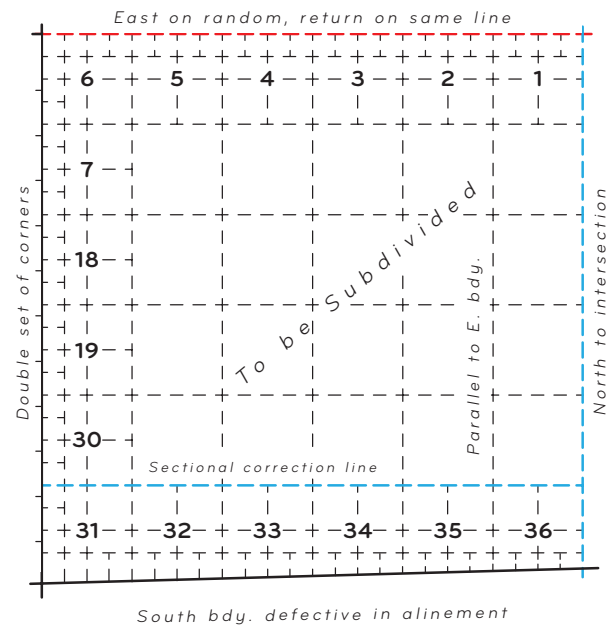


Figure 3-20. Rectification of a south boundary defective in alinement where both the south and west boundaries are fixed in position.

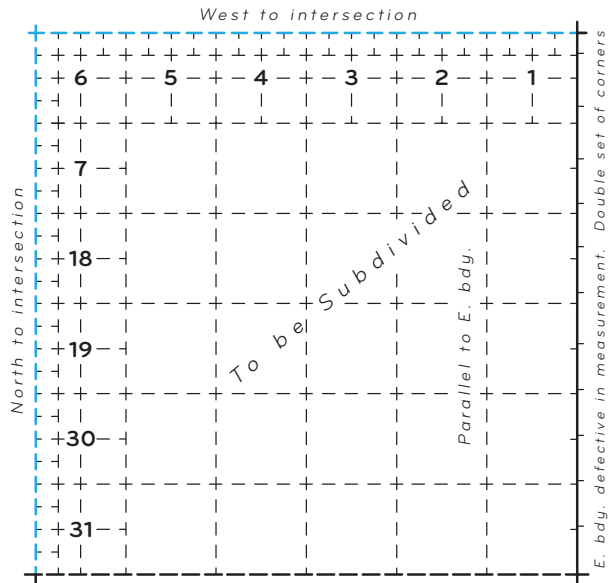


Figure 3-19. Rectification of a fixed east boundary defective in measurement.

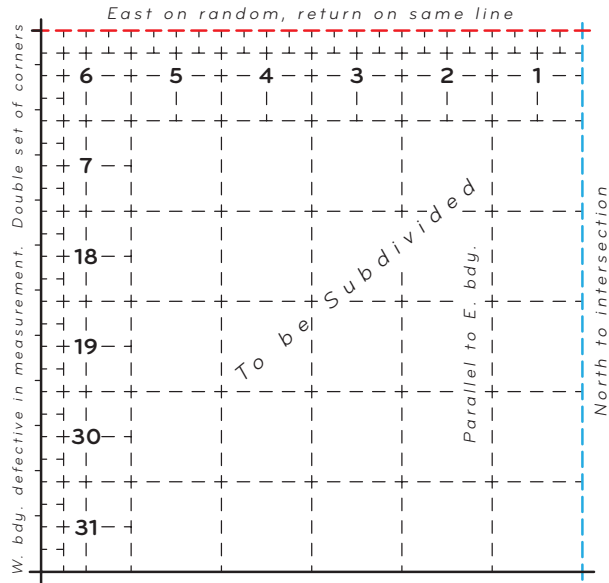


Figure 3-21. Rectification of a west boundary defective in measurement where both the south and west boundaries are fixed in position.

are defective. Each figure illustrates a simple condition affecting one boundary only, and the examples are taken only from the regular order of procedure. Figure 3-24 shows a series of conditions that might occur in the field. Combinations of defective conditions are best analyzed by breaking them down into the several simple defective conditions. The same holds true in the establishment of township exteriors under an irregular order of procedure. Where extraordinary conditions are encountered that cannot be solved in this manner, the surveyor will report

the facts to the proper administrative office, which will issue appropriate instructions.

**3-49.** The rules for completion and rectification of township exteriors are intended to secure the most direct return to normal procedure. The preliminary retracements and resurveys may show that some modification will obtain better results. Approval of the modified plan will be obtained from the proper administrative office. Each case should be treated on its own merits.

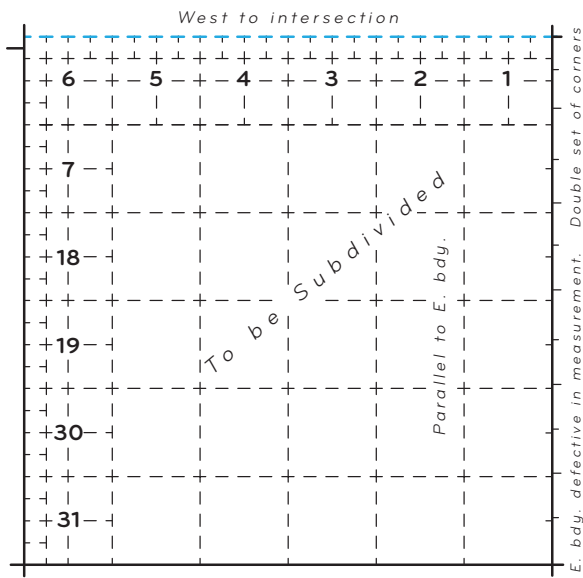


Figure 3-22. Rectification of an east boundary defective in measurement where the east and south boundaries are fixed in position.

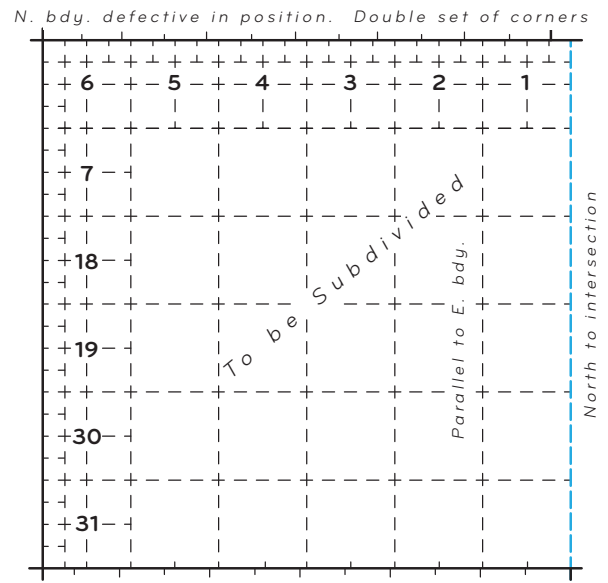


Figure 3-23. Rectification of a south boundary defective in measurement where the south, north, and west boundaries are fixed in position.

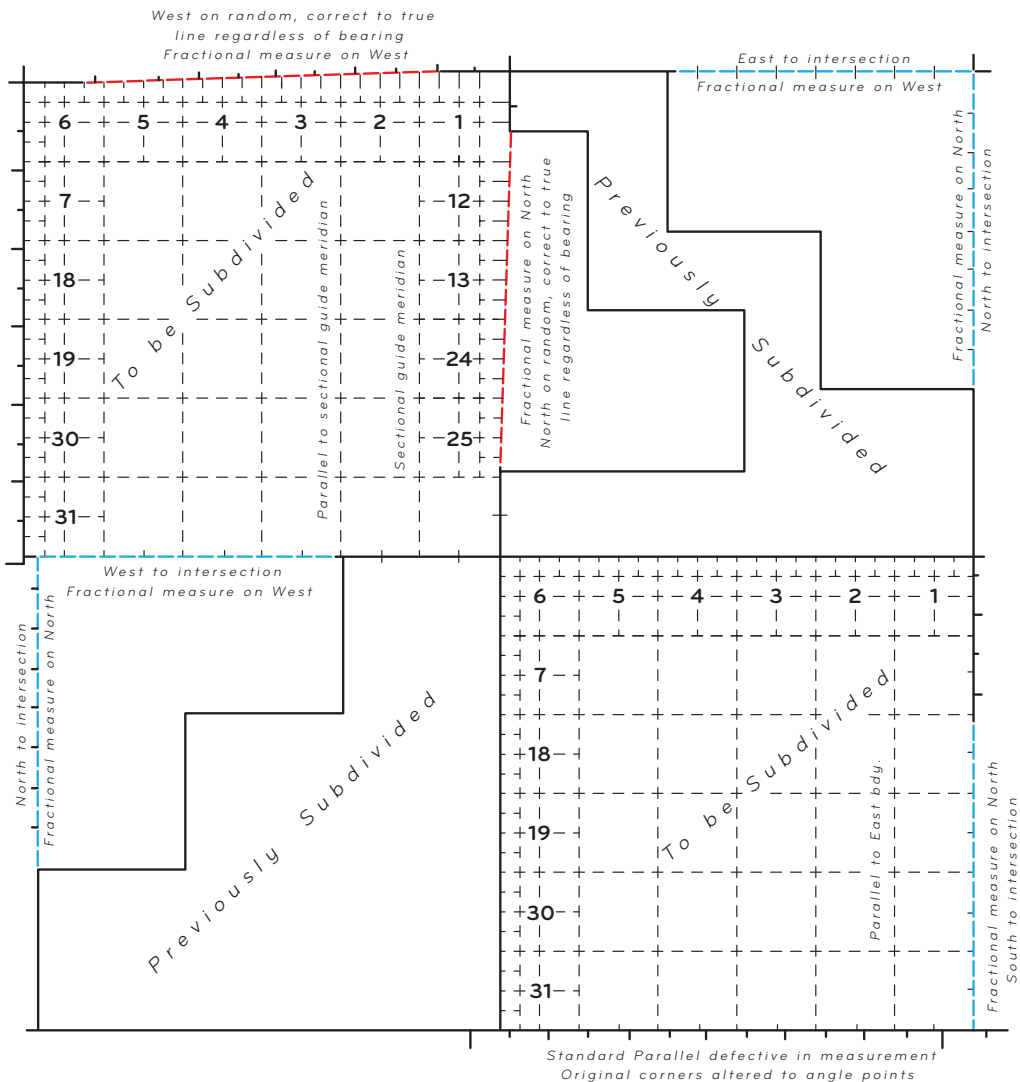


Figure 3-24. Various defective boundaries, showing methods for completing exteriors.

## Tables of Latitude and Departure and Error of Closure

**3-50.** Upon the completion of the survey of one or more township exteriors closing the figure of either a regular or irregular township, a table of latitudes and departures will be prepared with allowance for convergency of meridians. The maximum allowable error of closure is 1/4000 of the perimeter in either latitude or departure. If the limit is exceeded, additional retracements or other corrective steps may be necessary to perfect the survey. A demonstration of the closing errors, including every part of any closed figure embracing township exteriors, will be returned with the field tablets, computation sheets, and survey data files. Together with proper field procedures the error of closure can be a test of the accuracy of the alinement and measurement of the township exteriors (section 3-215). For allowable error of closure of a new survey against an official survey record see section 3-217.

## Subdivision of Townships

### Regular Boundaries

**3-51.** The boundaries of a township are within satisfactory governing limits for control of the subdivisional survey when the lines may be theoretically projected from the boundaries without closely approaching the rectangular limits. The danger zone has been placed at theoretical bearings exceeding 14' from cardinal, and the corresponding danger zone in respect to lengths of lines placed at theoretical adjustments exceeding 33 links per mile.

### *Meridional Section Lines*

**3-52.** Meridional section lines have precedence in the order of survey. They are initiated at the section corners on the south boundary of the township and are run north parallel to the governing east boundary. Meridional section lines are numbered counting from the east and surveyed successively in the same order. If the east boundary is within limits, but has been found by retracement to be imperfect in alinement, the meridional section lines are run parallel to the mean course ascertained by inverse from the most southerly to the most northerly corners as recovered and/or reestablished on the governing boundary. Regular quarter-section and section corners are established alternately at intervals of 40 chains as far as the northern-most interior section corner.

**3-53.** A meridional section line is not continued north beyond a section corner until after the latitudinal sectional line connecting east has been surveyed. In the case of the fifth meridional section line, both latitudinal section lines connecting east and west are surveyed before continuing with the meridional line beyond a section corner. The successive portions of the meridional lines are surveyed as convenient, but none should be carried beyond uncompleted sections to the east.

**3-54.** In the north tier of sections, the meridional section lines are connected to the objective section corner on the north boundary of the township. The quarter-section corners are established at a distance of 40 chains from the south, on the true line connecting the interior section corner and the objective section corner on the north boundary of the township. By this procedure, the excess or deficiency in measurement is incorporated in the north half mile, and double sets of corners are avoided where unnecessary. See section 3-104 for incorporation of the excess or deficiency when smaller subdivisions are to be protracted against the north boundary of the township.

**3-55.** Where the north boundary of the township is a base line or standard parallel, the last miles of the meridional section lines are continued as true lines parallel to the east boundary of the township. Permanent quarter-section corners are established at 40 chains from the south, and section corners are established at the points of intersection with the north boundary. The distances are measured and recorded to the nearest corners on the base line or standard parallel east and west in each case. New quarter-section corners for the sections of the township being subdivided are established on the line intersected and at mean distances, longitudinally, between the section corners, or at 40 chains from one direction, depending on the plan of the subdivision of the section.

### *Latitudinal Section Lines*

**3-56.** The latitudinal section lines, except in the west range of sections, are run between the objective section corners. The quarter-section corners are established on the true latitudinal curve connecting the objective section corners, at the midpoints, and the true lines are marked.

**3-57.** In the west range of sections the latitudinal section lines are connected to the objective section corners on the west boundary of the township. The quarter-section corners are established at a distance of

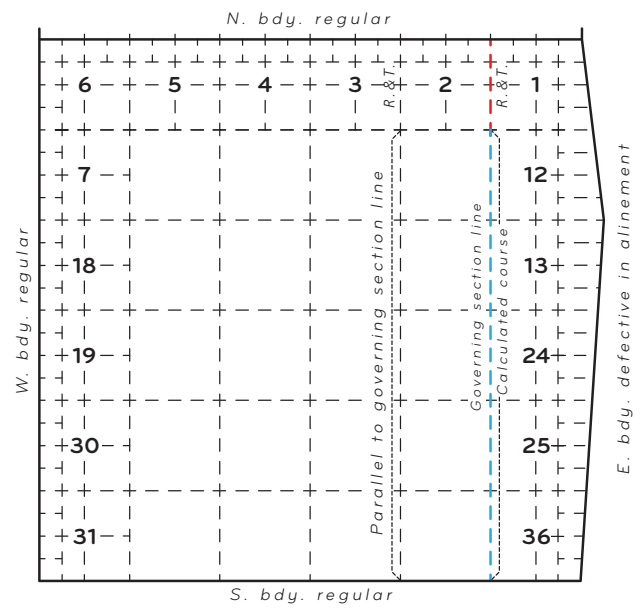




on the north boundary will not be properly related to those on the south boundary, even though the measurement of the north boundary is not defective. The north boundary is then said to be defective in position (figure 3-26). The first meridional line is projected as a sectional guide meridian due north to an intersection with the north boundary, where a section corner is established and the distances are measured and recorded to the nearest corners on the township line east and west. The intermediate quarter-section and section corners are established alternately at regular intervals of 40 chains, counting from the south unless the south boundary of the township is itself defective in alinement. The remaining meridional lines are established parallel to the sectional guide meridian.

**3-64.** Where, as shown in figure 3-27, the north boundary is not defective in position (nor within the danger zone) with reference to the corners on the south boundary (errors in alinement of the east boundary being compensable), the first meridional section line is established to intersect the objective section corner on the north boundary. The remaining meridional section lines are run parallel to the one first established, in the usual manner, to section corners established at the point of intersection or the objective section corners on the north boundary of the township as the case may be.

**3-65.** The excess or deficiency in measurements of the latitudinal section lines in the first range of

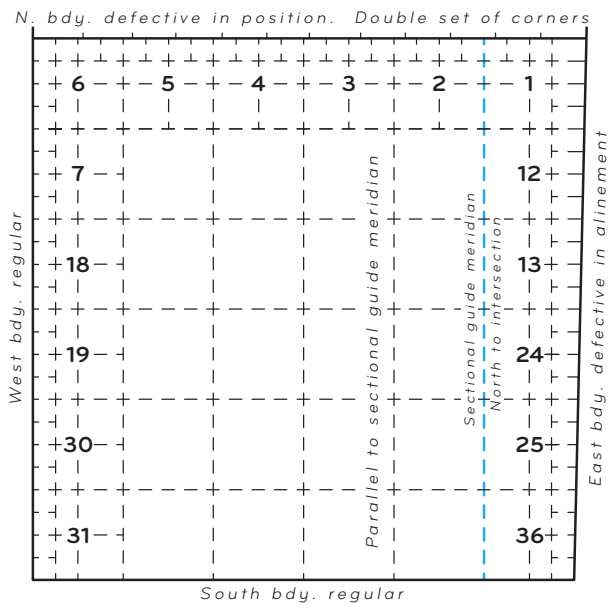


**Figure 3-27.** Projection of the first meridional section line as governing section line where the defective east boundary does not leave the north boundary defective in position.

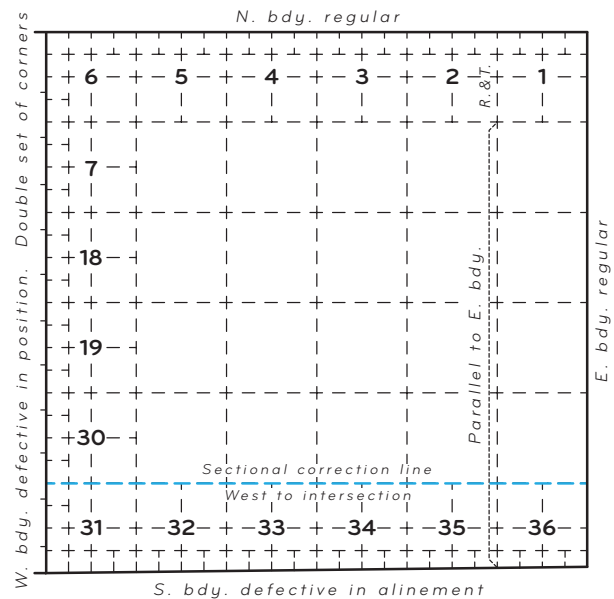
sections is incorporated in the east half mile. Elsewhere, unless the south boundary is defective in alinement, the latitudinal section lines are run in the usual manner.

**Sectional Correction Line**

**3-66.** If the south boundary of the township is defective in alinement and cannot be rectified so that the west boundary is defective in position, a sectional correction line is established (figure 3-28). This line is surveyed



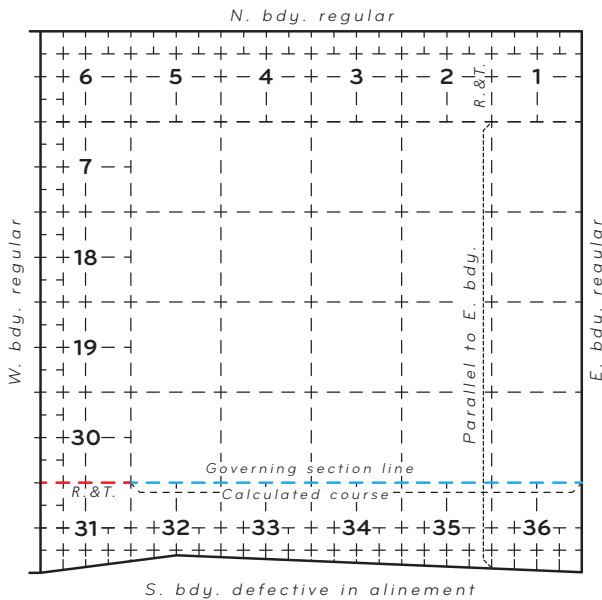
**Figure 3-26.** Projection of the first meridional section line as guide meridian where defective alinement of the east boundary leaves the north boundary defective in position.



**Figure 3-28.** Projection of the first latitudinal section line as sectional correction line where defective alinement of the south boundary leaves the west boundary defective in position.

on a true latitudinal curve initiated at the first regular section corner on the east boundary and projected to an intersection with the west boundary of the township, where a section corner is established and the distances are measured and recorded to the nearest corners on the range line north and south. The intermediate quarter-section and section corners are established at regular intervals of 40 chains, alternately, counting from the east.

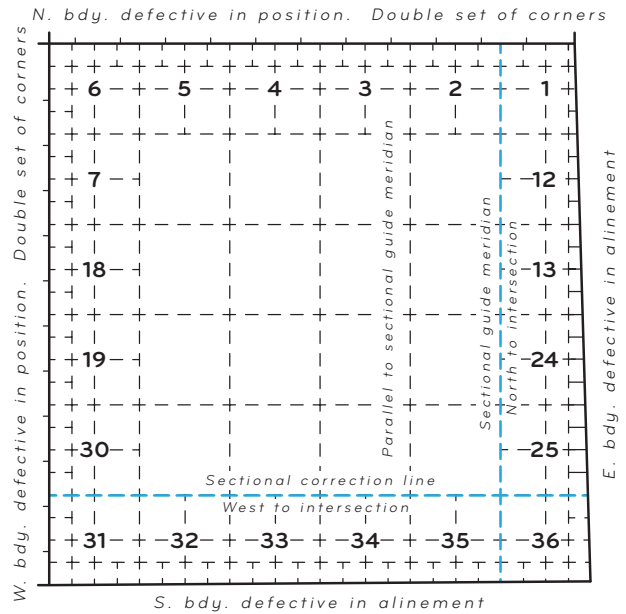
**3-67.** Where, as shown in figure 3-29, the west boundary is not defective in position (nor within the danger zone) with reference to the corners on the east boundary (errors in alinement of the south boundary being compensable), the first latitudinal section line is established to intersect the objective section corner on the west boundary.



**Figure 3-29.** Projection of the first latitudinal section line as governing section line where the defective south boundary does not leave the west boundary defective in position.

**3-68.** The section corners on the sectional correction line are established at the points of intersection of the meridional section lines alined in the normal manner. Thereafter, the quarter-section corners on the sectional correction lines are established at the usual midpoints except in the east and west ranges of sections.

Referring to figure 3-30, the quarter-section corner between sections 25 and 36 is established at 40 chains from the west if the east boundary is defective in alinement. Otherwise it is fixed at the usual midpoint position. The quarter-section corner between sections 30



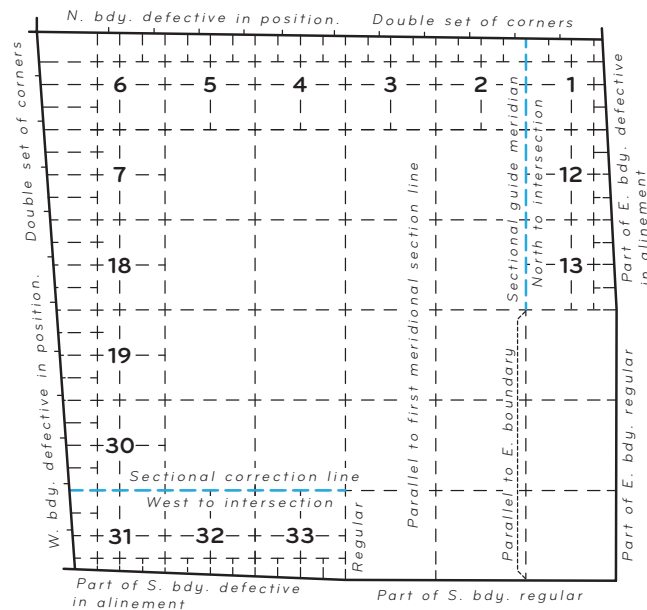
**Figure 3-30.** Projection of both the sectional guide meridian and sectional correction line where combination of defective conditions exists.

and 31 is placed at 40 chains from the east. The quarter-section corners on the meridional section lines in the south tier of sections are established at 40 chains south from the corners on the sectional correction line. The remaining subdivisional lines are continued from the sectional correction line in the usual manner.

**Partial Irregularity**

**3-69.** Where the south part of the east boundary, or the east part of the south boundary, is regular, and the balance is defective in alinement and not subject to rectification, the subdivisional survey is made regular as far as possible. The initial point for the sectional guide meridian, or for the sectional correction line, is determined by existing conditions. The first meridional section line is continued as a sectional guide meridian if the north part of the east boundary is defective in alinement and the north boundary is therefore defective in position (figure 3-31).

**3-70.** If the north boundary is not defective in position (nor within the danger zone), the first meridional section line is established to intersect the objective section corner on the north boundary of the township. The same principle is observed if the west part of the south boundary is defective in alinement, and the west boundary is not defective in position (nor within the danger zone). If the west boundary is defective in position, the sectional correction line is established on the true latitudinal curve (figure 3-31).



**Figure 3-31.** Projection of both the sectional guide meridian and sectional correction line in case of partial irregularity.

### Survey Record

**3-71.** The official record of subdivisional surveys including a sectional guide meridian, a sectional correction line, or other governing section line, is compiled in the usual order and appropriate explanatory remarks added to show the method and order of procedure used to establish the lines.

### Summary

**3-72.** A sectional guide meridian is created when the east boundary is defective to the point where the north boundary of the township is defective in position and double sets of corners are required on the north boundary (cannot be rectified with township to the north) (figures 3-26, 3-30, and 3-31). A sectional correction line is created when the south boundary is defective to the point where the west boundary of the township is defective in position and double sets of corners are required on the west boundary (cannot be rectified with township to the west) (figures 3-28, 3-30, and 3-31). “Governing section lines” are created when the defective conditions of the governing boundaries (east and/or south) do not create defective conditions along the north and/or west boundaries that would require double corners (figures 3-27 and 3-29).

**3-73.** The object of the plan is to secure the maximum number of regular sections. The sections adjoining the east boundary are regular if they conform to the usual rectangular limits. Where that is the case,

the quarter-section corners on the latitudinal section lines are placed at the normal midpoint position. The sections adjoining the south boundary of the township are not regular unless the meridional lines are established at 80 chains in length, and the sections are otherwise in conformity with the usual rectangular limits. Exceptions are noted in sections 3-80 and 3-83.

### Intersecting and Terminating Section Lines

**3-74.** A different type of intersection occurs where the lines of the rectangular system intersect or terminate on the boundaries of special surveys, including reservations or grants, State boundaries, U.S. Surveys, or the lines of various kinds of claims.

A corner of minimum control is normally established and monumented where a section line terminates at the intersection with a special survey. It is necessary to retrace the intersected boundary to the nearest corner in each direction to find and record the alignment, distances, and assure placement of the monument at the intersection.

**3-75.** Quarter-section corners are established between section corners for sections terminating on a reservation or grant boundary when needed to provide control for the survey of the adjacent public land survey system or for the identification of Federal interest lands.

**3-76.** The Bureau of Land Management has no general authority to survey or resurvey State boundaries. However, quarter-section corners should be established and monumented between section corners for sections terminating on State boundaries when needed to provide control for the survey of the adjacent public land survey system or for the identification of Federal interest lands. Although the corners themselves are monumented, State names will not be marked on the monuments unless specifically sanctioned by appropriate authority (sections 4-27 and 6-31).

**3-77.** A corner of minimum control monument may also be set when a nonterminal section line intersects the line of a surveyed mineral claim, forest homestead claim, small holding claim, U.S. Survey, or the like. In some instances, monumented corners may be needed for administrative, operational, litigation purposes, or to provide an interval of monumentation of 45 chains or less (section 10-36), in which event they should be provided for in the special instructions.

Where a line of the rectangular survey crosses a surveyed claim, the bearing of the intersected claim line



and the distance to the nearest corners are determined and described. In the case of a claim or conveyance located entirely within a section, a connection is made from a regular corner of the section to a corner of the claim or conveyance for inclusion in the official record.

Since the accuracy of lotting in the section and management of the remaining Federal interest lands depend on a correct location of the claim or conveyance, it may be desirable to retrace one or all of the claim or conveyance lines. If a multiplicity of claims or conveyances exists, their treatment will be covered in the special instructions.

**3-78.** If a survey is concluded upon an irregular boundary at variance with the lines of legal subdivision, or if the survey is continued on a blank line to acquire a definite location upon the opposite irregular boundary, but without monumenting the rectangular survey between the irregular boundaries, a monument is required at the point of intersection of the regular with the irregular line. However, if the survey is continued across the reservation or grant for the purpose of establishing and monumenting a full complement of corners for the control of the subdivision of a section so invaded, the point of intersection is determined but a monument may not be required.

**3-79.** Monuments established where a line intersects a boundary already fixed in position will thereafter control the direction of and the proportioning along the intersecting line. A failure to place the monument at the point of intersection does not alter the position of the line intersected but may cause interested parties to rely on the faulty position and engender confusion. Care should be taken to avoid this result. The line intersected will be retraced between the first corners to the right and left. Determination of the point of intersection by calculation alone is not permissible. Once a corner is monumented at the point of intersection, without gross error, it will ordinarily be accepted as control for both lines. Subsequent technical repositioning of the line closed upon will be avoided.

### Irregular Townships

**3-80.** The regular procedures described for subdividing regular townships cannot always be adopted. A township invaded by a large meanderable body of water, impassable objects, or a State, reservation, or grant boundary may lack a full linear south or east boundary. This may require controlling section lines to be established as offsets from the township exteriors,

with the section lines south and east of these controlling lines being projected to the south and east. The excess or deficiency in measurement and the resulting lots are placed against the irregular boundary. If only the north or west part of a township is involved, no departure from the regular order of subdivision is necessary since the excess or deficiency in measurement, and the resulting lots, will be placed to the north and west against the irregular boundary.

**3-81.** Where no part of the south boundary of a township can be regularly established, the subdivision may proceed from north to south and from east to west, incorporating the excess or deficiency in measurement and areas against the west boundary and the meanderable stream or other boundary limiting the township on the south. If the east boundary is without regular section corners and the north boundary has been run eastwardly as a true line, with section corners at regular intervals of 80 chains, the subdivision of the township may be made from west to east. In that case the excess or deficiency in measurement and areas are incorporated in the irregular east boundary. However, if the north boundary of section 6 is irregular, a sectional guide meridian, initiated at the easternmost regular section corner on the north boundary, is projected to the south to take the place of a governing east boundary. The subdivisional survey is then projected from north to south and from east to west, with the excess or deficiency in measurement and resulting lots on the east, south and west boundaries of the township. Figures 3-32 through 3-37 illustrate the principles that control the subdivision of irregular townships.

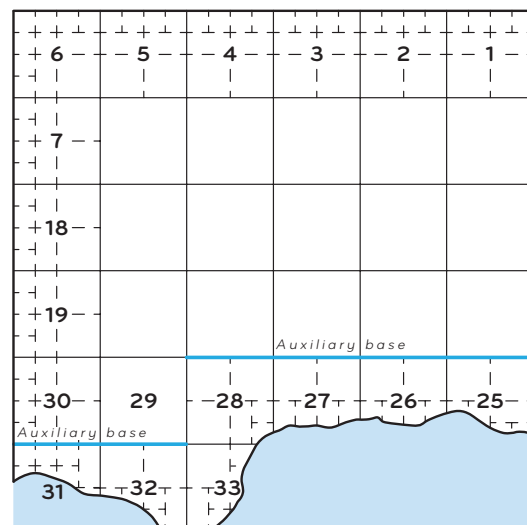


Figure 3-32. Use of auxiliary base.

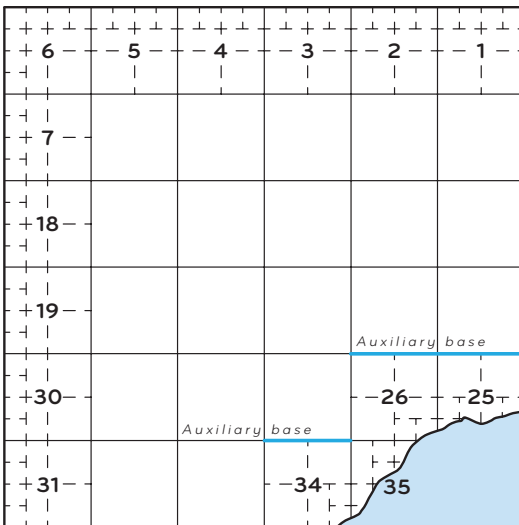


Figure 3-33. Use of auxiliary base.

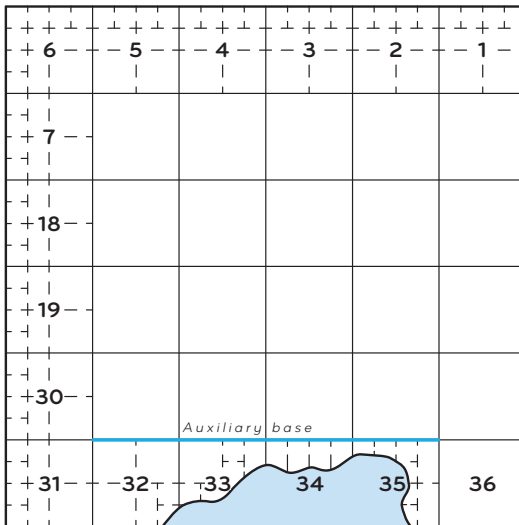


Figure 3-34. Use of auxiliary base.

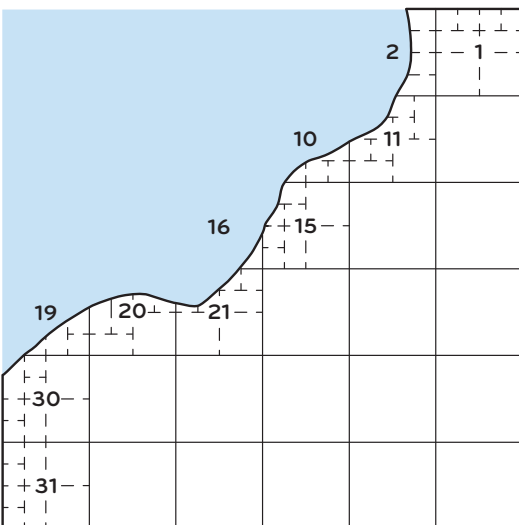


Figure 3-35. Regular subdivision of an irregular township.

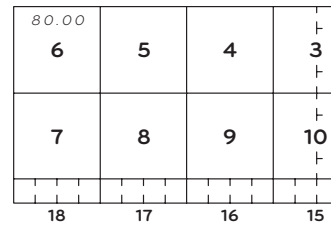


Figure 3-36. Subdivision from north to south and from west to east.

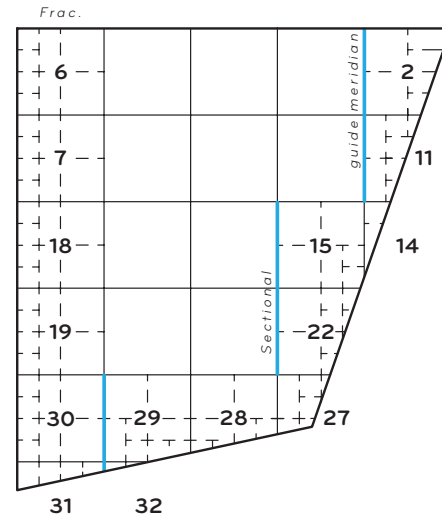


Figure 3-37. Subdivision from north to south and from east to west.

**3-82.** In the case of irregular townships the sections bear the same numbers they would have had if the townships were regular. That is, the section numbers are those relating to the governing boundaries.

## Extension and Completion Surveys

**3-83.** Original surveys sometimes involve the continuation of the subdivisional survey of townships previously subdivided in part only. These surveys include the completion of partially surveyed sections (section 3-125), of sections containing outlying areas protracted as surveyed, or of protracted section lines. If defective conditions are encountered in the previously established surveys, the problems concerning the procedure to be adopted multiply rapidly and require the greatest skill on the part of the surveyor. In the construction of new township plats the former practice of platting sections containing outlying areas protracted as surveyed has been abandoned as unsatisfactory and inconsistent with the surveying laws.

**3-84.** In Alaska, platting sections protracted as surveyed is done to accommodate the Alaska Native Claims Settlement Act (ANCSA) selections. Dashed lines represent the section lines and indicate which lines were not run and marked, and the distances given are parenthetical distances.

Akin to extension and completion surveys are townships in Alaska, often called “Tract A” townships, surveyed to accommodate State of Alaska land selections. The township exteriors are run and marked with a minimum of 2-mile monumentation. No interior section lines are run and marked, or protracted. Sections do not exist within these types of townships.

**3-85.** It is often necessary to depart from the general scheme. The possible combinations are too numerous to describe in detail. The complexities multiply with various combinations of valid existing rights, questions of accuracy of previously surveyed lines, and the condition of the corner monuments. The surveyor is reminded that the principles outlined in the Manual are in conformance with due process of law and bona fide rights as to location standards. See sections 3-24 through 3-26 for original survey situations and chapters V, VI, and VII for resurvey situations. When application of the general rules do not meet the due process of law and bona fide rights as to location standards, then exceptions to the general rules must be applied. Such exceptions to the general rules may be applicable in (1) townships with improvements, use or occupancy; (2) townships with significant riparian rights; or (3) townships without improvement, use or occupancy but with uneven distribution of valuable natural resources.

**3-86.** Most original surveys that are now to be extended or completed were executed many years ago when the remaining areas were considered wastelands. Due to the ravages of time and the inferior monumentation of many early surveys, obliteration may be so far advanced that dependent resurveys are needed to identify and remonument the limiting boundaries of the area to be surveyed. The surveyor often must retrace additional lines that are not the boundaries of sections containing the new areas to be surveyed. In such cases, only the positions of corners that control the location of Federal interest land should be monumented. Identified original corners adopted as control in reestablishing corners of the Federal interest land are to be rehabilitated or remonumented, as necessary. Corner restorations are made in accordance with the provisions of chapter VII.

**3-87.** The official record of necessary resurveys shall include an explanation of their purpose and extent, including all needed historical references to the related prior surveys. The detail is written in the usual field note record form, following the introductory statement.

The plat, in addition to the usual data, may carry a marginal memorandum or diagram that clearly defines what lines of the prior survey have been retraced as a basis for extending the new lines. If no changes are made in the former lottings and areas in the dependently resurveyed portions, state that the lottings and area remain as shown on the plat or plats approved \_\_\_\_\_ (date or dates).

### **Extension or Completion of Partially Surveyed Sections or Sections Containing Outlying Areas Protracted as Surveyed**

**3-88.** In extending or completing fragmentary surveys, consideration is given to the completion of (1) partially surveyed sections, and (2) sections containing outlying areas protracted as surveyed, returned on the previous plat. In such cases, it is usually necessary to complete the survey of each section in such a way as to protect acquired rights. The procedure adopted shall fix and mark the remaining quarter-section corners and the controlling corners not marked in the previous survey in a position that will control the center and other controlling lines as necessary to retain the form of the original areas within reasonable limits. If there are no valid existing rights or other interests to be protected as to location, it is not necessary to complete the survey of the section in a manner consistent with the previous plat.

**3-89.** The new quarter-section and controlling corners are regarded as reasonably fixed when (1) the new measurements produce subdivisions that meet or exceed the prescribed limits of closure, (2) the alinement does not exceed the rectangular limit of 21' from a cardinal course, and (3) the measurement does not exceed the rectangular limit of 25 links from 40 chains, or in proportion when the opposite portion of the section boundary was returned as more or less than 40 chains. This concession as to limits is made in the interests of simplicity where the rectangularity of both old and new surveys can thus be maintained.

**3-90.** The position of the corresponding corner on a new opposite boundary is controlled from only one direction if the old opposite distance was made to count from one direction only. If the old opposite distance

was made to count from two directions, the position of the new opposite corresponding corner is controlled from the two directions. The lengths of the two portions of the new line are made proportional to the two parts of the old opposite boundary.

**3-91.** If an original survey is within rectangular limits and valid existing rights or other interests is to be protected as to location, then the survey of a partially surveyed section, or a section containing outlying areas protracted as surveyed, is completed on the same plan begun in the original survey. When irregularity develops, the simplest method of survey that will correct any irregularities and provide an early resumption of regularity in the new subdivisional lines is adopted. The general rule is that each completed section will have four regular boundaries without offsets, with four governing section corners and four controlling quarter-section corners in such position as to maintain the integrity of the areas shown upon the original plat.

**3-92.** Modification of the general rule is necessary where extending or completing each of two sections in the above manner would cause an overlap or hiatus. In such a case each section is completed theoretically without regard to the other, and the position of each center line and other controlling lines is fixed. The most reasonable position for a common boundary between the two sections is then determined, and the new quarter-section corners are fixed at points that maintain the center lines in their positions. If the theoretical position for each quarter-section corner falls within 25 links of a common point, with allowance for variance in length of the center line, one corner may be fixed, which will secure maximum regularity in both sections.

**3-93.** The possible combinations of uncompleted sections are too numerous to discuss fully here. Directions must be given in the special instructions for the cases involved in an assignment, and surveyors will seek advice from the proper administrative office when irregularities develop. A diagram showing the exact field conditions should always accompany their reports.

**3-94.** Modification of the general rule for extending or completing sections is necessary, by Department decision, when a good faith location by local survey is followed by good faith use and occupancy; *Algoma Lumber Co. v. Kruger*, 50 Pub. Lands Dec. 402 (1923). A local survey made for the purpose of marking on the ground a protracted line, platted but not run by the Government, where executed within the allowable limit of error for an original survey of that date, and relied upon by an owner under title passed by the

United States in the placing of improvements upon the patented land, will not be disturbed, but it will be adopted by the Government as a boundary for closure of the survey of the adjoining public land.

**3-95.** The best test of the fitness of a proposed method for the completion of partially surveyed sections, or sections containing outlying areas returned as surveyed is to plat the subdivisional lines by protraction, therefore, the regular rules for subdivision of sections are applicable. The position of the new quarter-section corners, established to control the subdivision of the section in question, shall permit the center lines to the opposite corresponding original quarter-section corners to be connected in harmony with conditions shown on the original plat, disregarding the effect upon the subdivision of the newly surveyed land. Likewise, the lines connecting the sixteenth-section corners on the opposite corresponding boundaries of a quarter-section shall conform to the conditions represented on the original plat. When the subdivision-of-section lines are platted, the section is satisfactory if the integrity of the original areas is in no way violated.

**3-96.** The following guidelines should be followed in platting:

- (1) The new areas should be complementary to the original areas by extending the subdivision-of-section lines as already protracted upon the original plat. If poorly shaped lots or lots of too great or too little area result, then departure is indicated.

- (2) In the interest of regularity and simplicity of platting, the same meridional limit may be permitted as is ordinarily allowed in latitudinal section lines. A section may be considered regular if its boundaries do not depart more than is allowed to achieve rectangular limits for both alinement and measurement between the section and quarter-section corners (section 3-34). Such regular sections may be subdivided into quarter-sections and quarter-quarter sections as far as possible. An irregular section having three regular boundary lines may be subdivided in accordance with the usual rules for subdividing sections along the north and west boundaries of a regular township. An irregular section having two adjacent regular boundary lines may be subdivided by the same manner in which section 6 of a regular township is treated (e.g. sections 3-32, 3-54, and 3-57). All other sections should be treated as irregular,

with subdivision-of-section lines protracted to midpoints on the boundaries of the quarter-sections, except as a calculated proportional position for a sixteenth-section corner is made necessary by the showing of the original plat.

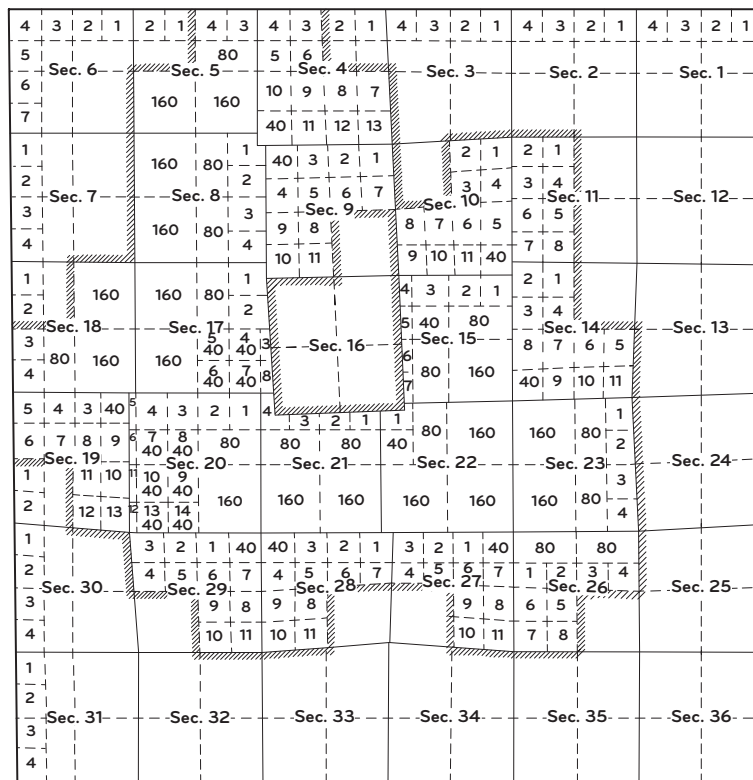
(3) All new lots are numbered beginning with the next higher number in the series shown on the previously approved plat, and proceeding in the usual order. The new series may begin with No. 1 if the irregular parts of the original area are not designated by lot number.

**Completion of Township Subdivision**

**3-97.** If no irregularities are found in the previously established lines the new survey may proceed normally. If defective conditions are encountered, the irregularities are not extended into unsurveyed sections any farther than necessary to incorporate the resulting excess or deficiency in measurement into suitable lots adjoining the former surveys. Preference should be given to extending all surveys from south to north and from east to west. If a better control is available by reversing the procedure in one or both directions, resulting in a simpler survey by minimizing the number of extra corners as well as lots, reversal of the procedure is warranted. In

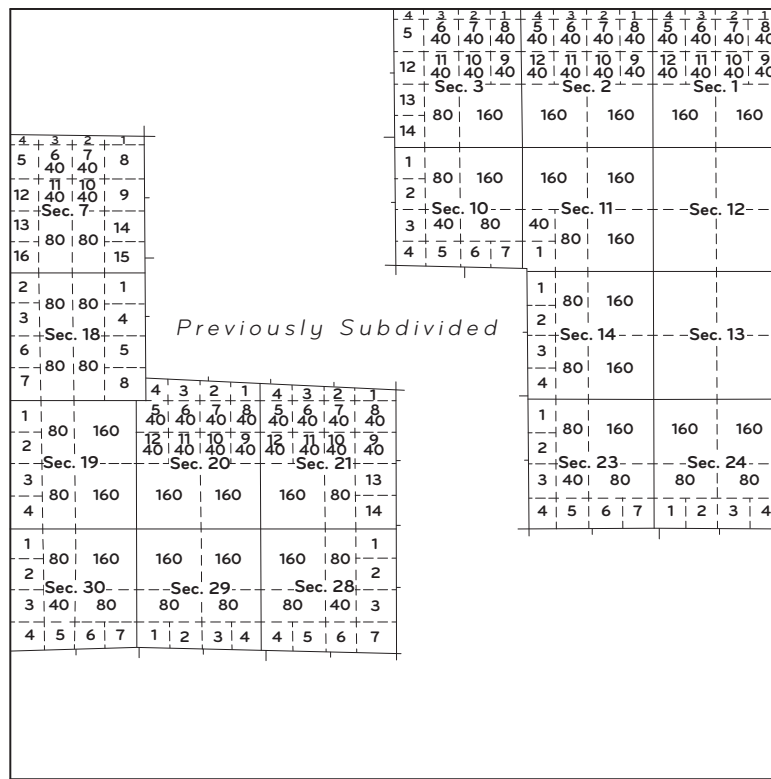
the event that the previously surveyed subdivision lines are defective, the new section lines may serve the function of a sectional guide meridian or a sectional correction line as required. The corners, from which the new surveys are initiated, are established as corners of four sections, or of two sections as appropriate. Where new section lines cannot be connected regularly with the previously established section corners without exceeding the rectangular limits in alinement (section 3-34), a section corner is established at intersection with the line of the old survey. The excess or deficiency in measurement of the intersecting section lines is incorporated adjacent to the old surveys. The original lines forming the boundary of the lands to be surveyed are retraced as already provided and the marks upon the original corners are appropriately modified as necessary. New quarter-section corners marked to control the subdivision of the new sections are established on the original lines at midpoints between the section corners, or at 40 chains from one direction, according to the manner in which a new section is subdivided.

**3-98.** There are often two or more ways in which a subdivision may be completed, but careful study of a sketch plat representing existing conditions will generally reveal the superiority of one method over another (figures 3-38 and 3-39).



**Figure 3-38.** Example showing completion of sections containing outlying areas protracted as surveyed and completion of subdivisional lines of a township with necessary lottings. On an actual plat, an area will be returned for each lot and each section.





**Figure 3-39.** Example showing completion of subdivisional lines of a township where sections containing outlying areas protracted as surveyed returned earlier have been cancelled. On an actual plat, an area will be returned for each lot and each section.

## Subdivision of Sections

**3-99.** Title 43 U.S.C. 752 and 753 (Rev. Stat. 2396 and 2397) contain the fundamental provisions for the subdivision of sections into quarter-sections and quarter-quarter sections. Sections are not subdivided in the field by Bureau of Land Management cadastral surveyors unless provision is made in the special instructions, but certain subdivision-of-section lines are protracted upon the official plat.

In the public land survey system a corner is fixed in position by operation of law. Corners marked in official surveys followed by use are fixed in position by monuments. Only a small portion of corners are marked on the ground in original surveys. Subdivision-of-section corners are generally not marked. Their positions are fixed on the plat by protraction. Their positions are fixed on the ground by the survey process of running (and marking) line between marked corners, and setting monuments.

**3-100.** The lands included in an entry or selection are identified on the ground by marked and fixed monuments, or by corner positions fixed by measurement and reference established in the survey. A United States

patent grants to the entryman title of ownership to an area defined on the ground by those fixed monuments and related by description and outline to the protractions on the official plat. The land included in an interim conveyance, lease, order, proclamation, reservation, selection, tentative approval, or withdrawal, and related by description and outline to the official plat, is also identified on the ground in the same manner.

### Subdivision of Sections by Protraction

**3-101.** The following sections address the procedures to be followed by the draftsman after receiving the field returns from the field surveyor. The subdivision of sections into aliquot parts, lots, parcels, and other parts is performed in the appropriate office section of the respective cadastral survey offices.

**3-102.** The draftsman is **first**, to plat each section in accordance with the field notes, and **second**, to subdivide each section as nearly as possible in conformity with the uniform plan, including connecting by straight lines opposite corresponding corners, incorporating excess or deficiency against the township boundary, creating as many aliquot part legal subdivisions as possible and following other lotting principles as stated in



are numbered commencing with No. 1 in the northeast, thence progressively west to No. 4 in the northwest, and south to No. 7 in the southwest.

**3-104.** Subsequent to the filing of the official plat, further subdivision of lots can only be accomplished by survey or supplemental plat. However, when it is administratively advantageous and prior to the official filing, the legal subdivisions adjoining the township exterior can be protracted into smaller than the customary lots. For example and again referring to figure 3-40, the sections bordering the north or west boundary of a regular township, excepting section 6, can be further subdivided by protraction into parts containing two half-quarter sections, four half-quarter sections, and four regular lots. In this example the north-north or west-west sixty-fourth section corners are established at 10 chains distant from the interior sixteenth-section corners, and the excess or deficiency in measurement is incorporated in the last distance to the township exterior. The same pattern is applied to section 6 on both its north and west boundaries.

**3-105.** The quarter-quarter sections are aliquot parts of quarter-sections based upon midpoint protraction. These lines are not indicated upon the official plat.

Sections are subdivided to contain as many aliquot parts as possible, but a departure from this practice is made where it would result in poorly shaped lots. In the case of the regular lots along the north and west boundaries of a township, and in other cases where a lot has a full normal width of 20 chains in one direction, it is generally advisable to avoid areas of less than 10 or more than 50 acres. In the instance of irregular lots along a meander line or other irregular broken boundary, where the width of the lot in both directions may be considerably less than 20 chains, resulting in lots of more compact form, it is generally better to avoid an area of less than 5 or more than 45 acres. Extreme lengths or narrow widths should be avoided. The longer direction should extend back from a meander line or claim boundary rather than along it. It is inconsistent that a lot lay partly in two sections, and it is generally better, when consistent with other rules, to avoid lots extending from one quarter-section into another quarter-section.

**3-106.** Sections that are invaded by meanderable bodies of water or by approved claims at variance with the regular legal subdivisions are subdivided by protraction into as many aliquot parts as possible and then lots, as may be necessary to form a suitable basis for

the administration of the Federal interest lands and to describe the latter separately from the segregated areas.

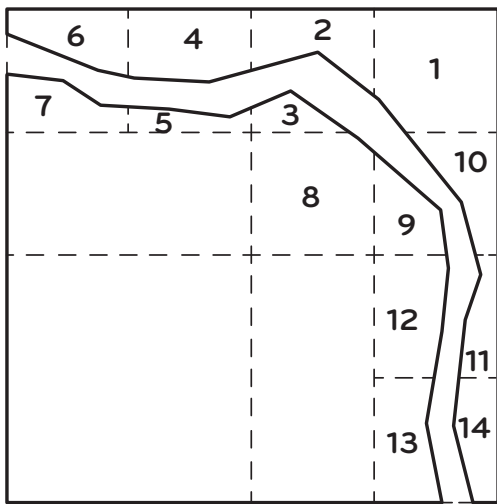
**3-107.** The meander line of a body of water and the boundary lines of private claims are platted in accordance with the lines run or connections made in the field. The sections invaded are subdivided by protraction as nearly as possible in conformity with the uniform plan. The subdivision-of-section lines are terminated at the meander line or claim boundary, but for platting purposes, the position of the subdivision-of-section lines is controlled as though the section had been completed regularly. In the case of a section whose boundary lines are in part within the limits of a meanderable body of water or within the boundaries of a private claim, the section lines are, for the purpose of uniformity, completed in theory and the protracted position of the subdivision-of-section lines is controlled by the theoretical points so determined.

**3-108.** The method of *subdivision by protraction* of fractional sections into lots is **first**, in accordance with the field notes, and **second**, as nearly as possible in conformity with the uniform plan for fractional sections. Protraction of subdivision-of-section lines will be made, as nearly as possible, in conformity with the procedures outlined for fractional sections in 43 U.S.C. 752(2)(cl. 3) and 753(cls. 2 and 4). Only in limited cases is there a significant difference between the two methods. See section 3-118 for *subdivision of fractional sections by survey*.

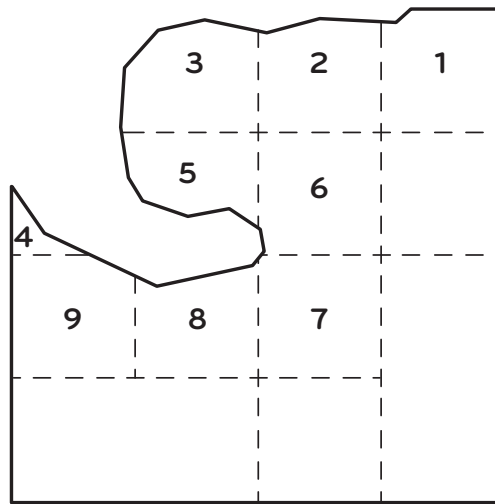
**3-109.** To visualize a uniform system for numbering lots of invaded sections and fractional sections, imagine the section divided by parallel latitudinal lines into four tiers, numbered from north to south. Then, beginning with the eastern lot of the north tier, call it No. 1, and continue the numbering west through the tier, then east in the second, west in the third, east in the fourth tier, until all lots have been numbered. These directions are maintained even though some of the tiers contain no lots. A lot extending north and south through two or part of two tiers is numbered in the tier containing its greater area. This method of numbering applies to any part of a section. A section that has been partly surveyed at different times will have no duplication of lot numbers (figure 3-41).

### Elongated Sections

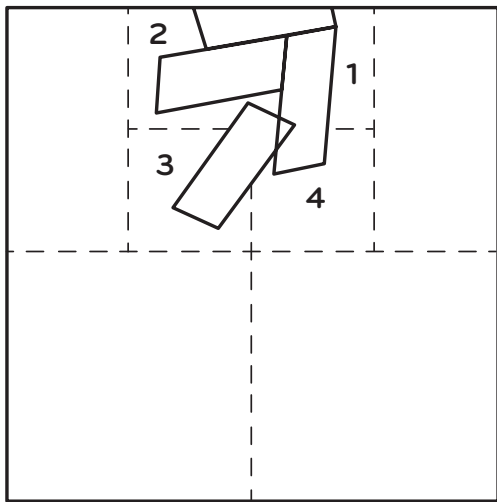
**3-110.** Prior to the 1973 Manual, when the length or width of a township exceeded 480 chains to such an



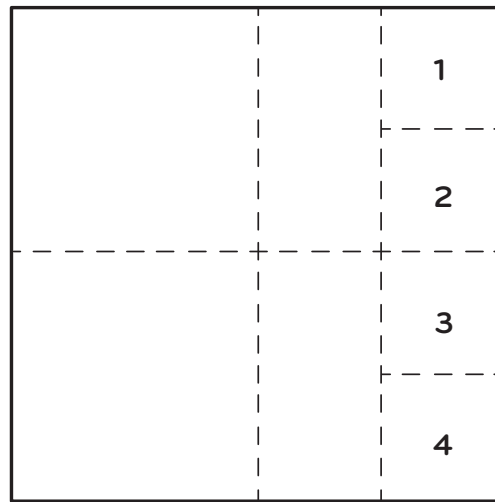
Meanderable River.



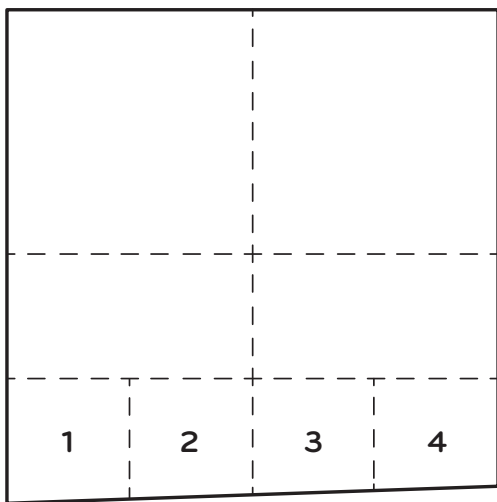
Meanderable Lake.



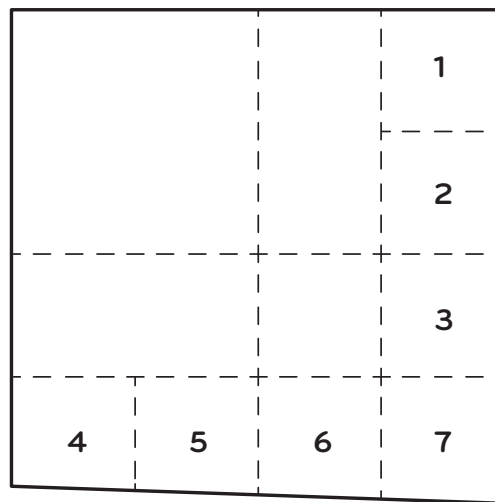
Mineral Claims.



E. bdy. defective in alinement.



S. bdy. defective in alinement.



E. & S. bdrs. defective in alinement.

Figure 3-41. Examples of subdivision by protraction.

extent as to require two or more tiers or ranges of lots adjoining the north or west boundary, the usual past practice was to lot all of the area beyond the regular legal subdivisions. Beginning with the 1973 Manual and in order to avoid possible confusion of descriptions, the lotting should be extended throughout the elongated half of the section as shown in figures 3-42 and 3-43. This will also apply to the platting of resurveyed sections insofar as Federal interest land is involved. Sections in excess of 120 chains are avoided by the creation of half-township or half-range numbers. This cannot be done where the elongated sections are situated in the interior of a township as the result of partially completed but grossly irregular former subdivisions. Lotting will then be extended as necessary.

**3-111.** If it has been necessary to establish a sectional guide meridian or a sectional correction line, lots may result along the east or south boundary of the township. The sections bordering the defective boundaries are subdivided on the same plan as sections bordering the north and west boundaries of a normal township.

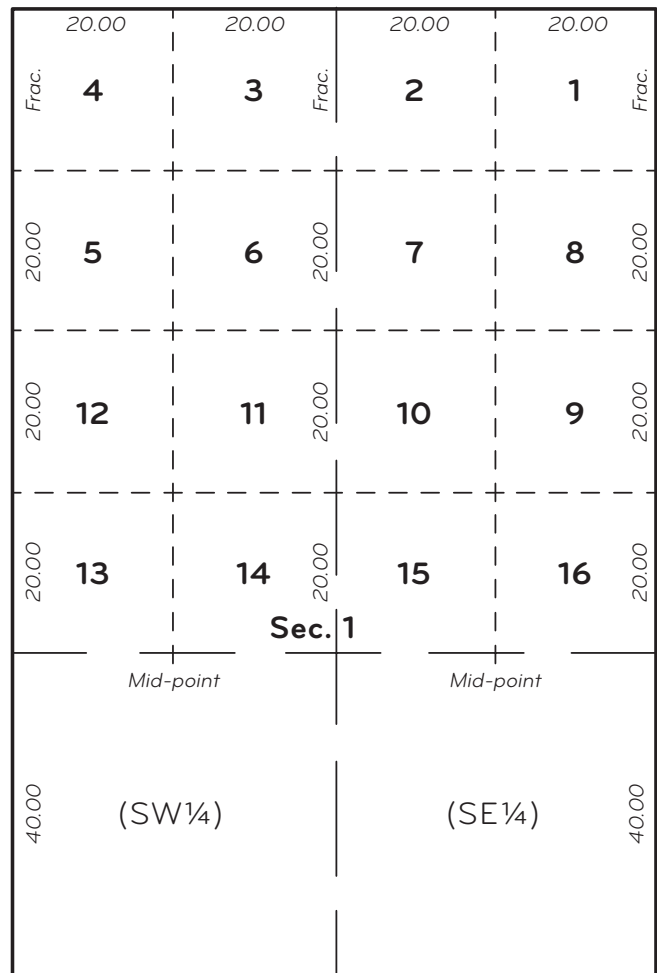
**Order of Procedure in Subdivision of Sections by Survey**

**3-112.** The method of subdivision of section by survey is established during the survey of the section exterior and a subdivision of section by protraction, when applicable.

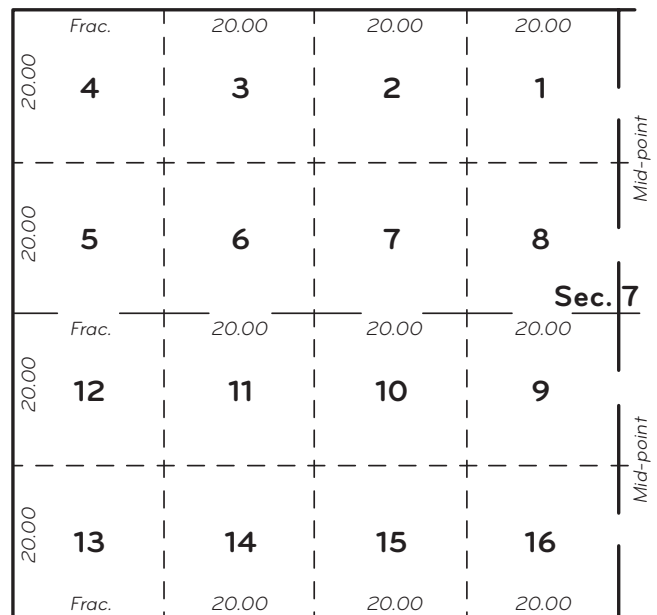
The subdivision of section by survey is performed during the field work by the field surveyor. The surveyor is guided by special instructions, the official plat(s), and the general plan of the rectangular survey system. When there is evidence of a prior survey or diagram, or use or occupancy within a section, the instructions outlined in chapters V and VI will be applicable and a corresponding plan of subdivision is proper.

**3-113.** Since the corners marked and fixed, or fixed by measurement and reference, in the original survey are controlling, it is essential that these corners be found, located, or properly restored, before the actual field work involving the subdivision of section is undertaken. The section boundaries should be retraced to develop the actual bearings and lengths of the lines between the marked corners.

The order of procedure is: First, identify or reestablish the marked corners on the section boundaries, including determination of the points for the necessary sixteenth-section corners. Next, fix the boundaries of



**Figure 3-42.** Extension of lotting in an elongated section. On an actual plat an area will be returned for each lot and the section.



**Figure 3-43.** Extension of lotting in an elongated section. On an actual plat an area will be returned for each lot.



the quarter-sections and then form the quarter-quarter sections or lots by equitable and proportionate division (see section 10-5).

**Subdivision of Sections into Quarter-Sections by Survey**

**3-114.** To subdivide a regular section into quarter-sections, run straight lines from the fixed quarter-section corners to the opposite corresponding quarter-section corners. The point of intersection of the lines thus run and fixed will be the corner common to the several quarter-sections, or in other words, the legal center of the section. This method of subdivision is outlined in 43 U.S.C. 752(2)(cl. 2) and 753(cls. 1 and 3). In this application, “straight lines” implied “lines of constant bearing” (43 U.S.C. 752(2)).

**3-115.** The quarter-section corners upon the lines terminating on the north and west boundaries of a regular township were established originally at 40 chains to the north or west of the last interior section corners. The excess or deficiency in measurement was incorporated into the legal subdivision next to the township or range line, as the case may be. If such legal subdivision corners, usually quarter-section corners, are lost they shall be reestablished by proportionate measurement based upon the official record.

**3-116.** Where there are double sets of section corners on township and range lines, the quarter-section corners on the township line for the sections south of the township line and on the range line for the sections east of the range line historically were not marked in the original surveys. In subdividing such sections new quarter-section corners are required. The new corners shall be placed as to suit the calculations of the areas that adjoin the township boundary, as indicated upon the official plat, adopting proportional measurements where the new measurements of the north or west boundaries of the section differ from the record distances.

**Subdivision of Quarter-Sections by Survey**

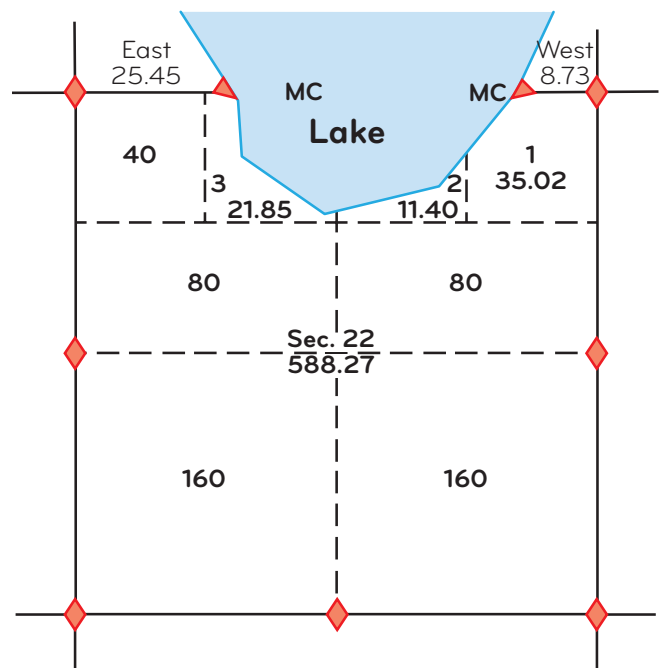
**3-117.** Preliminary to the subdivision of quarter-sections, the quarter-quarter or sixteenth-section corners shall be fixed as nearly as possible equidistant or proportionate measurement from two corners which stand on the same line, and between the quarter-section corners and the center of the section. On the last half mile of the lines terminating on township boundaries, they should be placed at 20 chains, proportionate measurement, counting from the regular quarter-section corner.

Subsequent to the establishment of quarter-quarter or sixteenth-section corners, the center lines of the quarter-section shall be run as straight lines between opposite corresponding quarter-quarter or sixteenth-section corners on the quarter-section boundaries. The point of intersection of the lines thus run and fixed will be the legal center of a quarter-section.

**Subdivision of Fractional Sections by Survey**

**3-118.** By law a fractional section is (1) a section containing outlying areas protracted as surveyed, or (2) an invaded section in which at least one quarter-section corner has not been or cannot be fixed. The method of subdivision by survey is outlined in 43 U.S.C. 752(2)(cl. 3) and 753(cls. 2 and 4). By rule the procedure for subdivision of the fractional section is to be as nearly as possible in conformity with the official survey.

**3-119.** The law presumes that a corner has not been fixed when: (1) the section line on each side of the corner position has not been actually run (figure 3-44) or, (2) the section line has been actually run but at least one corner on either side, on the section line at issue, has not been monumented (figure 3-45). The rule presumes that a section line has been actually run when a bearing and distance of the line is returned in the official survey record.



**Figure 3-44.** Fractional section. No bearing and distance returned between the meander corners.

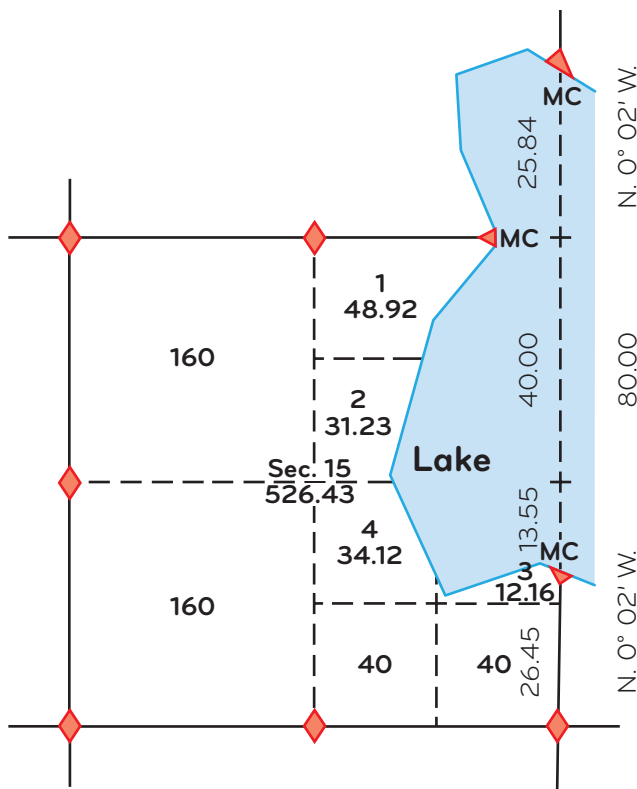


Figure 3-45. Fractional section. The section corner was not monumented.

**3-120.** The law provides that where no opposite corresponding quarter-section corners have been or can be fixed, the subdivision-of-section lines shall be ascertained, by running a line from the monumented corners due north and south, or east and west, as the case may be, to the water-course, reservation line, or other external boundary of such fractional section, as represented upon the official plat.

Under this subdivision-of-section method, the law presumes the section lines actually run and marked in the survey are due north and south, or due east and west lines, but usually this is not the case. Hence, in order to carry out the spirit of the law, it will be necessary in running the center lines through fractional sections to adopt mean courses, as ascertained from opposite corresponding section lines. Where an opposite corresponding section line does not exist, or the center line is platted parallel to one section boundary, run the center line parallel to the corresponding east, south, west, or north boundary of the section, as conditions may require.

**3-121.** The mean and parallel courses are based upon the weighted mean bearing of the controlling section line(s), equal to the bearing of the accumulated latitudes and departures of the controlling line(s) (figure 3-46).

This subdivision-of-section method is also used when the evidence conclusively shows that the meander corner, as well as closing or equivalent corners, was actually established as a terminal corner.

**3-122.** The basic principles outlined generally give satisfactory results except in special cases. The rules cannot be elaborated to rectify conditions that are at gross variance with the representations of the official survey record.

Examples of special cases that may warrant modification of the basic subdivision-of-section methods are situations where (1) the prescribed method does not result in lines and corners that represent the conditions on the official plat; or (2) a good faith rule occupation (section 6-35) has been established in reliance on a subdivision-of-section method reasonably consistent with the controlling survey plat(s). In such cases a corresponding modified plan of subdivision of section is proper.

### *Subdivision of Fractional Quarter-Sections by Survey*

**3-123.** By law, for subdivision purposes, a fractional quarter-section is within (1) a section containing outlying areas protracted as surveyed, or (2) an invaded section in which at least one quarter-quarter-section corner of the quarter-section has not been or cannot be fixed.

**3-124.** The subdivision-of-section lines of fractional quarter-sections shall be ascertained by running from properly established quarter-quarter or sixteenth-section corners with courses governed by the conditions represented upon the official plat. This can generally be accomplished by running due north and south, or east and west lines, as the case may be, to the water-course, reservation line, or other external boundary of such fractional quarter-section.

In running the center lines through fractional quarter-sections it is necessary to adopt mean courses, as ascertained from opposite corresponding section and subdivision-of-section lines, or run parallel to a boundary of the section or quarter-section, as conditions require (figure 3-46).

### *Survey of Partially Surveyed Sections*

**3-125.** In rare cases portions of the section boundaries are impassable or so insecure that acceptable monumentation is impracticable, or there is an administrative

Problem: Compute the weighted mean bearing of the N-S center line of fractional section 20.

The data shown in diagram 1 is measured data.

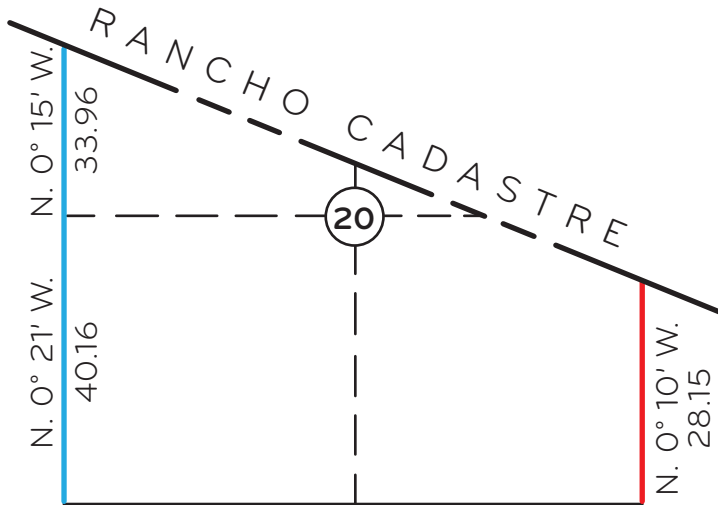


Diagram 1  
(Measured)  
(not to scale)

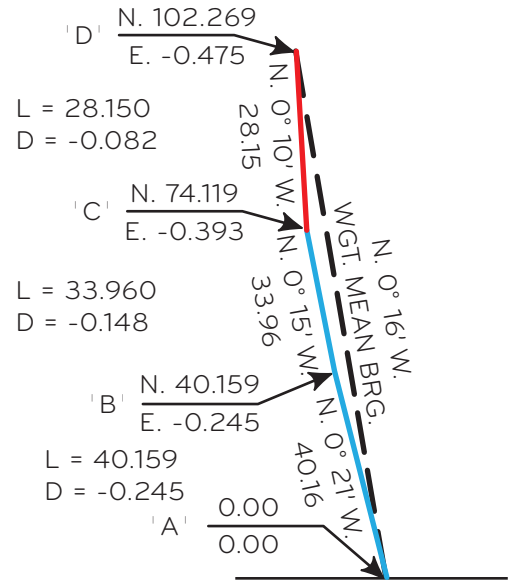


Diagram 2  
(Measured)  
(not to scale)

Traverse Method:

- 1) Traverse from 'A' to 'B' to 'C' to 'D'. See diagram 2.
- 2) Inverse from 'A' to 'D'.
- 3) The bearing 'A' - 'D' is N. 0° 16' W. = the weighted mean bearing.

Proportion Method:

- 1) The ¼ sec. cor. of secs. 19 and 20 was recovered. First compute the inverse for the sec. line:  
N. 0°18' 12" W. 74.12
- 2) Compute the difference in bearings between the east and the west section lines:  
N. 0° 18' 12" W. - N. 0° 10' W. = 8' 12" = 492"
- 3) Compute the sum of the lengths of the east and the west section lines:  
28.15 + 74.12 = 102.27
- 4) Compute the correction factor 'K'. Use the shorter (east) line:  
28.15 / 102.27 = 0.2753 = K
- 5) Compute the correction to the bearing of the west line:  
492" X 0.2753 = 135.45" = 2' 15"

**Mathematically, the weighted mean bearing will be closer to the bearing of the longer line than of the shorter line, therefore, the computed correction using the shorter line is applied to the bearing of the longer line.**

- 6) Compute the weighted mean bearing by, in this case, subtracting the correction from the bearing of the longer line:  
N. 0° 18' 12" W. - 0° 02' 15" = N. 0° 16' W. = the weighted mean bearing.

Figure 3-46. Weighted mean bearing example.

reason not to survey portions of the boundaries and yet a need exists for survey of the accessible area. These unsurveyed areas may be within sections on a protraction diagram, within sections or protracted blocks on an amended protraction diagram, or within an area where no protraction diagram exists. Since rules covering every set of conditions cannot be given, the methods to be used are set forth in the special instructions.

Although the running of traverse lines on the margin of impassable areas has been largely discontinued, such a survey is sometimes called for where rectangular boundaries cannot otherwise be completed within the section. The method must be authorized in the special instructions and supported by ample justification. In such surveys the angle points of the traverse line are given serial numbers in each fractional section, and the points are monumented. The subdivision-of-section lines are protracted only, unless a definition upon the ground is justified.

**3-126.** For sections within protraction diagrams, where rectangular limit requirements can be met, original surveys of the subdivision-of-section lines should follow the plan outlined by the protraction diagram. Where field conditions reveal that the rectangular limit requirements cannot be maintained, and the corners are not fixed in position by use, the protraction diagram will be abandoned and a new plan for survey provided by a new protraction diagram or by supplemental special instructions and diagram.

For sections within amended protraction diagrams the aliquot part corners are monumented at the latitude and longitude shown on or computed from the protraction diagram.

For areas within a protracted block the special instructions will set forth the plan for surveying the required areas, and the amended protraction diagram will be modified to reflect the new survey. When surveyed a protracted block will normally become a section containing the normal aliquot parts with the excess or deficiency against the previously surveyed boundary.

**3-127.** Figures 3-47 and 3-48 show rectangular boundaries of partially surveyed regular sections.

**3-128.** Figures 3-49 and 3-50 show rectangular boundaries of partially surveyed irregular sections where lottings are indicated. In figure 3-49 the whole closing error in latitude is incorporated as normally in the north

tier of lots. In figure 3-50 the whole closing error in departure is incorporated as normally in the west range of lots.

**3-129.** The field notes show only the true line courses and distances, the usual topography, the description of monuments, and a description of the difficulties or administrative need that warranted an elimination of parts of the section or sections.

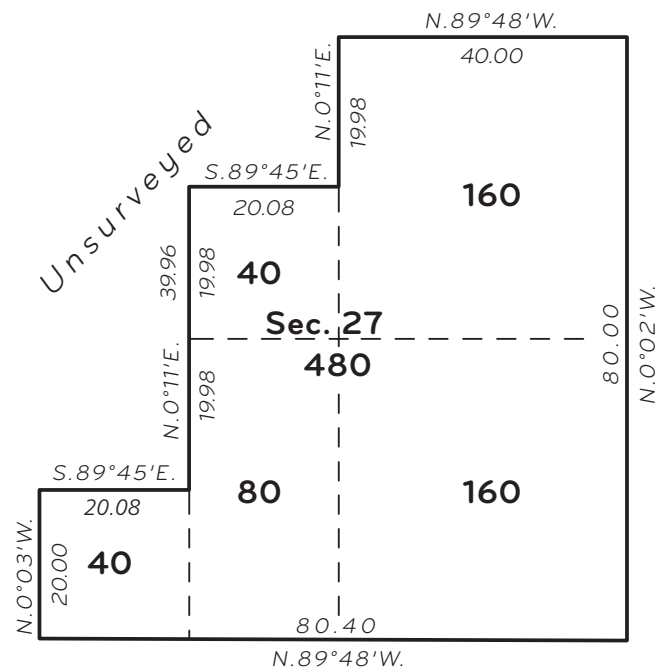


Figure 3-47. Rectangular boundaries of a partially surveyed regular section.

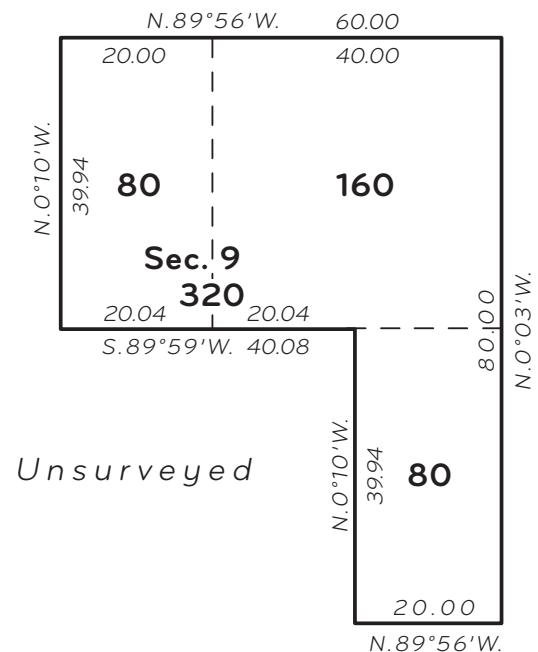
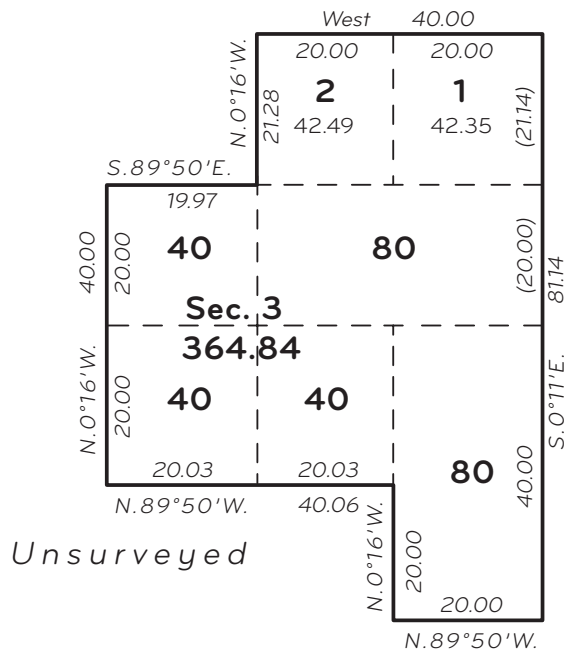
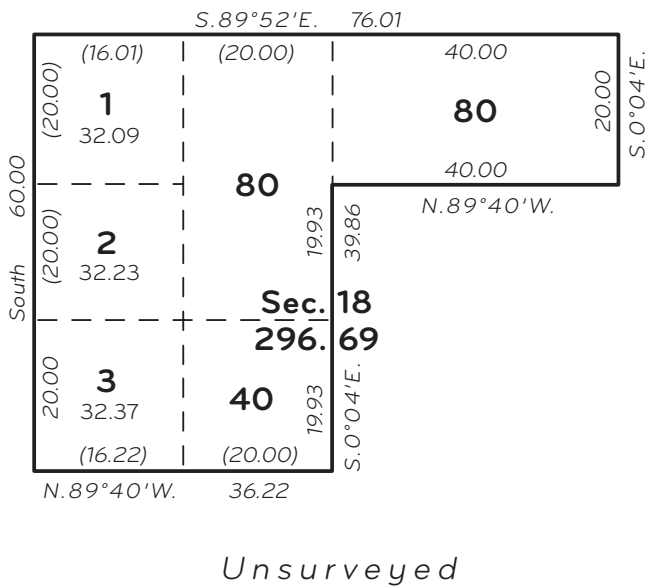


Figure 3-48. Rectangular boundaries of a partially surveyed regular section.



**Figure 3-49.** Rectangular boundaries of a partially surveyed irregular section adjoining the north boundary. Formerly protracted block 39 per the protraction diagram.



**Figure 3-50.** Rectangular boundaries of a partially surveyed irregular section adjoining the west boundary. Formerly protracted block 44 per the protraction diagram.

**3-130.** To subdivide a partially surveyed section, the remaining subdivision-of-section lines within the surveyed area are determined by running straight lines between the nearest fixed corners for the sectional center lines.

The remaining interior sixteenth-section corners on the sectional center lines are at midpoints between the exterior quarter-section corners and the center

quarter-section corner, except within the sections normally fractional. The center lines of the quarter-sections are completed on a similar plan. In all sections normally irregular, the excess or deficiency in measurement is incorporated in its normal position as shown on the protraction diagram.

**Subdivision of Sections by Local Surveyors**

**3-131.** The function of the local surveyor begins when employed as an expert to identify lands that have passed into private ownership. This may be a simple or a most complex problem, depending largely upon (1) the condition of the original monuments as affected principally by the lapse of time since the execution of the original survey, the inferior monumentation of many early surveys, or the workmanship of the original surveyor; (2) the degree of irrelatation between original corners; (3) the use and occupancy of the land; (4) the degree to which local surveys conform with the law, methods, and the exercise of ordinary intelligence under existing conditions; and (5) the presence of nonofficial surveys administered by Federal agencies, their employees, or agents.

**3-132.** The work of the local surveyor usually includes the subdivision of the section into the legal subdivisions shown upon the approved plat. In this capacity, the local surveyor is performing a function contemplated by law. He or she cannot properly serve the client or the public unless familiar with the legal requirements concerning the subdivision of sections.

**3-133.** In the event that the original monuments have become obliterated or lost, the local surveyor cannot hope to effectively recover the corner positions without a full understanding of the record concerning their original establishment and other evidence of establishment, subsequent recovery, or reestablishment. Nor can the local surveyor hope to legally restore or weigh evidence of subsequent corner location, use, or occupancy, until he or she has mastered not only the principles observed in the execution of the original survey, and later local practices, but also the principles upon which the courts and authorized administrative officials having jurisdiction over such matters have based their rulings.

**3-134.** The cadastral surveyor is required to establish the official monuments so that a proper foundation is laid for the subdivision of the section, whereby the officially surveyed lines can be identified and the subdivision of the section controlled as contemplated by law.



The local surveyor, who may be employed by a claimant, entryman, or owner to run subdivision-of-section lines and mark said corners, shall correlate the conditions as found upon the ground with those shown upon the official plat.

**3-135.** The Bureau of Land Management assumes no control or direction over the acts of local and county surveyors in the matters of subdivision of sections, evaluation of evidence of corner locations, and reestablishment of lost corners of original surveys where the lands have passed into private ownership, nor will the Bureau of Land Management issue instructions in such cases. It follows the general rule that disputes arising from uncertain or erroneous location of marked or unmarked protracted corners originally fixed by the United States are to be settled by the proper local authorities or by amicable adjustment. The Bureau of Land Management desires that the rules controlling the acts of its own cadastral surveying service, and other surveyors under its direction and control, be considered by all other surveyors as merely advisory and explanatory of the principles that should prevail in performing such duties. The Bureau of Land Management does not assume control, direction over, or responsibility for the acts of Federal employees performing or administering surveys not authorized by the appropriate Chief Cadastral Surveyor.

**3-136.** The rules for subdivision of sections by survey are based on the laws governing the survey of the public lands. Some cases are not covered by these rules, and when inquiry is made, the Bureau of Land Management will offer advice. The letter of inquiry should contain a description of the particular tract or corner, with reference to principal meridian, township, range, and section of the public surveys, together with a diagram showing conditions found.

### Summary

**3-137.** When any claimant, entryman, or owner has acquired bona fide rights as to location per 43 U.S.C. 772 to certain legal subdivisions, that claimant, entryman, or owner has rights as to the location of the identical ground location as represented by the same subdivisions upon the official plat, controlled by monuments on the ground. It is a matter of expert or technical procedure to mark out the legal subdivisions called for in an entry, claim, patent, selection, or order, and entrymen are advised that a competent surveyor should be employed.

In marking the corners of subdivisions-of-section, the surveyor shall identify the section boundaries, run and

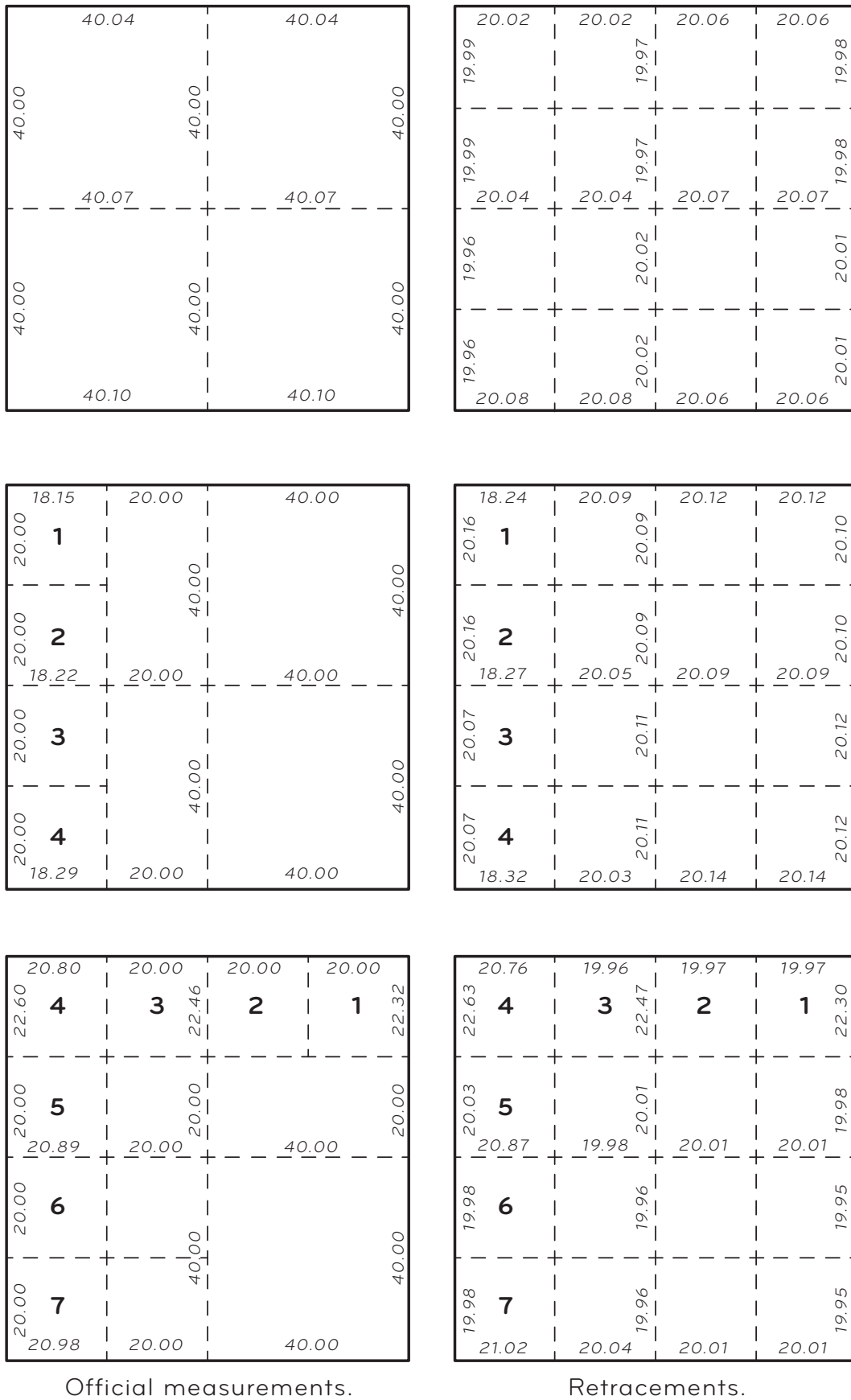
mark the section center lines, and fix the legal center of the section in common, in order to determine the boundaries of the affected quarter-sections. Then, if the boundaries of quarter-quarter sections, or lots, are to be run and marked, the boundaries of the quarter-section shall be measured, and the sixteenth-section corners fixed and marked in accordance with the proportional distances represented upon the approved plat. Finally, the quarter-section center lines are run and marked and the legal center of the quarter-section duly fixed.

Thus will be produced in the field the figure represented upon the plat, as nearly as possible, every part of the former in true proportion to the latter, where the elements of absolute distance and area have given way to corresponding proportional units as defined by the running and marking of lines between fixed monuments established in the original or controlling survey. Examples are provided in figure 3-51.

The law presupposes the fact taught by experience that measurements of lands cannot be repeated with absolute precision and that the work of no two surveyors will exactly agree. The governing law, 43 U.S.C. 752(2), states that "boundary lines which have not been actually run and marked shall be ascertained, by running straight lines from the established corners to the opposite corresponding corners." The protracted position of the legal subdivision corner on the survey plat is merely the first step in fixing the position of a corner. The corner position is fixed by the running and marking of the lines.

A decision to set aside previously fixed local survey legal subdivision corners must be supported by evidence that goes beyond mere demonstration of technical error, reasonable discrepancies between former and new measurement, and less than strict adherence to restoration and subdivision rules. Were the Federal Government obliged to open the question as to the location of a particular tract or tracts over technical differences or reasonable discrepancies, controversies would constantly arise, and resurveys and readjudication would be interminable. The law gives these activities repose.

It is unlawful for the surveyor to impair bona fide rights as to location. Proof of impairment of bona fide rights as to location per 43 U.S.C. 772, when lines have been run and marked and corners marked and fixed by local survey, must be positive evidence of an intentional departure from the legal principles governing recovery of original corner location, reestablishment and establishment of corner location, or subdivision of a section. Where the evidence of an extant subdivision-of-



Official measurements.

Retracements.

**Figure 3-51.** Examples of subdivision by survey showing relation of official measurements and calculated distances to retracements and indicating proportional distribution of differences.

section survey indicates (1) a good faith attempt to relate it to the original controlling survey, (2) conformance as nearly as possible to legal subdivision principles, (3) reasonable accuracy standards for that time and place, (4) sufficiency for identification of the legal subdivisions, and (5) without fraud or gross error, the statutory intent of stability of boundaries and title to lands will have been met.

Cadastral surveyors conducting resurveys must recognize that they are responsible for locating the limits of Federal interest lands and protecting the interests of the United States and of the general public as well as protecting the bona fide rights of the private landowner. The surveyor must act in an impartial manner when evaluating the local survey evidence. A rule works in favor of and against all parties of interest equally. The final record should be transparent and complete.

## Protraction Diagrams

### Protraction Diagrams—Plan of Survey

**3-138.** Official protraction diagrams are intended to provide a basis for the administration and management of unsurveyed Federal lands for all purposes short of conveying title. Such protractions can become the basis of land location for leasing purposes and for various administrative boundaries, including wilderness, National Recreation Areas, special use areas, withdrawals, and selections. For further discussion on protraction diagrams and water boundaries see section 8-196. For further discussion on plats of protraction diagrams see section 9-114.

Protraction diagrams should not be treated as “protracted subdivision township surveys.” The latter typically have run and marked exterior township lines and protracted section lines. The protracted section lines are represented as dashed lines indicating that they were not run and marked and the distances given are parenthetical distances.

**3-139.** The State of Alaska or an Alaska Native Corporation can elect to receive patent to certain lands in Alaska on the basis of protraction diagrams (43 U.S.C. 1635(c)(3) and 1637). In addition, protraction diagrams are used to describe certain lands selected by the State of Alaska. Upon tentative approval of such selection by the Secretary of the Interior, subject to valid existing rights, all right, title, and interest of the United States in and to such lands is deemed to have

vested in the State as of the date of tentative approval (43 U.S.C. 1635(c)(1)).

Protraction diagrams are also used to describe certain lands to be conveyed to an Alaska Native, Native Corporation, or Native group. Subject to valid existing rights and such conditions and reservations authorized by law as are imposed, the force and effect of such an interim conveyance shall be to convey to and vest in the recipients exactly the same right, title, and interest in and to the lands as the recipients received had they been issued a patent by the United States (43 U.S.C. 1621(j)(1)). In other words, an interim conveyance vests the same rights, title, and interests as would have been received if issued a United States patent.

Upon survey of lands covered by an interim conveyance, a patent is issued to the recipient. The boundaries of the lands as defined and conveyed by the interim conveyance cannot be altered but may be redescribed, if need be, in reference to the plat of survey. The Secretary shall make appropriate adjustments to assure that recipients receive their full entitlement.

**3-140.** The locations depicted on the protraction diagrams are based on the best available evidence; however, the precise location for many claims and special surveys are uncertain. As a result, there are special survey parcels and leases described by legal subdivisions that are actually located miles from the location shown on the protraction diagram.

The process of surveying a protracted tract or legal subdivision while protecting its location based upon the protraction diagram can involve extensive work. First, all the corners on the exterior of the unsurveyed area controlling the corners to be established must be found or reestablished by dependent resurvey. Second, using the protraction diagram as the record, the protracted township corners must be located. Only then can the location and establishment of the needed township subdivision lines take place, followed by the needed monumentation.

### Amended Protraction Diagrams

**3-141.** Protraction diagrams developed in two forms. Previous to 1993 corner positions were defined by bearing and distance with reference to the exterior boundary of the protraction. Subsequently, the process was amended and corner positions are now defined by geographic coordinates, defining all interior rectangular corners and corners necessary to protect prior existing rights and special areas. The revised procedure adds

more stability to land location and corner positions within protraction areas, allows a more economical corner position location procedure, and uses new developments in geographic position determinations. Any existing diagram revised or new diagram created by this procedure is referred to as an amended protraction diagram (see specimen plat, appendix V).

The surveyed exterior boundaries are as depicted on the latest official surveys. The interior portion of the diagram is constructed to produce the maximum number of regular sections following the general scheme, and an initial point for the interior subdivision is placed to accomplish this goal. Coordinate values, called the Plan Of Survey Coordinates (POSC), are published on the amended protraction diagram and determined for all interior section corners as well as corners of existing withdrawals and valid existing rights that fall in protracted blocks.

### Protracted Blocks

**3-142.** Protracted block is a designation for an area of uncertain acreage that lies between the coordinate-based interior and an existing surveyed line that is a boundary of the protraction or the boundary of a special survey within the protractions. Protracted blocks provide a buffer between protracted section corners defined by the POSC and any existing survey lines. These blocks are configured and dimensioned the same way as a section that is adjacent to an existing surveyed boundary. A protracted block will not be described as less than a full block and will not be lotted or subdivided until surveyed. Protracted blocks will be large enough to ensure that protracted sections do not invade existing survey lines, including special surveys. In order to avoid confusion with section numbers, the protracted blocks are designated beginning with number 37 or the next number above the highest protracted number already used.

**3-143.** Since the actual position of the existing survey on the ground is uncertain; the area of the protracted block is also uncertain and is shown in parentheses on the plat. The boundaries of a protracted block are normally formed by (1) a protracted line between two POSC corners, (2) the existing surveyed line on the outboundary of the protraction, and (3) two protracted lines. The protracted lines are designated either as bearing, or as random and true, from the POSC corner points within the protraction to the existing protraction outboundary.

The protracted block may be bisected by a meanderable body of water or special survey, creating two or

more separate parcels of land within the boundaries of the block. Normally these separate parcels will be combined to form a single protracted block. This single block is made up of every parcel within the block not included in the meanderable water body or special survey, even those too small to appear on the amended protraction diagram, such as islands, gaps between special surveys or within a group of mineral surveys. However, if the configuration of the parcels or the accuracy of the location of the existing special surveys or water body warrants, it is acceptable to create more than one protracted block.

**3-144.** When protracted lines close on an interior corner or a terminal line, it will be necessary to use a random and true line instead of a designated bearing line.

If a line is projected on a bearing from a POSC to an existing boundary corner, and a line is projected on a bearing from another POSC to the same existing boundary corner, they might meet before intersecting the existing corner. Therefore, one of the lines is run random and true to the existing corner. The random and true lines are labeled R/T on the plat.

## Developing Amended Protraction Diagrams

### Guidelines for Preparing Amended Protraction Diagrams

**3-145.** Amended protraction diagrams represent the plan for extending the rectangular survey system over unsurveyed Federal lands based upon assigned latitudes and longitudes for protracted corners, designated bearings for lines intersecting previously surveyed boundaries, and designated random and true lines connecting protracted corners with previously surveyed corners. The goal is to stabilize the interior of the protraction by assigning coordinates to section corner positions, called Plan of Survey Coordinates, and to create the maximum number of regular sections in the protracted area consistent with existing conditions. It is important to understand that these protraction diagrams do not absolutely fix corner positions, but are a plan of survey for defining corner positions more accurately than existing protraction diagrams whose accuracy and completeness vary considerably. The inherent imperfection of field survey procedures result in minor variations in positions when corners are established and monumented on the ground during the official survey.

Significant deviations between the amended protraction diagram and the field survey will be addressed in the special instructions at the time protraction areas are surveyed. Where possible, an amended protraction diagram should be consistent with the location of the original protraction diagram.

**3-146.** The amended protraction diagram standards have been designed to be extremely flexible. The amended diagram can be based on the existing diagram, on a selected point within the township usually near the southeast corner of the protraction, or on a combination of the two. By this process as many corners as possible within the protraction will have POSC latitude and longitude coordinates that will allow protraction-based descriptions to be located on the surface of the earth to a high degree of reliability. Unlike existing protraction diagrams in which corners could move every time a different bearing, distance, or position is found on the exterior protraction boundaries, amended protraction diagram protracted corner positions are not dependent on the position of an existing corner or surveyed line once its POSC have been determined. Protracted blocks, which are areas with uncertain acreage, will be used to form a buffer between the coordinate-based interior and the previously surveyed lines of the exterior perimeters. Therefore, even when the positions of the existing surveyed lines forming the protraction boundaries are uncertain, the plan of survey for the protracted area would not change, since POSC have been assigned to corners within the protraction.

**3-147.** Areas within an amended protraction diagram remain unsurveyed until such time as there is an approved official survey that returns the land as surveyed. The POSC represent the latitude and longitude at which the corners will be placed if a survey is done and are perfect positions on the surface of the earth. If there is a need to determine the position of a protracted corner for some administrative purpose, but not a need for an official survey, the position of the corner can be estimated accurately based on the control available at the time. But, it is only an estimate since the corner has still not been established and the land continues to be unsurveyed. At such time as an official survey is required, special instructions will be prepared specifying the control to be used, normally the nearest control and the latest adjustment.

**3-148.** As the coordinate values for the geographic position of the available control stations are refined, slight changes in the control coordinate values occur. The POSC do not change when the geographic

position of the control changes slightly because the POSC are calculated based on the initial point of the protraction, not on the geographic position of existing control corners.

**3-149.** The first step in creating an amended protraction diagram is to determine the most reliable coordinates (latitude and longitude, State plane, etc.) for the surveyed boundaries of the protraction, any existing special surveys within the protraction, and the shoreline of meanderable waters within the protraction. The coordinates of the exterior boundaries may be generated by the Geographic Coordinate Data Base (GCDB) process, or any reliable source. As part of this process, it may become apparent that certain previously surveyed lines or whole townships should be evaluated for cancellation. Unpatented mineral surveys that are no longer valid should be canceled. If necessary, these surveys will be canceled at this time and the protraction diagram extended to include the canceled area. Since the protracted blocks are a buffer between the corners with POSC and the existing surveys, accurate coordinates for the monumented positions along the outboundaries are desirable but not essential. Protracted blocks are generally the same size as a section, but may be larger or smaller depending on the reliability of the existing surveys. Where existing surveys are known to be reliable, protracted blocks may be less than a section, but where the existing surveys are extremely unreliable and large discrepancies with the record are found, protracted blocks can be enlarged to ensure that protracted sections do not invade existing survey lines.

The next step is to decide on the procedure to be followed. There are two basic methods: (1) using the plan of survey of the existing protraction diagram, or (2) creating a new protraction from a selected initial point, usually near the southeast corner of the protraction.

### **Determining the Outboundaries of the Amended Protraction Diagram**

**3-150.** The coordinates of the existing corners forming the outboundaries of the protraction may be determined by (1) GCDB coordinates, (2) mapping coordinates, or (3) a combination of GCDB and mapping coordinates. Interagency and intergovernmental cooperation, coordination, and consultation is critical for protraction diagram construction where the land status is mixed, Indian land is involved, water bodies are to be segregated, or the data will be integrated into mapping and geographic information systems. The identification of all existing leases, withdrawals, administrative boundaries, and



other interests with a fixed position that are to be protected will be done at this planning stage.

The existing surveys will be evaluated. Surveyed lines extending into or across the protraction will normally be canceled to allow for a greater number of POSC corner points. There may be some areas where whole townships will be canceled because of improperly executed, grossly erroneous, or fraudulent surveys.

The outboundaries of the protraction will follow the boundary of the land previously returned as surveyed but not canceled and may include subdivision-of-section lines on partially surveyed sections.

Coordinates of the corners along the outboundaries of the protraction will be calculated; however, those values should not be shown on the plat. The plat will show a heavy-weight line for previously surveyed lines, and no coordinates or tick marks will be shown for the existing corners on the plat(s).

### Construction of the Amended Protraction Diagram

**3-151.** All POSC section corners within the protracted areas will be assigned geographic coordinates. These coordinates will be computed to establish intervals of 80-chain horizontal distances at ground or mean ground elevation on all township boundaries and subdivisional lines, except for lines intersecting previous surveys. See sections 9-114 through 9-118 for construction of plats of protraction diagrams.

#### *Method 1 (Dependent)*

**3-152.** The land status will be checked to determine if there is a need for the amended protraction diagram to protect the existing protraction either wholly or partially. Where withdrawals, administrative boundaries, or selections follow the protraction or where there is extensive leasing, it is desirable to follow the plan of survey established by the existing protraction diagram. The decision should be confirmed by the approving official prior to beginning construction of the diagram.

**3-153.** POSC corner positions within the protraction that are dependent on existing corners on the protraction outboundary are computed from the coordinate position of the existing corner and held fixed. The line from the POSC corner to an intersection with the existing boundary is shown with a designated bearing. Even though the POSC position is determined from the existing corner on the outboundary, the line shown on the

final protraction diagram may not actually intersect the existing corner depending on the accuracy of the coordinates determined for that existing corner. The POSC are based on those previously determined coordinates, however, and they will be used in future surveys to determine the POSC corner position regardless of what occurs on the outboundary. Even if more accurate coordinates are determined later for the outboundary corner, the connecting line from the protracted section corner will still be surveyed to an intersection with the existing boundary. All POSC corner positions that are dependent upon existing corners should be computed first, followed by those independent of the existing boundaries and beyond the buffer or protracted blocks.

#### *Method 2 (Independent)*

**3-154.** When there is no need to follow the existing protraction diagram or when no protraction exists, an initial point will be selected, usually near the southeast corner of the amended protraction diagram, from which all other POSC within the protraction will be computed. In a regular township, the initial point would be the southeast corner of section 26 and would be positioned 1 mile from the east boundary and 1 mile from the south boundary. In this type of protraction there is no need for base lines, principal meridians, standard parallels, guide meridians, sectional correction lines, or sectional guide meridians because convergency is accounted for in each township and any error in the existing surveys is accounted for in the buffer created by the protracted blocks. Lines of designated bearing or random and true lines will be extended from the POSC corners within the protraction to the existing surveyed lines forming the protraction outboundary.

#### *Method 3 (Combination)*

**3-155.** In large protractions, a combination of methods 1 and 2 may be appropriate. If only a portion of the protracted area has conditions that require conformity with the existing protraction diagram (method 1), the rest of the area could be protracted using method 2.

## General Rules on Surveying Amended Protraction Diagrams

### A Plan of Survey

**3-156.** To survey any portion of an unsurveyed area shown on an amended protraction diagram, follow the

method and order of procedure in the special instructions and the general rules set out herein to execute the survey. The special instructions will address the control to be used, latitude and longitude of control, general field methods, and special methods that may be required.

## General Rules

**3-157.** The following general rules are intended as guidelines for the preparation of the special instructions and the execution of field surveys. Special procedures protecting valid existing rights and conforming to fixed corners while maintaining the intent of the protraction must be developed and set out in the special instructions. It may be necessary to modify portions of the protraction to resolve unforeseen conditions. The key point of the General Rules is that they are flexible and may be modified by the special instructions due to technological changes in survey methods, conditions on the ground, and the complexity of the protraction diagram:

(1) When section corners are to be monumented, based on an amended protraction diagram, the best available control stations should be selected and the latest adjustment or epoch of the North American Datum 1983 (NAD 83) coordinate values will be used to determine the position of the corner points.

(2) When a subsequent survey is to be done and a newer NAD 83 adjustment is available with differing control coordinate values for the same control stations, the latest NAD 83 coordinate values should be used to position the corner points. These latter positions could differ slightly from the corner positions monumented in an earlier survey. Once a corner point is monumented, approved, and filed in an official survey, it is fixed in position, similar to a corner monumented in an original survey under the public land survey system.

(3) When appropriate, the corner points are positioned using the current Federal standards and guidelines in place for geospatial positioning accuracy as it pertains to geodetic control networks referenced to the National Spatial Reference System or the equivalent, and any BLM supplemental accuracy standards and guidelines consistent with the Federal

Geographic Data Committee Standards for geospatial data. The positioning of corners should meet the defined minimum accuracy standards and guidelines adopted by the BLM when establishing corners based on their protracted latitude and longitude, independent of other corners within the protraction.

When establishing several adjacent corners in a single survey with surveyed lines between corners, for reporting geographic data on the plat at least two monuments will be established that meet the accuracy classification level for Federal Geographic Data Committee Standards. This will provide relative control for the other corners. The survey standards and guidelines or survey measurement methods prescribed will be specified in the special instructions. Any standards and guidelines should be consistent with the accuracy specifications of the technology used and the most current specifications generally accepted by the professional survey community.

(4) Latitude and longitude are shown only for section corners on the amended protraction diagrams. The latitude and longitude for any aliquot part corner within the protraction computed from the section corner values, lottings, and areas may be shown on the diagram.

(5) Aliquot part corners down to 1/1024<sup>th</sup> section corners may be established at their protracted latitude and longitude coordinate without reference to other corners where no areas are to be returned, except under the conditions specified in General Rule (4) herein. Where areas will be returned within a section, all four section corners will be monumented. Where controlling corners have been established and are within limits for rectangularity, corners will be established at proportionate distance or intersection as appropriate, not at the protracted latitude and longitude.

(6) Bearing and distance ties to previously established corners of the same section within the protraction are desirable and are required where new aliquot part corners are established along the line surveyed. Ties between section corners are not normally necessary unless corners are required along the line, in which

case rectangularity will be ensured and corners placed appropriately.

(7) Intersecting lines and random and true lines normally form the boundaries of protracted blocks. Once the protracted corner is established by latitude and longitude from which the intersecting line is to be initiated, the line will be surveyed on the protracted bearing to an intersection with the existing surveyed line, random and true line, or water boundary. In a like manner, random and true lines will be surveyed from the established protracted corner to the existing corner designated on the amended protraction diagram. Where rectangular limits can be achieved in intersecting a corner on the boundary of the protraction block, the intersected corner will control the alinement of the intersecting line (section 3-34). Where there is a large misclosure in the exterior boundary of the protraction, it may be necessary to modify the plan of survey to avoid poorly shaped parcels.

(8) When surveyed, a protracted block will normally become a section containing the regular aliquot parts with the excess or deficiency against the previously surveyed boundary.

(9) When portions of the unsurveyed protracted areas are surveyed, it may not be necessary to create a new amended protraction diagram for the remaining unsurveyed areas. Since there will normally be no changes in the protracted latitude and longitude of other corners in the protraction, an appropriate notation to this effect on the amended protraction diagram is sufficient.

(10) In some cases, local or administrative surveys have been performed within the protracted area, prior to the official survey, to locate and mark lease boundaries, administrative boundaries, the extent of mineral interests, or to segregate meanderable water bodies for acreage chargeability. Positions established by these surveys have no official standing but, at the discretion of the appropriate BLM Chief Cadastral Surveyor, should be accepted as corner positions when they are in substantial conformity with the amended protraction diagram.

## Meandering

**3-158.** This discussion on meandering pertains to original surveys and new meanders. Meandering pertaining to resurveys and associated water boundaries are discussed in chapter VIII.

**3-159.** The traverse that approximates the margin of a permanent natural body of water, e.g., the bank of a stream, lake, or tidewater, is termed a meander line. Numerous decisions in the United States Supreme Court assert the principle that, in original surveys, meander lines are run, not as boundaries of the parcel, but (1) for the purposes of ascertaining the quantity of land remaining after segregation of the bed of the water body from the adjoining upland, (2) for defining the sinuosities of the water body for platting purposes, and (3) for closing the survey to allow for acreage calculations. The ordinary high water mark (OHWM), or line of mean high tide (line of MHT) of the stream, or other body of water, and not the meander line as actually run on the ground, is the actual boundary.

**3-160.** Properly executed meanders create certain riparian rights in the upland parcel. Chief among these rights is that ownership of the upland follows subsequent lateral change in location of the bed through slow and imperceptible processes, such as accretion, erosion, and reliction. When by action of water the bed of the body of water changes, the OHWM changes, and the ownership of adjoining land progresses with it (*Lane v. United States*, 274 F. 290 (5<sup>th</sup> Cir. 1921); *aff'd*. 260 U.S. 662 (1923)).

**3-161.** Meander lines will not be established at the segregation line between upland and swamp or overflowed land, but rather at the OHWM or line of MHT between the swamp or overflowed lands and the water body. Meanders between the swamp or overflowed lands and the upland are a common source of errors in older original surveys (section 3-211).

### Ordinary High Water Mark and Line of Mean High Tide

**3-162.** All lands beneath navigable waters and other important rivers and lakes are to be segregated from the upland. Meanders are run along the OHWM for inland waters, and along the line of MHT for tidewater.

The general rule is that when the Federal Government conveys title to a lot fronting on a navigable body of

water, it conveys title to the water's edge, meaning the OHWM or line of MHT. Such riparian boundaries are ambulatory, not fixed in position. When an exception to the general rule is shown, the consequence is that the meander line becomes fixed and can become a fixed and limiting property boundary. Meander lines may be held fixed because of (1) an avulsive change, (2) gross error or fraud, (3) substantial accretion after survey but before entry, or (4) where the facts and circumstances disclose an intention to limit a grant or conveyance to the actual traverse lines. But the mere fact that an irregular or sinuous line must be run, as in the case of a reservation boundary, does not entitle it to be called a meander line except where it closely follows the bank of a stream, lake or tidewater.

**3-163.** Practically all inland bodies of water pass through an annual cycle of changes and multiyear cycles of drought and wet years. The OHWM is found between these extremes. In regions of broken topography, especially when bodies of water are bounded by sharply sloping lands, the horizontal distance between the margins of the various water elevations is comparatively slight, and the surveyor does not experience much difficulty in determining the horizontal position of the OHWM. However, where the meanderable bodies of water are bordered by relatively flat lands, the horizontal distance between the successive levels can be significant and the proper line difficult to measure.

**3-164.** For inland waters, the OHWM normally used is the line below which the water impresses on the soil by covering it for sufficient periods to deprive it of terrestrial vegetation, and the soil loses its value for agriculture, including grazing of livestock. Terrestrial vegetation is to be distinguished from aquatic and wetland vegetation in that the same vegetation can be found at higher and drier sites. At this level a definite escarpment, and often a change in character in the soil, is generally traceable, at the top of which is the true position for the meander line. A pronounced escarpment, the result of the action of storm and flood waters is often found above the principal water level and is separated from the OHWM by the storm or flood beach.

**3-165.** Some areas of riverbank or lakeshore lack vegetation of any kind or escarpments that can be used to identify the OHWM for use in meandering. In those situations, an identifiable OHWM is identified between sites where vegetation capable of identification exists on either side of the barren area. Reliance on elevations to extend a continuous line projected on the bank that

is parallel in height to the water surface of the river or lake is a common method.

**3-166.** The ordinary low-water mark is the point to which nontidal waters recede, under ordinary conditions, at their lowest stage. It is usually identified by a shelf in the bank. The shore is the space between the margin of the water at the ordinary low water mark and the OHWM (*Alabama v. Georgia*, 64 U.S. 505 (1859)).

### *The Vegetation Examination*

**3-167.** The vegetation examination is conducted in the field to determine whether the grass, tree, shrub, or plant is aquatic or terrestrial vegetation.

Aquatic vegetation is any one of a variety of plants that must grow in water; they are obligated to grow with their roots in water. Many aquatic plants have hollow stems so as to stand upright in still water and others have floats in order to stay on the water surface. If a given plant is not found higher up on the bank, it is probably an aquatic species.

Transitional species, such as buttonwood, water oak, or cypress, are upland or terrestrial species that exist in very wet environments. There have been claims that cypress trees are aquatic plants. A number of court cases have used cypress as an upland indicator of the OHWM, however a mature cypress may no longer be a good indicator of OHWM.

Terrestrial vegetation is distinguished from aquatic vegetation by the location in which it grows. If vegetation type "A" is found along the water's edge—or even in the water—and type "B" is also found growing at sites situated more toward higher, drier ground (upland), then "A" is a terrestrial species. A good rule of thumb is to determine if the plant is part of a self-reproducing stand of woody vegetation and not a seasonal plant that can sprout and mature in the few months when the water is unseasonably low. Trees, shrubs, and other woody-stemmed plants are generally terrestrial.

A small pocket of an aquatic type plant growing in low places not in the riverbed is also not an indicator of the OHWM and does not indicate that the OHWM should be moved toward upland to include that pocket of aquatics. It is the most water-ward location of the terrestrial species that is determinative. A small pocket of terrestrial vegetation at a small area near the water's edge, for example, may be enough to identify that area as being a part of the upland.



Care must be taken with the evaluation of nonnative invasive species, because when introduced they can change or fix the previous natural indicators of the OHWM.

### *The Soils Examination*

**3-168.** The soils examination is the next complementary examination. The leading court opinions regarding OHWM with reference to soils did not rely on or intend the use of laboratory tests of soils for this purpose. Accordingly, when a court decision dated before the 1940s refers to the character of the soil, it usually refers to the presence and shape of banks on rivers, shelving along lake shores, presence of sandbars and gravel bars, and other physical forms or manifestations of soil.

Extended inspection along a river boundary will usually result in some sort of correlation between the types of vegetation and the presence of banks or natural levees. The tests for vegetation and the test for soils can thus become complementary.

It is sometimes difficult to find a defensible OHWM because of conflicting evidence. When that occurs it is necessary to go upstream or downstream to locate another bank or banks where the OHWM is clear and convincing using vegetation and soils and then correlate that height of the OHWM above the surface of the flowing water in the difficult location.

Also a chemical soil test could be used provided that it is definitive. Soils that have been submerged for a long period of time are chemically different from upland soils, so it is important to establish the time period when that soil's particular chemical properties developed. Flooding that created a particular soil formation centuries before the original survey and grant should have no bearing on a present-day OHWM determination.

### *The Litter Examination*

**3-169.** Litter is the rubbish, twigs, and other floatable material found in a rough alinement at the reach of the highest waves that wash up on the shore. Logs and stumps generally do not wash up along the litter line. They are usually stranded below and toward the water from the litter line.

The litter line along a river boundary is mostly parallel and higher in elevation than the OHWM determined by the vegetation and soils test. On a lake shore, particularly, the presence of litter may correlate with the other tests and be useful for OHWM determination. The

presence of litter does not indicate the OHWM directly. Instead, the height of the litter above the water surface may be useful in correlating the OHWMs along the bank or shoreline.

### *The Agricultural Test*

**3-170.** The agricultural test is another complementary test. The items to consider include cattle or sheep raising, mowing of wild hay or collection of wild rice, and the raising of typical crops of the region, including grains or tubers. In essence, the agriculture test is simply a vegetation test that is restricted to valuable crops.

**3-171.** For tidal waters, the shore, also called the tideland, is the space between the line of mean lower low tide and the line of MHT (section 3-204). For tidal water, in the interest of certainty, the line of MHT is the average elevation of all the high tides occurring over a period of 18.6 years. Because it is based on elevations, meanders along the tidelands are run either by reference to tide gages and their reported elevations or by observation of physical conditions abutting the shore. Special instructions will provide guidance in selecting the method to be used.

**3-172.** Individual States may develop their own rules for determination of their own boundaries as against private owners but such State laws cannot generally act to reduce Federally owned areas or otherwise alter the boundaries of Federal land.

See Chapter III Notes for case studies on placement of the OHWM.

### *Meanders*

**3-173.** A meander corner is established at every point where a standard, township, or section line or special survey boundary intersects the OHWM of a navigable stream or other meanderable body of water. For tidal waters, the meander corner is established at the intersection of the surveyed line with the line of MHT. Meander corners are a controlling monument on the surveyed line and shall be treated similarly to other regularly established monuments such as section or quarter-section corners and tract corners for dependent resurvey purposes.

**3-174.** A "special meander corner" (SMC) is established at the intersection of the OHWM or line of MHT with a run and marked subdivision-of-section line. "Auxiliary meander corners" (AMC) are used



where there is no intersection of a surveyed line with the OHWM or line of MHT, as in the case of a meanderable lake found completely within a section not requiring subdivision. Auxiliary meander corners are also established at the intersection of avulsed lands with riparian lands, at the intersection of omitted land parcels with riparian lands, at the intersection between fixed and limiting original meanders and the current meanders, on the meander line of a previously unsurveyed island not intersected by a surveyed line, and at other intersections of riparian boundaries where use of a special meander corner is not appropriate.

**3-175.** No monument should be placed in a position exposed to the beating of waves and the action of ice in severe weather. In such cases a witness corner should be established at a secure point near the true point for the meander corner. The distance across the body of water, from the true point, is ascertained and reported in the survey record.

**3-176.** It is not practicable in public land surveys to meander in such a way as to follow and reproduce all the minute windings of the ordinary high-water mark, even though technology allows for a much more precise location at the time of the survey. The United States Supreme Court has given the principles governing the use and purpose of meandering shores in its decision in a noted case as follows:

Meander lines are run in surveying fractional portions of the public lands bordering upon navigable rivers, not as boundaries of the tract, but for the purpose of defining the sinuosities of the banks of the stream, and as the means of ascertaining the quantity of land in the fraction subject to sale, and which is to be paid for by the purchaser.

In preparing the official plat from the field notes, the meander line is represented as the border line of the stream, and shows, to a demonstration, that the watercourse, and not the meander line, as actually run on the land, is the boundary (*Railroad Co. v. Schurmeier*, 74 U.S. 272 (1868)).

There is no requirement that the meander line very closely approximate the OHWM such that every small indentation and projection is depicted by angle (often called meander) points on the traverse. An excessive number of angle points are not necessary as the true riparian boundary constantly changes through the

processes of accretion and erosion. The intent is to show the general configuration of the water line. As a result, it is expected that when choosing the angle points, the meander courses may cross either water or land during the process to minimize the number of angle points. Effort should be made to balance the amount of water and land crossed to return accurate acreage.

Depending upon the terrain, meander courses may be as short as a chain or as long as twenty chains or longer. Meander lines may be surveyed by any reliable method of measurement that can determine bearing and distance or coordinates that may be mathematically converted to courses. The angle points along the traverse are not normally monumented.

**3-177.** Meanders are reported as a traverse from the beginning meander corner to the ending meander corner. The traverse is comprised of a series of meander courses running between angle points. These meander points are chosen at obvious breaks in the shoreline at the OHWM, line of MHT, or other required riparian line. Whether the angle points are measured by traditional traverse methods or by individual coordinate determination is immaterial.

The surveyor commences at one of the meander corners, follows the OHWM, and determines the length and true bearing of each course, from the beginning to the next meander corner. For tidal waters, the surveyor follows the line of MHT. All meander courses refer to the true meridian and are determined to the accuracy outlined in this Manual or, if more accuracy is necessary, as outlined in the special instructions.

**3-178.** The survey record of meanders shows the corner from which the meanders commenced, the true bearing and horizontal distance of each course, and the corner upon which the last course closed. The meanders may be reported in a separate section of the field notes segregated by section or tract. Meander line field notes may be placed on the plat.

**3-179.** The following items will be noted along the meander line in the field notes or on the plat: (1) all streams flowing into a river, lake, ocean, or meanderable bayou, with the width at their mouths and their course; (2) the position, size, and depth of springs, and whether the water is pure or mineral; (3) the heads and mouths of all bayous; (4) all islands, rapids, and bars, with intersections to the upper and lower ends; (5) the height of the banks of lakes, streams, and tidelands, the

height of falls and cascades, and the length and fall of rapids; and (6) artificial structures and other notables such as improvements in both land and water areas. Except for original survey meander lines, the above items may be noted when administratively necessary.

**3-180.** Where it is impossible or impracticable to measure the meander line along the required riparian line due to physical impossibility, safety or cost, the official survey record will state the true location, noting the offset from the line measured.

**3-181.** Whenever the Secretary surveys lands selected by an Alaska Native, an Alaska Native Corporation, or the State of Alaska pursuant to the ANCSA, the Alaska Statehood Act, or the Alaska National Interest Lands Conservation Act (ANILCA), lakes, rivers, and streams shall be meandered in accordance with the principles in the 1973 edition of the Manual (43 U.S.C. 1631(a)(1)). Navigability investigations in Alaska are described in section 8-56.

### Rivers and Tidewater

**3-182.** Facing downstream, the bank on the left hand is termed the left bank and that on the right hand the right bank. These terms will be universally used to distinguish the two banks of a river or stream.

Navigable rivers and bayous are meandered on both banks, at the ordinary high-water mark, by taking the general courses and distances of their sinuosities for that portion that is navigable. For rivers classed as nonnavigable, when duly authorized, the bed acreage is segregated where the average right-angle width is 3 chains and upwards. This width is chosen as a practical guideline to balance the cost of meandering all rivers against the value of the excluded acreage.

**3-183.** In selected lands in Alaska, by law, all non-navigable inland rivers where the average right-angle width is 3 chains and upwards are meandered on both banks, at the ordinary high-water mark (43 U.S.C. 1631).

**3-184.** Tidewater streams, inlets, and bayous are meandered at the line of MHT up to the point of tidal influence or where they still allow free travel by customary watercraft, whichever is farther downstream. Tidewater inlets and bayous are meandered, when duly authorized, where the average right-angle width is 3 chains and upwards, and they no longer allow free travel by customary watercraft. Oceans, gulfs, bays,

bayous, straits, and other tidally influenced waters are meandered at the line of MHT.

### Lakes

**3-185.** All navigable lakes are meandered. Nonnavigable lakes are not meandered except for lakes of the area of 50 acres and greater when duly authorized. However, in selected lands in Alaska, non-navigable lakes of the area of 50 acres and greater are meandered, but the area of such nonnavigable lakes is nonchargeable area (43 U.S.C. 1631).

**3-186.** Exceptions to the general size rule are shallow or poorly defined “lakes” that are actually pools that collect because of permafrost and lack of drainage or are seasonal. These “lakes” will not be meandered even when larger than 50 acres.

**3-187.** In the case of meanderable lakes that are located entirely within the boundaries of a section, a quarter-section line, if one crosses the lake, is run from opposite quarter-section corners. At intersection with the OHWM, one or more special meander corners are established, and the course and distances recorded.

If a meanderable lake is located entirely within a quarter-section, and if, during the subdivision of the quarter-section, a quarter-quarter section line crosses the lake at intersection(s) of the line with the OHWM, a special meander corner or corners are established and the course and distances recorded.

**3-188.** If a meanderable lake is found to be located entirely within the boundaries of a section and it is impracticable to run a subdivision-of-section line across the lake, an “auxiliary meander corner” is established at some suitable point on the OHWM and a connecting line is run from the monument to a regular corner on the section boundary. The course and length of the direct connecting line are shown on the plat of the survey.

**3-189.** The meander line of a lake lying within a section is initiated at the established special or auxiliary meander corner, as the case may be, and continued around the margin of the lake at its OHWM, to a closing at the point of beginning. All proceedings are fully entered in the official record. When the section is not monumented, a connecting line is run from the auxiliary meander corner to a suitable monumented point within the township. If there are numerous lakes within the township, and showing the connecting lines

will clutter the plat, the lines need not be shown on the plat.

**3-190.** Artificial lakes and reservoirs are not segregated from the Federal interest lands, unless specifically provided for in the special instructions, but the true position and extent of such bodies of water are determined in the field and shown on the plat.

### Islands and Sandbars

**3-191.** For official survey purposes, an island is defined as a body of upland that is completely surrounded by water when the water is at the OHWM for inland waters or at the line of MHT for tidal waters. In those States that recognize the low water mark as the boundary and where State law appropriately serves as the source of law for the question, the water at low water mark may be the height of water defining the body of upland.

**3-192.** A gravel bar or sandbar is a formation of soil on the bed of a lake or river that rise above the OHWM but consists of loose and unconsolidated material considered liable to be washed away during subsequent high water seasons and, most important, is devoid of woody vegetation.

Islands form in rivers by several different processes as follows:

- (1) By deposit of alluvial material onto the bed of the river during high flow events that consolidates and supports terrestrial vegetation;
- (2) By the river cutting across a vegetated point bar;
- (3) By an avulsive change where a new channel is washed out around an existing area of upland;
- (4) By marked scour of the river bed around a submerged area; and/or
- (5) By the result of human activity in the river.

**3-193.** Every island above the OHWM of any meanderable body of inland water or above the line of MHT of tidal water, except islands formed in navigable bodies of water after the date of the admission of a State into the Union, is locatable by survey and should be meandered and shown on the official plat.

**3-194.** All islands will be meandered if practicable. In passing islands not to be meandered, estimated ties to their upper and lower ends will be reported to establish their location. Such islands are to be exhibited on the plat as accurately as practicable.

**3-195.** Even though the United States has parted with its title to the adjoining mainland, an island in a meandered body of water, navigable or nonnavigable, in continuous existence since the date of admission of the State into the Union and omitted from the original survey, remains as unsurveyed public land of the United States. As such, the island is subject to survey. Such islands were not a part of the bed at the date of statehood, and therefore their title remained in the United States, subject to survey and disposal when identified. The right that attaches to the riparian parcels along the meander line of the mainland pertains only to the bed of the water body, to access to the water, and to such islands in nonnavigable water bodies formed within the bed subsequent to the disposal of the title (sections 8-158 through 8-165).

If the patent conveyed these lands to the State we are not concerned with their subsequent disposal, for that is a question of local law. But did the patent include them? This, of course, is a Federal question. *Francis Levee District*, 232 U.S. 186, 196 (1914); *United States v. Oregon*, No. 13, original, 295 U.S. 1, 27 (1935).

Whether an island in a meandered nonnavigable water body is subject to survey after the United States has parted with its title to the adjoining mainland has been subject to inquiry. The U.S. Supreme Court rulings on the subject, however, have consistently held that Federal law governs the intent and whether lands were conveyed or remain Federal, subject to survey.<sup>1</sup>

<sup>1</sup> The Supreme Court in *State of California, ex rel. State Lands Commission v. United States*, 457 U.S. 273 (1982), held that whenever the United States has a claim to unsurveyed lands then Federal law will apply. State law should only apply when the dispute is between private parties see *Oregon ex rel. State Land Board v. Corvallis Sand & Gravel Co.*, 429 U.S. 363 (1977). Without reference to the Supreme Court decision in *State of California, ex rel. State Lands Commission* supra, two circuit courts have reached two different conclusions, first in *Koch v. United States*, 47 F. 3d 1015 (10<sup>th</sup> Cir. 1995) the court held that unsurveyed islands in nonnavigable water passed to the littoral owner under State law as a portion of the bed of the nonnavigable water. In *Wolff v. United States*, 967 F. 2d 222 (6<sup>th</sup> Cir. 1992), the Court held that State law would determine what was intended to be conveyed by the Federal government and if the intent of the Federal grant is unclear then State law will control the title to unsurveyed islands regardless of the navigable character of the water. However, Article IV, Section III, Clause 2 of the United States Constitution provides that Congress will make the rules concerning disposition of Federal lands.

**3-196.** The proof of the time of formation of islands is often difficult. It is the practice to make a careful examination of the history of an island in relation to the question of its legal ownership. Proof of island formation prior to the date of statehood is most readily presented in the form of historical maps and tree corings taken from the island that are accompanied by a professional correlation of the tree ring counts to the age-dating of the trees presently growing on the island.

Other means of presenting evidence of the age of islands comes from:

- (1) the presence of fire pits correlated with prehistoric Indian dwellings;
- (2) measurement of certain species of lichen diameters found on the island and correlated to similar lichens on datable grave markers, bridges or other structures of known date of construction;
- (3) lead cesium dating of mollusks;
- (4) identification of spores and pollen from introduced species whose date of introduction can be determined; identification of carbon layers from recorded fires; and
- (5) overlays from historic records capable of showing the rate of changes in island configuration.

**3-197.** Islands that have been given well-known proper names are so identified, both in the field notes and on the plat. Sometimes there are a number of islands in the same section without proper names. Their identification can be uncertain unless the following rule is applied:

Where there are several unnamed islands within the same section, these will be referred to in the official record (when surveyed) according to the lot number (Island designated as lot No.   ) that is assigned on the plat, excepting that islands that are crossed by section line boundaries, or by a centerline of the section, are readily identified by location.

**3-198.** The usual township, section, quarter-section, and meander corners are established on an island. Any township boundary or section line intersecting the island is extended as nearly in accordance with the plan

of regular surveys as conditions permit. If an island falls in two or more sections, the lines between the sections should be established in their proper theoretical positions based on suitable field methods.

If an island falls entirely in one section, and is large enough to be subdivided (over 50 acres in area), the subdivision is accomplished by the protraction of suitable subdivision-of-section lines in their correct theoretical position. A corner will be located at the intersection with the OHWM. At the point thus determined a “special meander corner” is established.

In the case of an island falling entirely in one section and too small to be subdivided, a suitable field determination is made to locate on the OHWM of the island an intersection with the theoretical position of any suitable subdivision-of-section line. At the point thus determined a “special meander corner” is established.

If an island falls entirely in one section and it is impracticable to locate an intersection with the OHWM with the theoretical position of any subdivision-of-section line, an “auxiliary meander corner” is established. The corner will be located at any suitable point on the island’s OHWM, and a connecting line run from the monument to any regular corner. The direct course and length of the connecting line is given in the field notes and shown on the plat.

**3-199.** Under special circumstances where administration or disposal requires no subdivision, an island is given a tract number within a township. In such cases, the section lines need not be extended to the island.

**3-200.** Agricultural upland within the limits of swamp and overflowed lands should be so classified and shown on the plat accordingly, but such land is not meandered as an island (section 3-211).

**3-201.** An unsurveyed island that was formed prior to statehood and found to be Federal interest land may be conveyed to States or their political subdivisions according to section 211(a) of the Federal Land Policy and Management Act (43 U.S.C. 1721(a)). Surveys intended for such islands will be conducted as if the island were to be patented to an individual and not conveyed without an official survey.

### Original Survey of Federal Lands along Tidelands

**3-202.** Tidelands are coastal areas situated above the line of mean lower low tide and below the line of MHT,



particularly as they are alternately uncovered and covered by the ebb and flow of the daily tides. As a part of the lands beneath navigable waters, such lands belong to the States by right of sovereignty (*Pollard's Lessee v. Hagan*, 44 U.S. 212 (1845)).

Tidelands are mentioned here to stress their distinction from swamp and overflowed lands. Coastal "salt marshes" that are covered by the daily tide are tidelands to be segregated and not subject to survey. On the other hand, coastal marshes that are not covered by the daily tide are swamp and overflowed lands within the meaning of the grants and are subject to survey.

**3-203.** Meander corners are established at the line of MHT along the margin of tidewaters. The sites selected for meander corners along the coastal margin are ideally at the point where the long continued presence and action of tide and surf has completely suppressed the growth of terrestrial vegetation through its effect on the plants and the soil, and in many locales, is identical with a point on the line of MHT.

For title purposes, along shorelines, the meander line is not a boundary; the actual boundary is the line of MHT, however for practical matters, the line of suppressed terrestrial vegetation suffices for acreage determinations of the upland (*Udall v. Oelschlaeger*, 389 F.2d 974 (D.C. Cir. 1968), *cert. denied*, 392 U.S. 909 (1968)).

Tidewaters are segregated from the upland by a meander line at the line of MHT. This meander line differs from the meander lines described for inland water bodies only in that it approximates the line of MHT rather than the OHWM of an inland river or lake.

### Offshore Islands and Offshore Rocks

**3-204.** Offshore islands and offshore rocks are those land forms lying offshore above the line of MHT. They may be identified as protracted blocks in a protraction diagram. They are to be located by auxiliary meander corners, special meander corners, or meander corners established on the line of MHT. Except in those States that have conveyed lands below the line of MHT, low-tide elevations are not located. The monumentation, ties, meandering, subdivision, and platting are the same as described for islands, except as noted.

Any township boundary or section line that will intersect an offshore island or offshore rock is extended as

nearly in accordance with the protraction diagram or plan of regular surveys as conditions permit, and the usual township, section, quarter-section, and meander corners are established. If one falls in two sections only, the line between the sections will be established in its proper theoretical position based on suitable field methods.

**3-205.** Auxiliary meander corners on offshore islands and rocks are to be connected to a regular public land survey system corner by a measured course and distance. Meanders are continued around the island or rock at the line of MHT or, in the case of an inaccessible rock, at an elevation equivalent to the line of MHT along the coast. Where numerous small isles, rocks, or pinnacles, essentially circular in configuration, need to be identified for purposes of extending jurisdiction, it is appropriate to establish an auxiliary or special meander corner at the center of mass and call for, as an example, a 15-foot diameter pinnacle, 30 feet high, without attempting to return meanders around the feature.

### Congressional Legislation Specific to Cadastral Survey Procedures in Alaska

**3-206.** All surveys of Federal interest lands in Alaska are to be conducted in accordance with the requirements of this Manual, except for variations of the requirements created by the Alaska Statehood Act, the ANCSA, the ANILCA, and other Congressional Acts specific to Alaska only, or except for specific contractual obligations approved under the survey authority of the Secretary to address special conditions in Alaska. Such variations, however, will be described in the special instructions and complied with during execution of the work.

The 1953 Submerged Lands Act, 67 Stat. L. 29; 43 U.S.C. 1301 et seq., is applicable to Alaska, and the State of Alaska has the same rights as other States to submerged lands within its borders (see 43 U.S.C. 1631(d) and section 6(m) of the Alaska Statehood Act, 79 Stat. L. 339, 343).

### Use of Remote Sensing Techniques

**3-207.** Where conditions are favorable, meander lines may be surveyed by the use of remote sensing techniques after the meander corners have been established in the regular manner. The official record will state what lines were so determined and all pertinent data regarding the technique.



## Swamp and Overflowed Lands

**3-208.** The acts of Congress that granted to certain States the swamp and overflowed lands within their respective boundaries were listed in section 1-17. Swamp and overflowed lands are also discussed in sections 3-161, 3-200, and 3-202.

The grant of these lands is one *in praesenti* passing an inchoate title to the lands as of the date of the grant, but requiring identification of the lands by survey and selection or patent to render the legal title (*United States v. Byrne*, 291 F.3d 1056 (2002); *cert. denied*, *Aria v. United States*, 537 U.S. 1088 (2002)).

However, the rights of the State or grantees of the State are not defeated if the Government does not make the identification; the State or grantees of the State can identify the lands in any other appropriate mode (*Wright v. Roseberry*, 121 U.S. 488 (1887)). When perfect title is vested, it relates back to the date of the grant. The lands are surveyed as public lands and subject to classification at that time. The character of the land is as of the date of the grant, not the date of survey. The United States did not retain the mineral estate to these lands.

In *San Francisco Savings Union, et al. v. Irwin*, 28 F. 708 (C.C.D. Cal. 1886), *aff'd*, *Irwin v. San Francisco Savings Union, et al.*, 136 U.S. 578 (1890), the Court stated:

The act of 1850 grants swamp *and* overflowed lands. Swamp lands, as distinguished from overflowed lands, may be considered such as require drainage to fit them for cultivation. Overflowed lands are those which are subject to such periodical or frequent overflows as to require levees or embankments to keep out the water, and render them suitable for cultivation.

**3-209.** Swamp lands include marshes and intermittent ponds that do not have effective natural drainage, such as to require drainage to fit them for cultivation, particularly where such conditions are long continued.

Overflowed lands are subject to such periodical or frequent overflows as to require levees or embankments to keep out the water and render them suitable for cultivation. Overflowed lands are different from “overflow lands.” The latter has reference to a temporary condition which may or may not exist at any given time. The former is in reference to a permanent condition.

**3-210.** It has already been emphasized in section 3-161 that meander lines will not be established between the upland and the swamp and overflowed lands. Riparian rights, which are applicable within the beds of lakes, streams, and tidal waters, are not enforceable across swamp and overflowed lands owned by another. In other words, the boundary between the ocean, lake, or river bed and the upland lies between that bed and the swamp and overflowed lands, not between the swamp and overflowed lands and the higher land. The survey of meander lines at the margin of swamps in the past has been a significant cause of the erroneous omission of lands from survey. Prior to the swamp and overflowed lands grants, these lands were generally not considered desirable by settlers and were often segregated from the upland by survey and platting.

**3-211.** The following rules should be followed in making surveys or field examinations of swamp and overflowed lands:

(1) According to 43 U.S.C. 984 (Rev. Stat. 2481), any legal subdivision, quarter-quarter section or comparable lot, shall be included in the category of swamp and overflowed lands if the greater part is “wet and unfit for cultivation.”

(2) “Wet and unfit for cultivation” is interpreted to mean that the land must have been so swampy or subject to overflow during the planting, growing, or harvesting season, in the majority of years at or near the date of the grant, as to be unfit for cultivation in any staple crop of the region in which it is located without the use of some artificial means of reclamation such as levee protection or drainage ditches.

(3) A subdivision that becomes swampy or overflowed at a season of the year when this condition does not interfere with the planting, cultivating, or harvesting of a crop at the proper time and by the ordinary methods is not “made unfit for cultivation” and does not qualify under the swamp land grant.

(4) Tame grass or hay, when produced by the ordinary methods of preparing the ground, is considered a staple crop, as well as the cereals, cotton, or tobacco.

(5) In the administration of the swamp acts, the States have been allowed optional methods

of preparing the lists of subdivisions that are to be identified as swamp and overflowed within the meaning of the acts. The surveyor must determine the position and extent of the swamp and overflowed land within the area under survey regardless of the methods employed by the States in asserting claims.

(6) Alabama, Indiana, Louisiana, Michigan, Minnesota (excepting as to lands within the Indian reservations), Mississippi, Ohio, and Wisconsin have elected to base their swampland lists on the field note record. In these States it is imperative that the field notes include a specific list of the subdivisions each of which is more than 50 percent wet and unfit for cultivation, regarding such character as at the date of the passage of the granting act.

Arkansas, by the Act of April 29, 1898 (30 Stat. L. 367; 43 U.S.C. 991), relinquished all right, title, and interest to the remaining unappropriated swamp and overflowed lands within its boundaries.

(7) In California, under 43 U.S.C. 987 (Rev. Stat. 2488), the swampland lists are based upon the representations of the plat of survey, and in this State it is imperative that the plats correctly show the conditions in this respect. Many early swamp and overflowed segregation maps and surveys were conducted under State authority and examined by the United States Surveyor General. Where they were found to conform to the Manual and related survey rules, the Surveyor General constructed and approved township plats based upon these surveys. They were then forwarded to the Commissioner of the GLO for approval.

(8) The selection of swamp lands in Florida, Illinois, Iowa, Missouri, and Oregon, and in Indian reservations within Minnesota, is based upon investigations and reports by representatives of the State and of the BLM, but this does not set aside the Manual requirements for the usual complete showing of the character of the land.

**3-212.** It is always important to note any marked changes in the water level and drainage conditions of the region and to ascertain the situation as of the date of the granting act. It is desirable to secure the testimony

of persons who have known the lands for long periods. The most convincing evidence of the land's character at the date of the granting act is the older native timber, as the varieties reflect their site conditions with great certainty.

This line of investigation requires an inquiry into the habitat of the forest species that are found, particularly as to whether the usual range of the tree is within low wet ground, as for example the cypress, tupelo, sweet gum, water ash, water locust, and red bay of the southern latitudes, and the tamarack, white cedar, black spruce, swamp spruce, and black ash of the northern latitudes of the United States. The presence of any of the species named indicates the possibility of swamp land, and while conclusive with some of them, others of the species named have a wider range and may be found associated with upland varieties. If upland varieties are present the plain inference will be that the site conditions are that of upland, even though a forest species may favor moist rich soil.

**3-213.** When conducting an original survey of public lands, the surveyor must notify appropriate BLM land status officials by memorandum with a tabulation of the subdivisions classified as swamp and overflowed lands. Any indications of swamp and overflowed lands referred to in the official record shall be called to the attention of the Land Office at the time when the plats are transmitted to be filed in order that the notice will contain a statement to that effect. The showing made by the official record as to the swamp and overflowed or not swamp and overflowed character of the land can be overcome by proof by the State or other applicants.

**3-214.** The silence of the official record respecting the character of the land will be treated presumptively as a statement that the land is dry or not swamp and overflowed. In the States having a swamp land grant swamp and overflowed lands are the exception and not the rule. It is the practice in public surveys to make special notation of the swamp and overflowed lands rather than of the dry or nonswampy lands.

## Limits of Closure for Original Surveys

**3-215.** Under the general subjects of "township exteriors" (section 3-17) and "subdivision of townships" (section 3-51), certain definite limits were prescribed beyond which previously established surveys are

classed as “defective,” or where, in the case of new surveys, corrective steps are required. Such limits are referred to as the “rectangular limit.” A more general requirement known as the “error of closure” together with proper field procedures can be applied as a test of the accuracy of the alinement and measurement of all classes of lines embraced in any closed figure incident to the Federal land surveys. Corrective steps are required wherever this test discloses an error beyond the allowable limit.

The “error of closure” of a survey is defined in general terms as the ratio of the length of the line representing the equivalent of the errors in latitude and departure to the length of the perimeter of the figure constituting the survey. However, with due regard for the controlling coordinate governing lines of a rectangular survey, accuracy in latitude is not permitted to offset gross error in departure, or vice versa. A double test is therefore applied to United States rectangular surveys in place of the one expressed in general terms.

The “limit of closure” set for the public land surveys may now be expressed by the fraction  $1/2828$ , provided that the limit of closure in neither latitude nor departure exceeds  $1/4000$ . Where a survey qualifies under the latter limit, the former is bound to be satisfied. An accumulative error of 2 links per mile of perimeter, in either latitude or departure, will not be exceeded in an acceptable survey.

The latitudes and departures of a regular section will each close within 8 links; of a regular range or tier of sections, within 28 links; and of a regular township, within 48 links. The boundaries of each fractional section including irregular claim lines or meanders, or the meanders of an island or lake in the interior of a section, should close within a limit to be determined by the fraction  $1/4000$  for latitude or departure considered separately. The same rule applies to all broken or irregular boundaries. All closings will be computed in the field.

Stricter limits of closure or rectangular limits will be specified in the special instructions for classes of surveys where higher accuracy is indicated by the values involved.

**3-216.** The issues of “rectangular limits,” “limits of closure,” “accuracy standards,” and “correct plat representations,” individually or collectively can bear upon the dependability of the record direction and length of lines of older approved surveys. The question arises as to what

extent those values can be incorporated safely into new surveys. When terrain, land use, and other relevant factors are given due weight, good judgment determines the limits of tolerance for each given situation.

**3-217.** Instances occur where all original corners may be fully identified and in a good state of preservation, but the previously established lines present defective conditions that exceed current allowable limits. In such cases the retracements of the section boundaries necessary to determine the factors entering into the error of closure and to furnish suitable data for the calculation of the areas of the resulting units embraced in the survey will be reported to the designated official. If it is determined that additional retracements or dependent resurveys are necessary, these will be provided for by supplemental special instructions.

When a new survey does not close against the latest official record within the current limits of closure, either additional surveying of the record lines or another independent verification of the new measurement is necessary. Generally, new acreage will not be assigned to legal subdivisions that do not close within the current limits of closure.

## Marking Lines Between Corners

**3-218.** The survey is marked upon the ground in the following ways:

- (1) The regular corners of the Federal land surveys are marked by fixed official monuments as described in chapter IV.
- (2) The relationship to natural topographic features is recorded in the official record as described in chapter IX.
- (3) Where administratively required or requested, the locus of the lines can be marked upon forest trees by blazing and by hack marks (figures 3-52 and 3-53). In the case of resurveys in areas of mixed Federal and alienated lands, it may be necessary to restrict the blazing to trees on Federal land. The surveyor on the ground should apply good judgment in particular cases not covered by the special instructions. Where it has been determined that lines will be marked, the methods discussed here are intended to



Figure 3-52.

fix the locus of the lines permanently with the minimum environmental impact and maximum utility.

(4) Where administratively required or requested, whether forested or not, the lines are marked upon the ground by posts, posts with officially designated signs, tags, or other approved marking material.

**3-219.** A *blaze* is a smoothed surface cut upon a tree trunk at about breast height. The bark and a small amount of the live wood tissue are removed with an axe or other cutting tool, leaving a flat surface that forever brands the tree. The size of the blaze depends somewhat upon the size of the tree, but should not be made larger than the surface of the axe blade. A blaze 5 or 6 inches in height and from 2 to 4 inches in width is usually ample.

A *hack* is a horizontal notch cut well into the wood, also made at about breast height. Two hacks are cut to distinguish them from other, accidental marks. A vertical section of the finished hack marks resembles a double-V extending across a tree from 2 to 6 inches depending upon the diameter of the tree.

The blaze and hack mark are equally permanent, but so different in character that one mark should never be mistaken for the other. The difference becomes important when the line is retraced in later years.

Trees intersected by the line have two hacks or notches cut on each of the sides facing the line, without any other marks whatever. These are called line trees when the species, diameter and distance are reported in the



Figure 3-53. Hack marks on a line tree.

survey record. By past practice some surveys called these sight trees or station trees. A sufficient number of other trees standing within 50 links of the line, on either side of it, are blazed on two sides quartering toward the line, in order to render the line conspicuous and readily traced in either direction. The blazes are made opposite each other coinciding in direction with the line where the trees stand very near line and approaching nearer each other toward the line the farther the line passes from the blazed trees (figure 3-54).

The lines should be so well marked as to be readily followed and the blazes plain enough to leave recognizable scars as long as the trees stand. This can be accomplished by blazing just through the bark into the live wood tissue. The blazes should be narrow so that they will heal before decay begins, and special care should be taken not to loosen the cambium layer around the blaze, since this will prevent overgrowth.

**3-220.** Lines marked with posts and other markers to render the line conspicuous should be readily traceable in either direction. These lines should be especially well marked near ridges, creeks, within distances of 5 chains of corner monuments and within 2 chains of arteries of travel.

Blazing and posting are marked only with reference to the established true line. Where lines are run by the “random and true” line method, the marking of line is accomplished by returning over the line after all corrections or adjustments to the final line are definitely known. True line intersections with line trees will be made with precision, and distances thereto accurately measured.



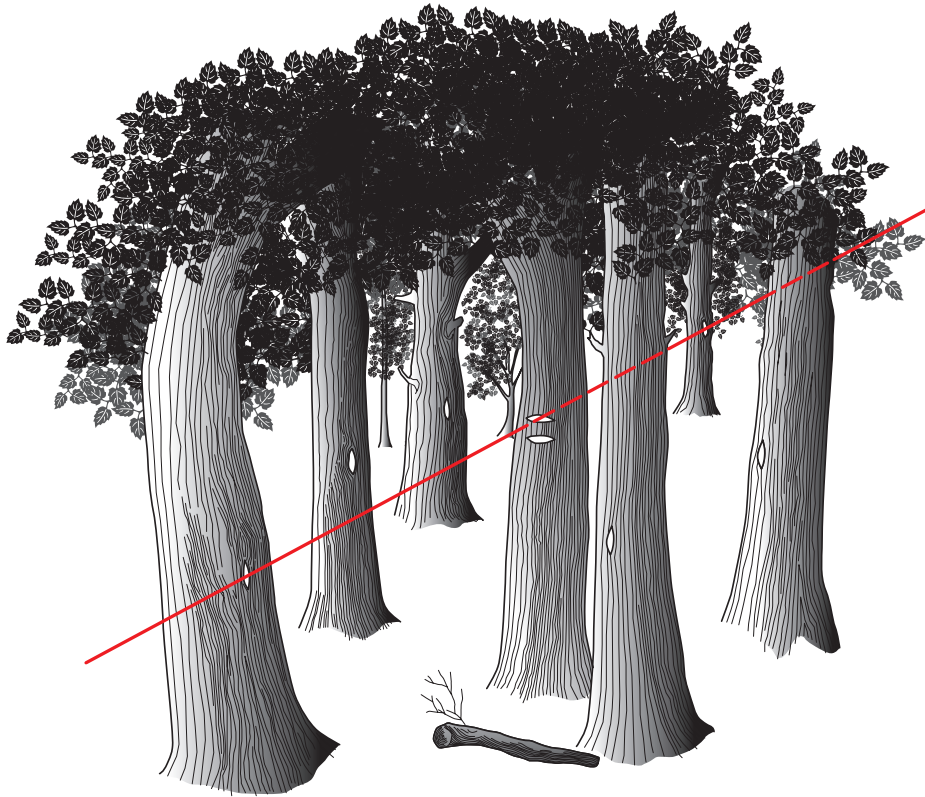


Figure 3-54. Marking a line through timber.

## Summary of Objects to be Noted and Sketches

### Official Record

**3-221.** The official record (field notes and plat) of a survey furnishes a technical record of the procedures used. It also serves as a report on information about connections showing the relation of the rectangular surveys to other surveys, to natural objects, and to improvements.

The connections can, through geodetic ties, provide the means of obtaining land information indirectly through the use of remote sensing, maps, or other sources. A triple purpose is thus served:

- (1) The technical procedure is made a matter of official record.
- (2) The purpose of the survey, along with general information relating to improvements, infrastructure, and land tenure, is incorporated with the survey results.
- (3) The positional relationships between the corners, and features and objects recorded

furnish important evidence by which the locus of the survey becomes practically unchangeable as contemplated by law.

**3-222.** Chapter IX and appendixes I through V provide minimum requirements for creating the official record for surveys. The specimen field notes and plats are intended to standardize the form of record. Special matters relating to these subjects are discussed in chapter IX. The technical and topographical features that are to be carefully observed and recorded in the field during the progress of the Federal interest land survey are:

- (1) The material of which corner monuments are constructed, their dimensions and markings, depth set in the ground, and their accessories.
- (2) The nature and material of construction of corner monuments that are found; condition; dimensions and markings; height above the ground; accessories; and a statement with respect to the known record, but if there is no known record, a statement to that effect.
- (3) The kind and diameter of bearing trees, the course and distance from their respective



corners, and the markings; all bearing objects and marks thereon, if any; and the position of witness corners relative to the true corners.

(4) The course and length of every line run, the method employed, and all necessary offsets therefrom.

(5) The form, location, and description of the evidence used and bearing upon items 1 thru 4.

(6) A complete description of ties to the National Spatial Reference System and related geodetic networks.

### Additional Information

**3-223.** In addition, the following information is furnished to the extent that it is administratively required for the proper management of the lands to be surveyed:

(1) Line trees. The species, diameter, and distance on line to trees that line intersects and their markings.

(2) Intersections by line of land objects. The distance at which the line intersects the boundary lines of a reservation, townsite, special survey, or private claim, noting the exact bearing of such boundary lines, and the distance to the nearest boundary corners in both directions; the right-of-way and center lines of a railroad, canal, ditch, electric transmission line, or other right-of-way, noting the bearing of the center line and the width of the right-of-way on line, if only the center is noted; and the change from one character of land to another, with the approximate bearing of the demarcation, and the ascents and descents over the principal slopes traversed, with the slope direction; the distance to and the direction of the principal ridges, spurs, divides, rimrock, precipitous cliffs, etc.; the distance to where the line enters or leaves timber, with the approximate bearing of the margin, and the distance to where the line enters or leaves dense undergrowth. The amount of ascent or descent is only required where it will be of significant value to later surveyors. The slope on which a corner is situated should be shown.

(3) Intersections by line of water objects. Unmeandered rivers, creeks, and smaller

watercourses that the line crosses; the distance measured on the true line to the center in the case of smaller streams and to both banks in the case of larger streams; the course downstream at points of intersection; and their widths on line, if only the center is noted. Intermittent watercourses, such as ravines, gulches, arroyos, draws, dry-drains, etc., with their downstream course.

(4) The land's surface; whether level, rolling, broken, hilly, or mountainous.

(5) The soil; whether rocky, stony, gravelly, sandy, loam, clay, etc.

(6) Timber and its density; the several kinds of timber and undergrowth, in the order in which they predominate.

(7) Bottom lands to be described as upland or swamp and overflowed, as contradistinguished under the law, noting the extent and approximate position of the latter and depth of overflow at seasonal periods. The segregation of bottom lands fit for cultivation without artificial drainage, from the swamp and overflowed lands, where the latter are subject to selection by the States, is always accomplished by legal subdivision. Each of the smallest legal subdivision is classified as all upland or all swamp and overflowed land accordingly as more than half of the same is of the character of the one or of the other class of lands.

(8) Springs of water, whether fresh, saline, or mineral, with the course of the stream flowing therefrom. The location of streams, springs, or water-holes, which because of their environment may be of value in connection with the utilization of public grazing lands, and which may be designated as public watering places, will be specially noted.

(9) Lakes and ponds, describing their banks, tributaries and outlet, and whether the water is pure or stagnant, deep or shallow.

(10) Improvements; towns and villages; post offices; occupancy; houses or cabins, fields, or other improvements; mineral claims; millsites. United States location monuments and all other official monuments not belonging to the system of rectangular surveys to be located by bearing

and distance or by intersecting bearings from given points.

(11) Coal banks or beds, ore bodies, with description as to quality and extent; mining surface improvements and underground workings; and salt licks. Reliable information that can be obtained respecting these objects, whether on the line or not, should appear in the general description.

(12) Roads and trails, with descriptions and their directions, whence and whither.

(13) Rapids, cataracts, cascades, or falls of water, in their approximate position and estimated height of fall in feet.

(14) Stone quarries and ledges of rocks, with the kind of stone they afford.

(15) The magnetic declination, including the observed local attraction within the area of the survey. The average value over the area surveyed will be shown on the plat.

(16) The above information is summarized by township in a general description that concludes the field notes of every survey. The general description embraces more comprehensive details of the characteristics of the region than is feasible to cover as an intimate part of the technical record of the survey, as follows:

(a) Land: A general outline of the drainage and topographical features of the township and approximate range of elevation above sea level.

(b) Soil: The prevailing and characteristic soil types. (See special reference to soil classification, section 3-227).

(c) Timber: The predominant forest species, age, size, condition, etc.

(d) Evidence of mineral: Known bodies of mineral, and lands of a formation that suggests mineral-bearing characteristics, especially with reference to lands of volcanic or igneous origin, are listed by appropriate legal subdivision, with brief

description of the mineral indications. If there is no apparent indication of mineral deposits, a report to that effect is embodied in the general description.

(e) Watering places: The areas embracing all streams, springs, or water holes as may be of special value as public watering places, in connection with the utilization of public grazing lands, are listed by appropriate legal subdivision, with brief description of the nature of such water supply.

(f) Settlement: The extent of the settlement at the time of the survey.

(g) Industry: The industrial possibilities of the township, especially as to the adaptability of the region to agricultural pursuits, stock raising, lumbering, mining, recreation, or other profitable enterprise.

(h) Special: All exceptional steps in the technical process of the survey and other special matters not otherwise suitably recorded should be reported in the general description.

**3-224.** Natural curiosities, petrifications, fossils, organic remains, etc.; also all archaeological remains, such as cliff dwellings, mounds, fortifications, or objects of like nature will not generally be reported in a public record. Disclosure in the survey record of information about the location of a historic resource shall be withheld when disclosure may cause a significant invasion of privacy, risk harm to the historic resource, or impede the use of a traditional religious site by practitioners (16 U.S.C. 470w-3). The approving officer should make note of these items and report them to the affected surface managing agency according to the applicable directives and special instructions.

### Sketch Plat

**3-225.** In addition to the field notes the surveyor may be required to prepare an outline diagram showing the course and length of established lines with connections and a sketch embracing the features usually shown upon the official plat. If the area of the survey is covered by accurate maps or recent aerial photographs, topographic detail may be omitted from the sketch except in the immediate vicinity of the lines. The positions of the

details to be shown on the completed plat are located with an accuracy commensurate with their relative importance. The design of the specimen township plat should be followed closely in preparing the sketch plat. These sketches form the basis of the official plat, the ultimate purpose of which is a complete graphic representation of the public lands surveyed.

The subjects of the field sketches; accuracy of detail in special cases; use of aerial photographs; map features within the interior of sections; etc., are expanded upon in chapter IX.

## Soil Classification

**3-226.** Soil classification has been an invaluable aid in the development of the public domain, both to the prospective settler and in the administration of natural resources. Such information is now generally available from other sources, and its provision by the official record is not as important as it once was. Yet, in the making of original surveys, it is necessary to tie the available information to specifically described lands. Further, the general law (Rev. Stat. 2395; 43 U.S.C. 751(7)) requires the surveyor to note and report upon the soil types. These requirements will hereafter be limited to lands being surveyed for the first time and need not be routinely applied to resurveys unless provided for by the special instructions.

The soil types, when considered in relation to precipitation and other climatic factors, the drainage, the adaptability of the terrain to irrigation, the elevation, and the latitude, will indicate whether the highest and best use of the land is for farming, grazing, forestry, or other purposes.

**3-227.** An outline of the matters to be considered in soil studies is presented below as a guide to the surveyor in making his or her report:

- (1) Texture: Gravel, coarse and fine; sand, coarse and fine; sandy loam; silt loam; loam; clay, heavy and light; and muck.
- (2) Structure: Single grained, pulverulent, and lumpy.

(3) Color: Surface soil and subsoil, both when dry and when wet.

(4) Chemical properties: Acidity, alkalinity, and humus content.

(5) Depth: Surface soil and subsoil.

(6) Location: River bottom or flood plain, bench, slope, plateau, prairie, and mountain.

(7) Topography: Level, rolling, broken, hilly, and mountainous, and elevation above sea level.

(8) Drainage: Direction, depth to water table, and quality as poor, good, or erosive.

(9) Mode of formation: Water laid, glacier laid, wind laid, and residual.

(10) Geological derivation:

(a) Sedimentary rocks: Formed of fragments of other rock transported from their sources and deposited as conglomerate, sandstone, and shale; or formed by simple precipitation from solution, as limestone, or of secretions of organisms, as some coastal rocks.

(b) Metamorphic rocks: Formed through change in constitution, especially those due to great pressure, heat, and water, and resulting in a more compact or more highly crystalline condition, including, for example, quartzite, marble, slate, and schist.

(c) Igneous rocks: Formed through the action of intense heat, including, for example (first, eruptive rocks) basalt, lava, and volcanic ash; (second, trap rock) felsite and quart-porphry; and (third, granular rock) granite, diorite, and porphyry.

For additional information on important features of soils see *Soil Studies*, appendix VII, section 538, 1947 Manual.

# Chapter III Notes

The notes presented here are case studies that elaborate on or continue to discuss the topics presented in chapter III. The section numbers correspond to the section numbers in the chapter and are followed by "(n)" to indicate that they are additional notes. The case studies are used by permission from *River & Lake Boundaries* by James A. Simpson.

These case studies are provided as training tools, and must be viewed in their historical context. Please be aware that to the extent they refer to case law or legal analyses, such references have been provided in order to explain why certain surveys were conducted in the manner they were. Such case law may, however, have been subsequently superseded and/or may not be applicable outside the particular circumstances and timeframe of that case. Questions in this regard should be directed to the Office of the Solicitor.

## Ordinary High Water Mark (Case Studies)

**3-162(n) through 3-172(n).** The following case studies illustrate some of the various legal settings in which the OHWM is an issue. Surveyors need to be aware of these situations which may affect their resurvey work.

**Howard v. Ingersoll, 54 U.S. 381 (1852)**

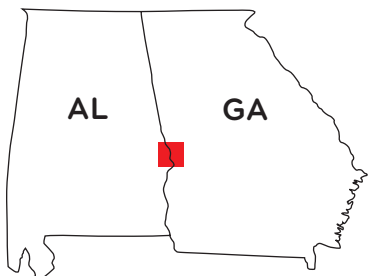


Figure 3-55. Vicinity map.

J. H. Howard of Columbus, Georgia, built a dam across the Chattahoochee River at a point above the head of usual navigation. The Chattahoochee River formed the boundary between Alabama and Georgia; the right/western (Alabama) bank of the river was defined as the State boundary (figure 3-56).

Georgia; the right/western (Alabama) bank of the river was defined as the State boundary (figure 3-56).

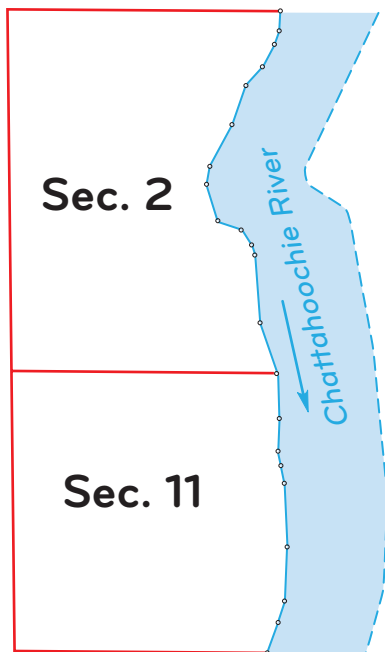


Figure 3-56. Portion of GLO plat of T. 17 N., R. 30 E., St. Stephens Meridian, Alabama, an 1833 survey by Josua Coffee.

As the water backed up it reached a grist mill owned by Stephen M. Ingersoll, a physician who owned land in

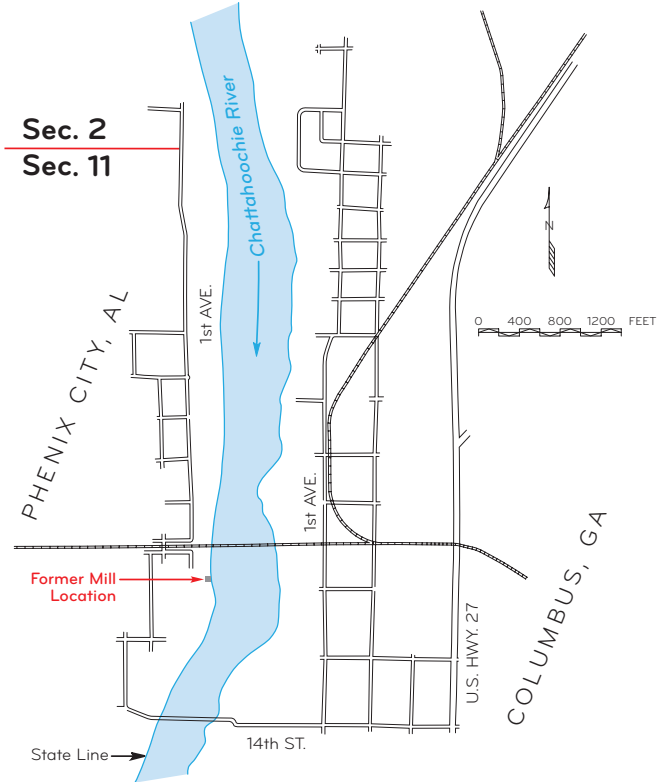


Figure 3-57. Sketch of Columbus and Phenix City showing the former grist mill location on the west bank of the Chattahoochee River.

Alabama down to the water’s edge. Because the raised water level in the river caused Ingersoll’s mill to cease functioning, Ingersoll sued in Alabama State Courts (figure 3-57).

The outcome of the case depended on the location of the boundary between Georgia and Alabama. The Alabama jury and Court found the State boundary to be at the ordinary low water mark of the left/east bank of the Chattahoochee and that Ingersoll had a right to operate his mill there. Verdict was given to Ingersoll.

Howard appealed and lost. Howard then brought another suit in the Circuit Court of the United States for the District of Georgia.

Eventually the case went to the Supreme Court of the United States. The Court’s opinion provided the foundation of the OHWM concept.

When the State of Georgia ceded its lands west of the Chattahoochee to the United States, Georgia kept the ownership of the bed of the river. The boundary was described as, “a line beginning on the western bank of the Chattahoochee River, running thence up the said River Chattahoochee, and along the western bank thereof” (p. 420).

If the State boundary was at the low water mark, Ingersoll was legally damaged by the change in water level. On the other hand if the boundary was the top of flood stage (height) on the far bank, Ingersoll had no rights at all.

Ingersoll’s mill was located on a small flat alongside the main river channel. At “ordinary high water” the flat where the mill was located was covered with water according to the evidence but at ordinary low water and extreme low water the mill was on dry ground. The dry situation lasted about one-third of the year. Evidence showed that the flat contained pine, oaks, gum and poplar trees. A small part of the flat had been cultivated and there was a cotton gin and a saw mill located there.

The bank at the mill itself was “never overflowed, even at the highest stages of the river, the water of which always remained several feet below it.” The river valley is contained by bluffs, which vary from 15 to 150 feet in height, and the bank was 15 to 20 feet in height immediately at the mill.

In some very general language, the majority opinion of the High Court was that Georgia’s jurisdiction extended to the “line which is washed by the water, wherever it covers the bed of the river within its banks. The permanent fast land bank is referred to as governing the line. From the lower edge of that bank, the bed of the river commences, and Georgia retained the bed of river from the lower edge of the bank on the west side. And where the bank is fairly marked by the water, that water level will show at all places where the line is.” (p. 418.)

There were almost no usable words of direction to a surveyor in the majority opinion. Justice Nelson in a dissenting opinion came a little closer. He wrote that the line was marked by the permanent bed of the river from the flow of the water at its usual and accustomed stage and where the water will be found at all times of the season except when diminished by drought or swollen by freshets (floods).

The often quoted language from this leading case was written in a different dissenting opinion by Justice Curtis:

That the banks of a river are those elevations of land which confine the waters when they rise out of the bed; and the bed is that soil so usually covered by water as to be distinguishable from the banks, by the character of the soil, or vegetation, or both, produced by the common presence and action of flowing water . . . . This line is to be found by examining the bed and banks, and ascertaining where the presence and action of water are so common and usual, and so long continued in all ordinary years, as to mark upon the soil of the bed a character distinct from that of the banks, in respect to vegetation, as well as in respect to the nature of the soil itself. (p. 427.)

But in all cases the bed of a river is a natural object, and is to be sought for, not merely by the application of any abstract rules, but as other natural objects are sought for and found, by the distinctive appearances they present; the banks being fast land, on which vegetation, appropriate to such land in the particular locality, grows wherever the bank is not too steep to permit such growth, and the bed being soil of a different character and having no vegetation, or only such as exists when commonly submerged in water. (p. 428.)

Finally, this was something that could be used in the field: The boundary was where the bank was formed and the upland vegetation ceased to grow.

The case was sent back to the Alabama Supreme Court and the Federal Circuit Court for further hearings using the OHWM as the boundary between the two States.

Ingersoll accordingly lost his case.

Until this day the entire control of the water power from dams along the Chattahoochee is concentrated on the Georgia side of the river.

The Ingersoll case is of interest today. Ingersoll is classed as a leading case so it is important to know what kinds of vegetation grew on the banks of the Chattahoochee River. Where did it grow in relation to the top of the bank and what were the soil conditions along those banks.

Conditions along the river may not be exactly the same as they were more than 150 years ago. Accordingly, we have to rely on historical information and any photographs that survived from those times and then correlate that with what is on the ground today.



Examination of the sketches and photographs above shows that there were shrubs and trees on the banks of the Chattahoochee River in the 1840s through the 1880s and that similar vegetation is growing in similar situations there today. Photographs of steamboats loading cotton from the mills in Columbus incidentally show shrubs and trees growing along the banks, and the growth extends down to the water showing at the time of the photograph.

An illustrator's drawing of a man fishing on the Alabama bank of the Chattahoochee River that shows small but mature trees and shrubs growing on the bank where the fisherman sits with his back to the artist.

There is not enough detail in the sketches and the photography to identify what species of shrub or trees are growing there but that specificity is not necessary to illustrate the intent and meaning of the *Howard v. Ingersoll* decision.

In 1850, the intent of the Supreme Court was very probably that the boundary was to be at the bank where an angler would stand to fish. It would be at a place where the bushes had ceased to grow, where the soil was firm enough to stand—specifically a bank. The Court very probably did not intend that the boundary be located at a point separated from the flowing water by a forest or a thicket even though that thicket or forest is greatly affected by the presence of the water of the river. Nor was the intended boundary located at the top of the high bank, which, in the case of the Chattahoochee, would be from 15 to 20 feet in height immediately at the plaintiff's lands and lots.

***Borough of Ford City v. United States*, 345 F.2d 645 (3<sup>rd</sup> Cir. 1965), cert. denied, 382 U.S. 902 (1965)**

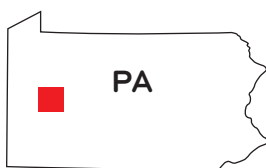


Figure 3-58. Vicinity map.

The sewage outlet for Ford City, Pennsylvania, was a pipeline emptying into the Allegheny River. When the Corps of Engineers built a lock and dam on the Allegheny downstream from Ford City,

it raised the level of the river such that the City was required to pump the effluent instead using gravity flow. The City also claimed that the higher levels increased ground water leakage into their sewers (figure 3-59).

The Allegheny was agreed to be a navigable river. For so long as the Corps' dam did not raise the water level above the OHWM in normal flow times, the United

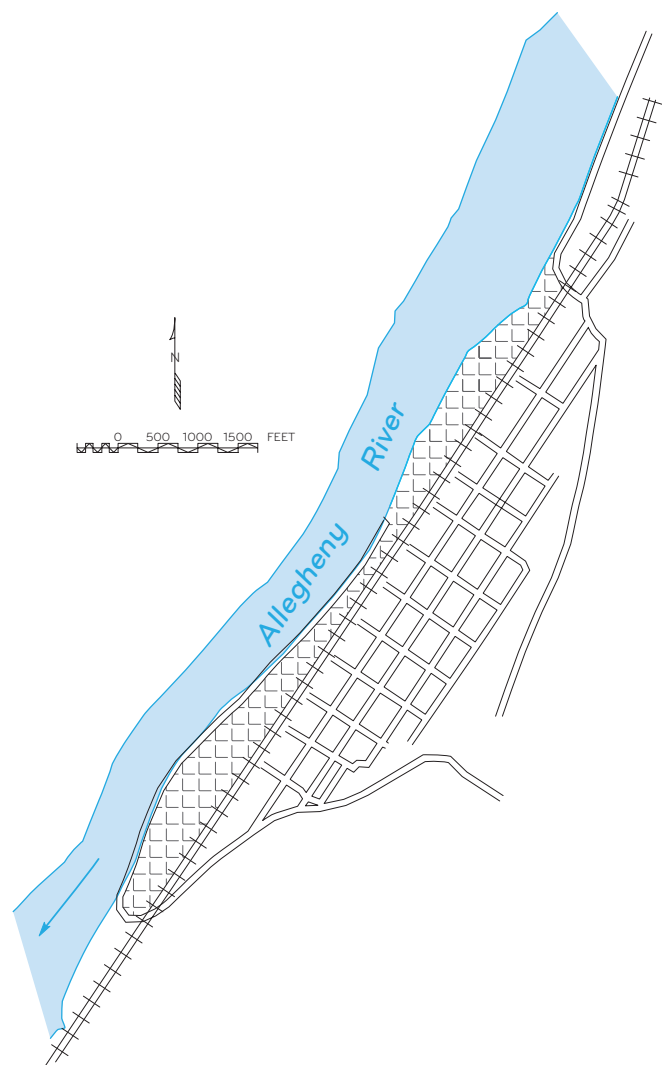


Figure 3-59. City of Ford City, Pennsylvania, from USGS maps.

States would not be liable. Property could be taken without compensation for navigational improvements but only below the OHWM.

The critical point of the trial became the elevation (or location) of the OHWM.

The District Court, 213 F.Supp. 248 (1963), held that the Government dam had raised the OHWM and the Government to be liable. That finding was based on a quotation from *U.S. v. Chicago B. & Q. R. Co.*, 90 F.2d 161 (1937), cert. denied, 302 U.S. 714 (1937), that: "The river bed is the land upon which the action of the water has been so constant as to destroy vegetation. It does not extend to nor include the soil upon which grasses, shrubs and trees grow." (p. 170, p. 251, and p. 647.)

The chief witness for the City of Ford City was a forester by training who admitted he had been engaged to make observations on the Allegheny River's bank vegetation.

He stated that his understanding of the law was that the vegetation was the controlling factor. The witness stated that he had found the line where the vegetation had ceased to grow to be at elevation 773.78 feet. His work was done after the dam was built and in operation.

From the District Court's findings of fact, it states the following:

In order to fix the location of the pre-dam ordinary high-water mark, it was necessary to determine the elevation of the existing ordinary high-water mark and translate it into the location of the pre-dam ordinary high-water mark. This was done by utilizing the amount of flow of water necessary to reach the present ordinary high water mark and by determining where this same amount of flow of water would come on the banks of the stream in open river conditions. (*Borough of Ford City v. United States*, 213 F.Supp. 248, 254 (W.D. Penn. 1963).)

The pre-dam ordinary high-water mark was thus 766.8 feet, using hydraulic computational estimates, according to the Ford City's witness.

Among the Government's witnesses, a botanist gave his opinion that below elevation 776.4 (the First St. Outlet) terrestrial plants would not grow, and there would be no value to the land for agricultural use.

A hydraulic engineer for the Government testified that the impress of the line of ordinary high water was at 776.5 and that pre-dam ordinary high water was at 771.4. The Government witnesses all made use of shelving, erosion and litter in substantiation of their findings. They also covered the entire pool area not just the Ford City vicinity.

The Appeals Court held that the District Court's Judge erred in accepting Ford City's forester's testimony, which was based solely on the destruction of vegetation and using that testimony as the basis for his ruling.

In *Harrison v. Fite*, 148 F. 781 (8<sup>th</sup> Cir. 1906), the Appeals Court said, held that the "bed of a river . . . is that soil so usually covered by water that it is wrested from vegetation and its value for agricultural purposes is destroyed." (p. 783 and p. 648.) The Appeals Court also quoted *Howard v. Ingersoll*, above, as well.

They summed up the subject with:

The value for agricultural purposes is destroyed where terrestrial plants not all plant life ceases

to grow. Just as definitely the same law is that the bed of such stream . . . does not extend to or include that upon which grasses, shrubs and trees grow though covered by the great annual rises. (p. 648, again quoting *Harrison v. Fite*, p. 783.)

From the Appellate decision:

The vegetation test is useful where there is no clear, natural line impressed on the bank. If there is a clear line, as shown by erosion, and other easily recognized characteristics such as shelving, change in the character of the soil, destruction of terrestrial vegetation, and litter, it determines the line of ordinary high-water (citations omitted). Also a test of the distinct line is the destruction of terrestrial vegetation so these are not really two separate tests but must, of necessity, complement each other. (p. 648.)

Another important Appellate conclusion: "If it is difficult to ascertain the line of ordinary high-water at this site, recourse may be had to other sites along the same stream to determine the line (citation omitted)." (p. 648.)

The Judgment against the Government was reversed.

***United States v. Claridge*, 279 F.Supp. 87 (D. Ariz. 1967), *aff'd*, 416 F.2d 933 (9<sup>th</sup> Cir. 1969), *cert. denied*, 397 U.S. 961 (1970)**



Figure 3-60. Vicinity map.

The United States sued for quiet title in District Court on land in sections 22, 27 and 28, T. 3 N., R. 22 W., Gila and Salt River Meridian, Arizona (figure 3-61) to lands along the Colorado River running between Arizona and California, claiming the land had been withdrawn from entry for reclamation purposes since 1902. Claridge held a quit-claim deed only. He had also occupied the disputed land by virtue of a prior land use permit acquired from the United States Lower Colorado River Land Use Office. He had spent considerable money preparing the land for farming and was growing crops.

Claridge claimed that the disputed land was below the OHWMs of the river because the spring floods ordinarily covered the valley "from bluff to bluff." Claridge

also asserted that the closure of Boulder Dam (Hoover Dam) about 200 miles upstream had artificially changed the river banks to their present condition (figure 3-61).

Arizona became a State in 1912 and at that time the disputed lands were within the bed of the Colorado River according to Claridge. Under the Submerged Lands Act of 1953 title to lands below the OHWM were confirmed to the State of Arizona as of 1912.

The State of Arizona joined the Claridge suit. Arizona stood to gain a very considerable area of prime farm lands up and down the river if Claridge's "bluff to bluff" theory were held to be correct.

The bluffs on the Arizona side are in the immediate vicinity of the Claridge lands. On the California side the bluffs are more than 8 miles away. The river approaches the west side of this flood plain in other places so that Arizona would benefit there also (figures 3-62 and 3-63).

The Arizona Land Department had leased the land to Claridge as if it were river bed.

The Courts found the OHWM to be a "natural physical characteristic placed upon the lands by the action of the

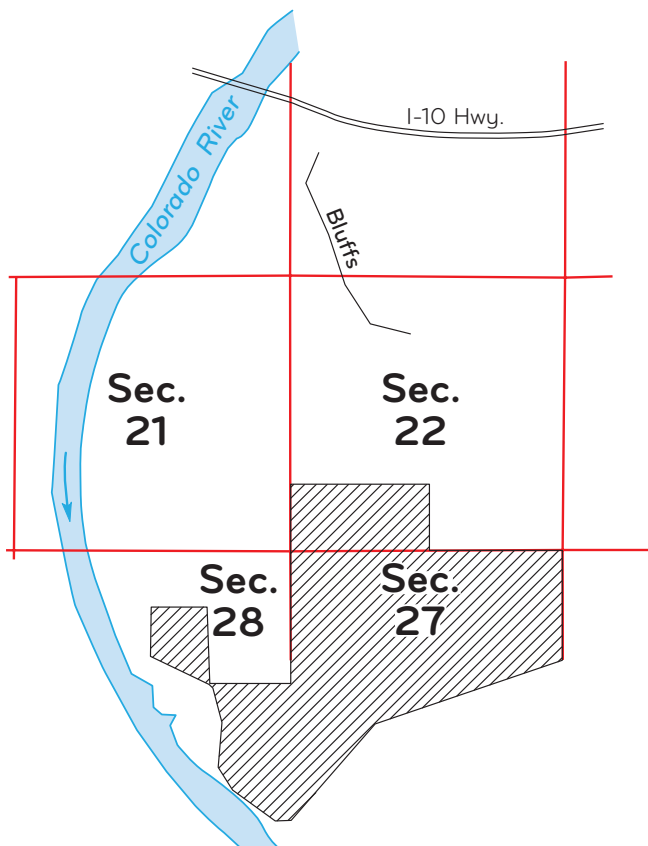


Figure 3-61. The Colorado River had been channelized at the time of the Claridge suit (taken from a 1976 USGS quad).

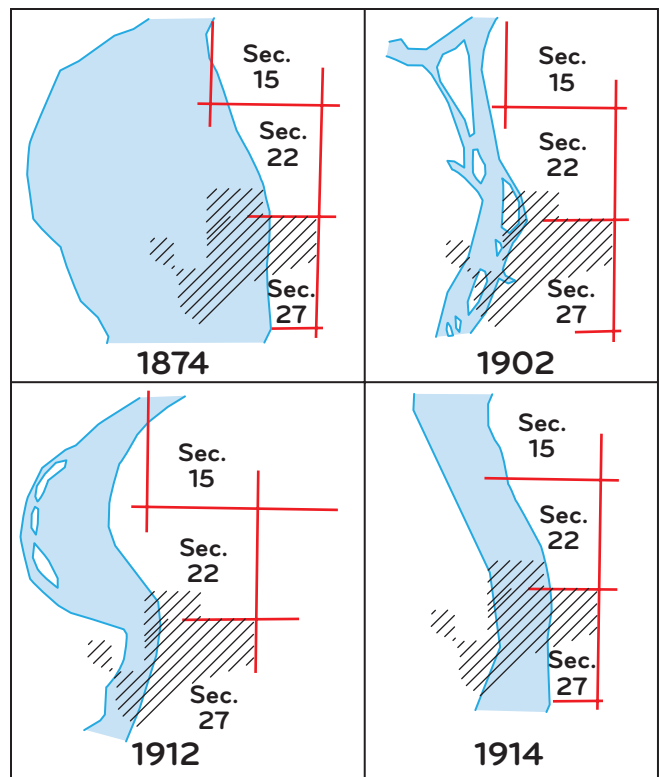


Figure 3-62. Changes in the Colorado River from 1874 to 1914.

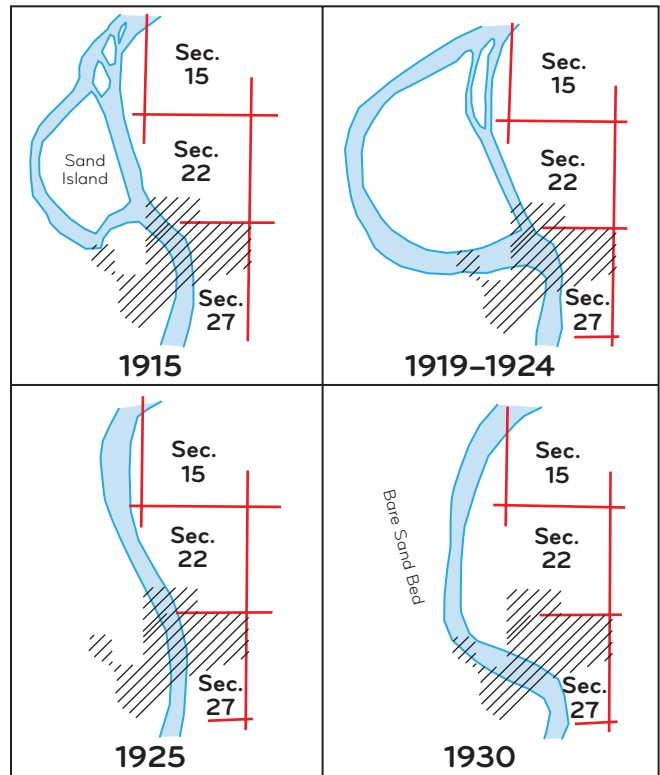


Figure 3-63. Changes in the Colorado River from 1915 to 1930.

river. It is placed there, as the name implies, from the ordinary flow of the river and does not extend to the peak flow or flood stage so as to include overflow on the

flood plain, nor is it confined to the lowest stages of the river flow.” (p. 934; quoting *United States v. Claridge*, 279 F.Supp. 87, 91 (D. Ariz. 1966).)

From this finding the Courts went on to say that Arizona was mistaken in assuming that the ordinary high water before the closure of Hoover Dam extended from bluff to bluff. The fact that the dam eliminated the extensive floods was not found to be an avulsive change. The lands in question were Federal.

Claridge appealed the ruling to the Supreme Court of the United States but certiorari was denied so the ruling stands as an important case in the Federal courts.

***Zunamon v. United States*, Ct. Cl. Docket # 80-78**  
(Slip opinion filed June 23, 1980)



Figure 3-64. Vicinity map.

Zunamon’s property was affected by the pool of water backed up by a new dam on the Black River 30 miles downstream from Jonesville, Louisiana. Zunamon’s property was on the Tensas (pronounced Tensaw) River and on Bayou Macon. The new pool level kept the water at elevation 34 feet above mean sea level (MSL) and was expected to remain at that elevation.

Parts of the Zunamon property above elevation 37 feet MSL have remained dry but that part between the 34 and 37 foot elevations is claimed to be so saturated that it is not useful for any purpose.

Again, if the damage occurred within the bed of the river as defined by the OHWM, the Government would not be liable.

This trial focused on whether the area below elevation 37 feet MSL was below the OHWM of the Tensas River and the bayou, both of which were already determined to be navigable.

The elevation of Zunamon’s property varied from 25 feet MSL near the confluence of the bayou and the Tensas River to a high of 60 feet MSL in the northern portion. The disputed area was known as “Little Hog Glade,” which had been lower than elevation 37 feet MSL (figure 3-65).

Prior to the dam construction Little Hog Glade was normally covered with flood waters during the 6-month-long

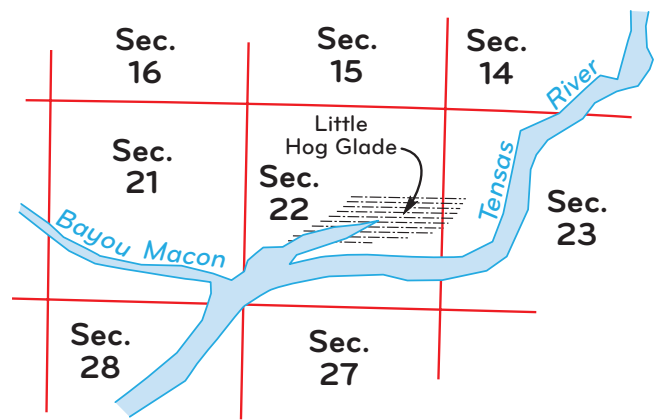


Figure 3-65. Little Hog Glade as shown on USGS maps.

wet season. It was normally free of flood water and the soil was dry during the dry season except for a small area near the confluence of the bayou and the Tensas River (figure 3-66).

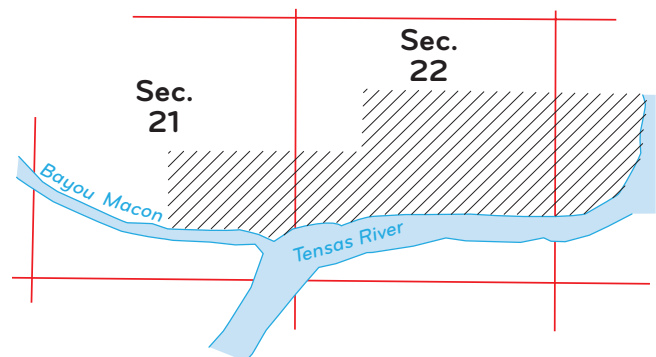


Figure 3-66. The Zunamon property according to patents held from the United States.

A sedge known locally as “nutgrass” and cockleburrs grew throughout Little Hog Glade before the dam construction; hogs and cattle grazed there on the nutgrass. Willows, bitter pecan, overcup oak and water locust trees grew there before the dam construction. These trees normally grow in areas flooded no more than 6 months of the year provided that the ground is relatively dry during the remaining part of the year.

After the dam construction the only shrubbery that grew there was swamp privet, buttonwood, and water elms. These species will grow where the ground is flooded 6 months of the year and where it is also saturated with moisture the remaining 6 months.

Nutgrass no longer grows in Little Hog Glade according to the Court’s findings and it can no longer be used for pasture. The trees are dead or dying.



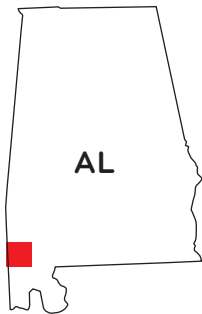
The Government contended at trial that the Tensas and the bayou before the dam was constructed had already “visibly asserted their dominion” over the property up to the 37 foot level. (This is wetlands terminology that has little or nothing to do with OHWM location.)

It was also contended that the soil of Little Hog Glade was not suitable for growing crops, even prior to dam construction.

The Court agreed with the Government’s claim about “asserting their dominion.” The Court would not accept a conclusion that willows, bitter pecan, overcup oak, and water locust trees were aquatic plants simply because they could withstand flooding for 6 months of the year.

Additionally the Judge ruled that the presence of the water at the higher elevation had destroyed the value of the soil for agriculture, noting that forestry is an agricultural occupation. The Government was found liable.

***United States v. Harrell*, 926 F.2d 1036 (11<sup>th</sup> Cir. Ala. 1991)**



**Figure 3-67.** Vicinity map.

The Corps of Engineers sided with a group of commercial fishermen in a dispute over access to Lewis Creek, which is a tributary to the Tombigbee River, a navigable river in Alabama (figure 3-68).

Under Alabama law there was no right of access to nonnavigable rivers, so the fishermen tried to get the creek declared to be a navigable waterway of the United States in order to get access. They wanted to fish there during high water times. The property owners objected.

The trial developed that the Tombigbee River flooded the bottom land every year, generally from December through March. The hardwood forests grew commercially valuable stands of tupelo gum, cypress, wild pecan, willow, hickory, and various types of oak. Those types of trees were found to be terrestrial, rather than aquatic; they will grow on land that is subject to intermittent flooding. Some cypress and tupelo will stand heavy flooding once they become established.

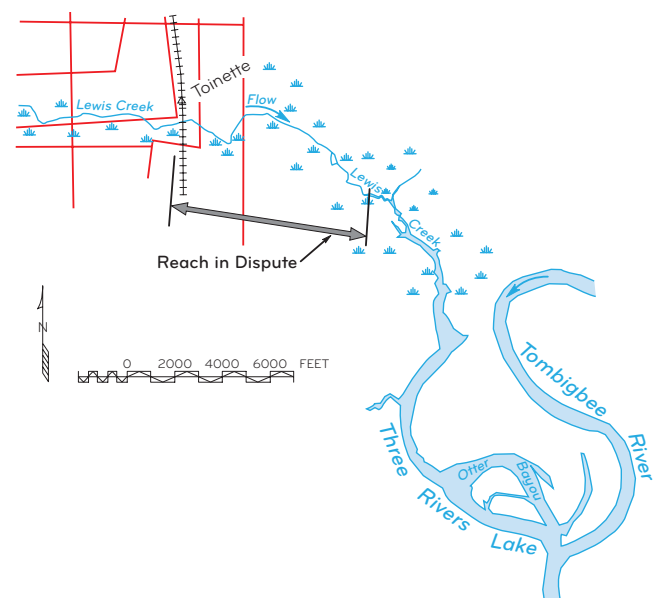
The Trial Court found Lewis Creek to be nonnavigable and the Corps appealed. The trial Judge wrote that Lewis Creek was, “a small, narrow, shallow, obstructed,

partially dry creek that is incapable of any type of waterborne commerce.” The Trial Court stated that the creek “only becomes capable of use for such commerce when the flood waters of the Tombigbee River break out of their banks” into the nonnavigable bed of Lewis Creek (p. 1039).

The Corps claimed that, in the alternative, the bed of the Tombigbee River extended to high, permanent banks that were about 3 miles from the river itself. This 3-mile claim would put the disputed land along Lewis Creek within this extended bed of the Tombigbee River.

The Appellate Court went on to determine whether, if Lewis Creek was not navigable, the Lewis Creek area was within the OHWM of the Tombigbee River. The Court found that the meaning of OHWM does not include land covered by the “‘extraordinary freshets of the winter or spring, or the extreme droughts of the summer or autumn.’ Neither does the bed of the river include the ‘... lateral valleys which have the characteristics of relatively fast land, and usually are covered by upland grasses and vegetation, although temporarily overflowed in exceptional instances when the river is at flood’” (p. 1041). The lower Court had found that the waters of the Tombigbee did not occupy Lewis Creek long enough to destroy the upland vegetation and that flood marks were not sufficient to establish the OHWM.

The Appellate Court ruled that the District Court was correct in finding for the private owners and against the Federal Government and the commercial fishermen.



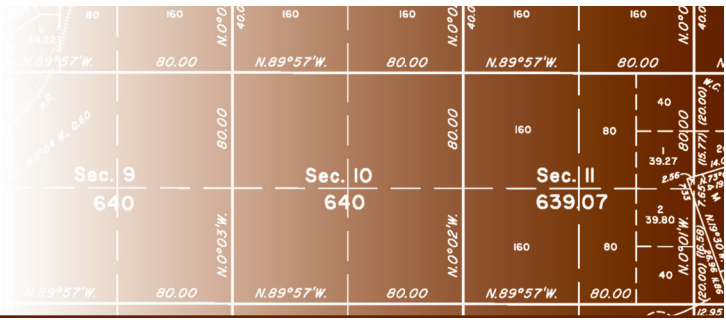
**Figure 3-68.** Lewis Creek vicinity from USGS mapping. Note that the entire area is within 3 miles of the Tombigbee River.





## Chapter IV

# Monumentation



## Introduction

**4-1.** This chapter describes the procedure for monumenting an official survey. Monumentation establishes a permanent marking of the lines and fixes the corner positions so that the location of the surveyed lands may always be definitely known.

## Legal Significance of the Monument

**4-2.** The law provides that the corners marked during the process of an original survey shall forever remain fixed in position, even disregarding technical errors that may have passed undetected before acceptance of the survey.

The courts attach major importance to evidence relating to the original position of the corner, such evidence being given far greater weight than the record relating to bearings and lengths of lines. The corner monument and its accessories constitute direct evidence of the position of the corner.

Title 18 U.S.C. 1858, provides a penalty for the unauthorized alteration or removal of any Government survey monument or marked trees:

Whoever willfully destroys, defaces, changes, or removes to another place any section corner, quarter-section corner, or meander post, on any Government line of survey, or willfully cuts down any witness tree or any tree blazed to mark the line of a Government survey, or willfully defaces, changes or removes any monument or bench mark of any Government survey, shall be fined under this title or imprisoned not more than six months, or both.

The legal importance of the corner makes mandatory the workmanlike construction of lasting monuments

skillfully related to natural objects or improvements so that the greatest practicable permanence is secured.

**4-3.** If it is necessary to alter the condition of a previously established monument, the utmost regard must be shown for the evidence of the original location. The monument will be carefully reconstructed by such additional means as may be appropriate, without destroying the evidence that served to identify that position. A complete record will be kept of the description of the old monument as identified, and all alterations and additions will be specifically noted.

## General Requirements

**4-4.** Prescribed monuments are used to mark the position of the quarter-section, section, township, and meander corners; such sixteenth-section corners as the special instructions or exigencies of the survey of fractional sections require; and all angle points and points at intervals of 40, 80, and 160 chains along an irregular boundary. Additionally, when stipulated in the special instructions, monumentation is established as needed down to the corners of 2½-acre aliquot parts, as may be required in the subdivision of sections into units smaller than the regular quarter-quarter section.

When it is necessary or desirable to establish special purpose monuments, the regulation post is the first choice under usual conditions.

**4-5.** The position of a corner monument is evidenced by the best accessories available. When the corner point itself cannot be marked in any manner, an appropriate witness corner is established. A reference monument is established upon secure ground wherever the corner point falls at a point where it cannot be marked or occupied in the usual manner or where the monument would be liable to destruction.

**4-6.** The field notes relating to the establishment of a monument are introduced at the logical place in the notes where the true position for the corner is indicated.

The description of the monument will embrace (1) the significance of its position; (2) its type and dimensions, including those of any special monumentation; (3) the depth set in the ground, with mention of any additional support; (4) the markings upon the monument; and (5) the nature of the accessories, including character, size, position, and markings.

## Corner Monument Material

**4-7.** The Bureau of Land Management (BLM) has adopted regulation posts for monumenting the official surveys unless exceptional circumstances warrant the use of other material. Substitutions are permitted only when authorized by the officer in administrative charge. In such cases a statement should be given in the field notes explaining why regulation posts were not employed.

**4-8.** Currently there are three types of regulation posts. The posts are made from either Type 304 or 316 stainless steel with a silicon bronze alloy “brass” cap, 6063-T52 aluminum alloy with an aluminum cap, or alloyed iron, zinc-coated with a silicon bronze alloy “brass” cap. The posts are 2½ inches outside diameter, cut to 30 inches in length. The monuments are manufactured with the base of the pipe split for several inches, to facilitate flanging of the monument. The final length of a properly flanged regulation post is 28 inches. The caps on the posts are ¾ inches in diameter, securely attached, fitted with a magnet permanently attached to the underside of the cap, and manufactured with an inscription in the circumference of the top surface of the cap indicating it was authorized by the BLM.

**4-9.** Silicon bronze alloy “brass” tablets are supplied for placing in rock outcrops and imbedding in concrete monuments. The tablet is ¾ inches in diameter, with a stem that is 3½ inches long and ⅝ inch diameter. The top surface bears the same official inscription as the cap of the regulation posts.

**4-10.** General departures from the use of the regulation monument may be authorized where there is need for more durable monumentation or where conditions at the time of survey make it more practicable to adopt an approved substitute. Trials of experimental monuments are authorized from time to time where this can be done without risk of losing corner point locations. Limited departures because of site conditions may be made as approved by the officer in administrative charge.

Native stone may be substituted for the regulation post if it has been authorized by the officer in administrative

charge, is durable against prolonged weathering, has a volume of at least 1,000 cubic inches, and has dimensions suitable for permanent monumentation and appropriate markings. Stone will not be used as a corner monument where its position falls among large quantities of loose surface stone or slide rock. The substitution of stone monuments for regulation posts should be authorized only in exceptional cases.

## Construction of Monuments

**4-11.** The caps of the regulation posts are marked with steel dies when set (sections 4-25 through 4-51). The posts are set in the ground with a magnet encased in plastic deposited under the base. Earth and stone, if the latter is at hand, are tamped into the excavation to give the post a solid anchorage.

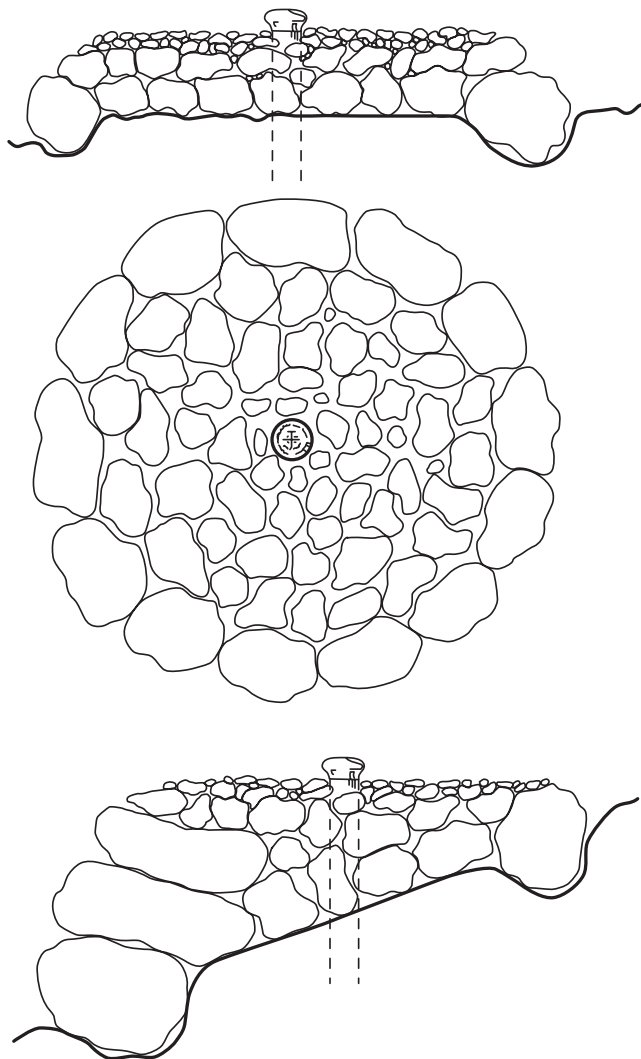
**4-12.** Regulation posts will be set at a depth of three-fourths their length unless it is impossible to complete the excavation. In that case the monument will be planted as deep as conditions will permit, and the necessary support will be secured by a stone mound.

In loose, wind-blown soil, the monument is much more stable if surrounded with stone; the mound being built with a wide base and to the height of the post. This will be even more secure if clay soil can be procured for filling the voids. The location may be of enough importance to justify the construction of a concrete base surrounding the post to prevent the blowing of the soil.

Underpinning or other special means for supporting the post may be required when constructing a stable monument in marshland. Encasement of the post in concrete to prevent corrosion may be necessary in the case of alkaline soils, salts, salt-water marshes, organic-acid water in swamp areas, or similar situations. A stainless steel or aluminum sectional rod monument driven to the point of refusal and topped with a cap may be used where a regulation post cannot be sufficiently supported.

**4-13.** Where the corner point falls upon surface rock, preventing excavation, an “X” is cut at the exact corner point, and if feasible, the monument is erected in the same position, supported by a large mound of stone with broad base, so well constructed that it will possess thorough stability (figure 4-1).

The tablet is used for marking corners that fall upon rock outcrops on slopes where a stable mound would be impracticable. A drill hole is made to receive the stem,



**Figure 4-1.** A mound of stone. The base should be not less than 3 feet in diameter.

and a recess is made for the top so that the tablet may be securely cemented in place and sealed against moisture. To be permanent, the tablet must be secured with clean, first-class materials, carefully proportioned. The tablet is marked in the same manner as the cap of a regulation post. Whenever practical a magnet is deposited beneath the tablet.

On slopes too steep to allow construction of a stable mound but covered with a thin layer of soil that would hide the tablet if it were set directly in the bedrock, a short length of zinc-coated pipe of 1-inch outside diameter, or other suitable material, is forced into the drill hole. The stem of the tablet is then wedged securely into the top of the pipe in a position above the layer of soil.

**4-14.** Where the corner point falls at the position occupied by a tree that is too large to be removed, the tree is marked as the corner monument. A full quota

of accessories referencing the corner point should be secured, including reference monuments.

**4-15.** Monuments marking corners that fall in cultivated fields or meadows are so constructed as to interfere with farming operations as little as possible and conform to the wishes of the owner insofar as practicable without compromising the integrity of the survey.

Generally a regulation post, a brass tablet in a concrete block, a marked stone, or some suitable article may be buried at the corner point, over a magnet encased in plastic, and witnessed by a substantial guard post. Bearing objects or bearing trees within a reasonable distance are used as corner accessories.

## Special-Purpose Monuments

### Witness Corners

**4-16.** A *witness corner* is a monumented point near a corner. It is established only in situations where it is impracticable to occupy the site of a corner with a monument or a mark. A witness corner is a witness to the true corner point. When the true point for a corner falls at an inaccessible place, such as upon a precipitous slope or cliff where the corner cannot be marked, a witness corner is established at some suitable point where the monument may be permanently constructed.

Only one witness corner is established in a secure location, preferably within a 10-chain radius from the true corner point. Establishing a witness corner upon one of the lines leading to a corner is acceptable; however, a suitable location where a permanent monument can be constructed and occupied is of primary consideration. It is desirable to place a witness corner as close to the true corner point as practicable and excessive witness distances should be avoided.

The field notes show the relation between the witness corner and the true point for the corner. The direct connecting course and distance *from* the true point *to* the witness corner are shown on the plat. If there are many witness corners, and in cases of cluttered plat lettering that may interfere with other details on the plat, the data concerning direction and distance may be indicated by marginal memorandum or tabulation (section 6-27).

### Reference Monuments

**4-17.** A *reference monument* is an accessory and is employed in situations where the site of a corner is

such that a permanent monument with a cap cannot be established or where the monument would be liable to destruction.

Where the true point for a corner falls within an unimproved roadway in such a place as to interfere with travel, a regulation post, a tablet in a concrete block, or a stone marked "X" or some suitable article will be buried in the ground, over a magnet encased in plastic, at the true corner point. At least one reference monument is established at a suitable place outside of the roadway if bearing trees or a nearby bearing object are available. At least two reference monuments are established if bearing trees or objects are not available. Allowance should be made for grading, cuts, fills, or other road improvements when placing the reference monuments. Prefabricated monument wells, surrounding the monument, should be considered.

The surface of gravel, macadam, or bituminous-topped roads should not be dug into without the approval of the proper authority. If permission is granted, a deposit, including a magnet encased in plastic, will be made at the true corner point. In the case of a hard surface, a regulation post, a drivable survey monument, tablet, copper bolt, large nail, or the mark "X" may be placed at the true point. Prefabricated monument wells, surrounding the monument, should be considered.

In any event the corner point can be occupied and may be marked temporarily by painting or scratching. Two reference monuments, established following the practice for highway surveys to the extent that is feasible, ordinarily suffice in public survey practice, but four may be employed if desirable. When two monuments are used, they are usually placed equidistant and in opposite directions, preferably on Federal interest land. An acceptable alternative is placement of the monuments so that the lines connecting them with the corner point are approximately perpendicular to each other. Four monuments are placed in opposite directions in the four quadrants. When magnets are deposited under reference monuments, the plastic encasement will be color coded by quadrant.

Reference monuments are described with other accessories to the corner in the field notes but are not shown on the plat.

### Witness Points

**4-18.** A *witness point* is a monumented station on a line of the survey that is used to perpetuate an important

location more or less remote from and without special relation to any regular corner.

The station may be near a road or stream crossing, valuable improvements, the border of a large cultivated field or meadow, an important unmeandered stream or lake, or the border of a reservoir; at the summit of an important slope, ridge, or mountain; or at the intersection with a boundary.

A monumented point along the exterior of a protracted block will be marked as a witness point.

The establishment of a witness point is described in the field notes and may be shown on the plat (section 6-29).

### Angle Points

**4-19.** An *angle point* is a point on a line of a survey of a boundary, usually where the alignment or boundary deflects from a straight line. A point on a line of a legal subdivision that is not a corner of a legal subdivision, such as a line tree, may be marked as an angle point.

The field notes and plat show the relationship of the angle point to a regular corner or to another angle point. The angle point is described in the field notes and shown upon the plat. Numerous angle points, identified sequentially, and connecting courses and distances may be indicated by marginal memorandum or tabulation in cases of cluttered plat lettering that may interfere with other details on the plats.

### Location Monuments

**4-20.** A *location monument* is most frequently used as a reference for one or more special surveys. It is used in any situation where no corner of an existing survey is available to provide a satisfactory connection for an isolated special survey. The monument is generally established in a conspicuous position with good visibility from every direction. A corner of the special survey may be designated as a location monument if it meets this qualification.

The establishment of a location monument is described in the field notes and should be shown on the plat.

### Mineral Monuments

**4-21.** A *mineral monument* is most frequently used as a reference for one or more mineral surveys, and its use is described in detail in sections 10-152 through 10-154.



The monument is generally established in a conspicuous position with good visibility from every direction.

The establishment of a mineral monument is described in the field notes and should be shown on the plat.

### Control Points

**4-22.** A *control point* serves a purpose similar to that of a location monument in connection with a survey. It may be a monumented point that does not meet the qualifications of a previously described special purpose monument. It may be connected directly to a corner or may be related through coordinate values.

The establishment of a control point is described in the field notes and should be shown on the plat, if applicable.

## System of Marking

**4-23.** Monuments are marked using a system that provides ready identification of the monument bearing the marks. Capital letters and Arabic numerals are used to mark the caps of regulation posts, brass tablets, and those trees and stones employed as monuments. The letters and figures relate to the township, range, and section to which the corner belongs.

Previous editions of the Manual may be consulted for the instructions given to the surveyor on the system of marking and placement of stone monuments in surveys.

The marks should be carefully arranged, neat, distinct, and durable. An assortment of steel dies, stone chisels and punches, and timber scribes should be readily available.

**4-24.** An index of the ordinary markings common to all classes of monuments and corner accessories is given in table 4-1.

## Marks on Corner Monuments

### Marks on Regulation Post Monuments and Brass Tablets

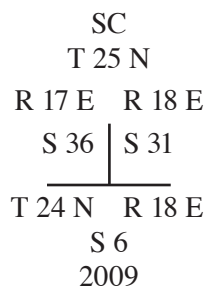
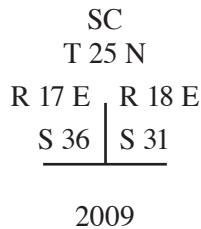
**4-25.** The markings on the cap of the regulation post and tablet corner monument are made to be read from the south side of the monument. The year of the monument's establishment is placed on the south. If the marks are

**Table 4-1.** Index of ordinary markings.

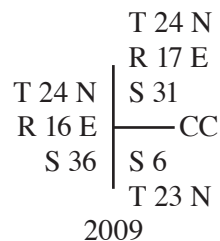
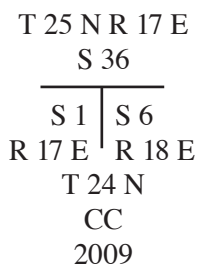
Marks	To indicate—
A	Allotment
AM	Amended monument
AMC	Auxiliary meander corner
AP	Angle point
B	Block
BO	Bearing object
BT	Bearing tree
C	Center
CC	Closing corner
CHS	Chains
CP	Control point
E	East
ECC	Electronic control corner
FT	Feet
L	Lot
LKS	Links
LT	Line tree
M	Mile
MC	Meander corner
MP	Mile post
MS	Mineral survey
N	North
NE	Northeast
NW	Northwest
P	Parcel
PB	Protracted block
PC	Point of curve
PI	Point of intersection
PL	Public lands
PT	Point of tangent
R	Range
RM	Reference monument
S	Section
S	South
SC	Standard corner
SE	Southeast
SMC	Special meander corner
SW	Southwest
T	Township
TR	Tract
USLM	Location monument
USMM	Mineral monument
W	West
WC	Witness corner
WCMC	Witness corner meander corner
WP	Witness point
1/4	Quarter section
1/16	Sixteenth section

changed or added to in the course of a resurvey, the new year number may be marked above or below the original number, but without destroying the former marks.

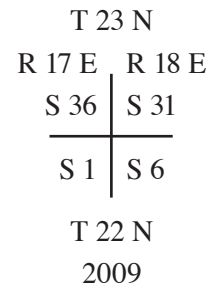
**4-26.** *Standard township corners* are marked “SC” and the township on the north half, and the ranges and sections in the proper quadrants. The township, range, and section on the opposite half may be marked:



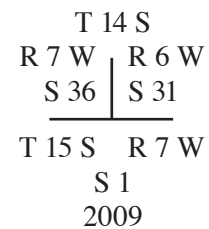
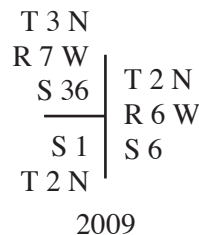
**4-27.** *Closing township corners* are marked “CC” on the half from which the closing line approaches the monument, with the township (or range) on the same half, and the ranges (or townships) and sections in the proper quadrants; also (as far as known at the time) the township, range, and section, or the initials or abbreviation of the reservation, grant, special survey, or private claim upon which the township exterior closes. The name of a State is not placed on the monument even though the monument is intended to be placed on the State boundary unless specifically sanctioned by appropriate authority (section 6-31). (The marks “KIR” indicate an Indian reservation.)



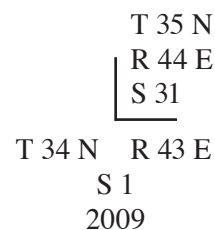
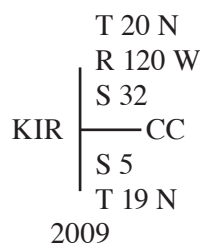
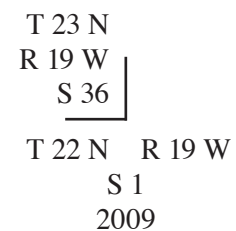
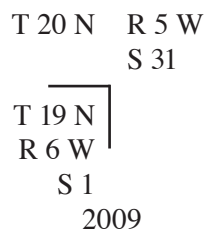
**4-28.** *Corners common to four townships* are marked with the townships on the north and south halves, the ranges on the east and west halves, and the sections in the four quadrants:



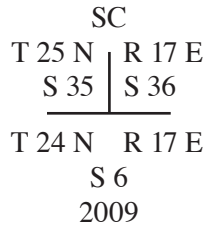
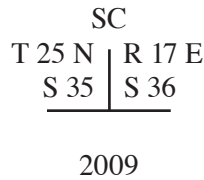
**4-29.** *Corners common to two townships only* are marked with the township (or range) common to both on the proper half, and the ranges (or townships) and sections in the proper quadrants; also (as far as known at the time) the township, range, and section upon the opposite half:



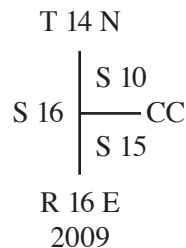
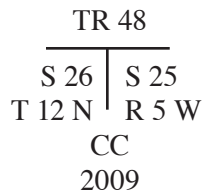
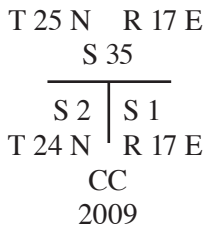
**4-30.** *Corners referring to one township only* are marked with the township, range, and section in the particular quadrant that is concerned; also (as far as known at the time) the township, range, and section upon the opposite part:



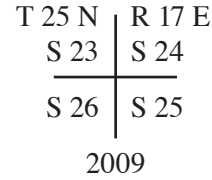
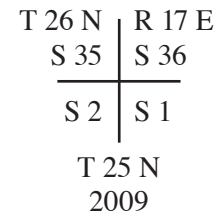
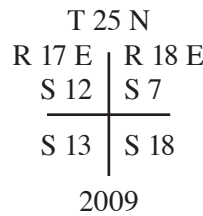
**4-31.** *Standard section corners* are marked “SC” and the township and range on the north half, and the sections in the proper quadrants. The township, range, and section on the opposite half may be marked:



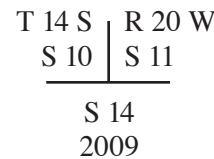
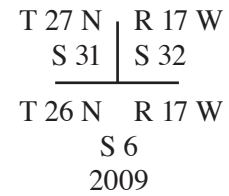
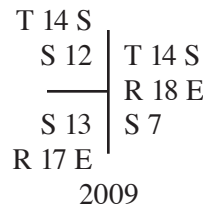
**4-32.** *Closing section corners* are marked “CC” and the township and range on the half from which the closing line approaches the monument, and the sections in the proper quadrants; also (as far as know at the time) the township, range, and section, or the initials or abbreviation of the special survey including reservation, grant, or private claim, upon which the section line closes, with the exception that in the case of an interior closing section corner, the township and range numbers are not repeated:



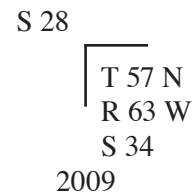
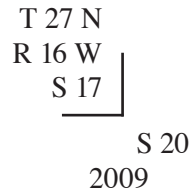
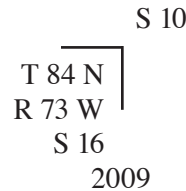
**4-33.** *Corners common to four sections* are marked (1) on an exterior, with the township (or range) common to the adjoining townships, the ranges (or townships) upon the opposite sides of exterior, and the sections; and (2) on a subdivisional corner, with the township, range, and sections:



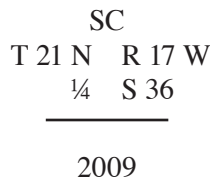
**4-34.** *Section corners common to two sections only* are marked with the township and range on the half facing the sections to which the corner belongs, and the sections in the proper quadrants; also (as far as known at the time) the township, range, and section upon the opposite half, except that in the case of an interior corner, the township and range numbers are not repeated:



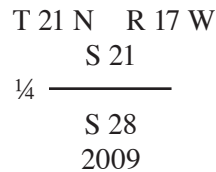
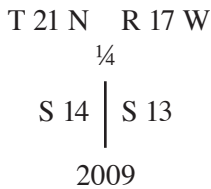
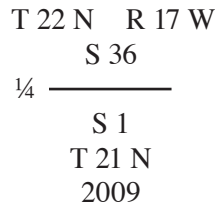
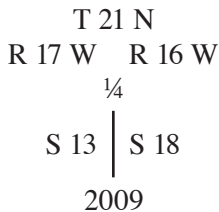
**4-35.** *Section corners referring to one section only* are marked with the township, range, and section in the particular quadrant that is concerned; also (as far as known at the time) the section upon the opposite part:



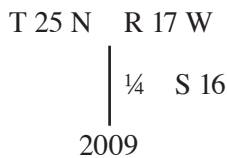
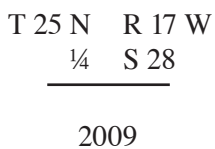
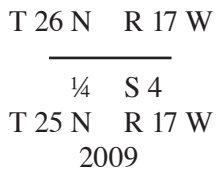
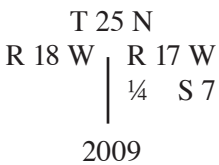
**4-36.** *Standard quarter-section corners* are marked with “SC”, the township, range, “¼,” and the section, all on the north half:



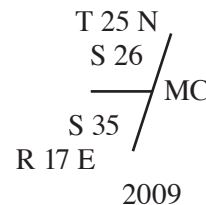
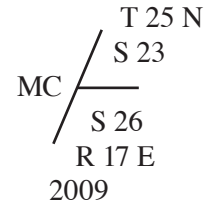
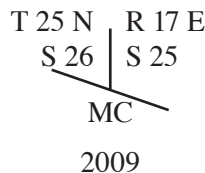
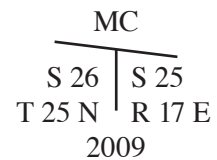
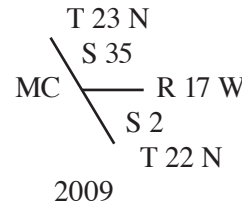
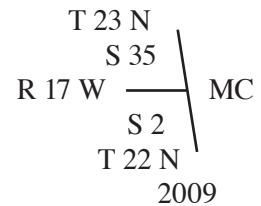
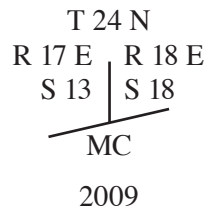
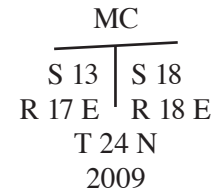
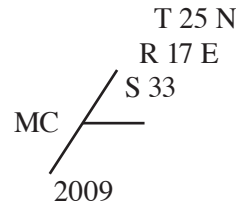
**4-37.** *Quarter-section corners of maximum control* are marked (1) on a meridional exterior, with the township and “¼” on the north, and the ranges and sections on the east and west halves; (2) on a latitudinal exterior, “¼” on the west, the range on the north, and the townships and sections on the north and south halves; (3) on a meridional subdivisional line, with the township and range on the north, “¼” on the north, and the sections on the east and west halves; and (4) on a latitudinal subdivisional line, with the township and range on the north, “¼” on the west, and the sections on the north and south halves:



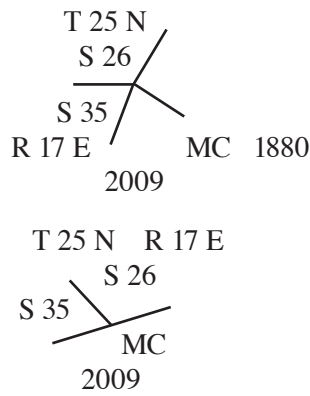
**4-38.** *Quarter-section corners of minimum control* are marked (1) on a meridional exterior with the township on the north, ranges on the east and west and “¼” and the section on the half toward the particular section that is concerned; (2) on a latitudinal exterior, with the township and range on the north and south halves, and “¼” and the section on the half toward the particular section that is concerned; and (3) on a subdivisional line, with the township and range on the north, and “¼” and the section on the half toward the particular section that is concerned:



**4-39.** *Meander corners* are marked “MC” on the half toward the meanderable body of water, and the additional marks (1) on a standard parallel or other line controlling surveys to one side only, with the township, range, and section toward the surveyed land; (2) on an exterior, with the township (or range) common to the adjoining townships, the ranges (or townships) upon the opposite sides of the exterior, and the sections; and (3) on a subdivisional line, with the township, range and sections:



**4-40.** The extension of lines for division of accretions or beds of waterbodies has the same character as the lines being extended. Different methods can be used to meet management purposes. The endpoints will be marked to distinguish them from each other. The date of the prior survey is used in the example shown. For extension of subdivision-of-section lines see section 4-45.

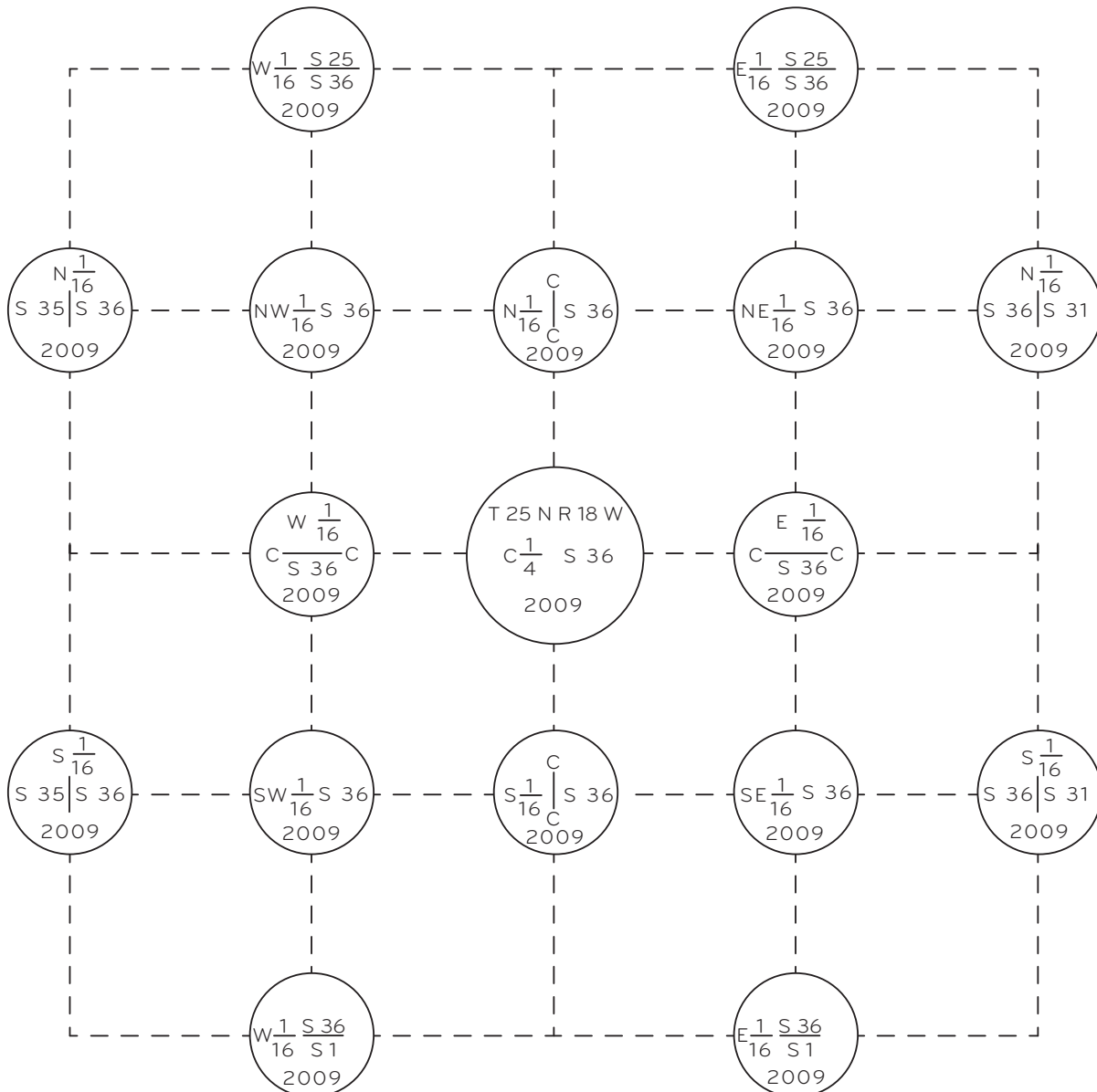


**4-41.** Interior quarter-section corner and all sixteenth-section corners, when required by the special instructions are marked in accordance with the scheme shown in figure 4-2.

**4-42.** Corners of minor subdivisions, where a quarter-quarter section is subdivided into quarter-quarter-quarter sections (1/64 or 10-acre units), or aliquot parts as small as 1/256 (2.5 acres), the monuments on the boundaries of the quarter-quarter section, and those needed for the perimeter lines within the quarter-quarter section, are marked on the plan indicated in figure 4-3.

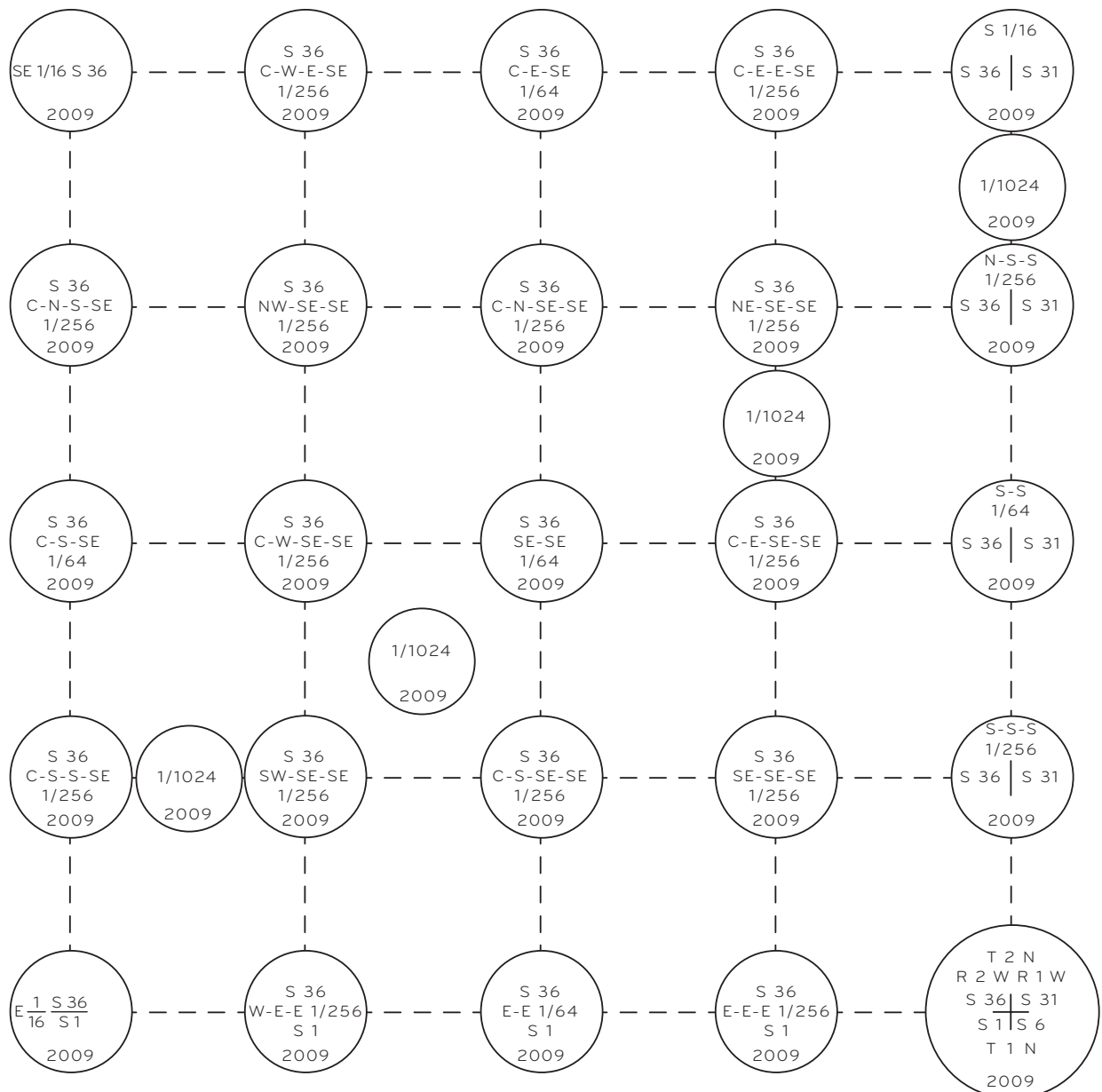
Figure 4-3 shows the marking for the monuments at corners of 2.5-acre units within one regular quarter-quarter section. If those units or any one of them are quartered, only the fraction 1/1024 and the year are used for marking monuments of that order.

Markings on monuments at the corners of 1/64 and 1/256 of a section, when subdivided as aliquot parts, for



**Figure 4-2.** Marks on monuments at interior quarter-section corners and all sixteenth-section corners.

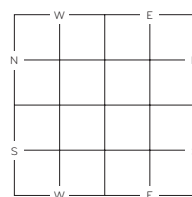




**Figure 4-3.** Marks on monuments at corners of minor subdivisions. If 1/1024 section corners are established, only “1/1024” and the year are marked on the brass cap or tablet.

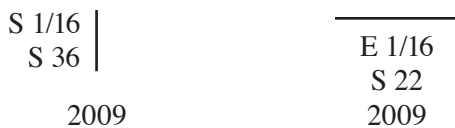
example on the boundaries of and within the SE $\frac{1}{4}$ SE $\frac{1}{4}$  sec. 36 are shown in figure 4-3.

**4-43.** Sixteenth-section corners of minimum control are marked with a key letter (N, E, S, or W) to indicate the position of the monument, and “1/16” and the section, all on the half toward the particular section that is concerned (figure 4-4):



**Figure 4-4.** Key for marks on sixteenth-section corners of minimum control.

**4-44.** Corners of elongated sections require additional monuments on section boundaries where the length of the closing line exceeds 85 chains. These are placed at intervals of 40 chains counting from the regular quarter-section corner. The plan for the special marking is based upon the distance each monument is established from the regular governing boundary, generally the south or east. In cases where special circumstances call for the establishment of corners within the section, the monuments are also marked with reference to the



subdivision-of-section lines upon which they are placed. The markings are illustrated by figures 4-5 and 4-6. Special attention should be given to whether the markings of monuments on the section boundaries are to show maximum or minimum control.

**4-45.** *Special meander corners* are marked in accordance with the following scheme (figure 4-7):

Key letters (N, E, S, W, or C) are used in pairs to indicate the position of the subdivision-of-section line.

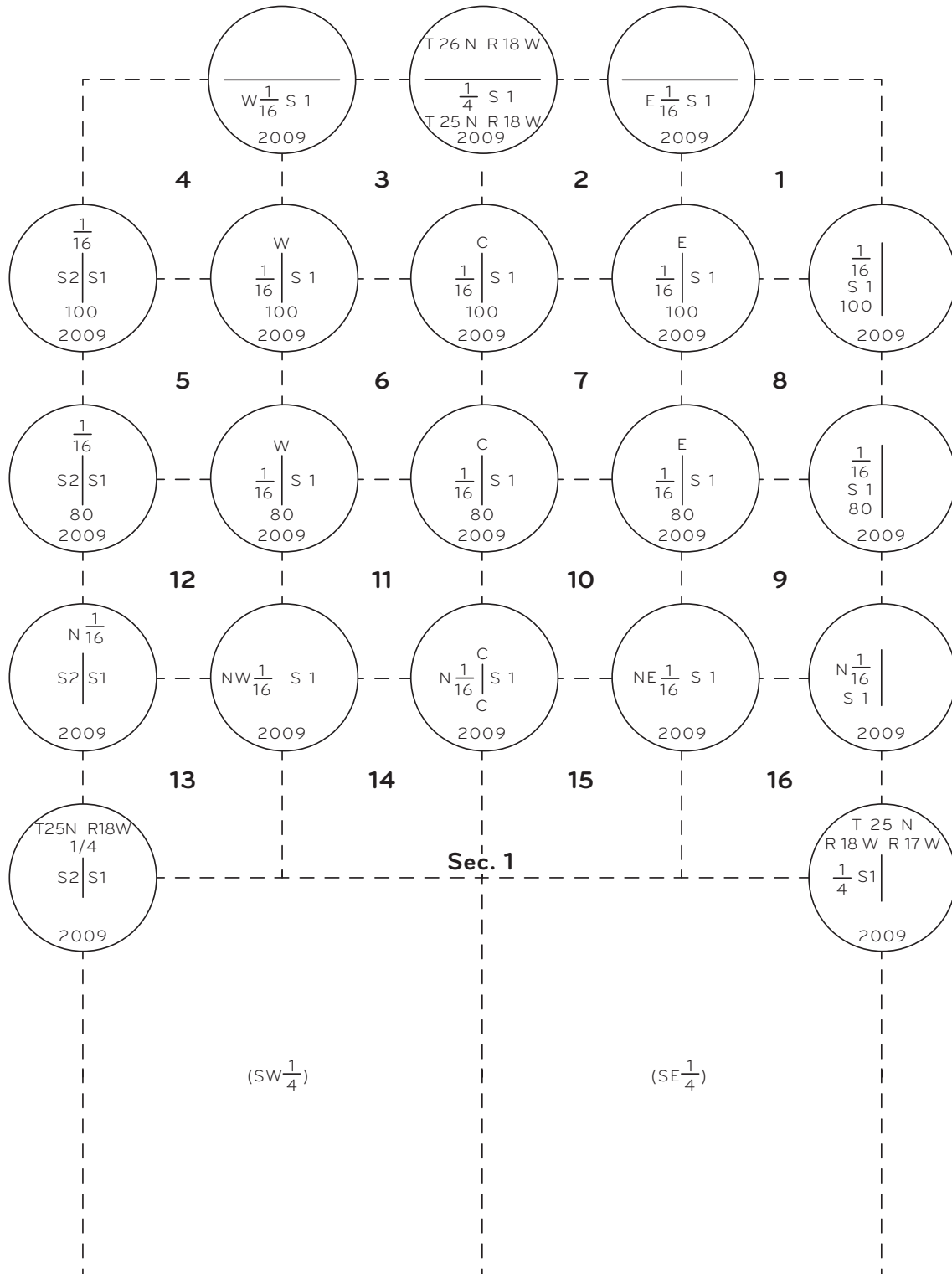


Figure 4-5. Marks on monuments at the corners of an elongated section to the north.

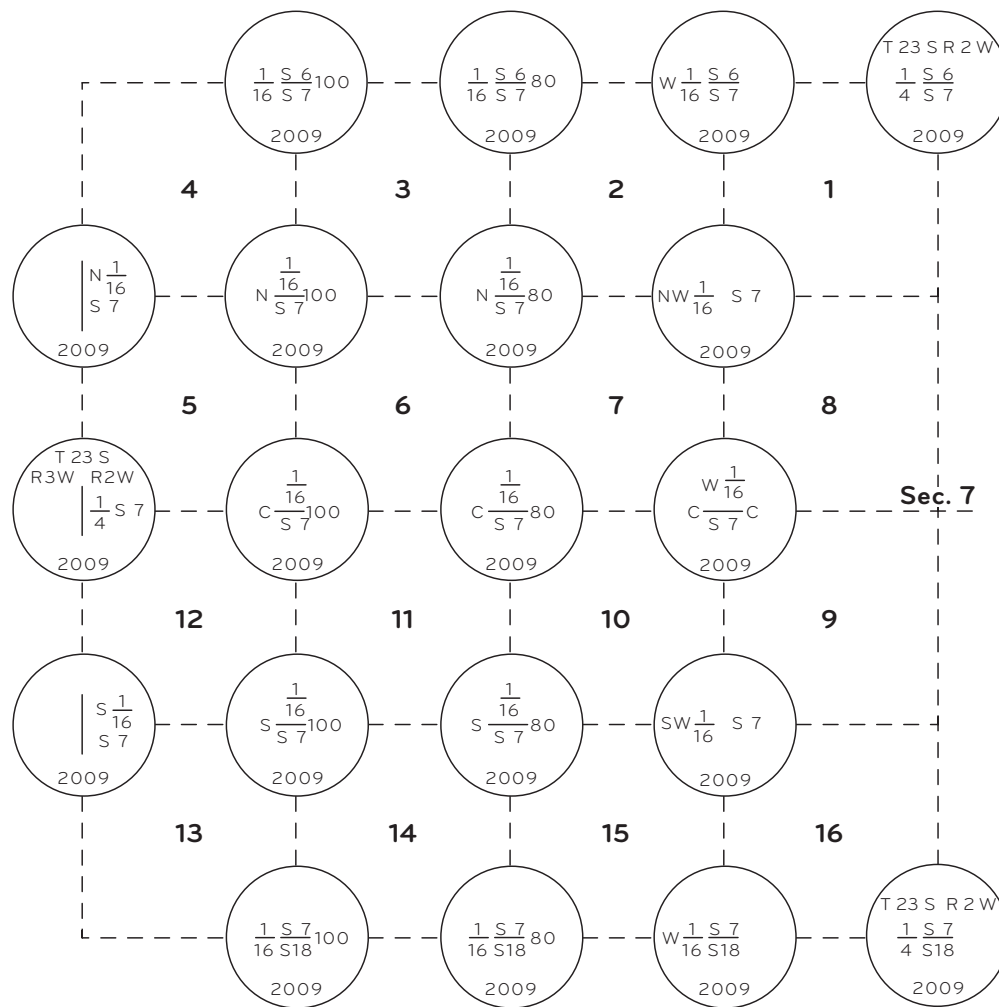


Figure 4-6. Marks on monuments at the corners of an elongated section to the west.

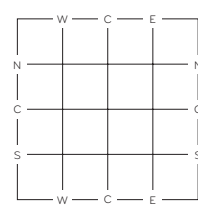
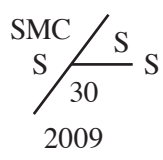
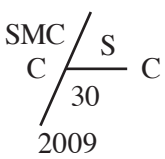
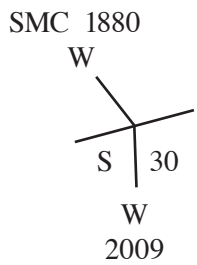
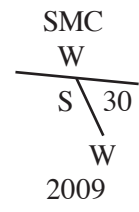
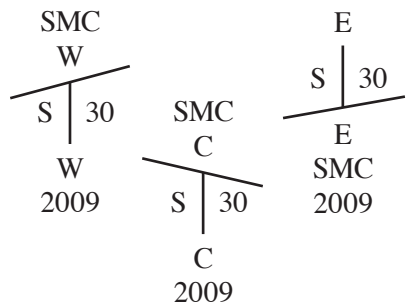


Figure 4-7. Key for marks on special meander corners.

The marks “SMC” are place on the half toward the meanderable body of water, and the section on the opposite half:



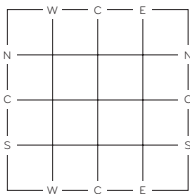
Marks on corners at endpoints of extension of lines for division of accretions or beds of waterbodies, see section 4-40.

**4-46.** Auxiliary meander corners are marked “AMC” and the township, range, and section:

AMC  
T 64 N R 37 W  
S 29  
2009

When two or more auxiliary meander corners are required for islands in the same section, they should be identified by lot or tract number, not by serial number.

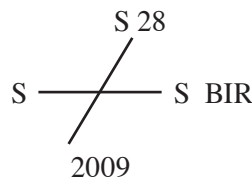
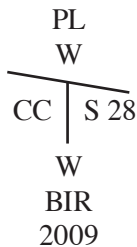
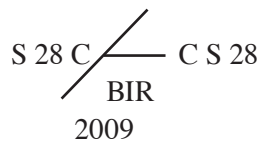
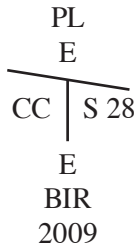
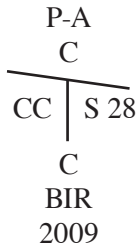
**4-47.** Closing subdivision-of-section corners are marked in accordance with the following scheme (figure 4-8):



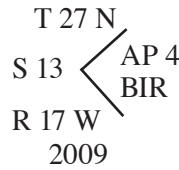
Key letters (N, E, S, W, or C) are used in pairs to indicate the position of the subdivision-of-section line.

The marks “CC” and the section are placed on the half from which the closing line approaches the monument (the marks “BIR” indicate “Blackfeet Indian Reservation”; the marks “P-A” indicate “Parcel A”).

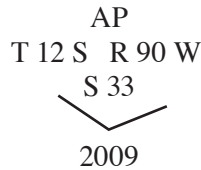
**Figure 4-8.** Key for marks on closing subdivision-of-section corners.



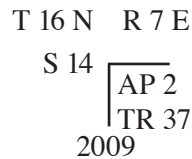
**4-48.** Miscellaneous angle points on irregular boundaries are marked:



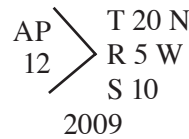
For “angle point No. 4” on the boundary of the “Blackfeet Indian Reservation,” falling on surveyed land.



For “angle point” on the south boundary of section 33, superseding an old standard corner on a defective line, not subject to rectification.

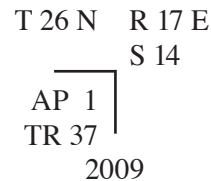
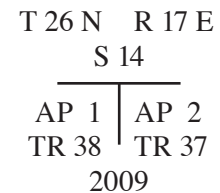
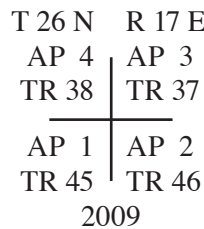


For “angle point No. 2” on the boundary of a private claim (“Tract No. 37”) falling on surveyed land.

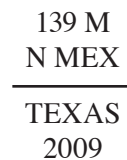


For “angle point No. 12” on a reestablished nonriparian meander line; the marks “AP” and the serial number are placed on the half toward the land erroneously omitted from the original survey.

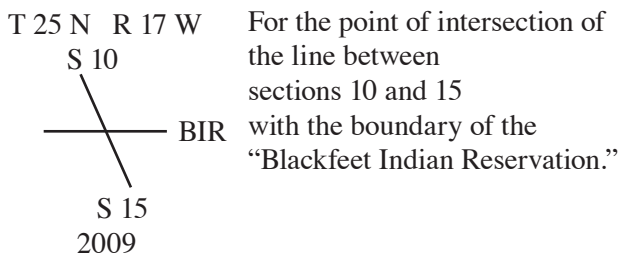
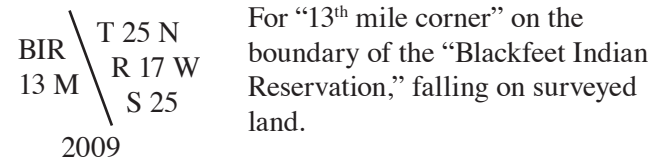
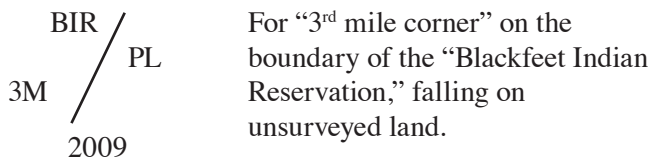
**4-49.** Angle points on tract boundaries:



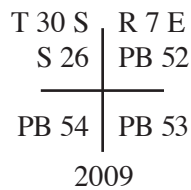
**4-50.** Intermediate corners along boundaries or at point of intersection with boundaries are marked:



For “139<sup>th</sup> mile corner” on the boundary line between the States of “New Mexico and Texas.”



**4-51.** Section corners common to protracted blocks are marked with the township, range, and the protracted blocks and sections in the proper quadrants:



### Marks on Tree Monuments

**4-52.** Where the corner point falls at the position occupied by a tree that is too large to be removed, the tree is made the monument.

Where a tree is to be made a monument, the species of the tree and its diameter at breast height are noted. The appropriate marks are made upon the trunk of the tree immediately above the root crown. A series of marks to be made upon a particular side of a tree are scribed in a vertical line reading downward. If a tree is too small to receive the usual marks without injury, this tree is marked with an “X” only at breast height on the *south* side. The “X” should be scribed in the bark on smooth-barked trees. On rough-barked trees the “X” may be made by two axe cuts reaching fully through the cambium and just into the xylem. It is advantageous to clear out nearby trees of similar size in order

that the marked tree will not be smothered by faster growing uninjured trees.

If the corner point differs significantly from the center of the tree, the field notes will so state. Consideration will be given to using reference monuments to indicate the corner point exactly.

**4-53.** Because of the durability of certain trees, including the aspen, beech, and locust (smooth and thin-barked), the marks may be made by scribing well into the bark through the cambium and just into the xylem without blazing; the marks made this way will remain as long as the tree is sound. On the rough-barked trees, the marks will be scribed into a smooth, narrow, vertical blaze, specially prepared by removing just enough of the bark, cambium, and xylem to expose a flat surface. The marks made this way will remain as long as the tree is sound, but the blaze and marks will be covered by a gradual overgrowth, showing an outward scar for many years. In regions subject to heavy snowfall it is desirable to make an additional, small blaze at a height of 6 to 8 feet above the ground, which will serve to attract attention to the tree during the winter season. The ends of the blaze should be smoothed off gradually without making a sharp cut into the live wood tissue. The lower end of the blaze upon which the marks are placed should be sloped downward to prevent water pooling, be about 6 inches above the root crown, and be just sufficient in length to take the marks.

Trees should be marked in a way that will cause the least possible injury and enable rapid overgrowth. Placing the marks at the bottom ensures that they will remain on the stump if the tree is cut down.

**4-54.** The above caution applies equally to the marking of bearing trees, and the surveyor should not remove the overgrowth on a tree monument or bearing tree unless it is absolutely necessary in order to identify the tree. The marks on old bearing trees should not be disturbed or added to. New trees may be marked, which will be recorded in the field notes.

In the case of trees that have been blazed before marking, the number of rings contained in the overgrowth (or its equivalent on the adjoining sections of the tree) furnish count of the number of years (one ring for each growing season with usually one growing season per year for most locations) from the date of original marking to the date when uncovered. Uncovering an old blaze leaves it subject to decay, and the surveyor will adopt additional means to evidence the position of the corner.



**4-55.** *Standard township corners* are marked “SC” and the township on the north side, and the ranges and sections on the east and west sides:

SC T25N on N.,  
R18E S31 on E., and  
R17E S36 on W. side.

**4-56.** *Closing township corners* are marked “CC” and the township (or range) on the side from which the closing line approaches the monument, and the ranges (or townships) and sections on the adjoining sides; also the initials or abbreviation of the reservation, grant, special survey, or private claim, on the side toward any irregular tract that may be closed upon:

R18E S6 on E.,  
CC T24N on S., and  
R17E S1 on W. side.

**4-57.** *Corners common to four townships* are marked with the township and section on the northeast and southwest sides, and the range and section on the southeast and northwest sides:

T23N S31 on NE.,  
R18E S6 on SE.,  
T22N S1 on SW., and  
R17E S36 on NW. side.

**4-58.** *Corners common to two townships only* are marked with the township, range, and section on the sides toward the particular townships:

T2N R7W S1 on SW., and  
T3N R7W S36 on NW. side.

**4-59.** *Corners referring to one township only* are marked with the township, range, and section on the side toward the particular township concerned:

T23N R7W S36 on NW. side.

**4-60.** *Standard section corners* are marked “SC” and the township and range on the north side, and the sections on the east and west sides:

SC T25N R17E on N.,  
S36 on E., and  
S35 on W. side.

**4-61.** *Closing section corners* are marked “CC” and the township and range on the side from which the closing line approaches the monument, and the sections on the adjoining sides; also the initials or abbreviation of the reservation, grant, special survey, or private claim on the side toward any irregular tract that may be closed upon:

S1 on E.,  
CC T24N R17E on S., and  
S2 on W. side.

**4-62.** *Corners common to four sections* are marked (1) on an exterior, with the township (or townships), ranges (or range) and sections; and (2) a subdivisional corner, with the township, range and section:

(1) T25N S7 on NE.,  
R18E S18 on SE.,  
R17E S13 on SW., and  
S12 on NW. side.

(1) T26N S36 on NE.,  
R17E S1 on SE.,  
T25N S2 on SW., and  
S35 on NW. side.

(2) T25N S24 on NE.,  
R17E S25 on SE.,  
S26 on SW., and  
S23 on NW. side.

**4-63.** *Section corners common to two sections only* are marked with the township and section, and the range and section, on the sides toward the particular sections to which the corner belongs:

T14S S11 on NE., and  
R20W S10 on NW. side.

**4-64.** *Section corners referring to one section only* are marked with the township, range and section on the side toward the particular section concerned:

T27N R16W S17 on NW. side.

**4-65.** *Standard quarter-section corners* are marked “SC $\frac{1}{4}$ ” and the section, all on the north side:

SC $\frac{1}{4}$  S36 on N. side.

**4-66.** *Quarter-section corners of maximum control* are marked (1) on a meridional line, “¼” and the section on the west side, and the section on the east side; and (2) on a latitudinal line, “¼” and the section on the north side, and the section on the south side:

- (1) S18 on E., and  
¼ S13 on W. side.
- (2) ¼ S21 on N., and  
S28 on S. side.

**4-67.** *Quarter-section corners of minimum control* are marked “¼” and the section, all on the side toward the particular section that is concerned:

- ¼ S7 on E. side  
(for quarter-section corner on  
the west boundary of section 7).

**4-68.** *Meander corners* are marked “MC” on the side toward the meanderable body of water, and the additional marks (1) on a standard parallel or other line controlling surveys to one side only, with the township, range and section on the side toward the surveyed land; (2) on an exterior, with the township (or range) common to the adjoining townships on the side opposite the meanderable body of water, and the ranges (or townships) and the sections on the adjoining sides; and (3) on a subdivisional line, with the township and range on the side opposite the meanderable body of water, and the sections on the adjoining sides:

- (1) MC on E., and  
T25N R17E S33 on NW. side  
(for meander corner on a standard  
parallel, on the west side of a  
meanderable body of water).
- (2) T24N on N.,  
R18E S18 on E.,  
MC on S., and  
R17E S13 on W. side  
(for meander corner on a range line,  
on the north side of a meanderable  
body of water).
- (2) T23N S35 on N.,  
MC on E.,  
T22N S2 on S., and  
R17W on W. side  
(for meander corner on a township line, on  
the west side of a meanderable body of water).

- (3) S23 on N.,  
T25N R17E on E.,  
S26 on S., and  
MC on W. side  
(for meander corner on a latitudinal section line,  
on the east side of a meanderable body of water).

- (3) MC on N.,  
S9 on E.,  
T4N R7W on S., and  
S8 on W. side  
(for meander corner on a meridional section line,  
on the south side of a meanderable body of water).

**4-69.** *Special and auxiliary meander corners* are marked “SMC” or “AMC,” as the case may be, on the side toward the meanderable body of water, and the section on the opposite side:

- SMC on E., and  
S14 on W. side  
(for special meander corner  
on a latitudinal subdivision-of-section line  
in section 14, on the west side of a  
meanderable body of water).

- AMC on N., and  
S9 on S. side  
(for auxiliary meander corner in section 9,  
on south side of a meanderable body of water).

## Marks on Special-Purpose Monuments

**4-70.** At a witness corner, the marks on the cap of a regulation post monument or tablet are arranged as on a regular corner monument but with the addition of the letters “WC” on the north and an arrow pointing to the true point for the corner. On a tree, two hacks are made on the north and south sides on a meridional line or two hacks on the east and west sides on a latitudinal line.

**4-71.** A reference monument normally is marked the same as a bearing tree located in a similar position, with the addition of an arrow pointing to the corner point, and the year, and substituting the letters “RM” for “BT.” Where reference monuments are established at corners of minimum control, including corners on standard lines, the monument established in the section to which the corner does not refer is marked only with the letters

“RM,” an arrow pointing to the corner point, and the year. If there is sufficient space on the cap or tablet, the distance to the true corner may be stamped beside the arrow.

**4-72.** At a witness point the brass cap or tablet is marked “WP” at the top, the year at the bottom, and “S” with the section number or “PB” with the protracted block number on each of the halves appropriate for the line of survey. Monuments at witness points situated on subdivision-of-section lines or at other unusual places are marked as provided for in the special instructions. A tree intersected by the true line is marked as a line tree and has the same function as a witness point.

**4-73.** The markings on an angle point are as described previously in section 4-48.

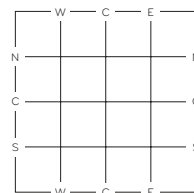
**4-74.** A location monument should consist of a regulation post or tablet similar to the type used for rectangular surveys, set three-fourths of its length in the ground, over a magnet encased in plastic, and with a conical mound of stone 4 feet high and having a 6-foot base alongside. The letters “USLM” followed by the special survey number or reference are marked on the brass cap or tablet. The exact reference point is indicated on the top of the monument by a cross (+). Any necessary departure from the prescribed material and size of monument is to be explained in the returns. The site, when practicable, is to be some prominent point, visible from every direction, where the permanency of the monument would not be endangered by snow, rock, or land movements or other natural causes. A detailed description of the location monument, including its geographic position, is to be furnished in the record of the survey.

**4-75.** The markings on a mineral monument are described in section 10-153.

**4-76.** Control point monuments are marked with the year at the bottom, a cross (+) at the center, and other markings as required to assure positive identification.

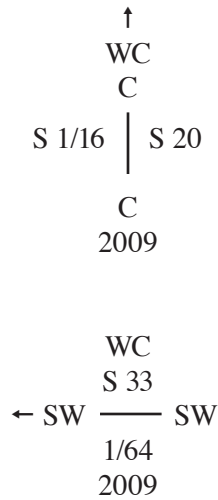
**4-77.** If a line tree is marked in the survey, two hacks, at breast height, are made on the north and south sides on a meridional line or two hacks on the east and west sides on a latitudinal line.

**4-78.** *Special purpose corners* are marked in accordance with the following scheme (figure 4-9):



**Figure 4-9.** Key for marks on special purpose corners.

Key letters (N, E, S, W, or C) are used in pairs to indicate the position of the subdivision-of-section line.



## Corner Accessories

**4-79.** The purpose of an accessory is to evidence the position of the corner monument. A connection is made from the corner monument to fixed natural or artificial objects in its immediate vicinity, whereby the corner may be relocated from the accessory. Thus, if the monument is destroyed or removed, its position may be identified by any remaining evidence of the accessories. One or more kinds of accessories are employed at each corner established in the official surveys (except for corners of minor subdivisions and where specifically not required by the Manual, or omitted by the special instructions).

Accessories consist of (1) bearing trees; (2) bearing objects such as notable cliffs or boulders, permanent improvements, buried objects, or reference monuments; (3) mounds of stone; (4) memorials; or (5) pits. Aside from availability, selection is based on their order of permanence.

**4-80.** The surveyor cannot perform any more important service than that of establishing permanent and accurate evidence of the location of the corners of a survey. Where the accessories cannot be employed, other means should be adopted that will best serve the purpose.

### Bearing Trees

**4-81.** Bearing trees are selected for marking when available, ordinarily within a distance of 3 chains of

the corner; a greater distance if important. One tree is marked in each section unless a tree in one or more positions may not be available. A full description of each bearing tree is given in the field notes. This includes the species of each tree, its diameter at breast height, the exact direction from the monument to the center of the tree, the horizontal distance counting to the center of the tree at its root crown; and, the exact marks scribed for the identification of the corner (figure 4-10). Any variation of recording this information will be detailed in the field notes.

**4-82.** The marks upon a bearing tree are made upon the side facing the monument, scribed in the manner already outlined for marking tree corner monuments. The marks embrace the information suggested in sections 4-93 through 4-112, with such letters and figures as may be appropriate for a particular corner, and will include the letters “BT.” A tree will be marked to agree with the section in which it stands, and will be marked in a vertical line reading downward, ending in the letters “BT” at the lower end of the blaze approximately 6 inches above the root crown.

**4-83.** There is a great difference in the longevity of trees, and in their rate of decay; therefore, select trees according to the length of their probable life, their soundness, favorable site conditions and size. Sound trees, not matured, of the hardiest species, favorably located, are preferred for marking. Trees 5 inches or less in diameter should not be selected for marking if larger trees are available, and it is generally better to avoid marking fully matured trees, especially those showing signs of decay. Trees 4 inches in diameter, or less, if no better trees are available, are marked with the letter “BT” only at the base, and an “X” at breast height, facing the monument. The species, size and exact position of the bearing trees are of vital importance, as this data will generally serve to identify a bearing tree without uncovering the marks, or even to identify two or more stumps after all evidence of the marks has disappeared.

**4-84.** Generally only one tree is marked in each section at a particular corner, but in certain instances two trees are required in a section. In such cases it is better to select trees of different species or of widely different size, direction or distance. If the trees are of the same species, one is marked with an “X” only and “BT” at the base. This procedure should avoid any confusion regarding the location of the corner if one of the trees had disappeared.

## Bearing Objects

**4-85.** Almost any nearby object that can be readily identified may be recorded by description, course, and distance. Such objects may not be of a character that can be marked, excepting in the case of a rock cliff or boulder. The description of the cliff or boulder should provide ready identification, including the marking of an “X” plainly and deeply chiseled at the exact point to which the direction and distance are recorded.

**4-86.** The letters “XBO” are chiseled into a bearing object, if it is a rock cliff or boulder; the record should enable another surveyor to determine just where the marks will be found. The rock bearing object is the most permanent of all accessories; it is used wherever practicable, and within a distance of 5 chains of the corner.

**4-87.** A connection to any permanent artificial object or improvement may be included in this general class of corner accessories. The field notes will be explicit in describing such objects, and will indicate the exact point to which a connection is made, as “southwest corner of foundation of Smith’s house,” “center of Smith’s well,” “pipe of Smith’s windmill,” etc. No marks should be made upon non-Federal property without the consent of the owner.

**4-88.** Where the full quota of trees or other bearing objects are unavailable for marking, the position of the monument is, under favorable conditions, evidenced by buried objects, preferably magnetic. No object should be buried where the earth will readily erode or otherwise be disturbed. All buried objects will be deep enough to remain undisturbed by surface displacement, and far enough from the corner monument to remain undisturbed if the corner monument itself is destroyed. A description of the buried object is embodied in the field notes, and will include a statement of description and location. The plastic encasement of buried magnets will be color-coded by quadrant to avoid later confusion in the identification of a remaining magnet where evidence of a companion magnet has disappeared.

## Memorials

**4-89.** In order to increase the permanency of the corner point location, a suitable memorial is deposited directly beneath each corner monument. A memorial may consist of any durable article that will serve to identify the location in case the monument is destroyed. Such articles will be magnetic. A magnet should be encased in plastic. When a magnet is not available such articles as





Mark D. Dixon, BLM Cadastral Surveyor, retired

**Figure 4-10.** A monumented corner, marking and measuring a bearing tree.

pieces of metal, glassware, stoneware, a stone marked “X,” a charred stake, or a quart of charcoal constitute a suitable memorial. A full description of such articles is embodied in the field notes wherever they are employed as a memorial. When replacing an old monument with a new one, such as substituting a regulation post for an old marked stone, the old marker is preserved as a memorial buried alongside, below the ground surface if possible, and a suitable memorial is deposited directly beneath the new monument.

### Mounds of Stone

**4-90.** Where native stone is available and the surface of the ground is favorable, a mound of stone is employed as an accessory to a corner monument, or to surround it, even though a full quota of trees, other bearing objects or memorials can be utilized. A mound of stone erected as a corner accessory should be built as stable as possible, should consist of not fewer than five stones, and should be not less than 3 feet in diameter at the base and



1½ feet high. Where the ground is suitable, the stone mound is improved by first digging a circular trench, 4 to 6 inches deep, for an outer ring, then placing the base of the larger stones in the trench. In stony ground, increase the size of the mound to make it conspicuous. The position of the accessory mound is shown in sections 4-93 through 4-112. The nearest point on its base should be about 6 inches distant from the monument. The field notes show the size and position of the mound to the center of the mound.

**4-91.** Where it is necessary to support a monument in a stone mound and if bearing trees or other above ground objects are not available, a magnet encased in plastic or other bearing object is deposited in the ground at a nearby safe location as an accessory. A description of the accessory and its location is embodied in the field notes.

A stone mound accessory, in addition to the mound surrounding a monument, is built wherever this will aid materially in making the location conspicuous.

### Pits

**4-92.** Where the full quota of trees or other bearing objects are unavailable for marking, the position of the monument is, under favorable conditions, evidenced by pits.

Pits are poor accessories and are rarely used in modern official surveys. For instructions on how to dig and place pits, consult the 1973 edition of the Manual. Previous editions of the Manual may be consulted for the instructions given to the surveyor on the digging and placement of pits in older surveys.

## Arrangement and Marking of Corner Accessories

**4-93.** A magnetic memorial encased in plastic is deposited directly beneath each corner monument, if practicable. The memorial is described in the field notes with the corner monument.

**4-94.** *Standard township corners and standard closing corners* have two bearing trees, one in each section north of the standard parallel, each marked “SC” and the township, range, and section as

T25N R18E S31 SC BT.  
Mound of stone, north of corner.

**4-95.** *Closing township corners and closing section corners* have two bearing trees, one in each section to the right and left of the closing line, each marked “CC” and the township, range, and section as

T24N R18E S6 CC BT.  
Mound of stone, on the closing line.

**4-96.** *Corners common to four townships* have four bearing trees, one in each section, each marked with the township, range, and section as

T22N R17E S1 BT.  
Mound of stone, south of corner.

**4-97.** *Corners common to two townships only* have two bearing trees, one in each section cornering at the monument, each marked with the township, range, and section as

T2N R7W S1 BT.  
Mound of stone, on the line between the two townships cornering at the monument.

**4-98.** *Corners referring to one township only* have two bearing trees, both in the township cornering at the monument, each marked with the township, range, and section, but if same species, one is marked with an “X” only as

T23N R19W S36 BT or  
X BT.  
Mound of stone, in the township cornering at the monument, at 45° from cardinal direction at the monument.

**4-99.** *Corners common to four sections* have four bearing trees, one in each section, each marked with the township, range, and section as

T26N R17E S35 BT.  
Mound of stone, west of corner.

**4-100.** *Section corners common to two sections only* have two bearing trees, one in each section cornering at the monument, each marked with the township, range, and section as

T14S R17E S12 BT.  
Mound of stone, on the line between the two sections cornering at the monument.



the case may be, and the section, but if same section and of same species, one is marked with an “X” only as

S14 SMC BT,  
S14 AMC BT or  
X BT.

Mound of stone, on the opposite side of the monument from the meanderable body of water.

**4-109.** *Closing subdivision-of-section corners* have two bearing trees, both in the particular section that is concerned, each marked “CC” and the section, but if same section and of same species, one is marked with an “X” only as

S9 CC BT,  
PB S9 BT,  
S28 BIR BT or  
X BT.

Mound of stone, on the closing line.

**4-110.** *Miscellaneous angle points along irregular boundaries* have: (1) Two bearing trees, where the monuments are less than 1 mile apart, one on each side of the boundary; and (2) four bearing trees, where the monuments are 1 mile or more apart, two on each side of the boundary; each marked “AP” and a serial or section number, or both, also the initials or abbreviation of the State, reservation, grant, special survey, private claim, or public land, as appropriate, but if same marks and of same species one is marked with an “X” only as

AP2 TR37 BT, and  
AP S14 BT (for “angle point No. 2” on the boundary of a private claim “Tract No. 37” falling on surveyed land) or  
X BT.

Mound of stone, on the medial line between the boundary lines intersecting at the monument, and in the direction toward the reservation, grant, special survey, or private claim.

The placing of a stone mound on a State boundary is *on the line*, north from the monument if the field notes of the survey or retracement are written to read running north; to the east, if running to the east, etc. In the boundary surveys, where stone is available, it is good practice to build a substantial stone and earth mound surrounding and to the top of the monument; this will usually be conspicuous without an additional stone mound.

**4-111.** *Intermediate corners along or at point of intersection with boundaries* have: (1) Two bearing trees,

where the monuments are less than 1 mile apart, one on each side of the boundary; and (2) four bearing trees, where the monuments are 1 mile or more apart, two on each side of the boundary; each marked with the number of the mile or half-mile corner and the letter “M” to (indicate “mile corner”), and the initials or abbreviation of the State, reservation, grant, special survey, private claim or public land, as appropriate, but if same marks and of same species, one is marked with an “X” only as

47 M COLO BT, and  
47 M OKLA BT (for “47th mile” corner on the boundary line between the States of “Colorado” and “Oklahoma”)  
S15 BIR BT or  
X BT.

Mound of stone, on a line at right angles to the boundary, and in direction toward the reservation, grant, special survey, or private claim.

**4-112.** *Section corners common to protracted blocks* have four bearing trees, one in each protracted block or section, each marked with the township, range and protracted block or section as

T42N R7W PB45 BT.  
Mound of stone, west of corner.

**4-113.** The accessories to special-purpose monuments are selected and marked as follows:

(1) **Witness Corner:** Bearing objects, if available, are treated as for a regular corner. Bearing trees, with direction and distance from the monument, are marked with an “X” at breast height, on the side facing the monument and the letters “BT” at the base. Mounds of stone are treated as though the monument were located at the true corner.

(2) **Reference Monument:** All bearing objects and bearing trees, including marks, refer to the position of the regular corner, as this position will be occupied with a monument or mark.

(3) **Witness Point:** No requirements are set up as to the accessories for a witness point, other than to mark a bearing tree or a bearing object, if available, or to establish a suitable bearing object. A bearing tree is marked in the same manner as a bearing tree associated with an angle point.

(4) Line Tree: When an accessory is necessary to evidence the position of a line tree, no requirements are set up other than to mark a bearing tree or a bearing object, if available, or to establish a suitable bearing object. A bearing tree is marked in the same manner as a bearing tree associated with an angle point.

(5) Angle Point: Described in sections 4-19 and 4-110.

(6) Location Monument: From the monument the precise course and distance is to be taken to two or more bearing trees or rock bearing objects. Bearing trees are scribed "USLM" and the rock bearing objects chiseled "XBO" together with the number of the location monument.

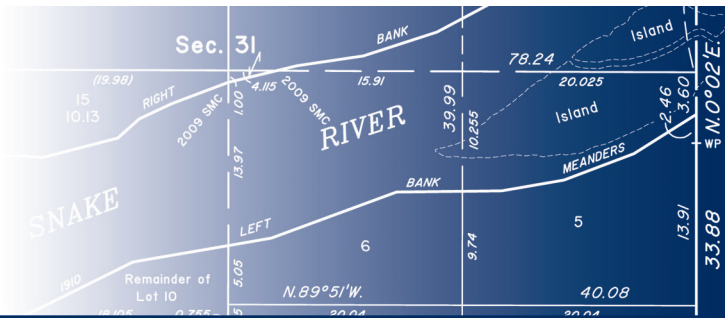
(7) Mineral Monument: Described in section 10-154.





## Chapter V

# Principles of Resurveys



## Resurveys

**5-1.** A dependent *resurvey* is a reconstruction of land boundaries and subdivisions accomplished by rerunning and re-marking the lines represented in the field-note record or on the plat of a previous official survey. The resurvey includes a field-note record describing the technical manner in which the resurvey was made, full reference to recovered evidence of the previous survey, surveys, or resurveys, a complete description of the work performed and monuments established, and a plat that represents such resurvey. The resurvey, like an original survey, is subject to approval of the directing authority and official filing.

**5-2.** Government resurveys involve considerations of a different character from those relating to original surveys. The object of a resurvey is twofold: First, the adequate protection of existing rights acquired under the original survey in the matter of location on the earth's surface, and second, the proper marking of the boundaries of the remaining Federal interest lands.

**5-3.** Although the discussion in this chapter pertains especially to the resurvey of an entire township, the same principles apply in the smaller projects necessary for proper management of the Federal interest lands. The resurvey of smaller parcels must be considered in context with the township as it was typically the unit of the original survey. The same principles apply to the resurvey of an official resurvey, and to a local survey as the resurvey of an official original survey.

**5-4.** A local survey is any survey, retracement, or remonumentation of township, section, subdivision-of-section, or special survey lines that is not an official survey. In the performance of a dependent resurvey, prior official resurveys and local surveys subsequent to the original survey should be considered in the context of the objectives of each resurvey. These objectives may include (1) adequate protection of the bona fide rights as to location in good faith reliance on evidence of the

original survey and (2) acceptable location by the subsequent official or local resurvey to allow the proper marking of the boundaries of the Federal interest land.

**5-5.** The function of county or other local surveyors begins when the surveyors undertake the identification of lands that have passed from the Government into private ownership, based upon the description derived from the original survey. Their work should consist largely of running and marking the subdivision-of-section lines and corners. An official survey retracing and monumenting a local survey of purported legal subdivisions of a section is technically not a dependent resurvey. However, by law, weight shall be given to locally marked boundaries insofar as they are based on good faith reliance on evidence of the original survey and protect bona rights (sections 5-24 through 5-35) as to location of the boundaries of alienated land.

**5-6.** Upon the issuance of a patent for land by the Federal Government, it is just as if the monuments, survey plat, field notes, laws, regulations, and rules governing how to survey the land described in the patent, are attached to the face of the patent (*Cragin v. Powell*, 128 U.S. 691 (1888)). The survey rules are spelled out in the manuals, circulars, instructions, and regulations issued by the General Land Office (GLO) and its successor, the Bureau of Land Management (BLM).

If later a boundary location becomes unclear, the applicable Manual of Surveying Instructions governs the relocation of the corners and boundaries in conformance with the controlling monuments, survey plat(s), field notes, policies, regulations and laws. The general exception is the boundary created when the United States owned neither side of the boundary. In such cases, the appropriate State or foreign laws and rules must be consulted first for weighing the controlling elements. For boundaries in Public Land Survey System (PLSS) States where State law applies, many States have incorporated the Manual or portions thereof into their definitions, rules of constructions, and their elements of control of boundary locations.

**5-7.** A cadastral surveyor working in the context of prior official resurveys or local surveys must recognize that such surveys may provide the best available evidence of the original survey. Often the surveyor is faced with the case of two monuments, each purporting to mark the same corner, each linked to the original survey, and each identified by substantial evidence of the original corner position. Generally, within the PLSS, the second position in time will have the burden to prove, by a preponderance of the evidence, that the first position is not an accurate retracement and reestablishment of the lines of the original survey.

**5-8.** In boundary litigation, the land status usually determines the court of competent jurisdiction. Different jurisdictions assign different weights to (1) the level of notice to all affected landowners of conflicting positions, (2) the level of use or occupancy, or improvements based upon each position, and (3) the elements of control of boundary locations.

**5-9.** In conducting a resurvey, care must be exercised to avoid disturbing satisfactory local conditions such as roads, fences, or other improvements marking subdivision-of-section lines and that may correctly define the extent of established bona fide property rights.

**5-10.** A *dependent resurvey* is a retracement and reestablishment of the lines of the original survey or of a prior resurvey in their true original positions according to the best available evidence of the positions of the original corners. The monuments, section lines, and lines of legal subdivision of the dependent resurvey represent the best possible identification of the true legal boundaries of lands alienated on the basis of the plat of the original survey. In legal contemplation and in fact, the lands contained in a certain section of the original survey and the lands contained in the corresponding section of the dependent resurvey are identical.

**5-11.** The determination of the best available evidence of the original survey involves consideration of both direct and collateral evidence. Direct evidence from the record of the original survey should lead to the adoption of certain points as existent corners, while both direct and collateral evidence may lead to the adoption of other points as obliterated corners. The examination and careful consideration of the bona fide rights of non-Federal interests may lead to further collateral evidence of the original survey, or may lead to a modification of the basic control of the dependent resurvey. These concepts are more fully developed in chapter VI.

**5-12.** An *independent resurvey* is a retracement and reestablishment in reliance on evidence of the original survey in order to give official recognition and respect to all alienated lands within its scope, and where applicable, it also includes an establishment of new section lines, and often new township lines, independent of and without reference to the corners of the original survey. In an independent resurvey, it is necessary to preserve the boundaries of those lands previously alienated by legal subdivisions of the sections of the original survey that are not identical with the corresponding legal subdivisions of the new sections of the independent resurvey. This is done by surveying them as tracts, or by conforming the alienated lands to the subdivisions of the resurvey if that can be done suitably.

**5-13.** As in the case of original surveys, the records of resurveys must form an enduring basis upon which depends the security of title to all lands later acquired thereunder. The surveyor must therefore exercise the greatest care in conducting the field work and in preparing the record so that the resurvey will relieve existing difficulties as far as possible without introducing new complications. Each decision made by the surveyor must be recorded in and supported by the official record. Accordingly, the record must contain adequate information or analysis to support each such determination or conclusion.

**5-14.** A *retracement* is a survey that is made to ascertain the direction and length of lines and to identify the monuments and other marks of an established prior survey. Retracements may be made for any of several reasons. In the simplest case it is often necessary to retrace several miles of line leading from a lost corner that is to be reestablished relative to an existent corner that will be used as a control. If no intervening corners are reestablished, details of the retracement are not usually shown in the record, but a direct connection between the two corners is reported as a tie. On the other hand, the retracement may be extensive, made to afford new evidence of the character and condition of the previous survey. Recovered corners are rehabilitated, but a retracement does not include the restoration of lost corners. The retracement may sometimes be complete in itself, but usually is made as an early part of a resurvey.

**5-15.** The United States may resurvey or reestablish boundaries of Federal interest lands for its own information. This is done as necessary, but the resurvey cannot affect the rights of any claimant, entryman, or owner situated along and outside of the boundaries of the Federal interest lands. The authority to make

resurveys is subject to the necessary limitation that the courts shall protect private rights based upon the original survey and plat, and in some instances, based upon official resurveys and local surveys, against interference by the newer resurvey.

In a fundamental restatement of the law, *Cragin v. Powell*, 128 U.S. 691, 698 (1888), articulates the finding principle governing the PLSS. The Supreme Court of the United States cited with favor the following quotation from a letter of the Commissioner of the GLO to the surveyor general of Louisiana:

The making of resurveys or corrective surveys of townships once proclaimed for sale is always at the hazard of interfering with private rights, and thereby introducing new complications. A resurvey, properly considered, is but a retracing, with a view to determine and establish lines and boundaries of an original survey, . . . but the principle of retracing has been frequently departed from, where a resurvey (so called) has been made and new lines and boundaries have often been introduced, mischievously conflicting with the old, and thereby affecting the areas of tracts which the United States had previously sold and otherwise disposed of.

**5-16.** The principles of dependent resurveys of alienated lands are applicable for lands selected under the Alaska Statehood Act (72 Stat. 339, as amended), with some exceptions, as of the date of tentative approval prior to the issuance of final patent.

For lands selected under the Alaska Native Claims Settlement Act (43 U.S.C. 1621(j), as amended), the principles of dependent resurveys of alienated lands are also applicable, with some exceptions, as of the date of interim conveyance prior to issuance of patent. Upon the official filing of the survey conducted subsequent to the interim conveyance and prior to issuance of patent, the Secretary shall make appropriate adjustments to ensure that the recipient receives the full entitlement. The confirmation of the boundary descriptions by survey shall not change the interim conveyance but shall clarify what was intended in the interim conveyance.

## Jurisdiction

**5-17.** Dependent resurveys have been made since the early days of the public land surveys. Initially they were made as corrective surveys under the general

surveying appropriations when gross errors were found. Dependent resurveys of particular public land surveys in certain States were later authorized by special acts of Congress. General legislation providing for dependent resurveys was enacted when it became apparent that many older surveys were so obliterated or distorted that the lines could not be identified with certainty. Hence the original plat was disqualified as the basis for the management or disposal of the remaining Federal interest lands.

Congress authorized the Secretary of the Interior to (1) make dependent resurveys upon application by settlers, claimants, entrymen, landowners, grantees, courts, or managers of Federal lands; (2) to reestablish the boundaries of those lands the title to which has passed from the United States; and (3) to execute the retracement and re-marking of lines of older surveys in order to identify the boundaries between Federal interest and private lands to satisfy conservation needs and land use demands. (See information on authorities and jurisdiction in chapter I.)

**5-18.** When such survey is appropriate, a general resurvey of Federal interest or Indian lands is issued through the BLM Director as delegated by the Secretary of the Interior. Other Federal agencies vested with the administration of the lands may request resurveys by addressing the Director through the usual official channels. Indian tribes, Indian individuals, Alaska natives, claimants, entrymen, or other landowners and courts may take the preliminary steps of requesting a resurvey. The request should note the known conditions with respect to the monuments and other marks, discrepancies if known or alleged, and the limits of the initiators' ownership and be submitted to the supervising BLM officer.

Prior to title passing from the United States, it is undisputed that the Government has the power to survey and resurvey, establish and reestablish boundaries on its own lands (*United States v. Reimann*, 504 F.2d 135 (1974), citing *Lane v. Darlington*, 249 U.S. 331 (1919)). Historically, the Secretary of the Treasury, then the Secretary of the Interior, acting first through the GLO, and then through the BLM, has had the authority to exercise this jurisdiction. In fact, while various Federal agencies have carried out surveys or resurveys in the exercise of their land management authority, it is only to the BLM that specific authority to survey and resurvey the public lands, as well as Federal interest lands, generally, has been given. As discussed elsewhere in this Manual, the BLM has also been charged with the responsibility of maintaining the integrity of the PLSS.

The Government also has the power to resurvey boundaries between the Federal Government and owners of lands that have passed from Federal ownership, as long as it does not impair bona fide rights of owners of land that have passed from Federal ownership. The BLM is authorized to perform such official dependent resurveys (43 U.S.C. 772 and 773). However, as between owners of lands, the title to which has passed from United States (i.e., both sides of the boundary have passed), final determination in the matter of fixing the position of disputed land boundaries rests with the local courts of competent jurisdiction. The rules of procedure established by the BLM and the Manual of Surveying Instructions guiding its surveyors in re-marking lines of previous surveys are intended to be in harmony with the leading court decisions in suits and administrative decisions in appeals involving boundary disputes. The rules should be applied that the courts may, with security, accept the boundaries determined as representing the true location of a particular piece of land intended to be alienated. Official resurveys are undertaken only when duly authorized, and when the field work is assigned to a cadastral surveyor, who in that manner is then acting under the authority of the Secretary of the Interior through the Director of the Bureau of Land Management and under the immediate direction of a BLM Chief Cadastral Surveyor.

**5-19.** There are certain questions of a purely judicial nature involved in resurveys of every description where the administrative decision is reserved to the Director of the Bureau of Land Management. This is particularly true of decisions relating to compliance with the general laws in respect to valid entry of the public lands. In such cases the surveyor's duty is to identify and mark out on the ground the various legal subdivisions of the Federal interest lands, including Indian lands. It is a judicial question, beyond the function of the surveyor, to determine whether or not specified lands have been duly earned under a given law authorizing conditional entry.

In the dependent resurvey process, the surveyor determines whether lands embraced within a claim as occupied have been correctly related in position to the original survey. The surveyor must examine and weigh the evidence relating strictly to the surveying problem involved. The surveyor will interpret the evidence and its effect upon the resurvey to protect valid rights acquired under the original survey. The surveyor has no authority to enter into an agreement concerning the exchange of one subdivision for another or to bind the BLM in such particulars.

**5-20.** Challenges to the United States' title to real property are authorized by the Quiet Title Act of 1972

(86 Stat. 1176; 100 Stat. 3351; 28 U.S.C. 2409a, as amended). The Quiet Title Act is the basis to adjudicate a disputed title to real property in which the United States claims an interest. It is within the realm of the survey, approval, and filing process to provide a record upon which the court of competent jurisdiction in a Quiet Title suit may clearly and accurately determine the boundaries of the United States claim of interest and may, with security, accept the boundaries thus determined insofar as they represent the true location of the Federal interest. Legal questions of courtroom procedure, title, or the interest in title that may affect location of land parcels on the earth's surface will be determined in consultation with a legal advisor.

**5-21.** One additional caution, addressed especially to surveyors employed by the Bureau of Land Management, is to bear in mind that their professional work is technical in character, but often must address issues of law and equity. Surveyors are not referees as to the justice or injustice of a situation. Surveyors can only act upon the equities or inequities that may appear to be involved if they fall within the Secretary of the Interior's duties and discretionary authorities.

The surveyor does not have the authority to decide boundary disputes, but may be regarded as one qualified by special knowledge and experience to testify in such cases. The cadastral surveyor acting for the Secretary of the Interior will permanently mark the extent of the Federal interest land. The authority to resolve boundary disputes and make final determination on the boundary of Federal interest lands is vested in the Federal courts. The court in its legal capacity hears evidence and makes findings of fact from the official survey records and the testimony of witnesses, including the surveyor.

**5-22.** Under the Administrative Procedure Act, the scope of review prescribed for courts is that agency action shall be set aside if found to be "arbitrary, capricious, an abuse of discretion, or otherwise not in accordance with law" (5 U.S.C. 706(2)(A)) or if such action is unsupported by substantial evidence (5 U.S.C. 706(2)(E)). It is a well established principle of administrative law that Federal courts show deference to the interpretation of statutes made by agencies charged with the administration of those statutes, and respecting matters subject to agency regulations about which the agency has special knowledge or expertise.

The court is qualified to exercise discretion as to the weight of the evidence, its acceptability, and by court



decree to enforce its opinion. The court determines the facts as to the sufficiency of the control, or extent of the monuments and other marks of the official survey that can be relied upon, and how that control is to be applied. This will be binding in fixing the boundaries of privately-owned property, as well as in fixing the boundaries between the Federal interest lands and the alienated lands. However, even the court itself possesses no authority to set aside the original official survey, all actions affecting the surveys of the United States having been delegated by Congress to the Secretary of the Interior.

**5-23.** The above conditions and procedures are recognized in the leading court opinions and administrative law decisions involving boundary cases. Such opinions and decisions are available in law libraries, and in governmental and commercial databases. Reference books and boundary law treatises on the legal elements of surveying and boundaries also cite court opinions and administrative decisions of the Department of the Interior dealing with these subjects. Treatment by competent authorities on questions relating to the acceptability of testimony and physical survey evidence, demonstrates the importance of the surveyors' due qualifications, accuracy, character, and integrity (sections 6-20 through 6-22).

## Bona Fide Rights of Claimants

Note: The procedures for protecting bona fide rights as to location are outlined in chapter VI.

**5-24.** In order to carry out the provisions of law relating to resurveys, the surveyor must understand the meaning of the term "bona fide rights" and under what circumstances it will be held that such rights have been impaired by a resurvey. The Act of March 3, 1909 (35 Stat. 845), as amended June 25, 1910 (36 Stat. 884), and October 21, 1976 (90 Stat. 2792; 43 U.S.C. 772), reads in part: "That no such resurvey or retracement shall be so executed as to impair the bona fide rights or claims of any claimant, entryman, or owner of lands affected by such resurvey or retracement."

The rights of claimants are to be similarly protected under the provisions of the Act of September 21, 1918 (40 Stat. 965; 43 U.S.C. 773).

**5-25.** Bona fide rights are those acquired in good faith under the law. A resurvey can affect bona fide rights

only in the matter of *location* on the earth's surface. The surveyor will be concerned only with the question of whether the lands covered by such rights have been actually *located* in good faith. Other questions of good faith (such as priority of occupation, possession, continuous residence, value of improvements and cultivation, or mistaken belief as to the location of alienated lands) do not affect the problem of resurvey except as they help to define the position of the original survey or provide evidence of a Federal interest boundary inconsistent with patent or deed descriptions.

**5-26.** The dependent resurvey shall afford adequate protection to bona fide rights as to location vested in both improved and unimproved lands. The surveyor must recognize the necessity for some flexibility regarding the survey methods used and understand that if an arbitrary process of dependent resurvey were rigidly applied, the value of both of these classes of lands could be vitally affected. This is particularly true when determining the true position of all lands, whether improved or unimproved, in the absence of sufficient evidence of original corners.

The question for the surveyor in such cases is whether the claimant made a good faith effort to locate the claimed land on the ground, based on the best available evidence of the survey under which the claim was allowed. Arbitrary location (with no reliance on at least one Federal monument) cannot qualify as having established a bona fide right as to location.

**5-27.** Special case dependent resurveys are sometimes necessary to protect the bona fide rights of someone who has located on the lands (section 6-58). Unimproved lands may be located to a position found by the surveyor to be conformable to adjoining or nearby tracts, where all may be held to qualify under the rules of acceptable good faith location (sections 6-35 through 6-49).

**5-28.** The basic principles of protecting bona fide rights are the same in either the dependent or independent resurvey. Each is intended to show the original positions of alienated lands included in the original description. The dependent resurvey shows alienated lands as legal subdivisions, the independent resurvey as legal subdivisions or segregated tracts. Each is an official demonstration by the Bureau of Land Management according to the best available evidence of the former survey. There is no legal authority for substituting the methods of an independent resurvey disregarding identified evidence of the original survey.



## General Field Methods

**5-29.** The position of a tract of land, described by legal subdivisions, is absolutely fixed by the original corners and other evidences of the original survey and not by occupation or improvements unrelated to the original survey or by the lines of a resurvey that do not follow the original as faithfully as possible for the time. A conveyance of land must describe the parcel to be conveyed so that it may be specifically and exactly identified, and for that purpose, the law directs that a survey be made. Under fundamental law, the corners of the original survey are unchangeable. Even if the original survey was poorly executed, it still controls the boundaries of land alienated under it.

**5-30.** In most areas that require resurveys the survey of record can be reconstructed by the methods of the dependent resurvey. The principal resurvey problem is one of obliteration of monuments and corner accessories with a comparative absence of large discrepancies. This most often occurs where the controlling official survey had been made faithfully, enabling it to be reconstructed as it was originally. The special instructions in such cases typically call for a retracement and dependent resurvey, which may be carried out at the same time if no complications develop. Even where the record survey proves to be badly distorted, the extent of private ownership may dictate that the resurvey will be of the dependent type. Many areas have a checkerboard pattern of ownership as the result of railroad or military road grants, and similar conditions are found where extensive disposals have been made. Since an independent resurvey cannot affect boundaries of lands already alienated, it serves little purpose where every section line is the boundary of private land.

**5-31.** Occasionally, after a dependent resurvey has commenced, complications develop that make the methods described in the special instructions inapplicable. Provision should always be made in the special instructions calling for the surveyor to report such facts to the supervising office. The report should embody the same information as that required in the report of a field examination hereinafter outlined in section 5-33.

**5-32.** Provided that a large enough area of Federal interest land remains to warrant it, the methods of the independent resurvey are employed if there are intolerable discrepancies in the original survey. This occurs where the controlling survey was not faithfully executed with the result that some lines were not established and

therefore have no actual existence and cannot be reconstructed to conform to the fictitious record. The boundaries of alienated lands in such areas are given special treatment for their protection, as nearly in harmony as possible with what could be afforded by a court of competent jurisdiction. Action will be taken to suspend the plat of record as a basis of further disposals, leases and other land or resource transactions before an independent resurvey is commenced.

When it is probable that an independent resurvey will be necessary, the special instructions should provide that a preliminary field examination be made. No new monuments are constructed during the examination. Interested parties are to be informed that the examination is being made strictly for the purpose of developing information of the prior survey. They should also be informed that if a resurvey is to be undertaken later, it will be planned primarily for the protection of all valid existing rights, and possibly with a view to the running of new lines for the identification of the remaining Federal interest lands. The details of such a plan of resurvey cannot be given in advance of formal action upon the report of examination.

**5-33.** The field examination report consists of a diagram to scale, a narrative, and the field notes of the retracements made, as follows:

- (1) The diagram shows the correlation of existent original corners, corners established by local surveyors, and any monuments of unknown origin. Line fences, line roads, and other local use or occupancy lines and corners of the boundaries of claims are also shown.
- (2) The narrative includes a description of the recovered evidence and statements by witnesses regarding obliterated corners. The extent of obliteration and the degree of faithfulness of the original survey is discussed when this is pertinent. Disposals made by the Federal Government, in fee or less than fee, are described, and Federal interest lands are listed by administrating agency and, if practicable, are shown on the diagram as well. Mention is made of improvements potentially affected by the resurvey, the evidentiary basis of claim locations, the degree of faithfulness of claim locations and local surveys to original survey evidence and between or among themselves, conflicts between claims, and any hiatus that may be anticipated.

- (3) The field notes of the retracement form an important part of the report, since the field notes show how correctly the natural features were represented in the original record.
- (4) Finally, the surveyor recommends the procedure that will best deal with the existing conditions.

The report of the field examination is reviewed in the supervising office. Special instructions (or supplemental special instructions) are written to show the detail of the proposed resurvey. If the independent method is selected, an important consideration is the fixing of the out-boundaries of the sections, township, or townships within the planned resurvey. These limiting boundaries must be lines that can be restored in such a manner as to protect existing rights in the adjoining outside lands. An exception is where such a large area is to be independently resurveyed that it cannot all be included in one assignment. Occasionally, one portion of a township can be dependently resurveyed, while an independent resurvey is necessary in the remaining portion. In such a case the subdivisional lines separating the two types of resurvey must be dependently resurveyed.

**5-34.** Even when the procedures have been based on a preliminary examination, unforeseen difficulties may occur during the progress of the resurvey due to the greater detail of the work. The new factors may make the special instructions inapplicable. If this occurs the surveyor should suspend further monumentation, report the situation promptly to the supervising office, describe the nature of the difficulties, and request further instruction. Attention may be given to any additional retracement or other examination required.

**5-35.** During the course of a resurvey the surveyor should advise all interested parties, as occasion and opportunity allow, that the resurvey is not official or binding upon the United States until it has been duly accepted for the Director, Bureau of Land Management, and officially filed as provided by law. It is subject to change or correction, and therefore no alteration in the position of improvements or claim boundaries should be made in advance of the official filing of the resurvey.

## The Dependent Resurvey

### General Rules

**5-36.** A dependent resurvey is an official re-marking of the original lines upon a plan whereby the best available

evidence of the original survey or of a prior resurvey is given primary control over the position of the lines to be reestablished. The dependent resurvey is designed to restore the original conditions of the official survey according to the record. It is based, first, upon identified and found original corners, second, other acceptable points of control including “obliterated corners,” and, third, restored “lost corners” by proportionate measurement in harmony with the record of the original survey. Some flexibility is allowable in applying the rules of proportionate measurement and subdivision of sections in order to protect the bona fide rights of claimants. This is particularly so in those cases where no objection is found to adopting a point acceptably located under the good faith location rule, and only slightly at variance with the theoretical position computed from the primary control.

**5-37.** The dependent resurvey is commenced by making a retracement of the township exteriors and subdivisional lines of the established prior survey within the assigned work. Concurrently, a study is made of the records of any known supplemental surveys, and testimony obtained from witnesses to ascertain if this collateral evidence is sufficiently well-qualified to support the identification of obliterated corners. A retracement of lines first run by local surveyors that may affect the resurvey is begun to ascertain if this evidence is sufficiently well-qualified to support the identification of obliterated corners or the location of legal subdivisions.

The retracement leads at once to identification of known and plainer evidence of the original survey. A trial calculation is made of the proportionate positions of the missing corners, followed by a second and more exhaustive search for the more obscure evidence of the original survey. If additional evidence is found, a new trial calculation is made.

**5-38.** A comparison of the temporary points with the corners and boundaries of alienated lands often helps in determining how the original survey was made, how the claims were located, or both. In analyzing the problem, in developing search areas for a particular corner’s location, and in weighting the collateral evidence, it is often helpful to determine where the theoretical corner point would fall using various methods. In the case of an interior section corner, for example, three-point or two-point control, particularly when supported by field-note calls to well-identified natural features may prove to be the best method to reestablish the position of the original corner, or prove that a corner, which would otherwise be lost, has been perpetuated by an acceptably located claim.

**5-39.** Ordinarily, one-point control is inconsistent with the general plan of a dependent resurvey. The courts have sometimes turned to this as the only apparent solution of a bad situation, and unfortunately this has been the method applied in many local surveys, thus minimizing the work to be done, and the cost. Almost without exception, the method is supported to the degree that “it follows the record.” This overlooks the fact, however, that the record is equally applicable when reversing the direction of the control from other good corners, monuments, or marks.

The use of one-point control to reestablish a lost corner is strictly limited as delineated in section 7-56. However, another use of the concept is to develop corner search areas. This is appropriate in areas of evident unfaithfulness in execution of the original survey where the evidence suggests the possibility of an original corner having been established by one point control despite records indicating otherwise. These are calculated at record bearing and distance from each adjacent corner, with an index correction if applicable.

**5-40.** At this stage of the field work, the surveyor should exhaust every possible means of identifying the existent or obliterated corners from direct evidence of the original survey. Once this has been accomplished, attention may be given to the adoption as an integral part of the dependent resurvey system, of corner positions determined by evidence of a lesser character, including witness statements and acceptable local survey corners of claim locations. Such evidence, termed “collateral evidence” is combined with the direct evidence of the original survey to give the basic control for the resurvey. All local corners not adopted will be noted in the record.

**5-41.** The process and governing rules of the dependent resurvey comprehensively bring into consideration the position of recognized land boundaries in the absence of direct evidence of the original corners. Chapter VII is specific regarding the application of the rules of proportionate measurement for the determination of the theoretical positions of lost corners. These rules will be applied in the dependent resurvey generally with respect to the township as a unit. The surveyor must exhaust the means of identification of each and every existent and obliterated corner and the theoretical position will be determined for each lost corner. The existent or obliterated corners are to be considered as fixed points (except in the most unusual cases) and may be monumented at any time. The lost corners will be subjected to the possible influence of points that may afterwards

be determined to be acceptably located under the good faith location rule, and should be marked only as temporary points until this question has been resolved.

**5-42.** In the absence of other considerations the theoretical points determined by proportionate measurement and based upon existent or obliterated original corners are fixed to a mathematical certainty and then the surveyor is prepared to consider the weight of such collateral evidence as may be available.

**5-43.** In the plan of dependent resurvey, the surveyor must remember that the lengths of lines, when subject to double proportion, are comparable only when reduced to cardinal equivalents (section 7-9) or to equivalents along the direct lines between the nearest existing corners.

**5-44.** The final calculations for the corners that are to be treated as lost is based upon the known position of the corners of the general control as adopted and proportionate measurement, as provided in chapter VII. The result of this process balances in regular proportion the differences between the measurements shown in the record of the original survey and those derived in the retracement. Thus, the true lines of the dependent resurvey are determined through the influence exercised by the identified existent and obliterated corners of the original survey, other identified calls of the record, and such collateral evidence of the position of recognized land boundaries as may properly be adopted for such influence.

**5-45.** Any marks made either before or subsequent to the official survey, or at the time of the survey but not under the direction of the chief of field party, are not to be regarded as evidence of that survey except when authenticated by field notes or qualified testimony. Reference will be made in the field notes, however, if the marks are of a permanent nature. If such marks or monuments are rejected, the reason will be shown by the new record.

**5-46.** The surveyor should make certain while still in the field, that complete descriptions of all identified, accepted, rejected, or nonaccepted corners have been noted for entry in the official record of the resurvey so that the record will embrace:

- (1) A complete description of the remaining evidence of each original monument;
- (2) A complete description of the original accessories as identified;

- (3) A concise statement relating to the recovery of a corner based upon identified line trees, blazed lines, items of topography, or other calls of the field notes of the original survey, in the absence of evidence of the monument or its accessories;
- (4) A statement of the determining features leading to the acceptance of a recognized local corner;
- (5) A complete description of the new monument(s);
- (6) A complete description of any new accessories; and
- (7) A complete description of rejected and nonaccepted local corners and accessories with a statement of the determining features leading to their rejection or nonacceptance.

### Reestablishment of True Lines

**5-47.** The running and measurement of the true lines of the dependent resurvey, the marking of lines between corners, the notation of objects to be recorded, and the monumentation of the survey must conform to the requirements for original surveys and to the special instructions. The official record of the resurvey shows the relationship between the original survey, prior resurveys, and the reestablished lines.

**5-48.** In the course of marking the true lines, it is often desirable to establish sixteenth-section corners or minor subdivision corners that control the position of intermingled Federal interest land within a section. Later subdivision of the section would then not require a new dependent resurvey of the section lines for that purpose. This will be addressed in the special instructions or the supplemental special instructions.

Reasonable discrepancies between former and new measurements may generally be expected when retracing the section boundaries. The shortage or surplus is distributed by proportion in establishing a sixteenth-section corner. For example: The length of the line from the quarter-section corner on the west boundary of section 2 to the north line of the township, by the official survey was reported as 43.40 chains, and by the surveyor's measurement was found to be 42.90 chains. The distance at which the sixteenth-section corner should be located north of the quarter-section corner would be

determined by proportion as follows: As 43.40 chains, the official measurement of the whole distance, is to 42.90 chains, the surveyor's measurement of the same distance, so is 20 chains, original measurement, to 19.77 chains by the surveyor's measurement. By proportionate measurement in this case the sixteenth-section corner should be set at 19.77 chains north of the quarter-section corner and not 20 chains north of said corner, as represented on the official plat. In this manner the discrepancies between original and new measurements are equitably distributed.

**5-49.** The limit of closure already prescribed will be observed, unless modified in the special instructions. Special stress will be given to the need for greater accuracy in the measurements, which largely govern the restoration of lost corners, or the placement of monuments marking corners for the first time.

## The Independent Resurvey

### General Rules

**5-50.** The independent resurvey is used when the original survey cannot be identified with any degree of certainty in accordance with the representations of the official record, especially where there are considerable areas of Federal interest lands. An independent resurvey may be required where the prevailing conditions are such that strictly restorative processes, when applied as an inflexible rule between existing monuments or adopted corner positions, are either inadequate or lead to unsatisfactory results. If it is decided to supersede the record of the original survey with respect to the remaining Federal interest lands, an independent resurvey is appropriate.

This type of resurvey provides for the protection of existing bona fide rights by segregating individual tracts or conforming them to the subdivisions of the dependent resurvey if that can be done suitably. Generally, tract surveys can be avoided by restoring the section boundaries in which the claim is situated, using the same control that would have been employed to govern the tract survey. The control may be locally recognized corners, three-point, two-point, or even one-point control.

In effect this may employ both types of resurvey, dependent and independent, in the same township, with the dependent resurvey covering those sections that include alienated lands. Tract segregation is necessary only in those unusual cases where unrelated control prevents the



reconstruction of sections that would adequately protect the alienated lands, or where the resultant plat would not constitute an acceptable basis for the identification of the remaining Federal interest lands.

**5-51.** These processes are found to be more flexible in their application than those of the strictly dependent type, but at the same time they are intended duly to protect all bona fide rights that have been acquired upon the basis of a prior survey(s). The independent resurvey supersedes the record of the survey with respect to the identification and description of the remaining Federal interest lands. This will be clear by the representations of the approved and filed resurvey plat.

**5-52.** An independent resurvey can include an official running and marking of new township and section boundary lines without regard for the location of the record lines and corner monuments or other marks of the prior official survey that the independent resurvey is designed to supersede. The new lines may be effective only insofar as the remaining Federal interest lands are concerned. The subdivisions tentatively approved, interim conveyed, claimed, entered or patented at the time of the resurvey are in no way affected as to location. All such claims must be identified on the ground then protected in one of two ways. First, and whenever possible, the sections in which claims are located are reconstructed from evidence of the record survey just as in a dependent resurvey. Second, where unrelated control prevents the reconstruction of the sections that would adequately protect them, the alienated lands are segregated as tracts.

**5-53.** Tract segregation does not change the location of any conveyance from the Federal Government. Tract segregation is designed to give official recognition and respect to all rights as to location, shape, and size of the conveyance. The tract segregation platting process should clarify the land description. One or more tract boundaries may be identical with the corresponding new legal subdivisions of the independent resurvey. The conformance process can clarify a description that cannot be identified with certainty in one position to the exclusion of another. A description conformed to a survey cannot change its location, but can clarify that location.

A tract so segregated is identical with the lands of a specific description based on the plat of the prior official survey. The tract segregation merely shows where the lands of this description are located with respect to the new section lines of the independent resurvey. In order to avoid confusion with section numbers, the tracts are

designated beginning with number 37 or the next number above the highest tract number already used. The plan of the independent resurvey must be such that no lines, monuments, or plat representations duplicate the description of any previous section where disposals have been made. Thereafter, the new legal subdivision lines become the prevailing survey for every purpose of identification and description of the Federal interest lands involved.

**5-54.** Where this flexibility in the application of surveying rules is involved, such as in restoring the section line boundaries with less than normal control or in making tract segregations in an independent resurvey, it must be clearly recognized that the authority to review the effect of an independent resurvey upon the location of the boundaries of privately owned land rests in the courts. A decision of the court is binding in fixing a boundary between private lands. However, in fixing a boundary between Federal and alienated lands, monuments of the official survey must be considered as the court has no authority to set aside the official survey.

**5-55.** The independent resurvey is accomplished in four distinct steps:

- (1) The reestablishment of the outboundaries of the area to be resurveyed, following the methods of a dependent resurvey.
- (2) The segregation of lands embraced in any valid claim based on the former approved plat.
- (3) The survey of new exterior, subdivisional, and meander lines by a new regular plan.
- (4) Linking the description of the segregated tracts back to the original description in the conveyance document. This should include careful coordination with the appropriate lands staff of the administering Federal agency.

### Reestablishment of Outboundaries

**5-56.** The outboundaries of the lands that are to be independently resurveyed must agree with the previously established and identified exterior or subdivisional lines of the approved original surveys. In order to qualify as a suitable limiting boundary, a line of the accepted established surveys must be conclusively identified in one position to the exclusion of all others and must by its known position adequately protect all rights located in good faith based upon any official plat showing subdivisions of the



lands adjacent to said boundary. Such outboundaries of the lands to be resurveyed by the independent process must necessarily be retraced and reestablished in their true original position. The lands on one side of the outboundary are to be resubdivided upon a new plan. On the opposite side the original subdivisions are to be strictly maintained, and none of the original conditions are to be disturbed. Where an outboundary has been reestablished by dependent resurvey, the subdivisions of a tract originally described as along or on opposite sides of the outboundary must agree with the line thus reestablished.

**5-57.** Although the outboundaries of the independent resurvey generally follow established township exteriors, section lines may qualify as suitable limiting boundaries. Such section lines must then be duly retraced and reestablished in their true original position. Particular attention should be given to this subject when the field examination is made, with a view to maintaining the original survey as far as it is consistent.

**5-58.** In some cases a proper outboundary cannot be secured without including a greater number of townships than it is practicable to resurvey in one assignment. One or more tracts requiring segregation may then extend across a group outboundary into a township not grouped for resurvey. Any such tract will be fully segregated whether or not the tract was originally described as in the township to be resurveyed. The necessary official steps will be taken to suspend disposals, leases, orders and other land or resource transactions in the adjoining township pending investigations with a view to the resurvey of that township.

Where the projections of new lines of the independent resurvey are not to be initiated or closed upon the restored original corners of the outboundaries, the new monuments will be marked only with reference to the township, range, and section to which they will thenceforth relate. New regular corners controlling the lines of the independent resurvey will be established as provided in sections 3-40 through 3-49 under "Defective Exteriors." During the preliminary stages of the resurvey there will often be doubt as to whether an old corner will retain its former control or not. The marking of the new monument and its accessories may be deferred until the future significance of the point is determined. Where an old point is not to be the corner of a subdivision, but is to be perpetuated merely to control alinement, it should be monumented as an angle point.

**5-59.** The special instructions will show specifically what lines have been selected to limit the independent

resurvey. The dependent resurvey will be restricted to those sections where the retracements indicate that some suitable control can be applied for the restoration of those section boundaries. The retracement and reestablishment of the outboundaries of those sections will be the exterior of the dependent resurvey; this should precede the running of the new lines, the latter being devoid of adequate control that can be derived from the prior survey.

**5-60.** A special problem is presented in those situations where the appropriate Chief Cadastral Surveyor finds that it is advisable to cancel an official survey because of the showing of gross irregularities beyond any tolerable limit, such as badly distorted section boundaries whose lengths and directions are unreasonably at variance with the record, or the fact that some of the lines are fictitious or fraudulent such that they never had actual existence in fact. The cancellation action can be taken only in the name of the Director, and requires ample justification to show that even though the monuments can be identified in portions of the area, the lines when restored under the rules for proportionate measurement do not constitute an acceptable basis for the identification of the remaining Federal interest land. This applies to the Federal interest land only and has no bearing on the identification of the alienated subdivisions described in terms of the prior survey.

The cancellation of an official survey that is marked on the ground requires that the location of the existing monuments be determined by direction and length of line connecting to the nearest new monuments, then treated as amended monuments (see section 3-40).

**5-61.** A factual statement will be required in the field-note record of the independent resurvey to show what proof has been established that no corner monuments have been overlooked, disregarded, or otherwise ignored. There is always risk of failure to find some of the record monuments. If that occurs, confusion can result from the existence on the ground of two sets of monuments that, by record, exist to mark similarly described subdivisions. Every effort should be made to avoid this outcome.

### **Tract Segregation: Tract Survey and Description of Alienated Lands**

**5-62.** The special instructions must designate the sections containing alienated lands that will be dependently resurveyed. Where there is acceptable evidence of

the original survey, the identification of the areas that have been disposed of must be the same as would ordinarily be derived by the regular subdivision of the section. Areas to be segregated by survey and described as tracts are (1) those areas that cannot be so identified, nor conformed satisfactorily, (2) those areas where correction of conveyance document appears not to be an available remedy, and (3) those areas where the disposals are found to be in conflict by overlap. Every corner of these tracts is marked by angle-point monumentation, and a tie is made from each tract to a corner of the resurvey.

**5-63.** An abstract of pertinent records and a status diagram will be furnished to the surveyor showing lands whose boundaries cannot legally be disturbed. These include patented lands, valid entries or claims, school sections, land grants, tentative approvals, interim conveyances, disposals, reservations, or selections of lands whose position and description are based upon the original survey and plat subject to dependent resurvey. The resurvey will not be complete until each claim described has received full protection in the matter of location. Each must be protected either by individual tract survey and description or by the assignment of subdivisions of the independent resurvey whose boundaries coincide or approximately agree with the tract boundaries. In addition, the surveyor will be furnished with the status of all claims in the adjacent sections or adjoining townships not grouped for resurvey that might affect the resurvey procedure. The title status will be included with the other data to accompany the special instructions providing for a resurvey.

**5-64.** The survey of alienated lands need not be completed before beginning the projection of the new lines of the independent resurvey. It is logical, however, to consider the subject of the tract segregations in advance of the question of the establishment of new lines. The surveyor may find it expedient to carry both branches of the survey along together.

However, before making tract segregations and before the running of new section lines, make certain the discrepancies are such that no adequate or satisfactory basis can be shown for the restoration of the former section-line boundaries as a whole. The plan of the independent resurvey will be such that no lines, monuments, or plat representations will duplicate the description of any previous section where disposals have been made. With the filing of the resurvey, the record field notes and plat representing the prior survey are cancelled, and must not be used for any future disposals, leases and other land or resource transactions.

**5-65.** The following rules will be observed in developing the survey and description of designated tracts:

(1) Each acceptably located claim that is at variance with the lines of the independent resurvey is surveyed and monumented at each angle point.

(2) Where the limiting boundary of the independent resurvey has been reestablished in its original position by dependent resurvey, the portion of a claim lying outside the outboundary is not surveyed as a tract. It is located in an area where the original conditions cannot be disturbed. The portion of the claim lying within the area of the independent resurvey has at least one identifiable original boundary. It should be defined by segregation or conformation to the lines of the independent resurvey in a position that is properly related to the identified or restored corners on the outboundary.

(3) Where the boundaries of a claim are unacceptably located as pointed out by the claimant, the claim is surveyed and monumented in a suitable relation to the original survey. If the claimant protests the location, the surveyor will request that the protest be made in writing. The written protest will be submitted with the returns of the resurvey. Accurate ties will be made to the corners of the claim as unacceptably located. The surveyor will make a complete report of the facts with reference to the question of location. Further protection to the entryman may be sought by an amendment of entry, correction of conveyance document, tentative approval relinquishment, or interim conveyance reconveyance or relinquishment.

(4) Where the tract segregation of a claim (or its conformation to the lines of the independent resurvey) does not cover the lands occupied, improved, or claimed, the claimant may express a desire to amend the entry, tentative approval, interim conveyance, or seek a correction of conveyance document. The fact should be stated in the field notes. A separate full report is made by the surveyor describing the subdivisions actually occupied and those sought under the amendment or correction that are not within the tract as surveyed, all looking to the protection of the title to the lands actually earned. (See current regulations

relating to the amendment of entries, tentative approvals, interim conveyances, or correction of conveyance documents.)

(5) Where the regular quarter-quarter sections embraced within a claim fall in approximately the same position as the regular quarter-quarter sections of the independent resurvey, the claimant, entryman, or patentee may desire to conform the claim to the independent resurvey. If no apparent objection is found by the surveyor, the facts should be stated in the field notes and the claim so indicated upon the resurvey plat. The desire by the claimant, entryman, or patentee to conform the claim to the independent resurvey should be documented as testimony and included in the field notes. Under this circumstance the tract survey is omitted. However, where a tract includes an irregular lot as originally described or where any part of a tract falls upon an irregular lot of the dependent resurvey, the tract will be segregated as a whole, even though some or all of the lines of the tract may coincide with certain subdivisional lines of the independent resurvey.

No claim should be conformed to the lines of an independent resurvey under an involved amended description that includes numerous subdivisions smaller than the regular quarter-quarter section, excepting as completely surveyed and monumented.

(6) Conflicting tracts, each acceptably located, are surveyed and monumented and the conflict shown upon the resurvey plat. Each intersection of conflicting boundaries is determined upon the ground and recorded in the field notes. The number of acres in conflict with each other tract will be shown in the field notes, or on the plat, or both.

(7) The angle points of a tract are designated by serial numbers beginning with No. 1 at the northeast corner, and proceeding around the claim, running westerly from the initial corner. An angle point may be common to one, two, three, or four tracts. The monument is marked as in the examples in section 4-49.

(8) No accessories are required with the monuments at the angle points of the tract survey.

(9) At least one angle point of each tract is connected with a regular corner of the independent resurvey. Where claim lines are intersected by lines of the independent resurvey, a connection is made to the nearest claim corners on each side of the intersection and recorded in the field notes of the section line. This is considered a satisfactory connection to all adjoining claims located within the interior of either section. Where an extensive system of tract segregations has been surveyed, the interior tracts of the block do not require connections. The establishment of monumented corners on the regular line when entering or leaving Federal interest land will conform to the practice described in sections 3-74 through 3-79.

(10) All recovered monuments of the original survey, including line trees and witness points, not otherwise reported upon are connected by course and distance with a corner of the independent resurvey. The connection and a description of the traces of the original corner as identified are recorded in the field notes of the resurvey. The old monument is marked AM (for amended monument) inverted and buried in place, if practicable, and the accessories are effaced unless the point may be needed to control the position of a claim.

### The Projection of New Lines

**5-66.** A plan for projecting new section lines for the identification of the remaining Federal interest lands can best be made after study of a layout showing (1) lines of the former survey that are to be restored, and (2) the necessary tract segregations. Ideally, the new subdivision lines should be placed to maximum agreement with the boundary positions of conformable claims while eliminating or reducing the necessity for tract segregations, where this can be accomplished in harmony with the rules previously outlined. The report of the field examination should be explicit and include a plan for incorporation into the special instructions. If the report does not fully identify the position of alienated lands, the plan must be delayed until these lands have been identified.

**5-67.** The resubdivision of remaining Federal interest lands in a township by independent resurvey is an application of completion subdivision as discussed in sections 3-97 through 3-98. However, an independent resurvey may involve the resubdivision of a group of

many townships where the conditions are comparatively regular except for the tract segregations. After having reestablished the outboundaries of the group on the dependent plan, first attention is given to completing the township exteriors that are to be independently resurveyed. These new township exteriors are completed as in the establishment of original surveys. The new section lines are surveyed and marked as in regular or fragmentary subdivision, whichever may be the case. New meander lines are run as required. The new exterior and subdivisional lines are usually extended across small blocks of tract segregation surveys, and connections are made as described in section 5-65(9). Where the new lines are so extended across tracts, the corners are fully monumented regardless of the fact that some points fall within the tract segregation surveys. They are required in order to determine the proper subdivision of the Federal interest land.

**5-68.** A general exception to the rule of extending the new lines across the tract segregations may be made in those townships or portions of townships that are so densely covered by private claims that the remaining parcels of Federal lands may be as well or better identified and described using isolated tract numbers. In such cases monumented corners will be required after a retracement of the private claim lines when entering or leaving Federal land. The new lines may be extended as blank lines across the tract segregations, according to the plan of running the new section lines of the independent resurvey. Where this method is employed, it will be necessary to assign tract numbers to the parcels of Federal interest land and to mark the angle points accordingly. Where a parcel of Federal interest land is to be identified using this plan, such tracts will be surveyed and described in accordance with the usual rules.

**5-69.** In rare cases certain quarter-quarter sections of Federal interest lands, in accordance with the system of the original survey as indicated by adjoining tract segregations, may be segregated to afford an improved basis of administration. Such segregations should not be made unless it is conclusively shown by the surveyor that the lots and regular quarter-quarter sections of the independent resurvey are inadequate as a basis of disposal, leases or other transactions under existing conditions of occupancy on the part of settlers, entrymen, or claimants who may propose to conform, amend, reconvey, relinquish, or seek a correction of conveyance document. The special instructions will be made as explicit as possible in these details and determined when the plan of the resurvey is under consideration by the supervising officer.

**5-70.** After the plan of running new section boundaries has been determined, the creation of needed new lottings is considered. This will precede the marking of the corner monuments, which may be affected by the manner in which the lots are laid out and numbered.

Where any aliquot part (not alienated) of a newly created section would normally have a description that duplicates the corresponding part (alienated) of an original section bearing the same section number, such part or parts of the new section are given appropriate lot numbers. The new lot numbers begin with the next number above the highest numbered lot of that section of the prior survey. Also, where there are new regular lottings in the sections along the north and west boundaries of the township, if those sections are not restorations of the corresponding sections of the prior survey (and same township and range) the lottings are given numbers beginning with the next higher number above those that were previously employed.

**5-71.** Some new sections may be elongated in order to absorb the discrepancy in the positions of the section line boundaries as between the old and new survey, or as part of the conformance process. This is taken care of in the lottings of the new sections. Such departure from normal procedure is made necessary by the discrepancies of the prior survey, where the location of the alienated lands cannot be changed.

A departure from the usual rule for lotting is necessary in order to provide unambiguous descriptions of unpatented entries, claims, selections, tentative approvals or interim conveyances where such tract segregations may be subject to relinquishment, cancellation, abandonment, or forfeiture. In other cases, this revised lotting method may facilitate the subdivision of isolated tracts of Federal interest lands. Two methods of lotting have thus been developed for use in particular situations. Neither method involves any change in the instructions for the field procedure heretofore laid down. The discussion of the relative merits of the two methods and the examples of their use are described in sections 9-140 and 9-141.

**5-72.** Where a section of the independent resurvey is invaded by tract segregations, the lotting of the Federal interest lands is carried out in accordance with the usual plan of lotting within irregular sections. The numbering of the lots begins with the number next higher than the highest number employed in the section of the original survey that bears the same township, range, and section number. This plan avoids any possible confusion that might arise from duplicate lot numbers.



**5-73.** The plan of the independent resurvey should be carefully studied for proper placement of all needed quarter-section corners, for either one or two sections, so as to provide for the position of the center lines of all sections, restored or new. Where two positions for quarter-section corners are found to come within less than half the closing limit prescribed for a section by special instructions, the point first derived as the appropriate position of the quarter-section corner of the restored section boundary is used for control in both sections. This rule is in the interest of simplicity of survey and monumentation.

**5-74.** The general requirements of chapters II, III, and IV will be fully observed in every respect throughout the execution of the independent resurvey.

During the period of the field work and the construction of the resurvey plats, the surveyor must make certain that every possible condition has been given consideration and that all necessary data have been obtained.

## Special Cases

**5-75.** Experience, thoroughness, and good judgment are indispensable for the successful retracement and recovery of any survey when it reaches a stage of extensive obliteration, when there is manifest distortion, or when there are years of unofficial boundary determinations resulting in confused and conflicting lines and corners. It is an axiom among experienced cadastral surveyors that the true location of the original lines and corners can be restored, if the original survey was made faithfully and was supported by a reasonably good field-note record. That is the condition for which the basic principles have been outlined, and for which the rules have been laid down. The rules cannot be elaborated to reconstruct a grossly erroneous survey or a survey having fictitious field notes. The methods applicable to dependent resurveys, as outlined in chapter VI, are designed to rectify conditions at variance with the representations of the official survey record.

**5-76.** The records of official resurveys cover many special cases. The records in the BLM Cadastral Survey offices include the special cases from all public land States. These plats, field notes, reports of office and field examinations and investigations, office opinions, Departmental decisions, opinions from the Solicitor or Attorney General of the United States, court opinions and decrees, and administrative land law decisions are drawn upon when needed to assist the surveyor in the

study of situations that are new to the surveyor's experience. In administrative appeals of official surveys and trials of boundary suits, the board or court often consider many additional questions besides the purely technical. To do justice, the surveyor often finds the proper decision lies in the realm where technical and nontechnical matters overlap. When the surveyor encounters unusual situations, or finds it difficult to apply the normal rules for good faith location or restoration of lost corners, the surveyor will report the facts to the proper administrative office. If it is determined that additional retracements are necessary, these should be provided for by supplemental special instructions.

## Resurvey Summary, Including Subdivision of Sections

**5-77.** A summary of the theory and practice of the resurvey and survey of sections reveals certain minimum requirements:

- (1) The need for care in the determination of the length of lines, which is so largely controlling in the restoration of lost corners, and for care in the determination of the basis of bearings, which so largely controls the establishment of corners by intersecting lines and the abstraction of survey data into digital formats, cannot be overemphasized.
- (2) The rules for the identification of existent corners, the acceptance of collateral evidence with respect to obliterated corners, the restoration of lost corners, and the evaluation of local points of control will be followed specifically as outlined in chapters VI and VII.
- (3) The monumentation in all respects is as required on original surveys, supplemented by a field-note record of all necessary descriptions, including the prior monumentation as identified by the physical evidence, the collateral record, and the monuments as reconstructed.
- (4) In order to accomplish a resurvey, the section boundary lines are first retraced in their entirety or as needed to mark the boundary of the Federal interest lands, and restored in their original position, as nearly as practicable. This circumscribes the work to be done, and is usually carried out on that plan unless some condition is



developed that requires supporting evidence that may be derived from the subdivisional surveys within the section or adjoining sections before concluding the restoration of the section exterior and the marking of lines and corners.

(5) There follows a complete survey of the center lines of the section, the survey of the center lines of the quarter-sections and lines interior to each quarter-quarter section as needed to mark the boundaries of the Federal interest lands as nearly as practicable, to completely ascertain the lines as returned by the original plat. This circumscribes the work to be done, and is usually carried out on that plan unless some condition is developed that requires supporting evidence that may be derived from the local conditions.

(6) In practice, and as applied to the very early original surveys that were in some cases performed more than 200 years ago, where dependent resurvey is required, the surveyor usually must be concerned with three primary elements, which it is his or her responsibility to harmonize as far as that can be done along legal methods, though the surveyor is not clothed with legal jurisdiction to dispose of disputes. The surveyor's job is to ascertain the facts in each situation, and render a representation and mark the boundaries of Federal interest lands. This involves the primary elements of: first, restoring what the written record and physical evidence purport to be the original conditions; second, protecting the bona fide rights of all claimants in the matter of their locations; and, third, marking the boundaries of the Federal interest lands.

(7) In practice, and as applied to the very early local surveys made, in some cases, more than 200 years ago, where local conditions will influence the required dependent resurvey, the surveyor usually must be concerned with harmonizing these same three primary elements. However, in restoring what the written record and physical evidence purport to be the original conditions, emphasis is placed on protecting the legal subdivisions as shown on the original plat.

(8) The first requirement in the dependent resurvey of the section exterior must be fulfilled with reference to the evidence of the original survey where the discovery and identification of original monuments, marks, and corner positions

is paramount. In this context, it should be borne in mind that frequently there may be only a few remaining original marks and that each additional increment of supporting evidence adds appreciably to the conclusiveness of the resurvey and contributes to its basic control.

(9) The first requirement in the survey of the section interior must be fulfilled with reference to the evidence of the original survey as represented on the original plat. This stage of the survey further develops the basic control.

(10) The cadastral surveyor is in the same position as the local surveyor, and is bound by rules governing restoration of the original survey, determination of acceptable location of local points of control, questions of good faith locations, and recognition of special cases. The county surveyor may enlist the assistance of the county attorney, or the local court as needed; the cadastral surveyor reports to the appropriate chief cadastral surveyor who should consult with the Office of the Solicitor when in doubt as to procedure. The advice or instructions that follow in either case must necessarily depend upon the facts as reported by the surveyor. If the surveyor fails in his or her work, by oversight, carelessness, or inexperience, the BLM office, the Office of the Solicitor, the local attorney, or the court may be thereby misled, and the treatment of the situation may be entirely inappropriate. This responsibility on the part of the assigned surveyor demands utmost thoroughness in every detail.

(11) To properly mark the boundary of the remaining Federal interest lands, including Indian lands, the official survey process combines issues of ownership with boundary. It is emphasized that Federal authority surveyors who have been in private practice must bear in mind that in their official capacity they act under somewhat different rules of law than the State laws governing the registration and practice of land surveying. They must carefully distinguish between the role of the local surveyor as set forth by State statute, from the role of the cadastral surveyor who bears the delegated responsibility to determine and mark what are Federal interest lands, what lands have been surveyed, what are to be surveyed, what have been disposed of, what remain to be disposed of, and what are reserved,

all such surveys being subject to review, approval and official filing, as established by the United States Congress.

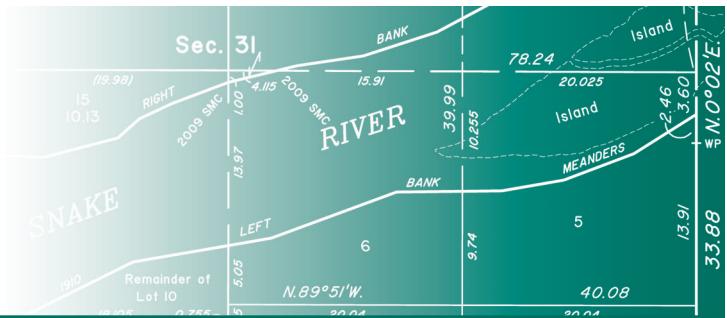
(12) An outline of the subject of retracements, entirely advisory in character, for the information of county and other local surveyors, with a brief reference to property rights under State law, is

contained in the Manual supplement *Restoration of Lost or Obliterated Corners and Subdivision of Sections*. The cadastral surveyor is bound by the same rules when engaged in official surveys. There is sometimes an apparent overlap in jurisdiction, but in most cases the distinction in the duties is clear.



## Chapter VI

# Resurveys and Evidence



## The Nature of Resurveys

**6-1.** The rules for identifying the lines and corners of an approved official survey differ from those under which the survey was originally made. The purpose is not to “correct” the original survey by determining where a new or exact running of the line would locate a particular corner, but rather to determine where the corner was established in the beginning. There is no realm of the law in which there is a greater need to maintain stability and continuity than with regard to property rights and the location of real property boundaries. This requirement is explicitly expressed in the Act of February 11, 1805 (2 Stat. 313; 43 U.S.C. 752):

- (1) All the corners marked in the surveys, returned by the Secretary of the Interior or such agency as he may designate, shall be established as the proper corners of sections, or subdivision of sections, which they were intended to designate;
- (2) The boundary lines, actually run and marked in the surveys returned by the Secretary of the Interior or such agency as he may designate, shall be established as the proper boundary lines of the sections, or subdivisions, for which they were intended, and the length of such lines as returned, shall be held and considered as the true length thereof.
- (3) Each section or subdivision of section, the contents whereof have been returned by the Secretary of the Interior or such agency as he may designate, shall be held and considered as containing the exact quantity expressed in such return;

**6-2.** Surveyors with extensive experience working in the non-Federal arena are especially cautioned that the stability envisioned by this statutory scheme may be different from the concept of stability described in common law boundary cases. Stability of boundaries

in the non-Federal arena is often given as the guiding principle behind boundary resolution theories such as adverse possession or acquiescence. The Federal statutory scheme quoted here, however, does not seek to reward a landowner who merely maintains an enclosure or improvement for a long period of time. In fact, principles of “adverse possession” do not apply against the United States. Rather, stability is inherent in protecting the integrity of the lines actually run and marked in an official survey. Thus, a paramount principle is that all evidence gathered, whether direct or collateral, be analyzed with a view toward discovering the best available evidence of the official survey lines. Evidence of a private property line is valuable in this process only insofar as it can be related, by substantial evidence, to the official survey. The methods described here follow leading judicial opinions, administrative law decisions and approved surveying practice.

**6-3.** The Cadastral Survey Program of the Bureau of Land Management (BLM) is responsible to identify the initial lines, the subdivision of these areas, the determination of the area within such surveys, and the preparation of the official plat and written record of the public land survey system. Congress has empowered the Secretary of the Interior, or such officer as he or she may designate, to perform all executive duties appertaining to the survey of Federal interest lands (43 U.S.C. 2), including Indian lands (25 U.S.C. 176). The records of official surveys fall under the doctrine of presumption of regularity; that is, the official record is correct unless it is established otherwise by a preponderance of the evidence.

**6-4.** Where Federal interest lands are involved, including Indian lands, the final authority to approve or disapprove the official resurvey procedures rests with the Secretary, acting through the Director, BLM. If privately owned lands are involved, consideration is given to any protest made by an interested person concerning the work of a surveyor authorized by the BLM. However, the Director cannot assume jurisdiction over or responsibility for the acts or results of surveys made by county, local, or private surveyors, or by surveyors

or engineers who may be employed by other branches of the Federal Government as such surveys were not conducted under the direction and control of the Chief Cadastral Surveyor.

On the other hand, it often falls to the county or other local surveyor to mark the corners of subdivisions of sections and the location of private property lines, and where a required corner is obliterated, the local surveyor may be called upon to recover the point. Thus it will be seen that local surveyors as well as cadastral surveyors of the BLM are constantly called upon to search for existing evidence of original monuments, and in this work the surveyors should be guided by the same general methods. The text that follows draws no distinction between these duties of the two classes of surveyors.

**6-5.** Although this guidance pertains especially to the dependent resurvey of an original survey, the same principles apply to the dependent resurvey of an official resurvey, and to the resurvey of a local survey. Official resurveys and local surveys subsequent to the original survey must be considered in context of the objectives of each Federal Government dependent resurvey. First, the adequate protection of the existing rights acquired under an original survey or resurvey and faithfully located by subsequent (re)survey as to location on the earth's surface, and second, the proper marking of the boundaries of the remaining Federal interest lands.

**6-6.** The function of the local surveyor begins when employed as an expert to identify lands that have passed into private ownership. The testimony or records of local surveyors who have identified the original monument prior to its destruction, or who have reasonably applied the good faith location rule, or who have marked the corners of legal subdivisions according to the prevailing law using the accuracy standards for the time and locale, is often considered reliable collateral evidence of the original surveyed and protracted lines and corners, particularly where those surveys are followed by use and occupancy by the landowners (section 3-132).

**6-7.** Where a corner marks the boundary between, or in any manner controls the location of the lines that form the boundary of privately-owned property, dissatisfaction on the part of or dispute between the private landowners may be brought before the local court of competent jurisdiction. The Secretary of the Interior will not be bound by a court decision purporting to affect Federal interest lands, if the United States is not a party to a suit, as least to the extent that valid evidence of the official survey was disregarded or there was some other departure from good surveying practice.

**6-8.** The terms “corner” and “monument” are not interchangeable. A “corner” is a point determined by the surveying process. A “monument” is the object or the physical structure that marks the corner.

**6-9.** The “corners” of the public land surveys are those points that determine the boundaries of the various subdivisions represented on the official plat—the township corner, the section corner, the quarter-section corner, the subdivision corner, or the meander corner.

The “mile corner” of a State, reservation, or grant boundary does not mark a point of a subdivision; it is a station along the line, although long usage has given acceptance to the term. An “angle point” of a boundary typically marks a change in the bearing, and in that sense it is a corner of the survey, as is a special survey corner, a townsite corner, and a tract corner.

**6-10.** “Monuments” of the public land surveys have included the deposit of some durable memorial, a marked wooden stake or post, a marked stone, an iron post having an inscribed cap, a marked tablet set in solid rock or in a concrete block, a marked tree, a rock in place marked with a cross (X) at the exact corner point, and other special types of markers, some of which are more substantial; any of these is termed a “monument.” The several classes of accessories, such as bearing trees, bearing objects, reference monuments, mounds of stone, buried memorials and pits dug in the sod or soil are aids in identifying the corner position. In their broader significance the accessories are a part of the corner monument.

Not all corners of the Federal surveys are monumented. Many unmonumented corners were subsequently monumented during official resurveys, or by county or other local surveyors. The monuments set during the original survey represent the highest class of direct evidence of the position of the original lines. Monuments set after the original survey may provide evidence of the original survey if set using appropriate methods for the time and with due regard for the original corner positions.

## Identification of Existent Corners

**6-11.** An *existent corner* is one whose original position can be identified by substantial evidence of the monument or its accessories, by reference to the description in the field notes, or located by an acceptable supplemental survey record, some physical evidence, or reliable testimony.



A corner is existent (or found) if such conclusion is supported by substantial evidence. The substantial evidence standard of proof is such relevant evidence as a reasonable mind might accept as adequate to support a conclusion. Substantial evidence is more than a scintilla of evidence but less than a preponderance of the evidence.

Even though its physical evidence may have entirely disappeared, a corner must not be regarded as lost, but as obliterated, if its position can be recovered through the reliable testimony of one or more witnesses who have dependable knowledge of the original position. Later marks or records that tied to the original monument or its accessories when still present, may identify the position of an obliterated corner. Such evidence should provide a direct relationship to some identifying feature described in the original survey record.

**6-12.** The process of identifying the physical evidence of an original monument is founded on the principle of intelligent search for the calls of the field notes of the original survey, guided by the controlling influence of known points. The recovery of previously established corners is simplified by projecting retracements from known points. The final search for a monument should cover the zone surrounding one, two, three, or four points determined by connection with known corners. These corners will ultimately control the relocation in case the corner being searched for is declared lost.

The search for the original monument must include a simultaneous search for its accessories. The evidence can be expected to range from that which is least conclusive to that which is unquestionable; the need for corroborative evidence is therefore in direct proportion to the uncertainty of any feature in doubt or dispute. The evidence should agree with the record in the field notes of the original survey subject to natural changes, which may vary depending upon local site conditions. Mounds of stone may have become embedded, pits may have filled until only a faint outline remains, blazes on bearing trees may have decayed or become overgrown.

**6-13.** After due allowance has been made for natural changes, there may still be material disagreement between the particular evidence in question and the record calls. The following considerations will prove useful in determining which features to eliminate as doubtful:

- (1) The character and dimensions of the monument in evidence should not be widely different from the record.

- (2) The markings in evidence should not be inconsistent with the record.

- (3) The nature of the accessories in evidence, including size, position and markings, should not be greatly at variance with the record.

**6-14.** Allowance for ordinary discrepancies should be made in considering the evidence of a monument and its accessories taking note of any pattern of discrepancies that would indicate the recorded information is unreliable. Evidence of less than workmanlike care in the original survey in compiling the record thereof has resulted in the evidence not matching the record. Examples include erroneously recorded dimensions of stones and trees; transposed or interchanged directions and/or distances to corner accessories, misidentified tree species or rock type, and inconsistencies in reporting topographical features.

**6-15.** No set rules can be laid down as to what is sufficient evidence. Much must be left to the skill, fidelity, and good judgment of the surveyor, bearing in mind the relation of one monument to another and the relation of all to the recorded natural objects and items of topography.

**6-16.** No decision will be made in regard to the restoration of a corner until every means has been exercised that might aid in identifying its true original position. The retracements will indicate the probable position and will show what discrepancies are to be expected. Any supplemental survey record or testimony must then be considered in the light of the facts thus developed.

## Identification of Obliterated Corners

**6-17.** An *obliterated corner* is an existent corner where, at the corner's original position, there are no remaining traces of the monument or its accessories but whose position has been perpetuated, or the point for which may be recovered, by substantial evidence from the acts or reliable testimony of the interested landowners, competent surveyors, other qualified local authorities, or witnesses, or by some acceptable record evidence.

An obliterated corner position can be proven by substantial direct or collateral evidence. When both categories of evidence exist, direct evidence will be given more weight than collateral evidence. A position that depends upon the use of collateral evidence can be accepted only

as duly supported, generally through proper relation to known corners, and agreement with the field notes regarding distances to natural objects, stream crossings, line trees, and off-line tree blazes, etc., or reliable testimony. Collateral evidence must include some component that relates to the position of the original survey corner, including measurement evidence, historical record, testimony, or any reasonable tie.

**6-18.** A corner is not considered as lost (section 7-2) if its position can be recovered satisfactorily by means of the reliable testimony and acts of witnesses having knowledge of the precise location of the original monument. The expert testimony of surveyors who may have identified the original monument prior to its destruction and recorded new accessories or connections is by far the most reliable, though landowners are often able to furnish valuable testimony. The greatest care is necessary in order to establish the bona fide character of the record intervening after the destruction of an original monument. Full inquiry may bring to light various records relating to the original corners and memoranda of private markings, and the surveyor must make use of all such sources of information. The matter of boundary disputes will be carefully examined as adverse claimants may base their contentions upon evidence of the original survey. If such disputes have resulted in a boundary suit, the record testimony and the court's decision must be carefully examined for information that may shed light upon the position of an original monument.

## Direct Evidence of Existent and Obliterated Corners

**6-19.** A line tree, a witness point, or a definite connection to readily identified natural objects or improvements may fix a point of the original survey. The mean position of a blazed line, when identified as the original line, may help to fix a meridional line for departure, or a latitudinal line for latitude. Such blazed lines must be carefully checked, because corrections may have been made before final acceptance of the controlling survey or more than one line may have been blazed. Thus, the mean position of a fence line or other line of use or occupancy placed with due regard to the location of the original survey and plan of survey, or whose agreement is so close as to constitute the best available evidence, may help to fix a line in latitude, departure, or both.

### Testimony of Individuals

**6-20.** The testimony of individuals may relate to the original monument or the accessories, prior to their

destruction, or to any other marks fixing the locus of the original survey. Weight will be given such testimony according to its completeness, its agreement with the original field notes, and the steps taken to preserve the location of the original marks. Such evidence must be tested by relating it to known original corners and other calls of the original field notes, particularly to line trees, blazed lines, and items of topography.

There is no clearly defined rule for the acceptance or nonacceptance of the testimony of individuals. It may be based upon unaided memory over a long period or upon definite notes and private marks. The witness may have come by his or her knowledge casually or may have had a specific reason for remembering. Corroborative evidence becomes necessary in direct proportion to the uncertainty of the statements advanced. The surveyor should bear in mind that conflicting statements and contrary views of interested parties to boundary disputes are potentially fruitful sources of information concerning the original position of a corner.

To be reliable, testimony will indicate some knowledge of the position of the original monument. Landowners' opinions of their boundaries may be based upon their understanding of common law principles of boundaries determined by occupation alone. Such testimony does not provide direct evidence of the position of an obliterated corner. In no case should such opinions or long term belief thereon be deferred to in the absence of some reliance and tie to the original survey. Occupation and long use do not act to deprive the United States of title to land.

**6-21.** The following information should be included when obtaining testimony or data from an individual concerning the true point for an original corner or related information:

- (1) Name, age, address;
- (2) How long at that address;
- (3) When knowledge of the corner position first acquired;
- (4) A photograph including the corner point and the witness, with the date, photographer's signature, and the witness' signature; and
- (5) An actual statement by the witness, which is complete and signed.

**6-22.** The surveyor will show in the field notes, or in the report of a field examination, the weight given this testimony in determining the true point for an original corner (see section 9-29). The following points will serve as a guide:

- (1) The witness (or record evidence) should be duly qualified. The knowledge or information should be firsthand or, if hearsay, that fact noted; it should be complete; it should not be merely personal opinion. Hearsay statements will be documented, can be accepted, and generally assigned more weight if of a quality ordinarily accepted by cadastral surveyors.
- (2) The testimony (or record statement) should be such as can stand an appropriate test of its bona fide character.
- (3) The testimony (or the record) will be sufficiently accurate, within a reasonable limit, for what is required in normal surveying practice.

### Topographic Calls

**6-23.** The proper use of topographic calls of the original field notes may assist in recovering the locus of the original survey. Such evidence may merely disprove other questionable features or be a valuable guide in arriving at the immediate vicinity of a line or corner. At best a topographic call or calls can verify or disprove questionable evidence of the original monument or its accessories. In rare cases, they may serve as substantial evidence to fix the position of a point, line, or corner.

Allowance should be made for ordinary discrepancies in the calls relating to items of topography. Such evidence should be considered in the aggregate and when found to be corroborative, an average may be secured to control the final adjustment. This will be governed largely by the evidences nearest the particular corner in question, giving the greatest weight to those features that agree most closely with the record, and to such items as afford definite connection.

In comparing distances returned in the original field notes with those returned in the dependent resurveys, gross differences appear in a significant number of instances. In some cases the original surveyor apparently surveyed a line in one direction, but then reversed the direction in the record without making corresponding changes in distances to items of topography, or the

surveyor did not in fact survey in one direction but fabricated the topographic calls.

**6-24.** A careful analysis must be made by the surveyor before using topographic calls to fix an original corner point. Indiscriminate use will lead to problems and disputes where two or more interpretations are possible. Close attention will be given to the manner in which the original survey was made. Instructions for chaining in the earlier manuals indicate that memory was an important factor in recording distances to items of topography. Early field notes often appear to have shown distances only to the nearest chain or even a wider approximation. Often the feature will not afford a definitive connection and the distance can only be considered as an approximation within a range.

The weight to be given an item of topography noted in the field notes of an original survey, and shown upon the plat thereof, should be commensurate with the importance attached thereto in the execution of such original survey. It should be remembered that the position of items of topography in the interior of sections, as shown upon the plats of the public land surveys, has been almost invariably based upon estimates by the surveyor, rather than upon actual measurements thereto, and at best represents only an approximation of the actual position of the topography. It is ordinarily only the distances at which sections lines intersect various items of topography that are actually measured on the ground.

**6-25.** These facts have sometimes caused distrust and virtual avoidance of the use of topography in corner point verification or restoration where proper application might be extremely helpful. Misapplication usually may be avoided by applying the following tests:

- (1) The determination should result in a definite locus within a small area.
- (2) The evidence should not be susceptible of more than one reasonable interpretation.
- (3) The corner locus should not be contradicted by evidence of a higher class or by other topographic notes.

**6-26.** The determination of the original corner point from even fragmentary evidence of the original accessories, generally substantiated by the original topographic calls, is much stronger than determination from topographic calls alone. In questionable cases it is better practice, in the absence of other collateral

evidence, to turn to the suitable means of proportionate measurement.

### Witness Corners

**6-27.** A witness corner is not the corner point but a witness to the true point for the corner. The corner point being witnessed is recovered when the witness corner is recovered.

Ordinarily a witness corner established in the prior survey and not placed on a line of the survey will fix the true point for the corner at record bearing and distance, as does a bearing tree or bearing object.

Where the witness corner was placed on a line of the survey, if no complications arise, the witness corner will be used as control in determining the true point for the corner. If the factual statements in the field notes are clear as to interpretation, it is then merely a question of record bearing and distance from the witness corner to the true point for the corner. This presumes the section lines surveyed and marked in the field by the United States surveyors are in fact record bearings and distances between recovered corners. However, this is not usually the case. Therefore, in order to locate the true point for the corner, it will be necessary to adopt bearings and distances as ascertained from the corresponding section line.

For corners reestablished by double proportionate measurement, the true point for the corner will be determined by extending the line through the witness corner at record distance. For corners reestablished by single proportionate measurement, the true point for the corner will be determined by single proportionate measurement between the witness corner and the opposite controlling corner. Thus, in single proportionate measurement, the record bearing and distance is modified, and the witness corner becomes an angle point of the line.

Unfortunately, the factual statements of the original field notes are not always clear. In some surveys witness corners were called witness points. The record may indicate that the witness corner was established on a random line, or there may be an apparent error of calculation for distance along the true line. The monument may not have been marked "WC" plainly or at all. In these instances, or where there is extensive obliteration, multiple witness corners to one corner, or distortion or blunder in the measurement in the original record, each corner will be treated individually. The

important consideration is to locate the true corner point in its original position and document any exceptional situation.

The recovered on-line witness corner is properly used as a control point in the reestablishment of lost corners by the appropriate method of proportionate measurement. Typically, acreage is not returned to the witness corner position but to the true point for the corner. The on-line witness corner is used for section alinement and as a control point in the establishment of minor subdivision corners. The position of a recovered witness corner is, therefore, perpetuated.

Since the true point for the corner will usually be of major importance, the surveyor will proceed directly to its determination by the applicable methods if the witness corner is lost. If it is then impracticable to monument or mark the true point for the corner, a new witness corner will be established and marked as directed in chapter IV. The point for an on-line lost witness corner should be called for in the field notes but not monumented (section 4-16).

For treatment of "*Half-Mile Posts*," *Alabama and Florida*, see Chapter VII Notes.

### Line Trees

**6-28.** Under the law, a definitely identified line tree with distinguishable marks (see section 3-220) is a monument of the original survey. It properly is used as a control point in the reestablishment of lost corners by the appropriate method of proportionate measurement and treated just as is a recovered corner. It is monumented or referenced and becomes an angle point of the line. Typically, acreage is not returned to the line tree position on the plat. The line tree is used for section alinement and as a control point in the establishment of minor subdivision corners.

A problem arises where line trees, sometimes called sight trees or station trees, were improperly established on a random line and so recorded in the field notes rather than on the true line. Such line trees are generally of most value as guides in locating the original corners and as control points where there has been extensive obliteration of the corners themselves. The making of proportionate offsets from line trees on the random line to determine angle points of the true line lends the trees more influence than is warranted. In adopting such a scheme the surveyor would be assuming that if the original surveyor had followed the survey of the random



line with a survey of the true line he would have created angles at the same points as on the random line. The fact is that there might well have been angles in the true line, but they would be wherever the line struck trees on the true line—not at the same distances at all. The most probable location of the true line is on a straight line between the corners, if these corners are recovered, as reported in the record subsequent to the field notes of the random line.

Line trees not recovered will not be reestablished. In cases where not every line tree of record was recovered, a general statement may be made in the field notes that all original line trees along the lines returned were searched for but only the recovered line trees are reported. The point for a lost line tree, if needed, is determined by single proportionate measurement.

### Witness Points

**6-29.** A witness point is a monumented station on the line of a survey employed to perpetuate an important location without special relationship to any regular corner, except that the distance is known. It is a point of the original survey. It is treated just as is a recovered corner. By rule, a witness point is an artificial line tree. It is monumented or referenced, and becomes an angle point of the line. It properly is used as a control point in the reestablishment of lost corners by the appropriate method of proportionate measurement. Typically, acreage is not returned to the witness point on the plat. The witness point is used for section alinement and as a control point in the establishment of minor subdivision corners. The position of a recovered witness point is perpetuated. The point for a lost witness point is determined by single proportionate measurement and is called for in the field notes but may not be monumented (see section 4-18).

### Meander Corners

**6-30.** Although considered an intermediate monument, it is actually a corner of first order. The actual boundary of the meandered body of water is the ordinary high water mark or the line of mean high tide. Meander corners are set to delineate acreage, not to mark the boundary with the water body. Legal subdivisions of sections are created and areas are returned against the meander corners.

When recovered, meander corners normally control both alinement and proportionate measurement along the line, as any corner of first order. Meander corners

not recovered will normally be reestablished (see section 7-37). Resurvey and retracement records must be examined carefully because meander corners, by instructions, have been used differently for restorations and establishments.

### State Boundary Monuments

**6-31.** The BLM has no general authority to survey or resurvey State boundaries. However, the BLM does have general authority to survey or resurvey Federal interest lands that are adjacent to or abut State boundaries. The retracement and resurvey of State boundaries are authorized to the extent necessary to provide control for the survey or resurvey of the adjacent lands for the identification of the Federal interest lands. This includes the reestablishment and remonumentation of mile posts on State boundaries and the establishment and monumentation of corners of minimum control along State boundaries. The corners of township, range, section, and subdivision-of-section lines that intersect State boundaries are established as corners of minimum control.

The resurvey of a State boundary may be made under direction of the Supreme Court or may be authorized by the States involved with the consent of Congress. In connection with the survey or resurvey of adjacent Federal interest lands, it is proper to retrace as much of the State boundary as may be needed for a suitable closing. Identified original State boundary corners may properly be remonumented and corners of minimum control may be established and monumented. Lost corners should not be remonumented unless this is specifically sanctioned by appropriate authority. The original survey of certain State boundaries was executed under the former General Land Office (GLO) when specifically authorized by act of Congress.

**6-32.** Prior to any survey of a State boundary, the affected State governments will be notified. In addition and prior to any retracement or resurvey of a State boundary, a study of the history of the boundary should disclose whether:

- (1) The State boundary was surveyed prior to the public land survey system and the latter closed upon the boundary;
- (2) The public land survey system was surveyed prior to the State boundary line survey; or
- (3) An existing public land survey system line was adopted as the State boundary and mile posts were subsequently established.



Each requires its unique solution, which will be presented in the special instructions.

### International Boundary Monuments

**6-33.** The BLM has no general authority to survey or resurvey international boundaries. Prior to survey of Federal interest lands adjacent to or abutting an international boundary, the Department of State will be consulted and, particularly, the International Boundary Commission for the boundary with Canada or the International Boundary and Water Commission for the boundary with Mexico. Coordination will be established with governing authorities prior to approaching or surveying the international boundary.

### Significance of Official Action

**6-34.** The GLO and BLM instructions and policies for proper usage of the monuments of the original survey have varied when used to (1) to control section alignment, (2) to control reestablishment of lost corners, establishment of minor subdivision corners or subdivision of sections, or (3) to determine the true point for the corner using witness corners and “half-mile posts” (section 7-36). Such changes in technical policies are prospective in application and generally are not applied retrospectively. It has long been held by competent authority that official resurveys and retracements, after acceptance and official filing, are presumed to be correct, surveyed consistent with the laws and policies in effect at that time, and shall not be disturbed except upon proof by a preponderance of the evidence that they are fraudulent or grossly erroneous.

## Collateral Evidence of Obliterated Corners

### Good Faith Locations

**6-35.** It may be held generally that the claimant, entryman, or owner of lands has located his or her lands by the good faith location rule if such care was used in determining the boundaries as might be expected by the exercise of ordinary intelligence under existing conditions. A good faith location is a satisfactory location of a claim or of a local point. It is one in which it is evident that the claimant’s interpretation of the record of the original survey as related to the nearest corners existing at the time the lands were located is indicative of such a degree of care and diligence upon their part, or that of

their surveyor, in the ascertainment of their boundaries as might be expected for that time and place. This is referred to as the good faith location rule.

**6-36.** The relationship of the lands to the nearest corners existing at the time the lands were located is often defined by fencing, culture, or other improvements. In many parts of the country, county and other local survey monuments, which may consist of pipes or stones commonly used at the time, may be found at the apparent corners of the entryman’s improvements including fencing. The possible existence of such local monuments demands a diligent search for any records from the old local survey, but even if the monuments are of unknown origin they must be analyzed for good faith location. Lack of good faith is not necessarily chargeable if the entryman has not located himself according to a rigid application of the rules laid down for the restoration of lost corners where:

- (1) complicated conditions involve a double set of corners, both of which may be regarded as authentic;
- (2) there are no existing corners in one or more directions for an excessive distance;
- (3) existing marks are improperly related to an extraordinary degree; or
- (4) all evidences of the original survey or prior resurvey that have been adopted by the entryman as a basis for his or her location have been lost before the resurvey is undertaken.

Furthermore, the extent of recognition given by neighboring claimants to a local point used for the control of the location of claims very often carries with it the necessity for a consideration of its influence in the matter of the acceptability of such locations under the good faith location rule.

**6-37.** The surveyor should neither rigidly apply the rules for restoration of lost corners or the rules for subdivision of sections without regard to effect on location of improvements nor accept the position of improvements without question regardless of their relation or irrelation to existing evidence of the original survey and the description contained in the entry. Between these extremes will be found the basis for the determination of whether improved lands have been located in good faith. No definite specific set of rules can be laid down in advance. The solution to the problem must be found

on the ground by the surveyor. The responsibility to resolve the question of good faith as to location rests primarily upon the surveyor's judgment.

**6-38.** The question is whether the position of the lands claimed, occupied or improved is to be adopted under the good faith location rule, and whether, if so adopted, the claims thus acceptably located can all be properly protected by the dependent plan of resurvey. If the position of any claim fails to qualify under the good faith location rule it should be disregarded as to the effect produced thereon by the plan of dependent resurvey. On the other hand, if these claims are held to be acceptably located under the same rule, they should be adopted as the determining factor in the position of the lost corner or corners, or establishment of new corners; and if the claims are in such concordant relation to each other and to the identified evidence of the original survey as to receive full protection by the dependent plan of resurvey, the surveyor will proceed with full assurance of the adequacy of the plan. Otherwise, the question of other processes analogous to those of an independent resurvey or to the correction of conveyance documents or the Quiet Title Act should be considered.

If two or more claims are acceptably located, but are discordantly related to each other to a considerable degree (by virtue of irregularities in the original survey), it will be clear that the general plan of dependent resurvey may not afford protection to such claims. In this case, as before stated, some other process must be adopted to protect the acceptably located claims.

**6-39.** In cases involving extensive obliteration at the date of entry or selection, the entryman or their successors in interest should understand that the boundaries of the claim will probably be subject to adjustment in the event of a dependent resurvey. A general control applied to the boundaries of groups of claims will be favored as far as possible in the interest of justice, of equal fairness to all and of simplicity of resurvey. A claim cannot generally be regarded as having been located in good faith if no attempts have been made to relate it in some manner to the original survey.

**6-40.** Cases will arise where lands have been occupied in good faith, but whose boundaries as occupied disagree with the position of the legal subdivision called for in the description. A landowner's bona fide belief concerning the boundary location is not the same as a bona fide right within the meaning of 43 U.S.C. 772. A bona fide right within the meaning of 43 U.S.C. 772 is based on good faith reliance on evidence of the original

survey. Obviously, under these facts the rule of good faith as to location cannot apply. This is not a survey issue but a title issue and relief must be sought through the process of amended entry, correction of conveyance document under 43 U.S.C. 1746, quiet title action, tentative approval relinquishment, or interim conveyance reconveyance or relinquishment to cover the legal subdivisions actually earned, rather than through an alteration of the position of established lines. This is a process of adjudication rather than one of resurvey. A case of this character should be regarded as erroneous location in precisely the same manner as if the question of resurvey were not involved. The amendment of entries is a matter for adjudication by the BLM after the resurvey has been accepted and the plats officially filed.

### Satisfactory Local Conditions

**6-41.** It is not intended to disturb satisfactory local conditions with respect to roads, fences, and other evidence of use or occupancy. The surveyor has no authority to change a property right that has been acquired legally, nor accept the location of roads, fences and other use or occupancy as prima facie evidence of the original survey. Something is needed in support of these locations. This will come from whatever intervening record there may be, the testimony of individuals who may be acquainted with the facts, and the coupling of these things to the original survey.

In many cases due care has been exercised to place the property fences and other evidence of use or occupancy on the lines of legal subdivision and locate the public roads on the section or subdivision-of-section lines. These are matters of particular interest to the adjoining owners, and it is a reasonable presumption that care and good faith would be exercised with regard to the evidence of the original survey in existence at the time. Obviously, the burden of proof to the contrary must be borne by the party claiming differently. In many cases there are subsurface marks in roadways, such as deposits of a marked stone or other durable material, that are important evidence of the exact position of a corner if the proof can be verified. Also, knowledge regarding the construction of a purported property line fence, or other use or occupancy line can be obtained from long time landowners and community members and could provide positive evidence as to location in conformity with the good faith location rule.

**6-42.** A property corner or a use or occupancy position should exercise a regular control upon the retracement only when it was placed with due regard to the location

of the original survey, or agreement is so close as to constitute the best available evidence.

**6-43.** Other factors to be considered are the rules of the State law and the State court decisions, as distinguished from the rules laid down by the BLM (the latter applicable to the public land surveys created boundaries in all cases). Under State law in matters of agreement between owners, acquiescence, or adverse possession, property boundaries may be defined by roads, fences, use or occupancy lines, or survey marks, disregarding exact conformation with the original legal subdivision lines. These may limit the rights between adjoining owners, but generally have no effect on the boundaries of Federal interest lands.

**6-44.** In cases where the Federal Government has acquired land with a boundary created when the United States owned neither side of the boundary, the boundary may be defined by State law. For these boundaries, rights may have vested to a location disregarding exact conformation to the title lines or original legal subdivisions prior to the title being acquired by the Federal Government. The surveyor shall not impair such rights. The conflicting title lines and ownership lines are surveyed and monumented and the conflict area is returned upon the plat. Each intersection of conflicting boundaries is determined upon the ground and recorded in the field notes. The returns must describe and show the limits of the Federal ownership and the limits of the Federal title. The survey record will document the findings of fact, source of law (section 1-7), and conclusion at law supporting the determination. These cases require close collaboration with legal counsel and BLM Lands Staff.

### Local Points of Control

**6-45.** Once a local point of control is accepted in an official survey it has all the authority and significance of an original corner. The influence of such points is combined with that of the previously identified original corners in making final adjustments of the temporary points.

The acceptance of duly qualified and locally recognized points of control should verify the public land surveys, simplify resurveys, and avoid conflicting lines that differ only slightly in location. In this manner flexibility will be introduced in the plan of the dependent resurvey, at least to the extent of protecting satisfactory local actions in reliance on evidence of the original survey.

**6-46.** The surveyor cannot abandon the record of the original survey in favor of an indiscriminate adoption

of points not reconcilable with it. However, many situations will arise where locally accepted lines are in substantial agreement with evidence of the original survey, although without testimony or record evidence relating to the original survey. Where this circumstance is found, it is often better to accept a position based upon local interpretation rather than to disturb satisfactory existing conditions. The surveyor will endeavor to avoid disturbing the position of locally recognized lines when such action may adversely affect improvements, again, provided that there is substantial agreement with the evidence of the original survey. At the same time the surveyor must use extreme caution in adopting local points of control. These may range from authentic perpetuations of original corners down to marks that were never intended to be more than approximations. The surveyor must consider all these factors.

Chief among this class of evidence forming the basis of recognized positions of land boundaries are; recorded monuments established by local surveyors and duly agreed upon by interested property owners; the position of boundary fences determined in the same manner; and the lines of public roads, drainage or irrigation ditches, and timber cutting lines; when intended to be located with reference to the original subdivisional lines. The local record in these cases, when available, may furnish evidence of the original survey. If a point qualifies for acceptance, having satisfied the requirement for substantial agreement with evidence of the original survey, the presumption is strong that its position bears satisfactory relation to the original survey and the burden of proof to the contrary must be borne by the party claiming differently. Points that so qualify must be accepted as the best available evidence of the true position of the original survey.

**6-47.** It is not to be assumed, however, that because a large number or all of the claims are consistently related among themselves to an arbitrary system of control, which is itself altogether unrelated to the original survey, that such system is necessarily to be adopted as the basis of a dependent resurvey.

**6-48.** The age, position, and degree to which a local corner has been relied on by all affected landowners may lead to its adoption as the best remaining evidence of the position of the original corner. When a local reestablishment of a lost corner or a local establishment of a legal subdivision corner has been made by proper methods without gross error, it will ordinarily be acceptable. Monuments of unknown origin must be judged on their own merits, but these monuments should never be rejected out of hand without careful study.

It is a recognized principle that the restoration of a corner may be influenced by the position of one or more existing claims. This principle warrants, within suitable limits, the acceptance of a local determination that does not exactly coincide with a rigid application of the rules for restoration of lost corners and subdivision of sections.

Thus where locations are found to have been established on good faith reliance on evidence of the original survey the position of which cannot otherwise be fully demonstrated by existing evidence of the original survey, the theoretical point determined by the primary control will be set aside in favor of a near-by duly qualified corresponding point, the position of which has been agreed upon by the adjoining property owners. Such a point will then be recognized as the best available evidence of the true position for the corner.

**6-49.** The field note record of the dependent resurvey must clearly set forth the reasons for the acceptance of a local point not identified by actual marks of the original survey, but by nonofficial determinations. Recognized and acceptable local marks will be preserved and described. Monuments must be fully described in the field notes and a full complement of the required accessories recorded, but without disturbing or re-marking the existing monument. New monuments are established if required for permanence or to provide unique marks to clearly identify the corner. The evidence of the local marks will not be destroyed, and if disturbed, the final disposition will be fully described in the field notes. When a local point is not accepted, the field note record of the resurvey must also clearly set forth the reasons.

## Corner Positions Based on the Protection of Bona Fide Rights: 43 U.S.C. 772

**6-50.** The following sections describe the conditions that warrant the protection of bona fide rights as to location due to:

- (1) gross errors in the original survey;
- (2) inadequate original evidence such that the application of the normal methods for restoration of lost corners will impair bona fide rights; or
- (3) complicated conditions involving a double set of corners, both of which may be regarded

as authentic, which result (a) in irreconcilable conflicting evidence of the original corner positions, or (b) in conflicting positions when used for restoration of lost corners or subdivision of sections.

**6-51.** Bona fide rights as to location may vest to an official resurvey. This is in keeping with the principle of protecting bona fide rights based on an original survey, pursuant to 43 U.S.C. 772. As the Court said in *United States v. Reimann*, 504 F.2d 135, 139-140 (10<sup>th</sup> Cir. 1974):

It would be inequitable to permit the government . . . to accept a survey[,] . . . recording it with knowledge that it would be relied upon by patentees, and then grant the government the right to later correct its error, ex parte, to the detriment of those who did in fact, and in good faith, rely upon it.

**6-52.** An official resurvey shall not be overturned except upon clear proof of fraud or gross error amounting to fraud. This is especially true after a long lapse of time or good faith reliance. In some instances, to protect bona fide rights, the BLM has departed from a rigid application of dependent resurvey principles to ensure that long-accepted official survey lines are not disturbed, property boundaries are stabilized, and title as to location is secured. *Salt Wells Live Stock Co.*, A-26367 (May 9, 1952).

**6-53.** Bona fide rights as to location may also vest to local surveys that rely on evidence of the original survey. County and other local corners cannot be considered official United States corners unless and until they are accepted by the BLM in an official survey.

**6-54.** Corners established in an administrative survey by BLM employees, by other Federal departments and agencies, or by or for an Indian tribe, unless subject to special enactment, cannot be considered official United States corners unless and until they are accepted by the authorized officer of the BLM. In the absence of official acceptance by the BLM, users rely on such corners at their own peril. *Longview Fibre Co.*, 135 IBLA 170, 185 (1996).

### Other Situations Involving Protection of Bona Fide Rights

**6-55.** In the execution of a dependent resurvey, there may arise cases where occupancy and valuable



non-Federal improvements have been placed onto lands under title to the United States based on reliance on evidence of a local survey that is so discordantly related to existing authentic evidence of the original survey that such local corners cannot qualify for adoption either as physical evidence of the original survey, as good faith reliance on evidence of the original survey, as demonstrating satisfactory local conditions, or as a local point of control. There is no legal authority to disregard the identified evidence of the original survey or to accept a fraudulent or grossly erroneous local corner position, in these cases.

No general title or survey remedy has been devised other than that of removal. Whether such trespass remedy method appears to be practicable or not, the surveyor will submit a detailed report of the conditions found. The report will recommend procedures suited to the particular case. The recommendations will be designed to protect the claimant's improvements and will not disturb those who have acquired legal rights through location consistent with the appropriate official survey. These cases are exceptional in any township where regular control has been developed by careful retracement and thorough search.

A metes-and-bounds survey of an erroneous location cannot have the effect of conveying title. No legal title to Federal interest land can be established by use or occupancy outside the subdivisions named in the entry, selection, or patent, except during the period when the land was alienated, as adverse possession does not run against land under title to the United States. Sooner or later, the claimant would find him or herself without a complete legal title to the lands upon which he or she had spent his or her labors. Removal of improvements or an appropriate conveyance document, when the occupancy and improvements do not conform to the lines and subdivisions of the original survey is the only safe course to remedy such title defects.

**6-56.** As official resurveys themselves grow in number, cases will arise where a patent issued under an original survey is located and valuable non-Federal improvements are made after the official resurvey, and the improvements were made under good faith reliance on the official resurvey's restoration of the original survey. Problems develop when evidence of the original survey corners is later discovered that differs materially in location from the official resurvey's restored corners. In some such instances, established non-Federal improvements will be found on lands under title to the United States. In such a case, the survey that controls

the conveyance document is the most recent officially filed survey before the valid entry, application, or selection that resulted in the issuance of the patent or other conveyance, not the subsequent resurvey. In such cases, however, questions may be raised of "good faith reliance" on an official resurvey and therefore of possible bona fide rights as to location, and the surveyor will seek specific instructions.

No general title or survey remedy has been devised other than that of removal of the non-Federal improvements, if the claimant can reasonably do so, or the issuance of an amended entry to describe the occupied legal subdivisions. Whether such trespass remedy methods appear practicable or not, the surveyor will submit a detailed report of the conditions found. The report will recommend procedures suited to the particular case. The recommendations will be designed to protect the claimant's improvements, if possible, and will not disturb those who have acquired actual legal or bona fide rights as to location through location consistent with the appropriate official (re)survey. These cases are exceptional in any township where regular control has been developed by careful retracement and thorough search.

It is difficult to particularize the exact nature of the relationship of bona fide rights as to location to an official resurvey that presents the original survey in a position in conflict with the actual location of the original survey. There must be some latitude for construction. As the Court said in *Knight v. United States Land Association*, 142 U.S. 161, 181 (1891):

It is obvious, it is common knowledge, that in the administration of such large and varied interests as are intrusted to the Land Department, matters not foreseen, equities not anticipated, and which are, therefore, not provided for by express statute, may sometimes arise, and, therefore, that the Secretary of the Interior is given that superintending and supervising power which will enable him, in the face of these unexpected contingencies, to do justice. *Williams v. United States*, 138 U.S. 514, 524 (1891).

A metes-and-bounds survey of an erroneous location cannot have the effect of conveying title. Equitable title to Federal interest land may be established by substantial and long term improvements outside of the subdivisions named in the entry, selection, or patent, when based on good faith reliance on evidence of an official resurvey. However, sooner or later, the claimant would find him or herself without a complete legal title to the lands upon



which he or she had spent his or her labors. Questions of title and ownership will be discussed with legal counsel and the appropriate agency official. Title remedies must be documented, monumented, and described in the official survey record.

**6-57.** Another case may arise in the execution of an official resurvey where Federal occupancy and valuable Federal improvements have been placed onto lands determined not to be under title to the United States based on good faith reliance on evidence of a local survey or on an official resurvey that is so discordantly related to existing authentic evidence of the original survey that such corner positions cannot qualify for adoption in an official resurvey. The United States cannot claim the benefit of the bona fide right statutes, which were enacted to protect the owners of alienated lands located and occupied in good faith from interference by subsequent official resurveys.

The appropriate treatment of this case, where possible of application, consists in the removal of the Federal improvements from the occupied alienated legal subdivisions. However, when it is determined that the United States wishes to retain and clear title to the land, it may seek to purchase or condemn the property upon payment of just compensation. If the landowner acts first, the United States may be subject to a claim for inverse condemnation, in which case just compensation is also the measure of Federal liability. If sufficient time passes to satisfy State law, the Federal Government can obtain legal title to lands established by the occupancy and improvements of lands inside the subdivisions named in an entry, selection, or patent, as adverse possession does run for the United States. Ultimately, however, the Federal Government would have to act to clear legal title to the lands upon which it had made improvements, and the just compensation provision of the Constitution for a “taking” may still apply. Such cases will also be exceptional, however, in any township where regular control has been developed by careful retracement and thorough search.

Regardless of which course is ultimately chosen by Federal officials, the surveyor will submit a detailed report of the conditions found, with recommendations designed for protection of the Federal interest improvements and will not disturb those who have acquired legal or bona fide rights as to location through location consistent with the appropriate official (re)survey.

In any event, a metes-and-bounds survey of an erroneous location cannot have the effect of conveying title.

A written or directed conveyance to the United States, either through purchase, condemnation, or vested unwritten rights is the only safe course to remedy such title defects when Federal occupancy and improvements are found not to conform to the lines and subdivisions of the original survey or title lines.

### **Special Case Dependent Resurveys— Fictitious, Fraudulent, or Grossly Erroneous Surveys**

**6-58.** Special case conditions exist only in a township with use or occupancy lines or other improvements, and where the official record representing the original survey is fictitious, fraudulent, or grossly erroneous beyond any tolerable limit. The special case dependent resurvey is applicable when it has been determined:

- (1) not to identify the alienated lands by tract segregations;
- (2) there will be no projection of new subdivision lines; and
- (3) the original plat will not be cancelled.

**6-59.** Special case dependent resurveys provide methods adapted to areas with considerable amounts of alienated land or considerable amounts of Federal interest lands. Special case claim segregations are necessary only in those unusual cases where unrelated control prevents the reconstruction of sections and legal subdivisions by using existent corners and accepted local points of control that would adequately protect the alienated lands. It is applicable where the original survey cannot be identified with any degree of certainty in accordance with the representations of the approved plat and field notes, or where the prevailing conditions are such that strictly restorative processes, when applied as an inflexible rule between existing monuments or adopted local corner positions, are either inadequate or lead to unsatisfactory results. In effect this may employ the traces of the original survey, the good faith location rule or a combination of both in the same township. This type of dependent resurvey provides for the location of individual claims in conformance with the subdivisions of the resurvey.

These processes are found to be more flexible in their application than those of the strictly dependent type, but at the same time they are intended duly to protect all private rights that have been acquired upon the basis of the original survey and plat. The special case dependent

resurvey also perpetuates the record of the original survey with respect to the identification and description of the remaining Federal interest lands.

**6-60.** The special instructions will designate the sections containing alienated lands that will be dependently resurveyed. Where there is acceptable evidence of the original survey, the identification of the areas that have been disposed of must be the same as would ordinarily be derived by the regular subdivision of the section. The special case claims to be segregated by tract survey are those areas that (1) cannot be so identified, nor conformed satisfactorily, (2) where correction of conveyance document appears not to be an available remedy, and (3) where the disposals are found to be in conflict by overlap. Every corner of these claims common with Federal interest land within the survey group is to be monumented.

**6-61.** An abstract of pertinent records and a status diagram will be furnished to the surveyor showing lands whose boundaries cannot legally be disturbed. These include patented lands, valid entries or claims, school sections, land grants, tentative approvals, interim conveyances, disposals, reservations, or selections of lands whose position and description are based upon the original survey and plat subject to the dependent resurvey plan. The dependent resurvey will not be complete until each claim described by the special instructions has received full protection in the matter of location. Each must be protected by the assignment of subdivisions of the resurvey. In addition, the surveyor will be furnished with the status of all claims in the adjacent sections or of adjoining townships ungrouped for resurvey that might affect the dependent resurvey procedure. The abstract will be included with the other data to accompany the special instructions for the resurvey.

**6-62.** Before identifying alienated subdivisions, it is necessary to make certain the discrepancies are such that no adequate or satisfactory basis can be shown for the restoration of the former section-line boundaries as a whole. The plan of the special case dependent resurvey must be such that all lines, monuments, and plat representation will duplicate the description of all previous sections where disposals have been made. The alienated lands described by an official record now regarded as fictitious, fraudulent, or grossly erroneous beyond any tolerable limit must be reconstructed using the best available evidence of the original survey based upon good faith locations, rules for restoration of lost corners, and principles of section subdivision.

**6-63.** The jurisdiction of the BLM, the limit of the authority of the surveyor, and the bona fide rights of claimants, remain absolutely the same whether the resurvey of alienated lands is to be made upon the traces of the original survey, the good faith location rule or a combination. Thus, identified corners of the original survey in the immediate vicinity of alienated lands to be conformed or segregated are employed for the control of the location of such lands. The question of the good faith of the entryman is fully considered. Where the evidence of the original survey is so obliterated that lack of good faith in location cannot be charged against the entryman, whose claim boundaries may differ from a theoretical location determined by more rigid surveying rules and principles, the available collateral evidence is to be regarded as the best indication of the original position of the claim included in the original description. This available collateral evidence is employed as far as consistent for the control of the section boundaries and subdivisions within which such claim is located, and may become points of control for proportionate measurement purposes.

**6-64.** Where the surveyor cannot definitely locate a claim by identification of the original survey, the claimant should be asked to point out his or her boundaries. The boundaries of the alienated land, so determined, are fixed as between private and Federal interest lands, subject to official acceptance and filing of the resurvey. The surveyor should explain that an acceptably located claim must have a form agreeing with the original entry, approximately regular boundaries, an area not widely inconsistent with that shown on the original plat, and a location as nearly correct as may be expected from the existing evidence of the original survey.

**6-65.** Dispute may arise over adjustment of the line between adjoining and acceptably located entered, selected, approved, conveyed, alienated or patented lands. If the dispute cannot be reconciled by the surveying process, the claims are surveyed in conflict and so shown on the resurvey plat.

**6-66.** The surveyor cannot change materially the configuration of a special case claim as shown by its original description in order to indemnify the owner against deficiencies in area, to eliminate conflicts between entries, or for any other purpose. If improvements have been located in good faith, the special case claim resurvey should be so executed, or the conformation to the lines of the dependent resurvey so indicated, as to cover as nearly as possible these improvements and at the same time maintain substantially the form of the entry

as originally described. No departure from this rule is allowed.

**6-67.** An attempt should be made to consult an absentee owner so that the owner may point out the lands subject to a dependent resurvey. If the owner cannot be found and there is no indication of the boundaries of a claim, the surveyor should locate it from the nearest original point of control or from a point of a neighboring claim, or assign to the alienated lands the appropriate subdivisions of the resurvey. The controlling factors are individual and neighborhood improvements (such as buildings, wells, springs of water, cultivated lands, public roads, fences, corners of recognized local surveys, etc.) that, unless not made in good faith, indicate the evident intention of the claimant, entryman or patentee as to the position of his or her land. Those claim locations made in good faith must be recognized and accepted.

**6-68.** The following rules will be observed in executing the resurvey of designated special case claims:

(1) Each acceptably located claim that is at variance with the lines of the resurvey is surveyed and monumented at each angle point of the line.

(2) Where the limiting boundary of the resurvey has been reestablished in its original position, the portion of a special case claim lying outside the limiting boundary is not surveyed. The portion of the special case claim lying within the area of the resurvey has at least one identifiable original boundary. It should be defined by conformation to the lines of the dependent resurvey in a position that is properly related to the identified or restored corners on the limiting boundary.

(3) Where the boundaries of a special case claim are unacceptably located as pointed out by the claimant, the claim is surveyed and monumented in a suitable relation to the original survey. If the claimant protests the location, the surveyor will request that the protest be made in writing. The written protest should be submitted with the returns of the resurvey. Accurate ties will be made to the corners of the claim as unacceptably located. The surveyor will make a complete report of the facts with reference to the question of location. Further protection to the entryman may be sought by an amendment of entry or correction of conveyance document.

(4) Where the boundaries of a claim (or its conformation to the lines of the resurvey) do not cover the lands occupied, improved, or claimed, the claimant may express a desire to amend his or her entry or seek a correction of the selection or conveyance document. The fact should be stated in the field notes. A separate full report is made by the surveyor describing the subdivisions actually occupied and those sought under the amended entry or correction of selection or conveyance document that are not within the special case claim as surveyed, all looking to the protection of the title to the lands actually earned. Concurrently the current regulations relating to the amendment of entries, correction of conveyance documents, tentative approval relinquishments, interim conveyance reconveyances or relinquishments, or quiet title actions will be evaluated in coordination with BLM Lands Staff and with the Office of the Solicitor, where necessary.

(5) Where the regular quarter-quarter sections within a special case claim fall in approximately the same position as the regular quarter-quarter sections of the resurvey, the claimant, entryman, or patentee may desire to conform his or her claim to the resurvey. If no apparent objection is found by the surveyor, the desire by the claimant, entryman, or patentee to conform his or her claim to the resurvey will be documented as testimony and included in the official record. However, where a claim includes an irregular lot as originally described or where any part of a claim falls upon an irregular lot of the resurvey, the claim should be resurveyed as a whole, even though some or all of the lines of the claim may coincide with certain subdivisional lines of the resurvey.

No special case claim should be conformed to the lines of a resurvey under an involved amended or correction of conveyance document description that includes numerous subdivisions smaller than the regular quarter-quarter section, excepting as completely surveyed and monumented.

(6) Conflicting special case claims, each acceptably located, are surveyed and monumented and the conflict shown upon the resurvey plat. Each intersection of conflicting boundaries is determined upon the ground and recorded in the field notes. The number of acres

in conflict with each other will be shown in the field notes or plat, or both.

(7) Special case claims are designated by the appropriate aliquot part or lot number consistent with the controlling tentative approval, interim conveyance, claim, entry, or patent.

(8) Accessories are required with the monuments at the corners of the special claims as described in chapter IV.

(9) Where special case claim lines intersect, a connection is made to the nearest claim corner on each side of the intersection and recorded in the field notes of the section line. This is considered a satisfactory connection to all adjoining claims located within the special instructions. Where an extensive system of special case claims has been resurveyed, the interior claims of the block do not require connections.

(10) All recovered monuments of the original survey not otherwise reported upon are connected by course and distance with a corner of the resurvey. The connection and a description of the traces of the original corner as identified are recorded in the field notes of the resurvey. The old monument is marked AM (for amended monument), inverted and buried in place, if practicable, and the accessories are effaced unless the point may be needed to control the position of a claim.

## Independent Resurveys: Bona Fide Rights and the Location of Alienated Lands

**6-69.** In the conduct of a resurvey, there are certain factors that do not change, including the jurisdiction of the BLM as defined by the United States Congress, the limit of the authority of the surveyor, and the bona fide rights of claimants, where alienated lands are involved. These factors vary only slightly, whether the resurvey is of an official resurvey or of a local survey, and remain the same whether the resurvey is to be made upon the dependent or independent plan.

**6-70.** Areas that have been alienated must be the same as described by the patent or equivalent document of conveyance. Where there is either acceptable evidence

of the original survey or a good faith location based on the original survey, the identification of the areas will ordinarily be derived by the regular subdivision of the section. Areas to be segregated as tracts are those where:

(1) the prevailing conditions are such that strictly restorative processes, when applied as an inflexible rule between existing monuments will impair bona fide rights;

(2) adopted corner positions are either inadequate or lead to unsatisfactory results;

(3) it is determined for administrative purposes to supersede the record of the original survey with respect to the remaining Federal interest lands; or

(4) disposals are found to overlap. Every corner of these tracts will be marked by angle point monumentation.

**6-71.** Where the independent type of resurvey has been adopted as more feasible, identified corners of the original survey in the immediate vicinity of lands to be segregated are employed for the control of the location of such lands. The question of the good faith of the entryman is fully considered. Where the evidence of the original survey is so obliterated that lack of good faith in location cannot be charged against the entryman and whose claim boundaries may differ from a theoretical location determined by proportionate methods, the available collateral evidence is to be regarded as the best indication of the original position of the claim included in the original description. The collateral evidence is employed as far as consistent for the control of the section boundaries within which such claim is located.

**6-72.** Where the surveyor cannot definitely locate a claim by identification of the original survey, the claimant should be asked to point out his or her boundaries. The boundaries of the alienated land, so determined, are fixed as between private and Federal interest lands, subject to official acceptance and filing of the resurvey. The surveyor should explain that an acceptably located claim must have a form agreeing with the original entry, approximately regular boundaries, an area not widely inconsistent with that shown on the original plat, and a location as nearly correct as may be expected from the existing evidence of the original survey.

**6-73.** Dispute may arise over adjustment of the line between adjoining alienated tracts, each acceptably

located. If such disputes cannot be reconciled by the surveying process, the tracts are surveyed in conflict and so shown on the resurvey plat.

**6-74.** The surveyor cannot change materially the configuration of a tract as shown by its original description in order to indemnify the owner against deficiencies in area, to eliminate conflicts between entries, or for any other purpose. If improvements have been located in good faith, the tract survey will be so executed, or the conformation to the lines of the dependent resurvey so indicated, as to cover these improvements as nearly as possible, and at the same time the form of the entry as originally described is substantially maintained. No departure from this rule is allowed.

**6-75.** The amendment of entries, correction of conveyance documents, tentative approval relinquishments, or interim conveyance, reconveyance or relinquishments is a matter for adjudication by the BLM after the resurvey has been accepted and the plats filed in the land office.

**6-76.** An attempt should be made to consult an absentee owner so that he or she may point out the lands subject

to a tract survey. If the owner cannot be found and there is no indication of the boundaries of a claim, the surveyor should locate it from the nearest original point of control or from a point of a neighboring claim, or assign to the alienated lands the appropriate subdivisions of the independent resurvey. The controlling factors are individual and neighborhood improvements (such as buildings, wells, springs of water, cultivated lands, public roads, fences, corners of recognized local surveys, etc.) that, unless not made in good faith, indicate the evident intention of the claimant, entryman or patentee as to the position of his or her land. Those claim locations made in good faith must be recognized and accepted.

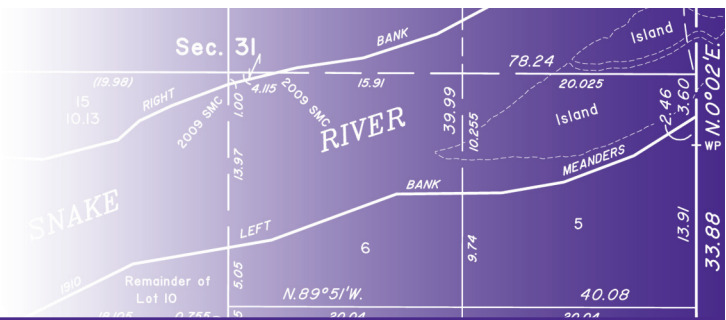
**6-77.** Each nonconformable valid claim in a township is given a serial tract number, commencing with No. 37 in the smallest numbered and entered section of the original plat, progressing through the township in the order in which lot and sections are numbered. A tract number is used but once in a township, and if any tract lies partly in two or more townships subject to resurvey, the number applied to the tract in the first township resurveyed is not used for other tracts in the adjoining township.





## Chapter VII

# Resurveys and Restoration



## Restoration of Lost Corners

**7-1.** When every means of identifying the original position of a corner has been exhausted, the surveyor will restore the lost corner by applying proportionate measurement, which harmonizes surveying practice with legal and equitable considerations involved in controversies concerning lost land boundaries.

**7-2.** A *lost corner* is one whose original position cannot be determined by substantial evidence, either from traces of the original marks or from acceptable evidence or reliable testimony that bears upon the original position, and whose location can be restored only by reference to one or more interdependent corners.

Thus, if substantial evidence of the position of the original corner exists, it is an existent or obliterated corner. This position shall be employed in preference to applying the rule that would be proper only in the case of a lost corner.

In addition, once a corner is considered lost, it is the surveyor's responsibility to assure that the restoration method and the restored position comply with the statutory protection of bona fide rights requirements delineated in 43 U.S.C. 772 and 773 and as described in this Manual.

**7-3.** Lost corners have been reestablished in official resurveys. These corners take on all the authority of an original corner except upon proof by a preponderance of the evidence that the resurvey was fraudulent or grossly erroneous. The surveyor must be aware that land may be conveyed or improvements made with reference to these reestablished corners.

**7-4.** The preliminary retracements show the discrepancies of courses and distances between the original record and the findings of the retracement. The restoration of the lost corners cannot proceed until the retracement of the original survey has been completed. The retracement is based upon the courses and distances of

the original survey record, initiated and closed upon known original corners.

**7-5.** Existing original corners shall not be disturbed. Consequently, discrepancies between the retracement measurements and the measurements shown in the record have no effect beyond the accepted corners. Generally, recovered line trees, witness corners, witness points, and other definitely identifiable original marks or regular corners established on the line and of record are original corners and part of the interdependent corners controlling the original survey. This restates the common law hierarchy of calls for monuments as controlling over calls for measurements. The differences in measurement are distributed proportionally within the several intervals along the line between the accepted corners.

The retracements will show various degrees of accuracy in the lengths of lines, where in every case it was intended to secure true horizontal distances. Prior to 1900 most of the lines were measured with the Gunter's link chain. Such a chain was difficult to keep at standard length, and inaccuracies often arose in measuring steep slopes by this method.

All discrepancies in measurement will be verified with the object of placing each difference where it properly belongs. Manifest blunders in measurement are removed from the general average difference and placed where the blunder was made. In cases where the proportioned position cannot be made to harmonize with all the calls of the original field notes, due to errors in description or to discrepancies in measurement made apparent by the retracement, it should be ascertained which of the calls are entitled to greater weight and which calls should be subordinate. The accumulated surplus or deficiency that remains is to be uniformly distributed by proportionate measurement.

**7-6.** Cases arise where the original survey record has been destroyed and the copies immediately available to the surveyor are transcribed copies of the duplicate

record. If field conditions do not match the transcribed duplicate record, the duplicate record will be compared to the transcribed copies to assure accuracy.

Transcribed copies of a different source are also found in county offices and other Federal offices when the only system to make copies of the official record was to copy them by hand. If field conditions do not match the transcribed copy record, the original record will be compared to the local transcribed copies to assure accuracy.

**7-7.** A proportionate measurement is one that gives equal relative weight to all parts of the line based upon a process conforming to the method followed in the original survey. The excess or deficiency between two existent corners is so distributed that the amount given to each interval bears the same proportion to the whole difference as the record length of the interval bears to the whole record distance. After the proportionate difference is added to or subtracted from the record length of each interval, the sum of the several parts will equal the new measurement of the whole distance.

Relative to proportionate measurement in order to harmonize the restorative process with the methods of the original survey, the principle of the precedence of one line over another of less original importance is recognized, thus limiting the control. The type of proportionate measurement to be used in the restorative process will depend on the method that was followed in the original survey. Standard parallels will be given precedence over other township exteriors, and ordinarily township exteriors will be given precedence over subdivisional lines; section corners will be relocated before the position of lost quarter-section corners can be determined.

## Primary Methods

### Double Proportionate Measurement

**7-8.** The term “double proportionate measurement” is applied to a new measurement made between four known corners, two each on intersecting meridional and latitudinal lines, for the purpose of relating the cardinal equivalents intersection to both.

In effect, by double proportionate measurement the record directions are disregarded, excepting only where there is some acceptable supplemental survey record, some physical evidence, or testimony that may be brought into the control. Corners to the north and south

control any latitudinal position. Corners to the east and west control the position in longitude. One identified original corner is balanced by the control of a corresponding original corner on the opposite side of a particular lost corner that is to be restored. Each identified corner is given a controlling weight inversely proportional to its distance from the lost corner. *Lengths of proportioned lines are comparable only when reduced to their cardinal equivalents* (section 7-9). The method may be referred to as a “four-way” proportion. The method of double proportionate measurement is generally applicable to the restoration of lost corners of four townships and of lost interior corners of four sections.

### Cardinal Equivalent

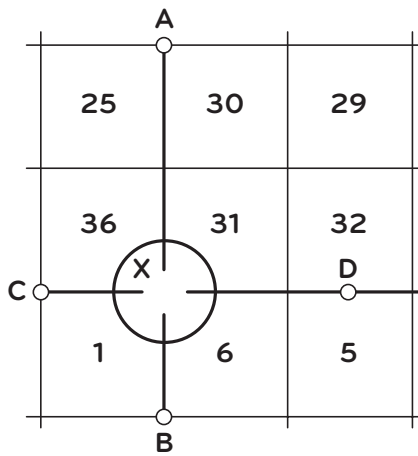
**7-9.** Use of cardinal equivalent employs only the northerly components (latitudes) of the north and south controlling record lines to compute the latitudinal position, and only the easterly components (departures) of the east and west controlling record lines to compute the longitudinal position. This is different from using distances of the controlling record lines in the computation of proportionate measurement.

Failure to determine the direction of each line with reference to the true meridian (cardinal) could produce erroneous results. Distortion encountered while using grid bearings on a coordinate system could introduce errors and thus incorrect results if factors of geodesy are not accounted for. In State plane coordinate systems, the grid scale factor varies across the project. Datum differences could introduce errors into the computations. Error can also be introduced if the lines are at dramatically different elevations, since the Public Land Survey System datum is based upon measurements at actual average ground elevation along the line.

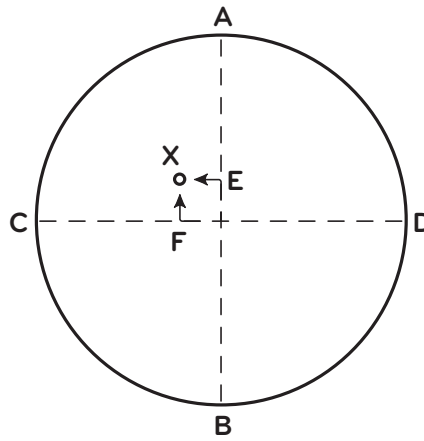
### Township Corners

**7-10.** In order to restore a lost corner common to four townships, a retracement must be made between the nearest known corners on the meridional line, north and south of the lost corner. The latitudinal position for the lost corner will be determined proportionately between those corners based on the comparative cardinal equivalents of the old and new surveys. In a similar fashion, the nearest corners on the latitudinal line will be connected. The position in departure (longitude) will be determined.

Figures 7-1 and 7-2 illustrate the plan of double proportionate measurement. Points A, B, C, and D represent



Lost township corner in vicinity of X.

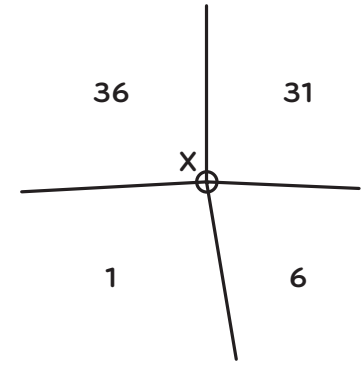


A, B, C, D—Control corners.

E—Proportionate point for X in latitude between A and B.

F—Proportionate point for X in departure between C and D.

The correct position of X is at the intersection of lines extended east or west from E and north or south from F.



Restored corner showing true direction of township lines.

Figure 7-1. The plan of double proportionate measurement.

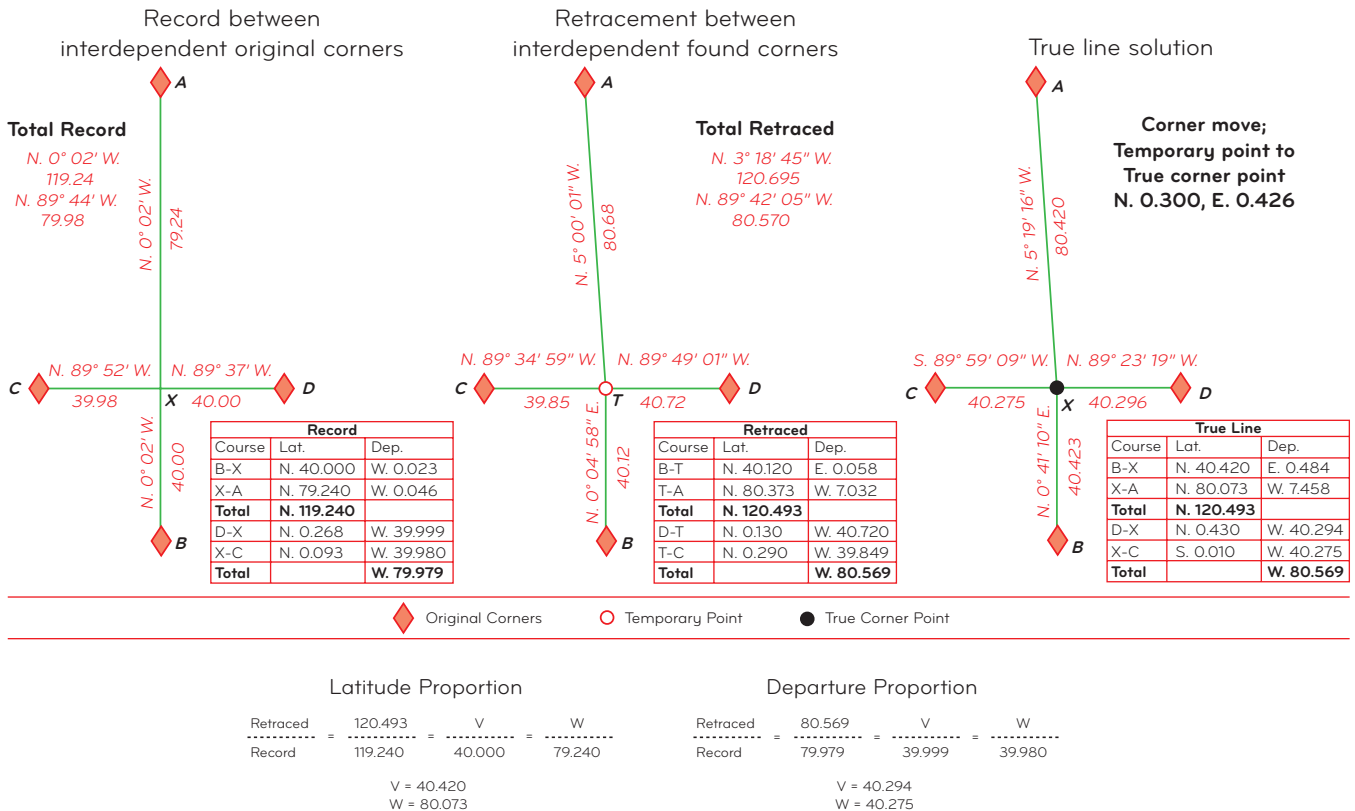


Figure 7-2. Double proportionate measurement and cardinal equivalents.

four original corners that will control the restoration of the lost corner X. On the large scale diagram the point E represents the proportional measurement in latitude between A and B, and similarly, the point F represents the proportional measurement in departure (longitude) between C and D. The point X satisfies the first control for latitude and the second control for departure by “double proportionate measurement.”

**7-11.** A lost township corner cannot safely be restored, nor the boundaries ascertained, without first considering the field notes of the four intersecting lines and examination of the four township plats. In most cases there is a fractional distance in the half-mile to the east of the township corner, and frequently in the half-mile to the south. The line to the west may have been retraced, and the measurement noted in the field notes. The line to the north is usually regular, with quarter-section and section corners at normal intervals of 40.00 and 80.00 chains, but there may be closing corners or retracement measurements on any or all of the boundaries so that it is important to verify all distances by reference to the field notes.

### *Section Corners*

**7-12.** Lost interior corners of four sections, where all the lines therefrom have been run, will also be reestablished by double proportionate measurement. The control for such restoration will not extend beyond the township boundary. If the controlling corner on the boundary is lost, that corner will be reestablished beforehand.

### *Three-Point Control*

**7-13.** Where the line has not been established in one direction from the lost township or section corner, “three-point control” should be used to reestablish the position of the corner. The record distance (reduced to its cardinal equivalent) to the nearest identified corner in the direction opposite from the missing line will be used, along with proportionate measurement between the other two corners.

Thus, in figure 7-1, if the latitudinal line in the direction of the point D has not been established, the position of the point F in departure would have been determined by reference to the record departure from the point C. The position of the point E in latitude would be determined by proportionate measurement between the points A and B.

### *Two-Point Control*

**7-14.** Where the intersecting lines have been established in only two of the directions, “two-point control” should be used to reestablish the position of the corner. The record distances, reduced to their cardinal equivalents, to the nearest identified corners on the intersecting lines will control the position of the corner. The record latitude on the meridional line will determine the latitudinal position and the record departure on the latitudinal line will determine the meridional position of the corner. What is intended by record distance is the measure established in the original survey.

### *Index Correction*

**7-15.** An index correction for systematic error in measurement should be made in applying the record measurements for two or three-point control (section 7-57) if it is obvious that a more harmonious relation to the representations of the approved plat or plats would be thus accomplished.

Experience and good judgment are required in applying an index correction. If the original survey was carelessly executed, no definite standard of length or direction of lines can be set up as representing that survey. On the other hand, the work may have been reasonably uniform within its own limits, yet inaccurate with respect to exact base standards. It is only a demonstrable and consistent excess or deficiency of the original work, determined within practical limits, that can justify the application of an index correction. If such consistency is not established the only rule that can be applied is that a record of 80.00 chains in distance means just that by exact standards, true horizontal measurement.

### *Single Proportionate Measurement*

**7-16.** The term “single proportionate measurement” is applied to a new measurement made on a line to determine one or more positions on that line.

By single proportionate measurement the position of two identified corners controls the direction of that line. The method is sometimes referred to as a “two-way” proportion, such as a north-and-south proportion or an east-and-west proportion. Examples are a quarter-section corner on the line between two section corners, all corners on standard parallels, and all corners occupying intermediate positions on a township boundary line.

**7-17.** In order to restore a lost corner on a line by single proportionate measurement, a retracement is made



connecting the nearest identified corners on the line. These corners control the position of the lost corner. The lost corner is then reestablished at proportionate distance on the line connecting the recovered corners. Proper adjustment is made on an east and west line to secure the latitudinal curve. Any number of intermediate lost corners may be located on the same plan.

### Standard Parallels

**7-18.** Restorations of lost corners of a standard parallel are controlled by the regular standard corners. These include the standard township, section, quarter-section, and sixteenth-section corners and meander corners. Also included are closing corners that were originally established by measurement along the standard line as points from which to start a survey and other corners that have been established by measurement in a retracement or dependent resurvey along the standard line.

Lost standard corners will be restored to their original positions on a base line, standard parallel, or correction line, by single proportionate measurement on the line connecting the nearest identified regular standard corners on opposite sides of the lost corner or corners.

**7-19.** Corners on base lines are regarded the same as those on standard parallels. The term “correction line” was used for what is now called the standard parallel. The corners first set in the running of a correction line are called standard corners. Those that were set afterwards at the intersection of a meridional line are called closing corners.

### Township Boundaries

**7-20.** All lost section and quarter-section corners on the township boundary lines will be restored by single proportionate measurement between the nearest identified corners on opposite sides of the lost corner, north and south on a meridional line, or east and west on a latitudinal line. An exception to this rule will be noted in the case of any exterior the record of which shows a deflection in alinement between the nearest identified corners on opposite sides of the lost corner (section 7-51). (For another exception see section 7-34.)

The control for either restoration should not extend beyond the township corner. If the controlling township corner is lost, that corner will be reestablished first.

**7-21.** Two sets of corners have been established on many township lines and on some section lines. Each

set applies only to sections on its respective side of the line. Which corners control the restoration of a lost corner will depend on how the line was surveyed. Three cases are discussed, senior–senior corners, junior–senior corners, and senior–senior corners—hiatus, overlap, or angle points.

### Senior–Senior Corners

**7-22.** Where both sets of corners have been established by measurement along the line in a single survey, and each corner controls equally for both measurement and alinement. All corners are corners of maximum control (figure 7-3).

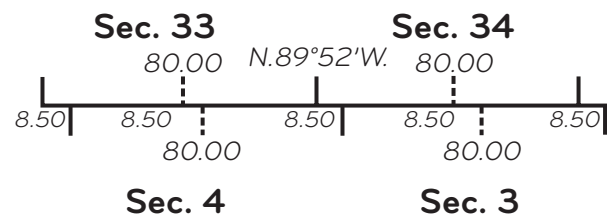


Figure 7-3. Two sets of corners established in a single survey.

### Junior–Senior Corners

**7-23.** This situation exists where one set of corners was established for one side of the line, and a second set of corners was established for the other side of the same line in the course of a later resurvey or retracement (figure 7-4).

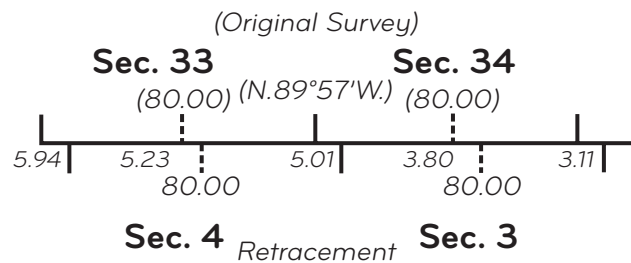


Figure 7-4.

The line is regarded as having been fixed in position by the senior survey and subsequent dependent resurveys or retracements. If both sets of corners are recovered, a junior survey, if it was established in the course of an obvious careful resurvey or retracement, reporting the most recent measurement of the line, will be used for alinement of the line and for control in restoring a lost senior corner of the line.

**7-24.** This procedure is not advisable where the junior corner was not established by an obvious careful

resurvey or retracement, evidenced by its recovery far off line. That condition can only be shown by retracing enough of the line to determine its bearing. Where there has been extensive loss of corners, particularly the senior corners, the existent junior corners may constitute the best available evidence of the line itself. In such a case the junior corners will exercise control for both measurement and alinement.

**7-25.** Restorations of lost corners on a junior-senior line are controlled by the regular corners. These include the corners that were originally established by measurement along the line and other corners that have been established in an obvious careful resurvey or retracement along the line.

A lost junior corner will be reestablished on the line by using single proportionate measurement between the nearest regular corners to the right and left of the lost corner. The position of a restored junior corner should be verified by a retracement of the line to the next original junior corner in each direction.

**7-26.** In some older surveys, the policy was to establish junior corners without a careful retracement of the senior line. In these cases, a recovered junior corner not actually located on the line that it was intended should not control the line for measurement or alinement. The new junior corner will be positioned in a cardinal direction, north or south on a latitudinal line, or, east or west on a meridional line, from the original junior corner onto the line intended. These new junior corners are established after a retracement of the line.

**7-27.** The new monument in those cases where it is required will always be placed on the senior line. An off-line monument in such cases should be marked AM (for amended monument), inverted and buried in place, if practicable, and will be connected by course and distance. The field notes of the resurvey must include a full description of the old monument as recovered and a clear statement that the new monument is set at the true corner point.

**7-28.** When a junior corner is recovered off the senior line and the new monument is established at the true corner point, the *original* position will control in the proportionate restoration of lost corners dependent upon the junior corner. The positioning of sixteenth-section corner(s) or lot corner(s) on the junior line, will be based on the measurement to the *original* position of the junior corner.

**7-29.** The correct position for the minor subdivision corners for sections on the side to which the junior corners refer are as protracted on the plat of those sections. When a monument is to be established at the protracted subdivision corner position, the *original* position of the section junior corners will control in the establishment. The proportionate measurement position between the *original* positions of the junior corners will be moved in a cardinal direction, north or south on a latitudinal line, or, east or west on a meridional line, to the true point on the line. This true corner point for the subdivision corner will control the location of the legal subdivisions for the section on the side to which the junior corners refer. These procedures may need to be modified if gross distortions in position or measurement are involved.

**7-30.** A junior corner established without a retracement of the senior line ordinarily is not used as a control corner in restoring a lost senior corner. However, where an obviously careful retracement of the senior line has been made and the field notes state clearly that new monuments were set on the line, the monuments become the best available evidence of the position of the senior line. In such a case the junior corners will exercise control for both measurement and alinement of the line to the same extent as closing corners (section 7-41).

**7-31.** A different problem is where the record tie from a junior corner to a corner of the senior line is fictitious, grossly in error, or in some way irreconcilable. If the junior corner in such a case is recovered, it should normally control the proportions along the junior line regardless of its disagreement with the record. If there is no evidence whatever of the junior corner, and ample proof that the retracement of the senior line was not made as called for in the field notes, the junior corner should not be restored without verifying the nearest authentic junior corners in each direction. The restoration should then be made by the method most nearly in harmony with the official plat(s). No general rule can be advanced. The procedure to be adopted will have official sanction prior to remonumentation.

#### ***Senior–Senior Corners— Hiatus, Overlap, or Angle Points***

**7-32.** On rare occasions the second surveyor patently established a completely separate line creating a hiatus or overlap. Each set of corners then control only its respective line. Where complications develop, the surveyor will report to his or her supervising office the

identity and correlation of corners or other evidence recovered before restoring the lost corners. Each such case should be considered individually (figure 7-5).

The same reporting instruction applies to lines on which the original corners have become angle points and may have three sets of corners.

**7-33.** Within the PLSS, when a gap exists between two official surveys, the land is unsurveyed, i.e., not identified by an official survey, and is public domain land subject to identification and description by survey (*United States v. Weyerhaeuser*, 392 F.2d 448 (9<sup>th</sup> Cir. 1967); *reh'g denied*). When a survey overlap or an entry/patent overlap exists, an examination must be made as to the official filing dates of the surveys, the applicable application, selection, or entry dates of alienated lands, and a full report made.

#### *Modified Single Proportionate Measurement*

**7-34.** An exception to the usual application of single proportionate measurement is occasionally important. There may be persuasive proof of a deflection in the alinement of the exterior, though the record shows the line to be straight. For example, measurements east and west across a range line, or north and south across a latitudinal township line, counting from a straight-line exterior adjustment, may show distances to the nearest identified subdivisional corners to be substantially long in one direction and correspondingly short in the opposite direction. This condition, when supported by substantial evidence, would warrant an exception to the straight-line or two-way adjustment because under the

rules for the acceptance of evidence, the evidence outweighs the record. The rules for a four-way or double proportionate measurement would then apply here.

#### *Section Boundaries*

**7-35.** All lost quarter-section corners on the section boundaries within the township will be restored by single proportionate measurement between the adjoining section corners, after the section corners have been identified or restored.

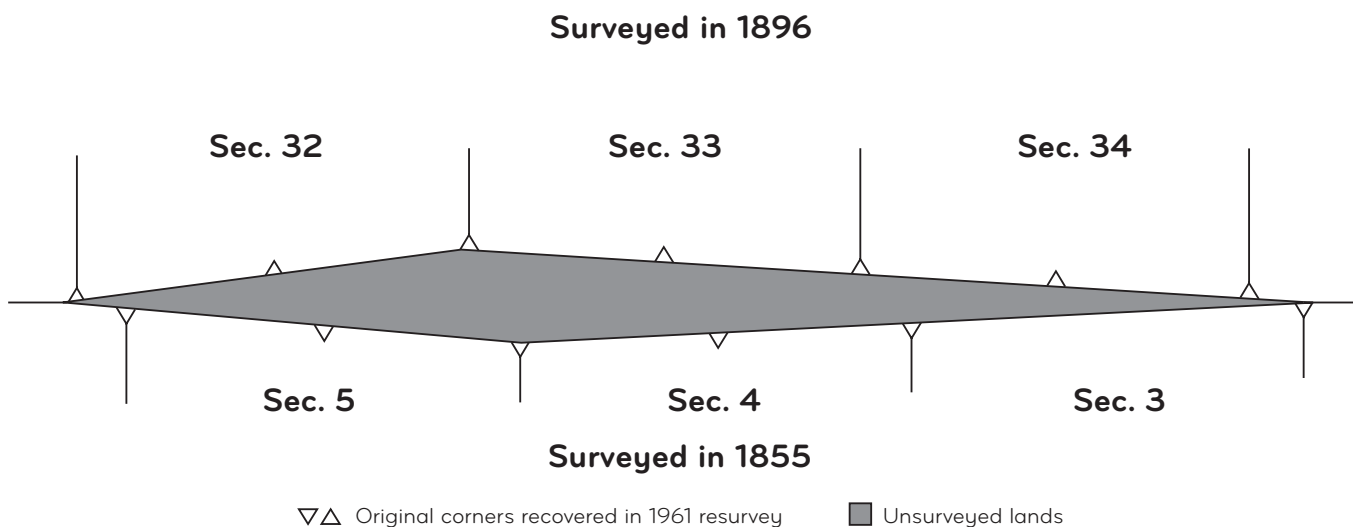
In those cases where connections from the lost quarter-section corner to other regular monuments of the line nearer than the section corners have been previously noted, these will ordinarily assume control in the restoration. Such monuments may include another quarter-section corner, minor subdivision corners, a meander corner, a witness corner, a witness point, an angle point, a closing corner, a junior corner, a corner of minimum control, a subdivision-of-section corner, a special survey corner, or a line tree, any of which may have been established when the line was previously surveyed or dependently resurveyed (section 7-41).

#### *“Half-Mile Posts,” Alabama and Florida*

**7-36.** See Chapter VII Notes for an explanation of “half-mile posts” and treatment of the evidence of location.

#### *Meander Corners*

**7-37.** Lost meander corners, originally established on a line projected across the meanderable body of water,



**Figure 7-5.** Two sets of corners established in sequential surveys creating two lines.

will usually be relocated by single proportionate measurement. In some older surveys, meander corners were surveyed from opposite directions and the intermediate portion across the meanderable body of water was completed by random and true line. Using this method some section lines were not established as straight lines. Lost meander corners, originally established by this method and not on a straight line, will usually be relocated by irregular boundary adjustment (section 7-51). However, in either case, the facts must be considered with regard to the specific problem in hand.

**7-38.** Under favorable conditions a lost meander corner may be restored by treating the shore line as an identified natural feature. In the event of extensive obliteration of the original corners within the locality this position may be preferable to one obtained by proportionate measurement carried from a considerable distance.

**7-39.** In extreme cases, restoration by adjustment of the record meander courses to the bank or shore line may be indispensable to the reconstruction of the section boundaries, especially where there is extensive obliteration, where there has been obvious stability to the bank or shore line, or absence of appreciable changes by erosion or accretion, the record meander courses and distances may be adjusted or conformed to the salients and angles of the physical bank or shore line. This may give a location in both latitude and departure, in latitude only, or in departure only.

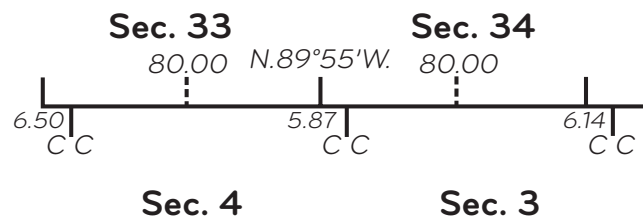
**7-40.** Occasionally, it can be demonstrated that the meander corners on opposite banks of a wide river were actually established as terminal meander corners even though the record indicates the line was projected across the river. If the evidence conclusively outweighs the record, a lost meander corner in such a case should be relocated by one-point control. Furthermore, if in such cases good faith occupation has followed protracted subdivision-of-section lines, the portions of the section on each side of the river having been treated as independent fractional sections, a corresponding plan of subdivision is proper (section 7-56).

### Closing Corners

**7-41.** A lost closing corner will be reestablished on the true line that was closed upon, and at the proper proportional interval between the nearest regular corners to the right and left. Restorations of lost closing corners are controlled by the regular corners. These include the corners that were originally established by measurement along the line and other corners that have been

established in an obvious careful resurvey or retracement along the line.

**7-42.** Where a single set of corners was established in the survey of a line and closing corners were subsequently established at intersection of section lines on one side, the corners first established generally will control both the alinement and the proportional measurement along the line. The original quarter-section corners nearly always referred to sections on only one side of the line after the closing corners were established from the other side (figure 7-6).



**Figure 7-6.** A single set of corners established the line and subsequent corners were established at intersections.

**7-43.** Where there has been extensive loss of corners, and particularly of the senior corners, the existent or obliterated closing corners may constitute the best available evidence of the line itself. In such a case they should exercise control for both measurement and alinement.

**7-44.** A lost closing corner on a standard parallel or other controlling boundary will be reestablished on the true line that is closed upon by using single proportionate measurement between the nearest regular corners to the right and left of the lost corner. The position of a restored closing corner should be verified by a retracement of the line for which it was designed to mark its terminus.

**7-45.** In older surveys the usual policy was to establish closing corners without a retracement of the line closed upon. The corners were established with a tie in one direction only and set at record bearing. In these cases, a recovered closing corner not actually located on the line that was closed upon will determine the direction of the closing line, but not its legal terminus. The correct position is at the true point of intersection of the two lines. Closing corners and other corners at an intersection of two lines or at the termination of one line on another are established after a retracement of the line closed upon.

The new monument in those cases where it is required will be placed at the true point of intersection. An

off-line monument in such cases should be marked AM (for amended monument), inverted and buried in place, if practicable, and will be connected by course and distance. The field notes of the closing line must include a full description of the old monument as recovered and a clear statement that the new monument is set at the true point of intersection.

When an original closing corner is recovered off the line closed upon and the new monument is established at the true point of intersection, the *original* position will control in the proportionate restoration of lost corners dependent upon the closing corner. In a like manner the positioning of sixteenth-section corner(s) or lot corner(s) on the closing line, between the quarter-section corner and the closing corner, will be based on the measurement to the *original* position of the closing corner.

**7-46.** The quarter-section corners for sections on the side to which the closing corners refer were often not established in older surveys. The correct positions are as protracted on the plat of those sections. When a new monument is to be established at the protracted quarter-section position, the *original* position of the section closing corners will control in the establishment. The proportionate measurement position between the *original* positions of the section closing corners will be moved in a cardinal direction, north or south on a latitudinal line, or, east or west on a meridional line, to the true point on the line. This true point for the quarter-section corner will control the location of the legal subdivisions for the section on the side to which the closing corners refer. These procedures may need to be modified if gross distortions in position or measurement are involved.

**7-47.** A closing corner established without a retracement of the line closed upon ordinarily is not used as a control corner in restoring a lost corner of the line closed upon. However, where an obviously careful retracement of a line has been made and the field notes state clearly that new monuments were set at the true points of intersection, the monuments become the best available evidence of the position of the line. In such a case the closing corners will exercise control for both measurement and alinement of the line to the same extent as corners of a junior survey (section 7-23).

**7-48.** Closing corners in some cases have been established where a line of the survey crosses previously surveyed claim lines (section 3-74). These corners are established after a retracement of the line intersected and monumented when administratively required. In the

past, these corners have been termed “crossing closing corners.”

If an obviously careful retracement of the two intersecting lines has been made, and the field notes state clearly that a monument (corner of minimum control, closing corner, crossing closing corner, or point of intersection) was set at the true point of intersection, the monumented corner is the best available evidence of the position of both lines. As such, the monumented corner will exercise control for both measurement and alinement of both lines. If a retracement of the intersected line indicates a closing corner purportedly set at the true point of intersection is substantially off that line, it will be moved to the intersection position and the existing monument will be dealt with as described in section 7-45.

**7-49.** A different problem occurs where the record tie from a closing corner to a corner of the line closed upon is fictitious, grossly in error, or in some way irreconcilable. If the closing corner in such a case is recovered, the closing corner will normally control the direction of the closing line regardless of its disagreement with the record. If there is no evidence whatever of the closing corner, and ample proof that the closing was not made as called for in the field notes, the closing corner should not be restored without verifying the nearest authentic closing on each side of the line closed upon and the nearest authentic corner on the closing line. The restoration should then be made by the method most nearly in harmony with the official plat(s). No general rule can be advanced. The procedure to be adopted will have official sanction prior to remonumentation of the lines.

## Secondary Methods

**7-50.** The foregoing are the general rules for the restoration of lost corners applicable under general and normal conditions, where the principal problem has to do with the disappearance of monuments resulting from natural causes or from disturbances due to the clearing, cultivation, and other uses of the land. The special cases that are hereinafter cited under secondary methods with respect to broken boundary lines and limited control are not applicable excepting under those conditions where the primary methods of proportionate measurement cannot be applied.

The preceding instructions will be applicable in the large majority of cases. If there seems to be some difficulty or inconsistent result, a careful check will be made of the record data. The special instructions



for the original survey, the plat representation on the original, duplicate, and triplicate copies, or some call of the field notes on the original and duplicate copies, or descriptive notes, may clarify the problem. This research becomes very important in the more difficult problems involved with the recovery of an old line or boundary.

### Irregular Boundary Adjustment

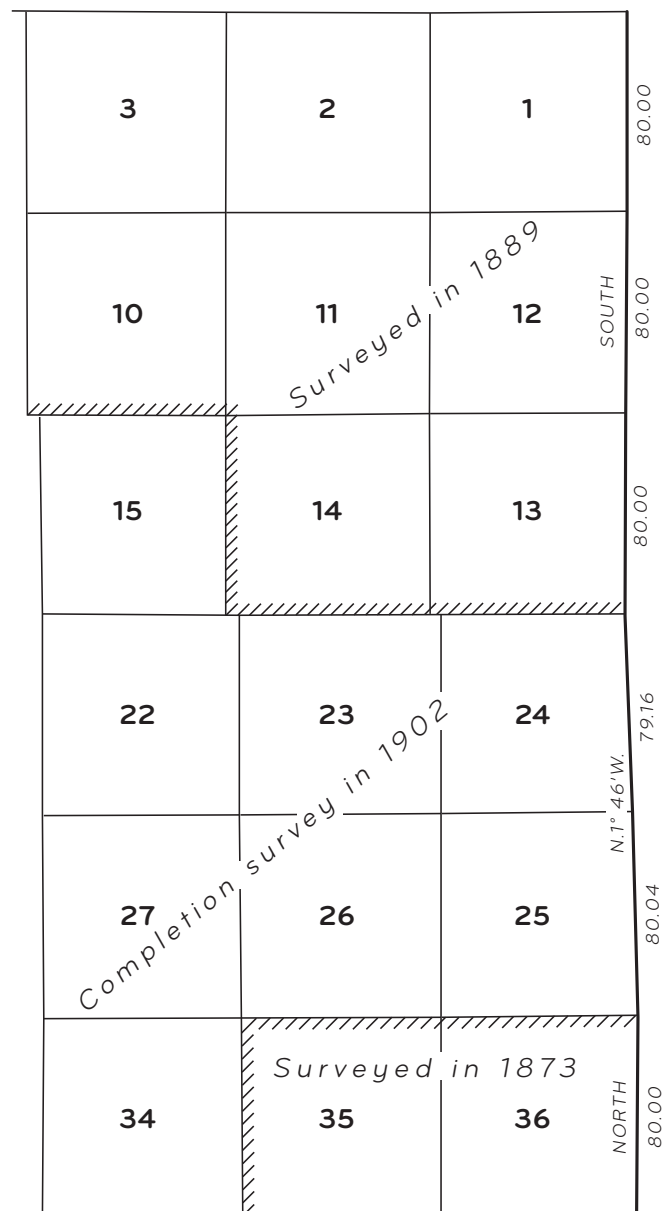
**7-51.** Some township boundaries are not established as straight lines and are termed “irregular” exteriors. Parts of the boundaries were surveyed from opposite directions and the intermediate portion was completed later by random and true line, leaving a fractional distance. Such irregularity involves some material departure from the basic rules for the establishment of original surveys. A modified form of single proportionate measurement is used in restoring lost corners on such boundaries. This is also applicable to a section line or a township line that has been shown to be irregular by a *previous* retracement (figure 7-7).

**7-52.** In order to restore one or more lost corners or angle points on such irregular exteriors, a retracement between the nearest known corners is made on the record courses and distances to ascertain the direction and length of the closing distance. A position is calculated for each lost corner or angle point at the record position. The closing distance is then reduced to its equivalent latitude and departure.

The adjustment to be applied along the line is single proportion, and the adjustment to be applied perpendicular to the direction of the line is compass rule.

On a meridional line the *latitude* of the closing distance, presuming retracement is made on record courses and distances, is distributed among the courses in proportion to the *latitude* of each course. The *departure* of the closing distance is distributed among the courses in proportion to the *length* of each course. That is, after the excess or deficiency of latitude is distributed, each calculated angle point is moved east or west an amount proportional to the total record distance from the starting point.

On a latitudinal line the calculated angle points will be placed to suit the usual adjustments for the curvature. The *departure* of the closing distance, presuming retracement is made on record courses and distances, is distributed among the courses in proportion to the *departure* of each course. Then each calculated angle



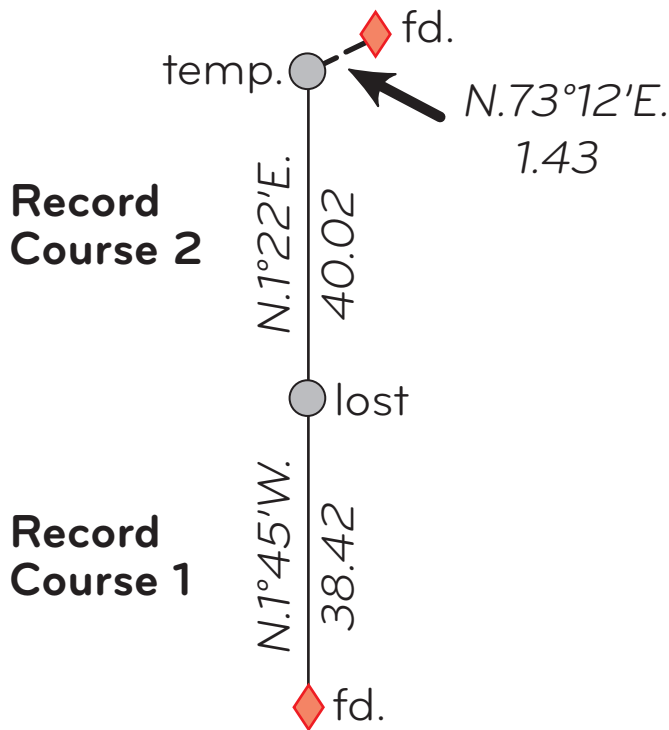
**Figure 7-7.** Irregular exterior resulting from the piecemeal survey of a township line.

point is moved north or south an amount proportional to the *total distance* from the starting point. The latitude of the closing distance will be applied proportionately to the latitudinal component of each course an amount proportional to the total record distance from the starting point.

Angle points and intermediate corners will be treated alike (figure 7-8).

### Angle Points of Meander Lines

**7-53.** (The previous edition of the Manual referred to this method as the Angle Points of Nonriparian Meander



When reestablishing a position on an E-W line the formulas for the restored latitude and departure below would be interchanged.

latitude	$C = \frac{\text{total lat retraced dist}}{\text{total lat record dist}}$	(record lat of each course)
departure	$C = \frac{\text{total dep retraced} - \text{total dep record}}{\text{total record dist}}$	(record distance) + record dep

Line	bearing	distance	lat	dep
C1 record	N. 1° 45' W.	38.42 ch	N 38.4021	W 1.1733
C2 record	N. 1° 22' E.	40.02 ch	N 40.0086	E .9545
total record			<b>N 78.4107</b>	<b>W .2188</b>
tie	N. 73° 12' E.	1.43 ch	N .4133	E 1.3690
total retraced			<b>N 78.8240</b>	<b>E 1.1502</b>

latitude	$C1 = \frac{78.8240}{78.4107} (38.4021) = 38.6045$
departure	$C1 = \frac{1.1502 - (-.2188)}{78.44} (38.42) + -1.1733 = -0.5028$
	C1 = N. 0° 44' 46" W., 38.608 ch

latitude	$C2 = \frac{78.8240}{78.4107} (40.0086) = 40.2195$
departure	$C2 = \frac{1.1502 - (-.2188)}{78.44} (40.02) + .9545 = 1.6530$
	C2 = N. 2° 21' 13" E., 40.254 ch

Figure 7-8. An irregular boundary adjustment.

Lines.) In some cases it is necessary to restore (or possibly to locate for the first time) the angle points, within a section, of the record meander courses for a stream, lake, or tidewater, required under the special rules applicable to meander lines. This is commonly called the compass rule adjustment.

This meander line adjustment presumes that errors are random and that the effects of angular error are equal to the effects of error in distance. The positions of the meander corners on the lines of the official survey(s) are determined first. The record meander courses and distances are then run and temporary angle points are marked. The closing (residual) error is shown by the direction and length of the line from the end of the last course to the objective meander corner. The closing (residual) error is distributed proportionately along each record course. The closing (residual) error is distributed on the same plan as in balancing a survey for the computation of the areas of the lottings as represented on the plat.

The general rule is that the adjustment to be

applied to the  $\left\{ \begin{array}{l} \text{latitude} \\ \text{departure} \end{array} \right\}$  of any course is to

the resolved  $\left\{ \begin{array}{l} \text{latitude} \\ \text{departure} \end{array} \right\}$  of the closing error as

the length of the course is to total length of all the courses. Each adjustment is applied in a direction to reduce the closure. If the *northings* are to be *increased*, then the *southings* will be *decreased*. A line due *east* would then be given a correction to the *north* (in effect to the *left*); a line due *west*, also to the *north* (in effect to the *right*). Each incremental correction is determined and applied in proportion to the length of the line.

The adjustments for the positions of the several angle points are accomplished simply by moving each temporary point on the bearing of the closing (residual) error an amount that is its proportion of that line, counting from the beginning. The particular distance to be measured at any point is to the whole length of the closing (residual) error as the distance of that point from the starting corner is to the sum of the lengths of all the courses (figure 7-9).

The same principle is followed to plot lottings of dependently resurveyed sections in their true relative positions when the record meander line and the true shoreline differ greatly because of distortion or other discrepancy.

### Grant Boundaries

**7-54.** In many of the States there are irregular grant and reservation boundaries that were established prior

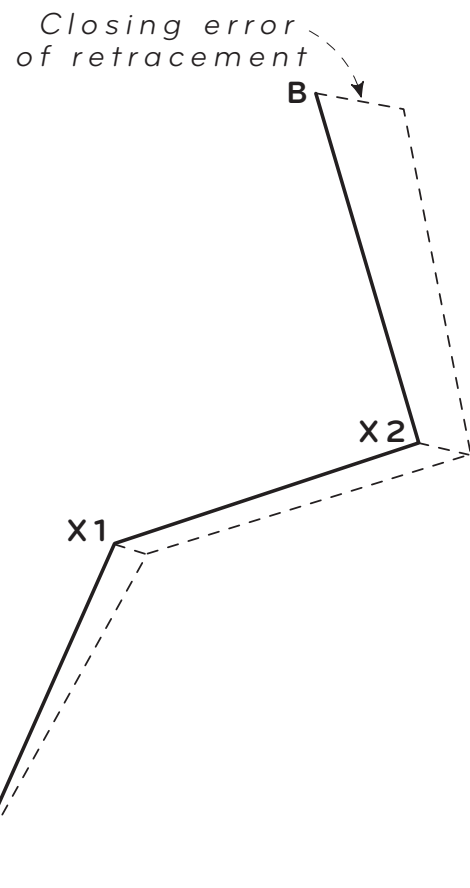


Figure 7-9. Adjustment of angle points on a meander line.

to the public land rectangular surveys. In these cases, the township and section lines are regarded as the closing lines. The grant boundary field notes may call for natural objects, but these are often supplemented by metes-and-bound descriptions. The natural calls are ordinarily given precedence then the existent angle points of the metes-and-bounds survey. The lost angle points are then restored by uniformly orienting the record courses to left or right and adjusting the lengths of the lines on a constant ratio. Both angular and linear corrections are made in the direction needed to reduce the falling of the trial lines laid down according to the record. This is essentially a rotate and scale procedure.

The retracement of the grant boundary is begun at an identified corner. Calls for natural objects are satisfied and the existent angle points are recovered. Then, between the identified or acceptable points, the position of lost angle points is determined by the following steps, which serve to apply an identical scale factor and rotation to each of the lines on the grant boundary between the two identified or acceptable points:

- (1) Reduce the *record* courses and distances to the total differences in latitude and departure.

Compute the direction and length of a line connecting the identified points.

(2) Determine the *actual* differences in latitude and departure between the same identified points by retracement. Compute the direction and length of the connecting line based on these figures.

(3) The angular difference of direction between the connection lines computed in (1) and (2) gives the amount and direction of the adjustment to apply to the *record* bearing of each intermediate course.

(4) The ratio of the length of the line computed in (2) to that computed in (1) gives the coefficient to apply to the *record* length of each intermediate course.

After the adjustments have been applied to the record courses, all in the same angular amount, and to the record distances, each one proportionally for length, and the locations for the angle points thus determined on the ground, additional search for evidence of the record markers must be made. The adjusted locations for the angle points are in the most probable original position. If no further evidence is recovered, and the angle points are regarded as lost, the adjusted points are then monumented.

In figure 7-10, A and B are identified points of the original boundary. It is desired to restore intermediate points T, S, R, J, I, H, and G, which have been temporarily

marked at Tt, St, Rt, Jt, It, Ht, and Gt in conformation with the original record starting from point A. The record position of point B in relation to point A is designated Bt. The adjustment has been made in the four steps already described.

The same procedure may be followed whenever it is desired to retain the *form* of the traverse being adjusted since the interior angles are unchanged and the increase or decrease in lengths of lines is constant. The adjustment may be likened to the use of a pantograph or to a photographic enlargement or reduction. Mechanically, this process requires that the record distances of the traverse legs between identified points be reduced or increased simultaneously with the rotation of the record bearings until the two identified points coincide. The resulting adjustment applies a rotation that is uniform in both amount and direction, maintaining the original record angles and thus the original shape of the grant boundary, and adjusting record distances by a single, constant ratio.

7-55. There often is no hard and fast rule for reestablishing lost corners of tract surveys and special surveys (see section 10-213 for lode mining claim surveys). When the original surveys were made faithfully, the application of the principles of record distances, record angular relationships, and record relationships between improvements and adjoining surveyed parcels, in combination with the presumption that the original intent was to be conformable with the statutes governing orientation, dimensions, and area, will substantially meet the objects stated above.

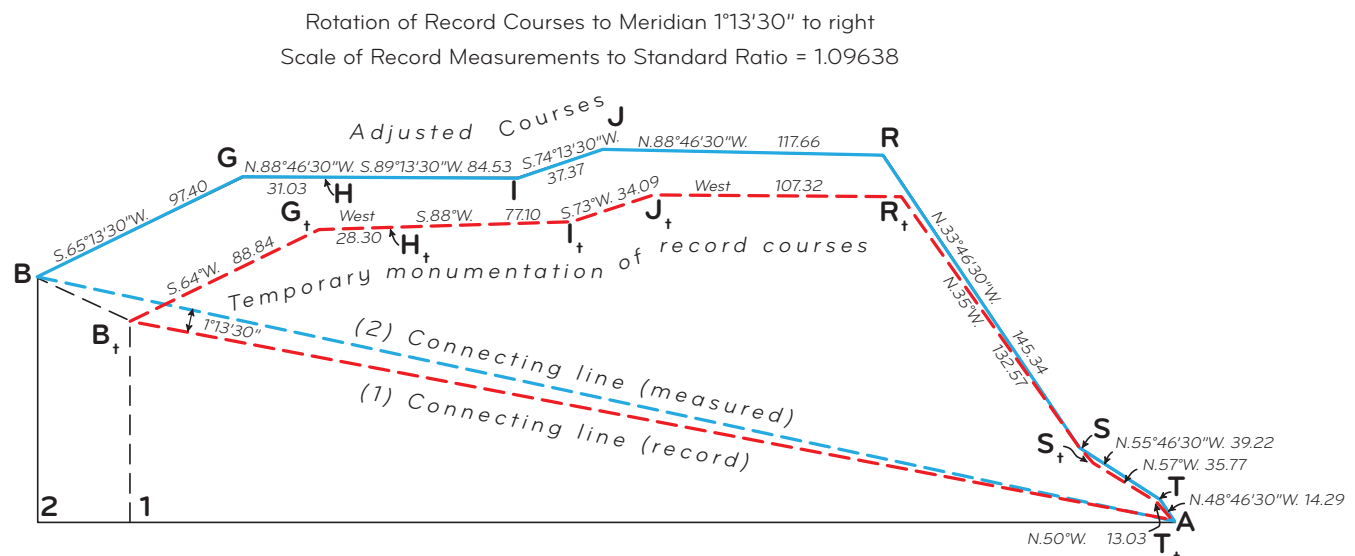


Figure 7-10. Adjustment of a grant boundary.

## Original and One-Point Control

**7-56.** Where a line terminates with measurement in one direction only, a lost corner should be restored by record bearing and distance, counting from the nearest identified or restored regular corner. Examples will be found where lines have been discontinued at the intersection with large meanderable bodies of water or at the border of what was classed as impassable ground.

The use of one-point control is only applicable where the prior survey was discontinued at a recorded distance or where it can be shown conclusively that the line(s) to all other interdependent corners were never established. If the line was discontinued, the field notes may be followed explicitly. An index correction should be applied to the record bearing and/or distance when applicable.

## Index Correction

**7-57.** In cases where a retracement has been made of many miles of the original lines, between identified original corners, and there has been developed a definite and consistent surplus or deficiency in distance, or a definite and consistent angle from cardinal that characterizes the original survey, it is proper to make allowance for the average difference(s). Such adjustment will be incorporated automatically in all cases where there exists a suitable basis for proportional measurement. Where control in one direction is lacking or non-existent, an index correction, if supported by conclusive evidence, should be applied to the record courses and/or distances. If there is no conclusive evidence of applicability of an index correction, the record courses and distances should be allowed to prevail.

## Mixing Records

**7-58.** When intermixing recent and relatively accurate survey or resurvey data with older and presumably less accurate data, both records may be used in determining the proportionate measurement corner position. An index correction may be applied to the record measurements before determining the proportionate measurement of the corner position. When use of the newer data provides the better method to reestablish the position of a lost corner in its original position, the newer data should be used solely. This method is consistent with the general rule that manifest blunders in measurement are removed from the general average difference and placed where the blunder was made prior to applying proportionate measurement.

## Miscellaneous Control

**7-59.** The actual field conditions do not always furnish the basis for the application of the rules. While developing a plan of reconstruction to apply in the most unusual of cases, the first consideration relates to a more or less arbitrary limitation of the control to be adopted. No definite rule can be laid down, except that there will be the closest possible adherence to the basic examples already given in the text and to the method of the original survey that is to be restored. The methods heretofore outlined readily harmonize surveying practice with legal decisions concerning the restoration of lost corners.

A strictly consistent mathematical restoration of a lost corner can be obtained by allowing every accepted corner within a reasonable radius to enter into the control. Each corner is given a weight inversely proportional to its distance from the lost corner. The principle will lead to the same result in some cases as by the methods previously outlined, but may yield a slightly different result under some circumstances. A miscellaneous control based upon such mathematical principle will not be adopted, except as specifically approved by the proper supervising officer in the absence of a suitable basis for a regular control.

The problem in the field will be developed by a series of retracements each beginning at an accepted corner, following out the record courses and distances, and terminating at a calculated position in the vicinity of the objective lost corner. Each calculated position is given a weight inversely proportional to the distance from the accepted corner to which it is related. The several calculated positions are then combined; the first two to be resolved into a point on the line between them, dividing the whole distance into two parts that will make the interval from either calculated position inversely proportional to the weights previously assigned, and the latter point is given their combined weights. The last point is then correlated with the third calculated position on a similar plan. Three or more corners will thus exercise their influence upon the final resultant position for the corner that is to be restored. The result will be the same no matter what the order of connecting the calculated position is, but the omission of any element of the control or the introduction of an additional corner will alter the final position. Therefore, the field of influence should be selected to obtain a resulting balanced position that cannot be materially changed by the introduction of other points of control (figures 7-11 and 7-12).



Portion of 1893 Record

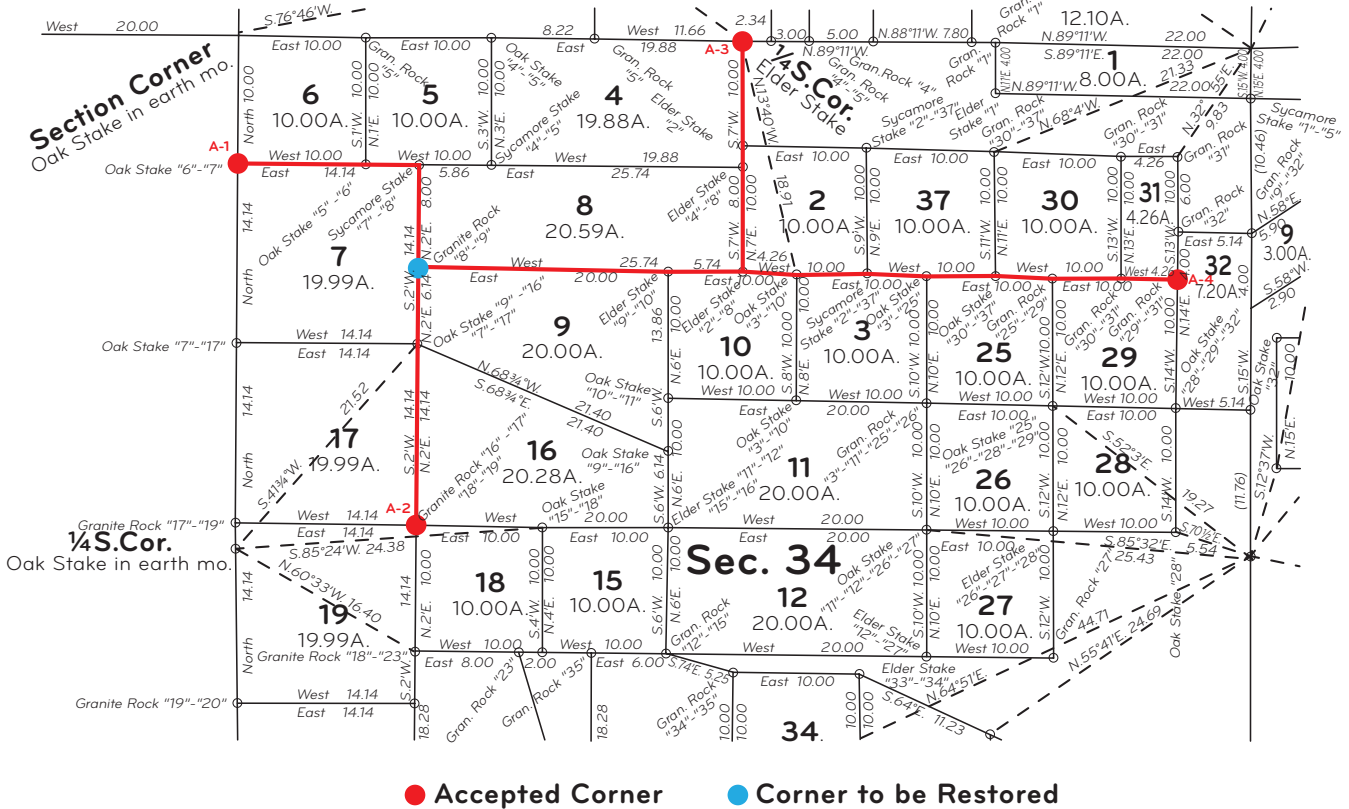


Figure 7-11. Miscellaneous control—record.

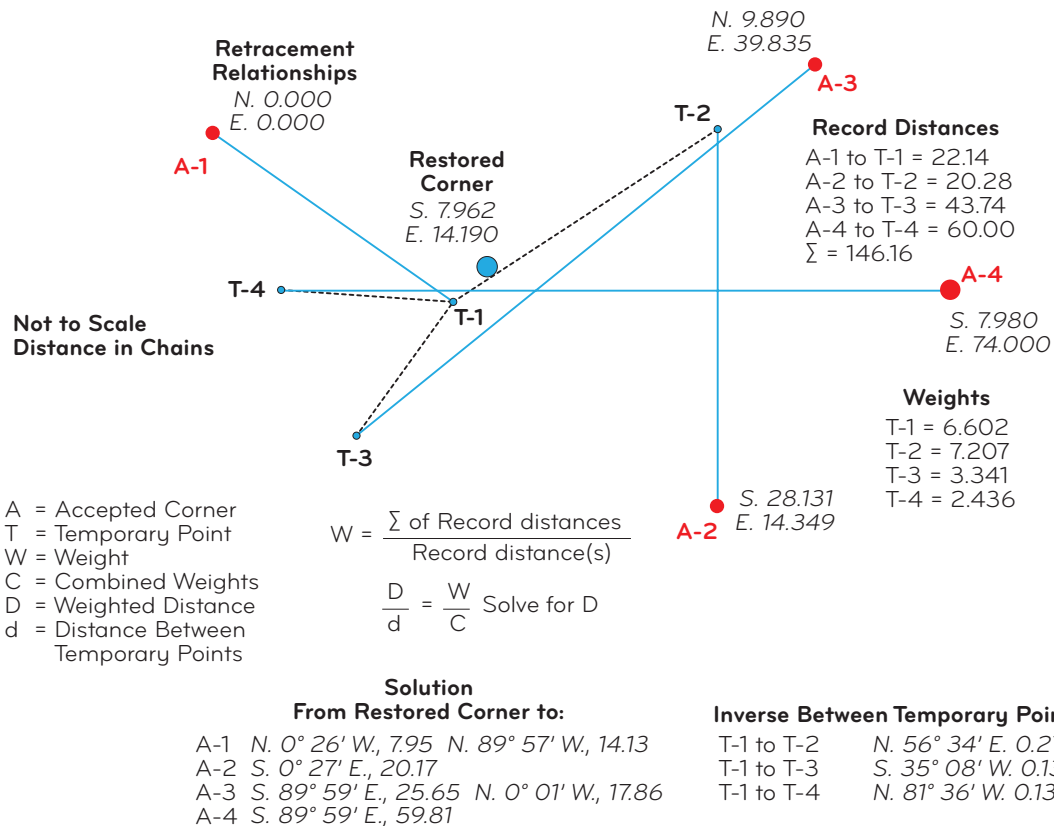


Figure 7-12. Solution using miscellaneous control.

## Special Cases

**7-60.** The cadastral surveyor will call upon the supervising officer for advice in difficult cases who may direct the field surveyor to proceed with additional retracements in order to develop any data that should be considered before a decision is rendered.

In trials of boundary suits, the court or administrative board generally consider many questions besides those concerned with the technical problems. This Manual treats nontechnical matters consistent with the discretionary authority delegated to the BLM to survey and mark Federal interest lands.

**7-61.** In unusual cases where the evidence of the survey cannot be identified with ample certainty to enable the application of the regular practices, the county or other local surveyors should submit their questions to the proper State Office of the BLM. Letters of inquiry should include a description of the lines in question and the facts as developed by the retracement. In cases where no Federal interest lands are involved, the methods and explanations of the BLM should be regarded as advisory only.

## Summary

**7-62.** When reestablishing a lost corner, an attempt must be made to harmonize the process with the methods used in the original survey. Factors to consider in determining whether the decision is supported by the record include:

- (1) Is the end product in harmony with the original plat?
- (2) Are the corner points, lengths of lines and bearings of lines in harmony with the original and each other?
- (3) Is there a degree of harmony between the topographic calls in the retracement and those of the record?
- (4) Are the elements of evidence nearest the particular corner in question given the greatest weight and are they harmonious with each other?
- (5) Is the form of proportionate measurement used that most nearly harmonizes surveying practices with legal and equitable considerations in determining boundaries?
- (6) Is there harmony between the end product and the evident faithfulness of the original survey?

The above methods of restoring lost corners have been described in a way that allows adjustments to be made in the field with minimal computations. Surveying software can incorporate most of these adjustments. Cardinal equivalent and the Public Land Survey System datum (section 2-9) will be taken into account in almost all of these calculations. Reference should be made to previous editions of the Manual for more detailed field techniques.

## Chapter VII Notes

The notes presented here elaborate on a topic presented in chapter VII. The section number corresponds to the section number in the chapter and is followed by "(n)" to indicate that it is an additional note.

### *"Half-Mile Posts," Alabama and Florida*

**7-36(n).** In the early practice in parts of Alabama and Florida, so-called "half-mile posts" were established at distances of 40 chains from the starting section corner. The term was applied where the line might be more or less than an exact 80 chains in record length, and where by later methods the latitudinal lines have been run as "random and true." The practice contemplated that in some cases these subdivisional lines be run in cardinal directions to an intersection, where the next section corner would be placed, and either or both lines might be more or less than 80 chains in length. In some cases the section corners were placed across the township at intervals of 80 chains on one of the cardinal lines, and the other lines were run on random only. On the first plan the "half-mile post" would not be at midpoint unless the line turned out to be 80 chains in length. On the second plan the "half-mile post" on the lines first run would be in true position for the quarter-section corner, but on the lines last run they would usually not be on true line, nor at mid-point.

In both cases field notes were written showing a true line direction and midpoint distance for a quarter-section corner. This was done to meet the objection that the "half-mile post" did not satisfy the requirements of law, but the true line was not actually run on the ground, nor was a monument constructed at midpoint. In these cases only the true line field notes need be regarded if the evidence of the "half-mile post" has disappeared; but where the latter can be identified the point must be given proper weight for control. Each set of field notes requires its individual consideration, as the practices were not uniform even in the same surveying district.

The applicable rules for the restoration of the true line midpoint positions for the quarter-section corners in the above practices are derived from the Act of February 11, 1805 (2 Stat. 313; Rev. Stat. 2396; 43 U.S.C. 752), which requires that "the corners of half and quarter sections, not marked on the said surveys, shall be placed as nearly as possible equidistant from those two corners which stand on the same line."

The rules may be stated specifically as follows:

- (1) In case the "half-mile post" and quarter-section corner are recorded as being at a

common point, the identified "half-mile post" will be restored as the quarter-section corner.

- (2) If there is evidence of the position of the section corners in both directions, and if the record *leaves doubt* as to the establishment of the "half-mile post" on the true line, the quarter-section corner will be monumented at midpoint on the true line, disregarding the record of the "half-mile post."

- (3) In the absence of evidence at one or both section corners and where the record *leaves doubt* regarding the running and marking of the true line, the "half-mile post" will be employed on a north and south line for the control of the latitude of the quarter-section corner, or on an east and west line for control of its position in departure, using the record correction for distance. The alinement of the section boundary and the position of the quarter-section corner on the true line will be adjusted to the location of the two section corners *after* the double proportionate measurements have been completed.

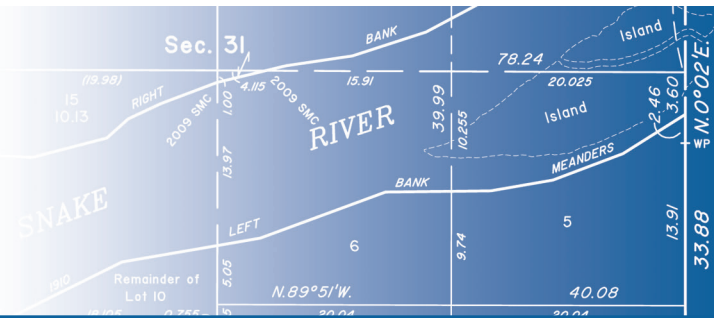
- (4) Where the field notes show proper location for alinement and record correction for distance, the "half-mile post" will be employed for the full control of the position of the quarter-section corner, and for the restoration of the lost section corners. The position of the quarter-section corner in latitude on a north and south line, or in departure on an east and west line, will be ascertained by making use of the record correction for distance from the "half-mile post." The alinement from the position of the "half-mile post" to the point for the quarter-section corner will be determined by the position of the section corner to the south, if the record correction for distance is to be made to the north; the section corner to the north will be used if the record correction for distance is to be measured to the south; and similarly on east and west lines.

- (5) The evidence of the "half-mile post" will not be destroyed.



## Chapter VIII

# Resurveys and Water Boundaries



## Introduction

**8-1.** As a class, water boundaries represent some of the most challenging survey problems. In this chapter, water boundaries are divided into several subtopics in order that the elements of each type of problem can be brought out clearly. This chapter addresses the dependent resurvey of the original meanders, issues of navigability, bed ownership and division, accretion, erosion, reliction, avulsion, partition lines for the apportionment of accretions and relictions, accretion after survey but prior to entry, omitted lands, erroneously omitted lands, unsurveyed islands, and beds of nonnavigable rivers and lakes.

Dependent resurveys involving water boundaries usually involve two or more of these elements, requiring an overall analysis to find out which elements are involved. A study of the available historic maps and aerial photographs is made in all but the simplest cases.

## Meanders

**8-2.** Meandering and original surveys is discussed in detail in sections 3-158 through 3-207. In summary, the traverse that approximates the margin of waters is termed a meander line. The original survey of water boundaries described the conditions as they existed at the date of that survey. This process is presumed accurate at the date of the survey as future changes are expected. A meander line is not normally surveyed as a boundary but only as a representation of the actual boundary, which is the ordinary or usual upper limit of the water body. Normally, when the Federal Government conveys title fronting a navigable inland body of water, the intention is that the upland ownership extends to the ordinary high water mark (OHWM). For lands fronting a non-navigable inland body of water, the intention is that the upland ownership extends to the medial line. Finally, for lands fronting tidal water, the intention is that the ownership extends to the line of mean high tide (line of MHT). However, meander lines may become “fixed

and limiting boundaries” under special circumstances described in sections 8-94, 8-169, and 8-179.

**8-3.** The original survey of water boundaries described the conditions as they existed at the date of that survey. They reflect the original surveyor’s effort to follow the OHWM or line of MHT. Unlike upland boundaries, water boundaries are ambulatory. The water boundary is a concept that must be applied by observation of the river, lakeshore, or ocean beach and other tidal water bodies. The actual survey work merely approximates the infinite indentations of riverbanks, channels, or shorelines.

As the work progresses along the boundary under survey, the surveyor must continually assess the terrain and vegetation to compare the variations to the legal concept and establish survey positions that most adequately approximate the actual boundary. Surveys of water boundaries that involve Indian lands, besides enjoying the normal complexities of riparian principles, are highly variable in nature by virtue of the specific language used in the original Treaty, Executive orders, or congressional acts that describe the Indian interest. The surveyor must be cognizant of these differences and should consult appropriate legal counsel to assure the correctness of the survey prior to its completion.

**8-4.** Procedures for the dependent resurvey of water boundaries are separate from the original survey requirements. The resurvey must consider the historic procedures in place at the date of those original surveys. In particular, because of advances in technology plus the differences in value of riparian lands, the surveyor may find that there are substantial differences in the location of the current boundary from the original locations. These differences may exceed the differences that can be explained from normal changes due to accretions, erosion, reliction, and avulsions in the interim.

**8-5.** The concept of following the footsteps of the original surveyor is often not of prime importance in



the resurvey of water boundaries. The dependently resurveyed boundary is a concept established largely by common law that the surveyor shall apply to the conditions that are found along riverbanks, channels, or shorelines. In addition to any physical changes made by water action, State laws regarding water boundaries may be in conflict with the Federal rules and could influence the outcome, particularly where alienated lands are involved.

**8-6.** When important new subjects are encountered in this chapter, a brief definition of terms is provided in the text. If a more complete definition of a term is required, the reader should refer to the Manual supplement, *Glossaries of BLM Surveying and Mapping Terms*.

### Meanders and Meandering— Inland Waters

**8-7.** Inland waters are water bodies not influenced by the daily tides. Survey and resurvey procedures for lands along tidal waters are set out in sections 8-190 through 8-194.

**8-8.** Bodies of water that are meandered and reported on surveys are called meanderable waters and include the following:

A river is defined as a watercourse having banks to contain an ordinary flow of water; although, there may be no flow at various times of the year.

A lake is defined as a quiescent pool of water in a flowing river. A lake with no outlet is defined as a terminal lake, e.g., the Great Salt Lake in Utah.

**8-9.** Meanderable bodies of water include all navigable waters and also nonnavigable rivers that are 3 chains and upwards in average right angle width and nonnavigable lakes 50 acres and upwards in surface area. Nonnavigable rivers of importance, i.e., used as a boundary are meanderable even if less than 3 chains in width. The distinction between navigable and nonnavigable water bodies can be complex and is further detailed beginning in sections 8-21 and 8-32.

### Meandering Along Inland Waters

**8-10.** Meander corners are corners of the survey that are established where township exterior, section, or other

important survey lines intersect the margin of navigable waters or meanderable nonnavigable water. The purpose of meander corner monuments is to preserve the alignment of and the distance along the section line, and to provide a monumented beginning and ending point for the meanders. Where the meander corner location may be subject to erosion, bank caving, ice shoving, or wave action, reference monuments or a witness corner meander corner (WCMC) will be established as near as practicable.

**8-11.** Meander corner monuments are to consist of the regulation posts used for monumentation of the public lands surveys, described in more detail in chapter IV. Corner accessories to meander corners are to be established on the upland side of the meander lines running into or from the corner. Typical markings are found in chapter IV.

**8-12.** Meander corners are established and meander (sometimes called angle) points are located along the banks of meanderable rivers and lakes, and along the banks of islands that were formed in those water bodies before the date of statehood. Meander corners are also established along the banks of islands in meandered nonnavigable rivers and lakes that formed in those water bodies after the date of statehood but prior to alienation of the upland.

**8-13.** Meander lines are only run in front of public domain or other Federal interest lands. When it is necessary to show the sinuosities of a water body in front of alienated lands for platting purposes, medial line computations, establishing zero accretion points, or controlling proportionate corners, an informative traverse is run and may be included on the plat and field notes. An informative traverse is executed similarly to a meander line but neither establishes nor defines riparian rights of any kind in the adjacent upland. The informative traverse merely indicates the topography in front of the entered, claimed, or patented land. In addition, new areas are not returned. The result is represented on the plat as an informative traverse with different line weight or line style from shown meanders.

**8-14.** Remeandering is the process of establishing new meanders in front of previously meandered Federal interest lands. In the event of accretions to or relictions on such lands, the new meander line will be between the margin of the water and the former meander line.

**8-15.** Where it appears that upland was erroneously marked as lying below the original meander line and

thus omitted from survey (omitted lands), the original meander line becomes a fixed and limiting boundary. New meanders are returned and new acreage and lots shown on the plat for the formerly omitted areas.

**8-16.** When sections bordering meandered bodies of water are subsequently subdivided, it is common for the shore line to have materially changed during the intervening years between the date of the subdivision of the township and the date of the subdivisional or allotment survey, through the processes of accretion, erosion, or the recession of the water. If it is desirable to remeander the body of water in order to show the true conditions at the date of the section subdivision, the plat should show new lottings and/or areas for unpatented lands within the invaded sections (section 9-109 and figure 9-9).

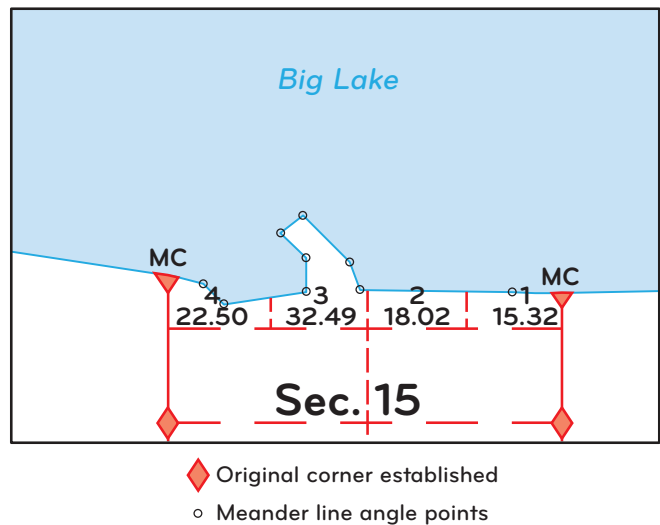
**Restoration of Meander Lines During Resurvey**

**8-17.** Following the perpetuation of obliterated meander corners or reestablishment of lost meander corners, it may be necessary to place the original meander line on the ground. This is done to assist in understanding the processes by which the changes occur, especially in identifying avulsions. Calls for bank heights, sloughs, vegetation, and other physical features in the previous record are compared with current conditions to understand why the changes occurred. The restoration of angle points along meander lines is made using the compass rule adjustment method described in section 7-53.

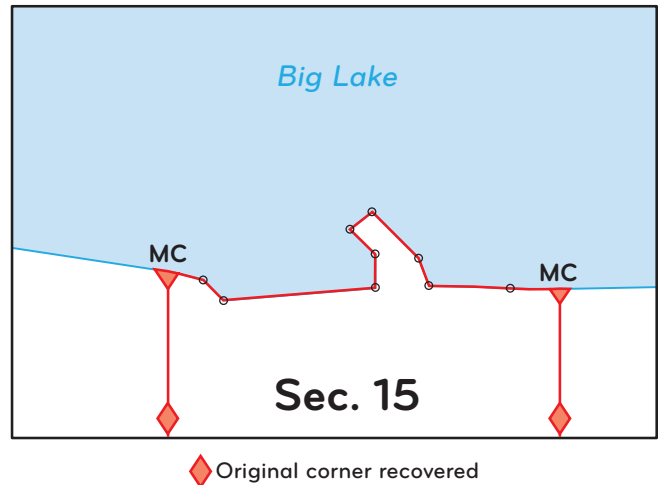
**8-18.** In situations where the record adjusted angle points fall in deep water or other impassible terrain, the restored angle points will be calculated based on the above field procedure and the coordinates of the restored angle points then established by a calculated traverse. A graphical layout of the entire traverse at a suitable scale is recommended for a check on the work.

**8-19.** The existence of a gross error or blunder in the original meander line record is sometimes apparent when a sharp topographic feature is reflected in the original record but is offset at a considerable distance from its restored location, hence the rationale for placing the original meanders on the ground (figures 8-1 through 8-3). Using the principle of placing the blunder where the blunder occurred, the record should be judiciously corrected so that the restored meander line adequately reflects the topography.

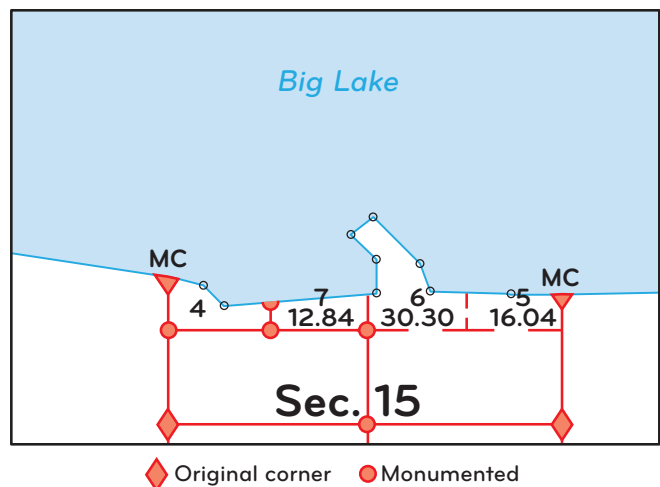
Past record errors have included reversed meander course order, an error in the inversed final course, the original surveyor erroneously following the banks of



**Figure 8-1.** A portion of the 1871 original survey plat showing a lake peninsula.



**Figure 8-2.** A portion of the 2009 retracement showing the same lake peninsula.



**Figure 8-3.** A portion of the 2009 resurvey and the subdivision of section 15.

another water body, e.g., meandering a stream entering the river intended to be meandered, meandering the top of vertical banks some distance back from the water's margin, meandering during flood stage rather than "ordinary high water" (not necessarily error but may explain an excessively wide river), or transcription errors.

**8-20.** Angle points of a restored adjusted record meander line are not ordinarily monumented except as necessary for administration or management purposes. These are monumented when the restored adjusted record meander line becomes a fixed and limiting boundary of Federal interest land or when accretions are lotted.

## Navigability

### Nonnavigable Waters

**8-21.** Nonnavigable bodies of water are rivers and lakes that have no history of use in navigation nor have the susceptibility of being used for commercial transportation in their ordinary condition at the date of statehood. They are the small natural ponds, rocky creeks, and even usually dry washes, and arroyos. They do not fit the description of streams or lakes that are legally navigable waters; navigable waters are more carefully defined below.

**8-22.** Nonnavigable watercourses, when crossed by lines of the regular survey and resurvey, are noted as items of topography. The field notes should reflect the distance along the line to the center of the watercourse, the direction of the flow, and average width. The shores of such small lakes will be noted as items of topography with the distance along the survey line and the bearing of the shoreline in the field notes.

**8-23.** Nonnavigable streams and lakes are meandered under certain conditions. Title to the beds remains in the United States until the shore lands have passed into private ownership (*United States v. Oregon*, 295 U.S. 1 (1935)). The Government's conveyance of title to a fractional subdivision fronting upon a nonnavigable body of water, unless specific reservations are indicated in the patent, carries ownership to the middle of the bed *in front of* the basic holding (*Oklahoma v. Texas*, 261 U.S. 345 (1923); see also 43 U.S.C. 931).

**8-24.** Well-defined nonnavigable watercourses more than 3 chains in average right angle width will be meandered on both banks between consecutive meander corners, unless otherwise directed by special instructions.

**8-25.** Nonnavigable lakes of 50 acres and upwards in extent will be meandered unless otherwise directed by special instructions. The survey procedure is the same as for a navigable lake.

**8-26.** It is necessary at times to survey the beds of nonnavigable streams and lakes, or the portions of the beds owned by the Government, in connection with the administration of the Federal interest lands, e.g., locating the medial line of the river which is the boundary of an Indian reservation. Where all the shore remains in public ownership, the survey is simply an extension of the regular rectangular system.

More commonly, it is desired to establish partition lines between alienated and Federal interest lands. In either case, if the area is covered by water, as in the case of the survey of the bed of a nonnavigable water body, the survey cannot be monumented in the regular manner, and many of the lines cannot be surveyed on the ground. The plat then represents a survey made largely by protraction. The procedure will be outlined in detail in the special instructions.

**8-27.** Where federally owned lots are dependently resurveyed along one bank of a meandered nonnavigable river and are opposed by entered, claimed, or patented lots along the opposite bank, generally the boundary line between the lots is located along the medial line of the river. The medial line is halfway between the opposite OHWMs of the river as of the time of the resurvey. See section 8-62 for more information about medial lines and exceptions to the general rule.

**8-28.** The field work usually consists of (1) a dependent resurvey of the lands bordering on the area to be surveyed; (2) the subdivision of the upland sections when necessary to determine the boundaries of Federal interest riparian subdivisions; (3) the monumentation of as many corners as practicable; (4) the protraction of section lines onto the bed to the extent needed for making computations; and (5) the establishment of medial and partition lines if this is to be done on the ground.

**8-29.** Nonnavigable rivers have been used as boundaries of reservations, borders between States, or other special purposes, e.g., the Yakima River in Washington State (a portion of the Yakama Indian Reservation boundary), the San Juan River (a portion of the Navajo Reservation boundary), or the Red River (a portion of the Texas and Oklahoma border). In some instances, the boundary of a special area follows one bank or the other rather than in the channel. It is important that the precise

location of the boundary along such rivers be examined by reference to the applicable treaty, Executive order or congressional act creating the reservation or State. These treaties, Executive orders, and acts override the conventional use of the medial or median line as the boundary. For example, the western bank of the Chattahoochee River forms the boundary between the States of Georgia and Alabama above the head of navigation and the Ohio River's northerly line of ordinary low water forms the southerly boundary of Ohio.

**8-30.** The meander line of a lake lying within a section is initiated at the established special or auxiliary meander corner, as the case may be, and continued around the margin of the normal lake at its OHWM, to a closing at the point of beginning. All proceedings are fully entered in the field notes. The process for establishing a SMC or AMC on the margin of a lake is described in sections 3-188 and 3-189.

**8-31.** Artificial lakes and reservoirs are not segregated from the Federal lands, unless specially provided for in the special instructions, but the true position and extent of such bodies of water are determined in the field and shown on the plat.

### Navigable Waters and Navigability

**8-32.** In early European history, the right to use the waters was reserved to the ruler. Roman law made the distinction between nonnavigable and navigable waters and this concept was incorporated into the Common Law of England and subsequently into American law. English Common Law held that the beds of all tidally influenced waters belonged to the Crown up to the edge of land that could be cultivated for agriculture. When the early courts and settlers in New England tried to apply those rules it became clear that rivers such as the Hudson and the Ohio were clearly navigable even though not tidally influenced.

**8-33.** Upon the admission of a State into the Union title to the beds of navigable bodies of water inures to the State as an incident of sovereignty. In *Pollard's Lessee v. Hagan*, 44 U.S. 212 (1845), the Supreme Court held that:

First, The shores of navigable waters, and the soils under them, were not granted by the constitution to the United States, but were reserved to the States respectively. Secondly, The new States have the same rights, sovereignty, and jurisdiction over this subject as the original States.

**8-34.** Two early U.S. Supreme Court decisions reflected the American solution of navigability. Excerpts from those decisions follow:

Those rivers must be regarded as public navigable rivers in law which are navigable in fact. And they are navigable in fact when they are used, or are susceptible of being used, in their ordinary condition, as highways for commerce, over which trade and travel are or may be conducted in the customary modes of trade and travel on water. And they constitute navigable waters of the United States within the meaning of the acts of Congress, in contradistinction from the navigable waters of the States, when they form in their ordinary condition by themselves, or by uniting with other waters, a continued highway over which commerce is or may be carried on with other States or foreign countries in the customary modes in which such commerce is conducted by water. *The Daniel Ball*, 77 U.S. 557 at 563 (1871).

The true test of the navigability of a stream does not depend on the mode by which commerce is, or may be, conducted, nor the difficulties attending navigation. *The Montello*, 87 U.S. 430 at 441 (1874).

The capability of use by the public for purposes of transportation and commerce affords the true criterion of the navigability of a river, rather than the extent and manner of that use. *The Montello*, 87 U.S., at 441.

**8-35.** The Federal courts have the final authority to determine navigability when Federal interests are involved, such as upland with public domain land status, or interstate commerce. However, for management purposes, there are times when an administrative determination of navigability of a water body is needed to ascertain whether title to land remains in the United States. The Federal court decisions for land title purposes may be restated as far as may be required for the first approximation of navigability as follows (see Property Clause, U.S. Constitution, Article 4, Section 3, Clause 2):

- (1) Rivers and lakes that are navigable in fact are those that have a history of use as highways of commerce over which trade and travel were conducted at the time of statehood.
- (2) Rivers and lakes navigable in fact at the date of statehood are navigable in law.



(3) “Navigable waters of the United States” are those to which congressional acts apply and they must interconnect to permit navigation to navigable waters in other States or countries. Navigable waters of the United States do not confer title to the soil under those waters to the United States.

(4) “Navigable waters of the State” are those navigable in law that does not interconnect with navigation in other States or countries. The navigable waters of the State include ownership of the soil under the waters.

(5) Rivers and lakes in States that were undeveloped at the time of statehood will be navigable in law if they were susceptible of being used in their natural condition as highways of commerce, over which trade and travel could have been conducted, at statehood.

### Ownership of the Beds of Navigable Waters

**8-36.** Federal courts have jurisdiction under the Constitution over admiralty, commerce, and land title (ownership), and by statute over water pollution. Before the American Revolution the Colonies as well as some individuals were awarded grants of land from the Crown. Occasionally the wording of these grants would include the ownership of the beds of bays and other navigable waters. The Constitution preserved all such rights held prior to Independence. Thus, in the original 13 Colony States, individuals or their grantees may own beds of navigable waters.

After Independence each of the 13 new States owned the beds of all the navigable waters formerly owned by the Crown. Under the “equal footing doctrine,” new States are entitled to the same degree of sovereignty and jurisdiction over all the territory within their borders, subject to the common law, as the original States. Accordingly, the beds of navigable waters were reserved for the future States; they were not explicitly granted by the Federal Government or the Constitution. See *infra* and sections 8-43 and 8-127.

**8-37.** Some courts have confused commerce jurisdiction cases with land title jurisdiction cases, both of which use the term “navigability,” but for different purposes. The Commerce Clause, U.S. Constitution, Article 1, Section 8, Clause 3, reserved to Congress the power to “regulate Commerce with foreign Nations, and among the several States, and with the Indian Tribes. . . .” Early in our national history the Commerce

Clause was held to mean that the United States had the authority to control navigation by means of dams, weirs, channeling, and other improvements without compensating owners of the uplands, so long as the work was entirely within the bed or within the boundaries of the river. Rivers and lakes where this Federal right exists are the “navigable waters of the United States” referred to in the *The Montello* and *The Daniel Ball* decisions. On “navigable” rivers it means that the Government need not pay for exercising this right—essentially providing a “rule of no compensation.”

In *Kaiser Aetna et al. v. United States*, 444 U.S. 164 (1979), is a case of the Commerce Clause. The Court acknowledged that though the formula for finding navigability under Admiralty Jurisdiction, i.e., *The Daniel Ball*, 77 U.S. 557 (1871), and *The Montello*, 87 U.S. 430 (1874), under the Property Clause, i.e., *Oklahoma v. Texas*, 258 U.S. 574 (1922), and *United States v. Utah*, 283 U.S. 64 (1931), and under the Commerce Clause, i.e., *United States v. Appalachian Electric Power*, 311 U.S. 377 (1940), and *Economy Light and Power Company v. United States*, 256 U.S. 113 (1921), seemed to be alike, in application it is very different. For example, under the Admiralty Jurisdiction or Commerce Clause, a water body may be improved to achieve navigability. Under the Property Clause, the issue is “ordinary condition at the time of statehood.”

**8-38.** Ownership of the bed of a navigable river or lake, whether held by an individual or the State, is not quite the same as ownership of a building lot in the city. The Federal Government has what is called a “dominant servitude” in all “navigable waters of the United States.” That servitude subjects all State and private ownership rights *within the riverbed* to the control of the Federal Government in the interest of navigation. The agencies that administer this servitude are generally the U.S. Army Corps of Engineers and the Federal Energy Regulatory Commission. The Corps’ administrative authority is confined to the beds of the rivers and lakes with limits defined by the OHWM or in the case of tidally influenced waters, the line of MHT.

The servitude is automatically exercised if a project on a navigable lake or river is related to the control or improvement of navigation. Just because part of the project is not useful for navigation does not void the servitude. A project may even destroy the navigability of other parts of the river if its purpose is in aid of navigation of major channels elsewhere.

**8-39.** Also separate from the Federal navigability servitude for land title purposes is the Federal servitude



governed by the Federal Water Pollution Control Act (86 Stat. 816; 43 U.S.C. 1344 and 1362) as amended. The Act refers to waters of the United States, which includes navigable waters (including tidal waters) and waters that affect navigable waters, such as interstate wetlands, nonnavigable waters with interstate or foreign connections, and tributaries of those waters, for jurisdiction over dredging and filling.

**8-40.** Ordinarily a conveyance document, usually a patent, issued by the BLM and its predecessor the GLO conveys title to the patentee down to the OHWM on navigable rivers and lakes. A riparian owner on one side of a meandered nonnavigable river is conveyed title to the medial line of the stream or to the center of a meandered nonnavigable lake. A patent to a littoral owner conveys title down to the line of MHT on tidal waters.

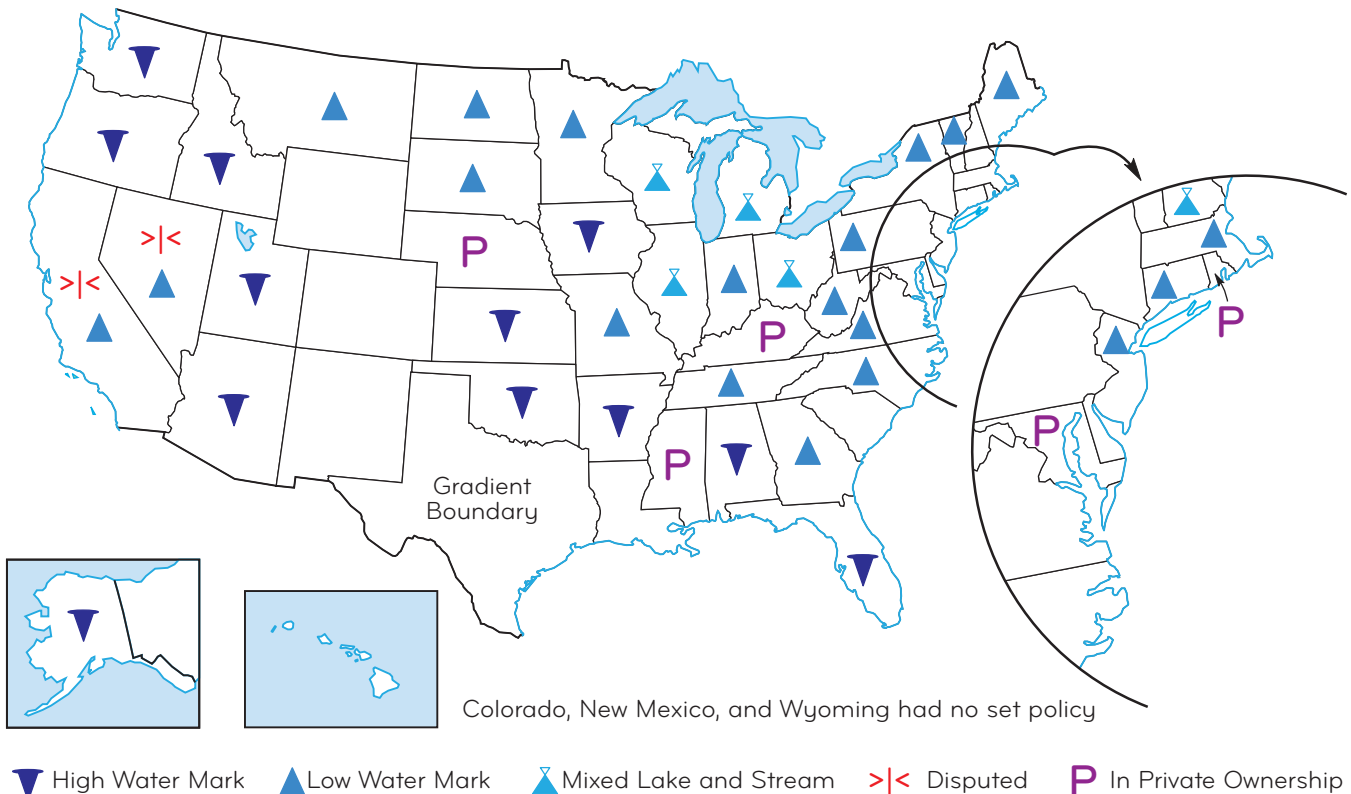
**8-41.** Each of the 50 States that came into the Union thus acquired ownership of the beds of the navigable waters within their boundaries, subject to the Federal navigation servitude. The lateral extent of that ownership was to the OHWM on each side of the inland water body. Because each State has the legislative power to dispose of or otherwise control ownership of these beds, and have treated them differently, there is some variety among the States as to current ownership, which may

affect how resurveys are conducted. Some States have granted the entire beds of their waters to the upland owners, disclaiming all ownership; some have granted the upland owners the banks down to the low water mark instead of the OHWM; some States kept the ownership of the beds of large lakes but granted the beds of the rivers to the upland owners (figure 8-4). Any claim to the bed must involve an examination for the possible effect of the law of the State in which it is located.

**8-42.** The title and rights of riparian owners in areas *below* the OHWM of inland navigable bodies of water are governed by State law rather than Federal law. The title and rights of littoral owners in areas *below* the line of MHT of tidelands are also governed by State law rather than Federal law (figure 8-5). Whether Federal or State law controls the ownership of land accreted to a riparian or littoral holding has been answered in a series of cases. See source of law considerations in sections 1-7 and 8-57.

**Application of the Submerged Lands Act on Lands Beneath Navigable Waters**

**8-43.** The 1953 *Submerged Lands Act* (SLA), 43 U.S.C. 1301 et seq., (1) essentially confirms States' equal footing rights to tidelands and submerged lands beneath



**Figure 8-4.** Inland navigable water claims by various States.

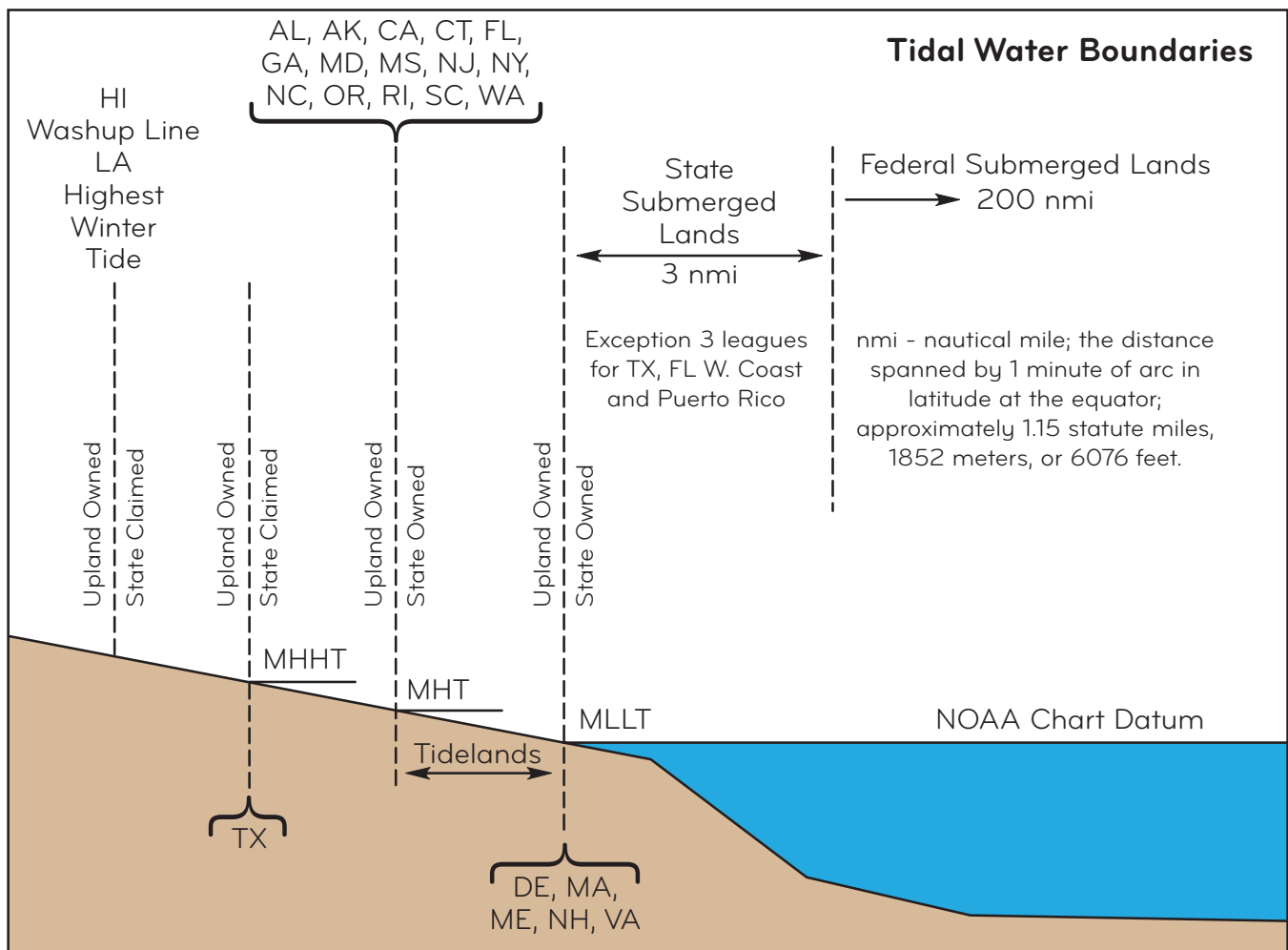


Figure 8-5. Tidal water claims by various States.

inland navigable waters, and (2) establishes States' title to submerged lands, including the tidelands, beneath a 3-mile belt of the territorial sea, which would otherwise be held by the United States (*United States v. Alaska*, 521 U.S. 1 (1997)).

The SLA mainly involved maritime boundaries but it also affected inland waters to some extent. For inland waters the Act defined the term "lands beneath navigable waters" as "all lands within the boundaries of each of the respective States which are covered by nontidal waters that were navigable under the laws of the United States at the time such State became a member of the Union, or acquired sovereignty over such lands and waters thereafter, up to the ordinary high water mark as heretofore or hereafter modified by accretion, erosion, and reliction . . . ."

The Act granted each State the ownership of all lands below the OHWM including the mineral estate. There were some exceptions: any lands ceded to the United States whose title was determined under State law;

all lands acquired by eminent domain, purchase, gift, cession, or acquired as a proprietary interest; all lands filled in, built up, or otherwise reclaimed by the United States for its own use; all lands withheld prior to statehood by the United States for the benefit of Indians; all structures and improvements constructed by the United States in the exercise of its navigational servitude; and all lands explicitly withheld by the United States prior to statehood.

**8-44.** Soil under navigable waters that lies between the OHWM and the low water mark in those States, such as Montana or Illinois, that have legislatively granted all upland owners portions of their river or lake bed, remain attached to any Federal upland as a gift, cession, relinquishment, or grant from the State. Where the Federal Government is such an upland owner, it is treated as any other upland owner when a State has bed ownership claims that differ from section 8-43.

**8-45.** The Secretary of the Interior has the authority and duty to segregate appropriated lands of all types from

the Federal interest lands. Therefore, nearly all surveys and resurveys enclosing or abutting the beds of navigable waters shall segregate those beds from the Federal interest lands. Placement of meander corners and the running of meander lines in front of the Federal interest lands is the method for creating the segregation line. The principal exception to this rule occurs along the boundary of some Federal Reservations and Indian Reservations where the beds or portions of the beds of navigable waters are included within the reservation boundary as described by an act of Congress, treaty, Executive order, or where specified in binding litigation. Where a pre-statehood grant of real property to an Indian tribe includes navigable waters within the grant boundaries and the grant is construed to include the submerged lands, title to the bed was withheld for the benefit of the tribe.

### Navigability Investigations

**8-46.** The question of navigability in law is a matter to be finally decided by the court with jurisdiction over the parcels and is based upon the facts and conditions in each case as of the date of Statehood. A frequently cited definition of navigability appears in *The Daniel Ball*, cited in sections 8-34 and 8-37. The same definition is applied to lakes. In *United States v. Holt State Bank*, 270 U.S. 49 (1926), the Supreme Court stated:

The rule long since approved by this court in applying the Constitution and laws of the United States is that streams or lakes which are navigable in fact must be regarded as navigable in law; that they are navigable in fact when they are used, or are susceptible of being used, in their natural and ordinary condition, as highways for commerce, over which trade and travel are or may be conducted in the customary modes of trade and travel on water; and further that navigability does not depend on the particular mode in which such use is or may be had—whether by steamboats, sailing vessels or flatboats—nor on an absence of occasional difficulties in navigation, but on the fact, if it be a fact, that the stream in its natural and ordinary condition affords a channel for useful commerce.

**8-47.** Artificial or natural changes *subsequent* to the date of Statehood do not bear on the subject of navigability for title purposes under the Property Clause. Such changes do affect navigability under the Commerce Clause or Admiralty Jurisdiction (U.S. Constitution, Article 3, Section 2, Clause 1). In *United States v. Appalachian Electric Power Co.*, 311 U.S. 377 (1940),

*reh'g denied*, 312 U.S. 712 (1941), the Supreme Court made the following clarification for purposes of the Commerce Clause:

“Natural and ordinary condition” refers to volume of water, the gradients and the regularity of the flow. A waterway, otherwise suitable for navigation, is not barred from that classification merely because artificial aids must make the highway suitable for use before commercial navigation may be undertaken.

**8-48.** The Secretary of the Interior has both the authority and the duty to consider and determine what lands are public lands of the United States (see 43 U.S.C. 2 and *State of Montana*, 11 IBLA 3 (1973)). Such authority and duty include an administrative determination of navigability of a river or lake to ascertain whether title to the land underlying the water body remains in the United States or whether title passed to a State upon its admission into the Union (*Western Aggregates, LLC.*, 169 IBLA 64, 76 (2006); *State of Montana*, 88 IBLA 382, 384 (1985)).

**8-49.** The Federal courts have final authority to determine navigability affecting public domain land. However, in the case of acquired lands, State court navigability determinations are controlling for these Federal interest lands. States have taken different approaches in determining which waters are navigable in their particular State for the purpose of ownership of the beds; from statutorily determining that all originally meandered waters are navigable, to statutorily declaring none of the waters in the State are navigable, to differing requirements for the elements of commerce, trade, and travel, to adoption of administratively determined navigability lists. If navigability is a factor in how a survey is to be conducted, consultation with the Solicitor’s Office is advisable.

**8-50.** Where the BLM is charged with segregating lands beneath navigable waters from Federal interest lands, an administrative determination of the navigability of the water body is required for preparation of special instructions. An investigation and finding of navigability for this purpose is within the BLM’s delegated survey authority. Ultimately, the matter is subject to judicial review.

Where such an investigation has been conducted, the results of the investigation and the reasons for its conclusions are properly reported in the field notes and the survey group file.

**8-51.** Often surveyed meander lines are the first navigability determination by the executive branch of the Government for a given body of water. The presence or absence of meanders would not affect an upland owner's rights if later legal decisions determined the water body navigable or nonnavigable.

**8-52.** The legal question of navigability is determined by the facts in any particular case and not from any action on the part of the surveyor. In *Oklahoma v. Texas*, 258 U.S. 574 (1922), the Supreme Court stated:

A legal inference of navigability does not arise from the action of surveyors in running meander lines along the banks of the river. Those officers are not clothed with the power to settle the questions of navigability.

The navigability or nonnavigability of a body of water may have been resolved by a jury upon consideration of the evidence and the opinion of competent witnesses. Courts have often taken judicial notice of the navigability or nonnavigability of streams and lakes.

Where such determinations have not been made, studies by the Corps of Engineers in connection with the improvement of rivers and harbors may be helpful in showing whether a river is navigable in fact. In questionable cases the necessary research as to navigability will be made and the facts noted in the special instructions.

**8-53.** The results of litigation in State and local courts do not ultimately determine navigability for Federal title purposes affecting public domain lands. Federal courts have the exclusive jurisdiction to make these judicial navigability determinations. However, the surveyor will generally rely on State and local court rulings because the Federal courts look to previous findings of navigability that have been based on reasonably thorough studies. Mere claims by State agencies that certain water bodies are navigable should be questioned as to the basis of such claims. Consultation with the appropriate State level agency is recommended as many States have made navigability studies. If the State agency's basis is reasonable, the determination should be accepted.

**8-54.** Any original survey or resurvey that includes a river or lake may require an investigation prior to issuing special instructions to determine if the river or lake is navigable for land title purposes. The investigation may be extremely brief as in the case of known major waterways of commerce or may require an on-the-ground inspection and historical study. Special instructions

for all surveys will identify any navigable water bodies involved in the survey and any limits of navigability such as the head of navigation. In questionable cases, absence proof otherwise, the presumption is that a water body is nonnavigable.

**8-55.** Items to be considered in a report on a navigability investigation include the following:

- (1) Physical description of the water body. Photographs of typical locations are useful when they are keyed to maps of the area;
- (2) A description of the water body at the date of statehood;
- (3) Historical evidence of use of the water body as a highway of commerce, over which trade and travel were conducted. Show actual uses, proposed uses that never materialized and the frequency of such uses;
- (4) The susceptibility of the water body for use as a highway of commerce, over which trade and travel could have been conducted, at statehood. More reasonable routes of travel around lakes or by other means of transport are pertinent;
- (5) Present day uses for recreation or commercial pursuits;
- (6) Comparison with similar water bodies that have been declared navigable or nonnavigable;
- (7) An interpretation of the various facts presented and the recommended weight to be applied to each;
- (8) An analysis of previous litigation, declarations of navigability by Attorneys General, State Legislatures or other governmental agencies, and
- (9) A definite opinion as to navigability or nonnavigability is required.

Litigation over the navigability of rivers provides an insight into the requirements of the law of this subject.

### **Navigability Investigations—Alaska**

**8-56.** For the purpose of lands selected by an Alaska Native, an Alaska Native Corporation, or the State of



Alaska pursuant to ANCSA, the Alaska Statehood Act, or ANILCA, “navigable” and “navigability” means navigable for the purpose of determining title to lands beneath navigable waters, as between the United States and the several States pursuant to the Submerged Lands Act of 1953 as amended (67 Stat. 29; 43 U.S.C. 1301 et. seq. and 1311 et seq.), section 6(m) of the Alaska Statehood Act, and the Alaska Submerged Lands Act of 1988 as amended (43 U.S.C. 1631(d)).

No agency or board of the Department other than the BLM has the authority to determine the navigability of a lake, river, or stream within an area selected by an Alaska Native or Alaska Native Corporation pursuant to ANCSA or ANILCA, unless a navigability determination was appealed on or before December 2, 1980 (43 U.S.C. 1631(c)(2)).

The execution of an interim conveyance or patent by the BLM that conveys an area of land selected by an Alaska Native or an Alaska Native Corporation, which includes, surrounds, or abuts a lake, river, or stream, or any portion thereof, shall be the final agency action with respect to a decision of the Secretary that such lake, river, or stream, is or is not navigable, unless appealed on or before December 2, 1980 (43 U.S.C. 1631(c)(1)).

## Source of Law Considerations

**8-57.** When State law and Federal law differ in application to an identical fact situation, a source of law situation arises. In practical matters, such as surveying, a source of law determination must be made that most probably would be the one chosen by the final court of competent jurisdiction. The surveyor is not expected to solve the problem entirely but must be able to recognize the problem and to prepare a technical analysis for review by legal counsel (section 1-7). However, in general, the following is true:

- (1) The scope of a grant or conveyance of Federal land is a question of Federal law.
- (2) The States are powerless to place any limitations or conditions on Federal grants.
- (3) Federal law shall govern the survey process for determination of the boundaries between States.
- (4) The boundaries of Indian property are to be determined according to Federal law.

(5) After Federal land has been granted or conveyed, State law is used to determine the ownership of the beds, and banks and shores of waterways unless there is a residual overriding Federal interest.

**8-58.** Items (1) and (2) are derived from *United States v. State of Oregon*, 295 U.S. 1 (1935). Oregon passed legislation to claim as State property all nonnavigable lake beds that were meandered by the official surveys. Specifically, Lake Malheur, Harney Lake and the channel connecting the two lakes were at issue. The lakes were included in a Federal withdrawal of public domain land for a Federal wildlife reservation.

They were large, shallow lakes and Lake Malheur was found to be dry at the time. A Special Master in the trial opined that the lakes were never used in commerce as highways or channels of navigation, from the date of statehood to the time of trial. The Supreme Court accepted the Master’s finding of nonnavigability. The decision of the Court held that the laws of the United States alone control the disposition of its lands. Also, that the construction of grants and conveyances by the United States is a Federal and not a State question. No State shall enforce laws that deprive the United States of its lands (see also *State of California ex rel. State Lands Commission v. United States*, 457 U.S. 273, at 282 and 287 (1982)).

Item (3) is derived from the principle that Federal law shall be used to determine State boundaries along rivers and lakes. (See 457 U.S., at 281.)

Item (4) is derived from *Wilson v. Omaha Indian Tribe*, 442 U.S. 653, 670 (1979): “Indian title is a matter of federal law and can be extinguished only with federal consent” because the trust relationship still exists on Indian owned lands. (See also 457 U.S., at 282.)

Item (5) is also derived from *Wilson* that states, “[A]bsent an overriding federal interest, the laws of the several States determine the ownership of the beds, and banks and shores of waterways” (442 U.S., at 669). An overriding interest might be an interstate boundary or an Indian boundary that would invoke Federal law. In *Oregon ex rel. State Land Board v. Corvallis Sand and Gravel Co.*, 429 U.S. 363 (1977) there was no such Federal interest but the Court held that Oregon State law was identical to Federal law in the matter. The State had “borrowed,” i.e., adopted, Federal law.



**8-59.** It may be determined as a matter of source of law that, although Federal law governs a given question, State law is sometimes borrowed and applied as the Federal rule for deciding a specific legal issue (457 U.S., at 283; 442 U.S., at 672). Controversies governed by Federal law do not inevitably require resort to uniform Federal rules. Whether to adopt State law or to fashion a nationwide Federal rule is a matter of judicial policy relevant to the nature of the specific governmental interests and to the effects upon them of applying State law (442 U.S., at 671; see also, *United States v. Hess*, 348 F.3d 1237, 1243 (10<sup>th</sup> Cir. 2003)).

**8-60.** Three factors in determining whether State law may be borrowed as the Federal rule of decision have been enunciated by the courts:

- (1) Is there a need for a nationally uniform body of law to apply in situations comparable to the case?
- (2) Would application of State law frustrate Federal policy or functions?
- (3) What is the impact a Federal rule might have on existing relationships under State law (442 U.S., at 673)?

A rule of decision is a settled principle based on precedents in previous decisions. It is considered a guide or a norm in a court's decision.

## Opposite Banks Delimitations

**8-61.** It is sometimes necessary to define a line representing the limits of ownership between opposite banks, for instance, in showing the limits of an Indian Reservation or a National Park boundary. In navigable waters such a line might be either the deepest navigable channel (thalweg) or a medial line. This is occasionally important in cases of reliction to public land fronting a navigable body of water or avulsion and subsequent division of an abandoned channel. In nonnavigable waters the common property line is usually the medial line, but may be the deepest channel (thread), especially of an abandoned channel.

### Medial and Median Lines

**8-62.** The median line is the mathematical mean between the controlling points and lines on the opposite bank meander courses or informative traverse. The

derived median line is comprised of straight line and curved segments halfway between the controlling lines and points on either bank. The curves are parabolas.

The medial line is simply the middle as measured half way at all points. The medial line will also fall between the opposite bank meander courses or informative traverse. The medial line also establishes a continuous line, formed by a series of intersecting straight line segments or a combination of straight line and curved (circular) line segments, every point of which is equidistant from the nearest point on the opposite shores, to closely approximate the true median. The medial line is often used in determining the boundary between opposite upland owners in abandoned channels.

Median and portions of medial lines are calculated from the meander lines or informative traverses conducted along the banks of the water body (figures 8-6 through 8-11). These traverses provide a series of point-point,

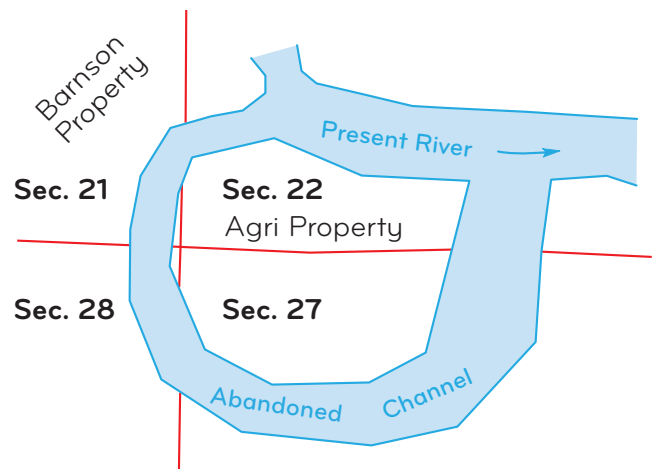


Figure 8-6. An abandoned channel requiring medial line determination.

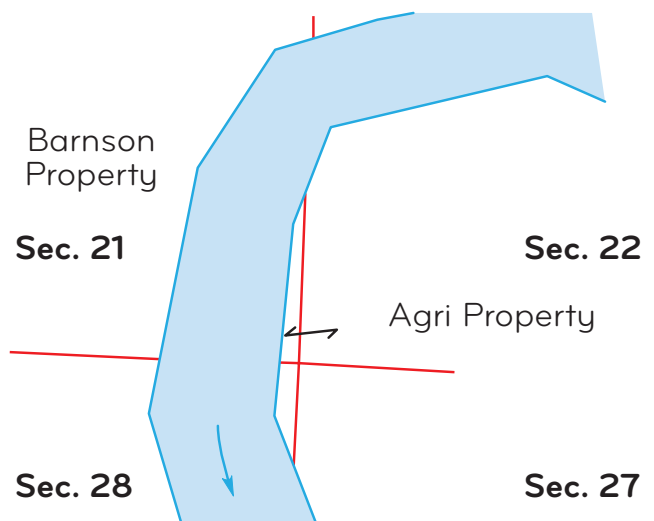


Figure 8-7. An enlarged portion of the abandoned channel.

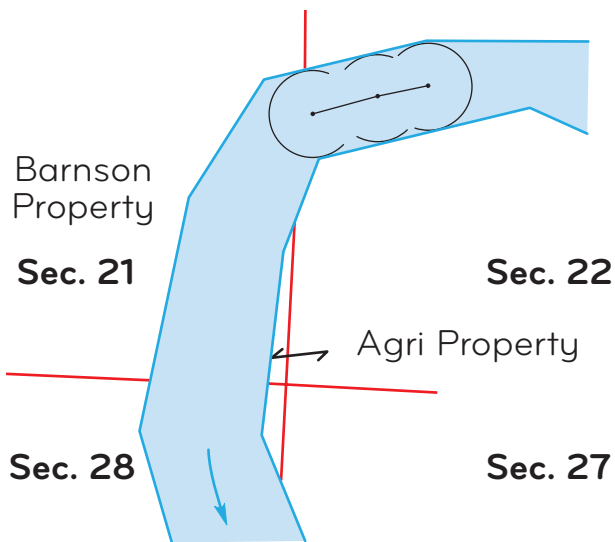


Figure 8-8. The center point of a series of inscribed circles on a straight reach.

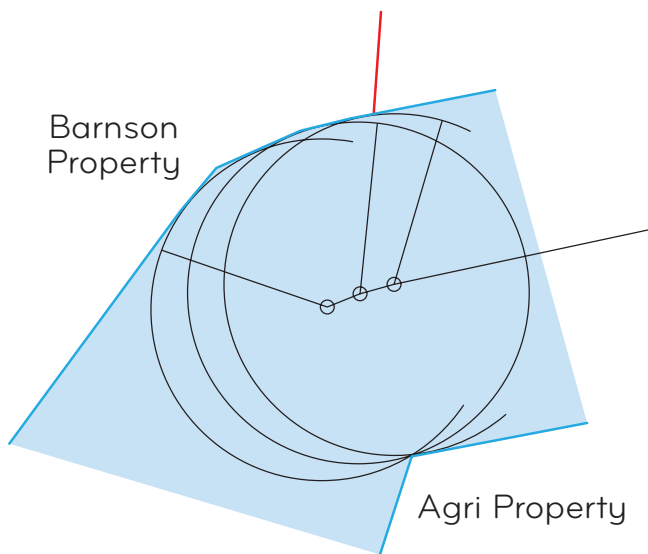


Figure 8-9. Inscribed circles from a salient point.

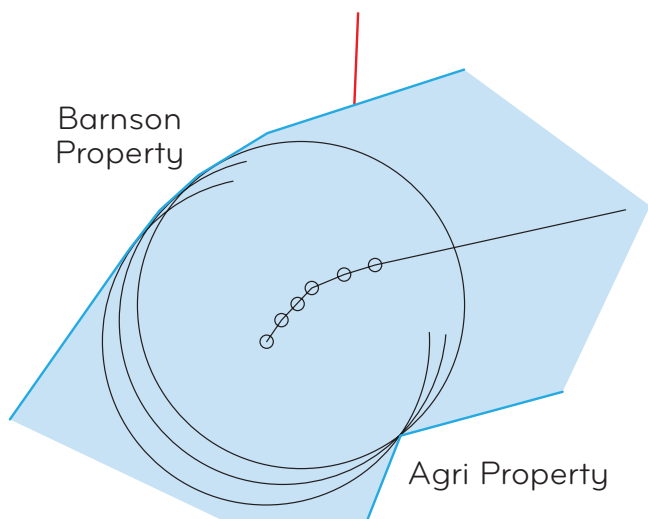


Figure 8-10. The progression of the medial line.

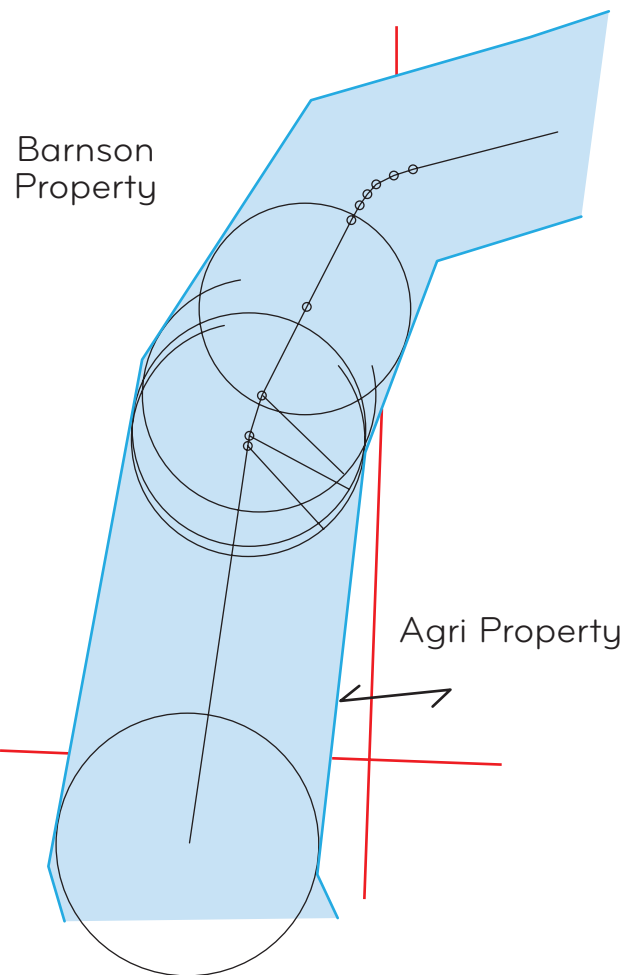


Figure 8-11. The medial line continues on the straight reach in this fashion to the end of the abandoned channel.

point-line, and line-line conditions that control the location of the median or medial line. The easiest way to visualize the location of the median or medial line is to imagine a circle that expands or contracts while remaining tangent with the meanders on either side of the water body as the circle moves along the stream. The radius point of this expanding and contracting circle is tracing the median line.

**8-63.** For reporting purposes, that portion of the median line computations resulting in parabolic curves are replaced with straight line segments, by extending the tangents, or with circular curves. The modified result is also defined as a medial line. In which event a statement should be made in the field notes that:

A median line was computed between the meanders of the left and right banks of an abandoned channel of the \_\_\_\_\_ River in section \_\_\_\_\_. The computation produced several parabolic curves. Elements of the curve

descriptions were eliminated to produce straight line segments, with no significant change in the true position of the median line. No effect on acreage or bona fide rights was detectable. The resulting approximation is defined as the medial line.

**8-64.** When State law governs, in those States that require the medial line to be determined between the low water marks instead of the OHWMs or require the thread of the stream to be determined, special instructions must comply with those requirements to protect the alienated lands on the opposite banks.

**8-65.** The median and medial lines of a water body are necessarily ambulatory lines when their location is based on the lines of the OHWMs that are themselves ambulatory. The median or medial line may be a fixed line where the governing bank lines are fixed, as in an avulsed area.

**8-66.** Normally the present ordinary high or low water mark is used to establish a median or medial line. Occasionally a median or medial line is to be established between bank lines as they existed at some time other than the present. For example, a medial line may be established between bank lines determined by historical aerial photography to define a former or historical boundary position. Where the best evidence of former bank line is a reliable survey, the medial line is then shown as of the date of that survey. Where mining or other earthwork has completely obliterated historical bank lines and no other reliable evidence showing the predestruction conditions is available, the original survey meander lines may serve as the best available evidence of the bank location(s). Of primary importance is the use of the latest reliable bank information, in order to satisfy equitable considerations.

**8-67.** Because the lines of the OHWM are rarely straight for any distance, the OHWM is approximated by a traverse called a meander line or, when fronting alienated lands, an informative traverse. Where a median line or an unusually precise medial line is required, use special care in approximating the OHWM. This is simply achieved by careful attention to the indicators of the OHWM position. (See section 3-168 and following sections for such indicators.)

**8-68.** By definition a point-line condition results in a parabola. Determining area under a parabola or describing this curve is difficult. Practice is to substitute a circular curve that best fits the parabolic curve. Another

option is to remove the parabola entirely, when they are short, and extend the straight line segments on either side of the parabola to intersection; or construct sub-chords along the curve.

In addition, depending upon the configurations of the meander lines or informative traverses, the resultant median or medial line may contain an excessive number of courses. It is expected that a smoothing process will remove sufficient line segments to retain the general configuration of the median or medial line without creating an overly detailed number of courses to return in the field notes or plats.

**8-69.** The median line process can involve substantial calculations: fortunately the process has been automated. The medial line may also be determined graphically without computation on a large, carefully scaled diagram based on aerial photography or maps.

Where opposite bank lines are relatively long and straight, a line called a bisector in geometry defines the medial line and is also a precise median line. But where bank lines are relatively short and the river is relatively wide or where bends in the river occur, special methods may need to be employed to establish the median or medial line. This becomes apparent when the computational or graphically derived median or medial lines are overly complex or inequitably reduce an upland parcel's interest in the bed.

Because the precision to which the OHWM can be determined on each bank is usually not better than 5 links in horizontal position, there is usually no reason to be more precise in reporting a median or medial line calculated from those bank lines. Accordingly, unless special conditions such as a court order are present, the curved portion of the medial line may be approximated by one or more straight courses.<sup>1</sup>

With the advent of computer programs that can quickly and precisely compute a median line, it may actually involve extra work to degrade the median line (figure 8-12). Accordingly, the special instructions will note

<sup>1</sup> The salient point method is another possible method used for determining median or medial lines. Rather than using the meander line traversed, prominent points along both shores are used. This method is normally reserved for use with sea boundaries. As defined in the United Nations' "Convention on the Territorial Sea and the Contiguous Zone," held in Geneva in 1958, a median line is a "line every point of which is equidistant from the nearest points on the baseline." In that case, the "baseline" is the line of mean low water. The definition may be made applicable to inland submerged lands boundaries by substituting "line of ordinary high water" for "baseline."

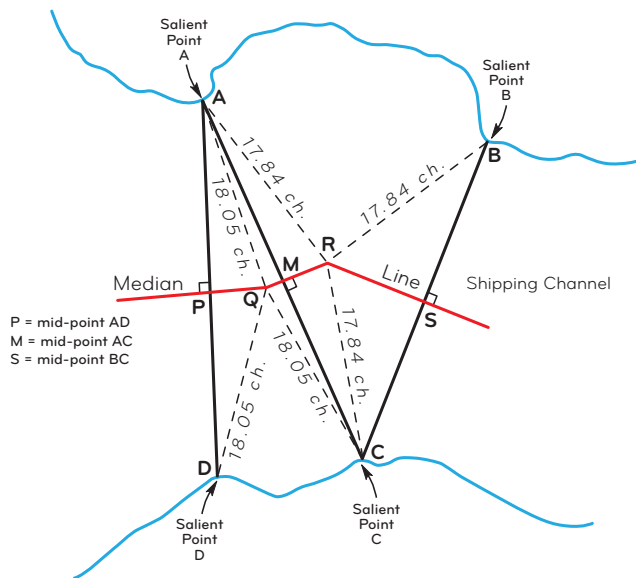


Figure 8-12. Definition of a median line by salient points.

to what precision the median or medial line must be reported, taking into account whether the water course is still active or an abandoned channel (fixed and limiting boundary), whether a Mineral Leasing Act lease is involved, and whether the resulting determination meets limits of closure and positional tolerances requirements.

### Thalweg

**8-70.** The thalweg, or talweg, is an ambulatory line often used to designate the division line between opposite nations or political subdivisions along navigable rivers and lakes. The word comes from the German word for “valley way.” The thalweg follows the line of usual navigation in a river, not necessarily the deepest channel, used by boats of maximum tonnage on their downstream passage. The line of deepest water often occurs close to one bank. The geometry of the thalweg can be determined by observation of river traffic or from charts used by river pilots.

### Thread

**8-71.** The thread follows the line of deepest water. The thread is ordinarily an ambulatory line often used to designate the division line between opposite upland owners along nonnavigable rivers and lakes. In cases when access to water is the primary issue and the thread occurs close to one bank, the courts have invoked equity and rejected the medial line as the division and adopted the thread. This low water approach recognizes, for example, the access to water by cattle. The geometry of

the thread can be determined by vertical measurement of the bed of the water body. The thread can become a fixed boundary line by an avulsive action.

Most commonly, the thread is found in abandoned channels, especially between islands and the adjoining upland where the channel has rellected due to the upstream opening of the channel closing off by accretions. In these instances it is appropriate to walk the lowest portion of the rellected channel while selecting angle points for this line.

**8-72.** Where Federal law is controlling, and the “middle” is specified, the medial line is presumed to be the boundary. Where the line of navigation was intended the medial line is the boundary unless it can be proven that the vessels that navigate those parts keep their course habitually along some channel different from the medial. Where the water body is nonnavigable, the medial line is the boundary unless it can be proven that access to the water was the intent, then the thread is used. These determinations by the surveyor must be documented thoroughly and in many cases must be as extensive as navigability investigations. Ultimately the decision is subject to further administrative review and to judicial review.

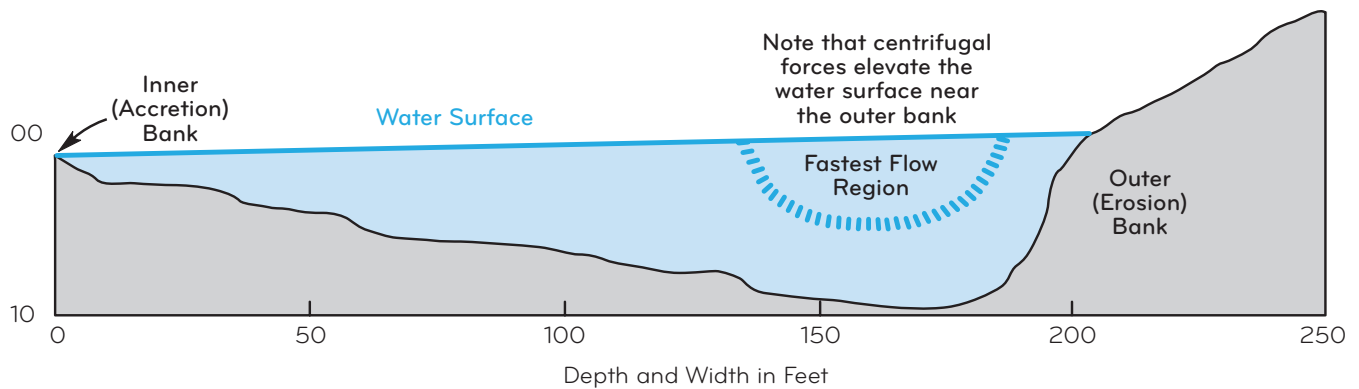
### Special Boundary Lines

**8-73.** The decision on whether the thalweg, thread, or the medial line is the appropriate dividing line is determined by the language in the act of Congress, treaty, Executive order, or withdrawal for each boundary involved. This affects State boundaries, Indian reservations and special designated areas described outside the legal subdivision system of the rectangular surveys, where the surveyed lines follow a river or a lake.

See the Chapter VIII Notes for case studies on navigability.

### Water Body Movements

**8-74.** A river flowing through its own sediments is called an alluvial river. Alluvial rivers by their nature move around over time by the process of erosion of one bank and deposition on the other bank. The entire process is called meandering. The word meander comes from the Meander River (now Menderes River) in Asia Minor that wanders back and forth across its floodplain. For more details on how physical changes occur in a



**Figure 8-13.** Cross section of a river at a bend.

river, see *A Laboratory Study of the Meandering of Alluvial Rivers*, by Captain J.F. Friedkin, U.S. Corps of Engineers, 1945.

**8-75.** An alluvial river will not ordinarily flow in a straight line even over short distances. As curves in the river alignment develop, the faster currents in the flow move toward the outside of the curve (figure 8-13).

These faster currents erode the soil at the bottom of the outside of the bend causing the surface soil to fall into the river where it disintegrates. The soil removed is deposited, mainly on the opposite (inside) bank of the next curve downstream.

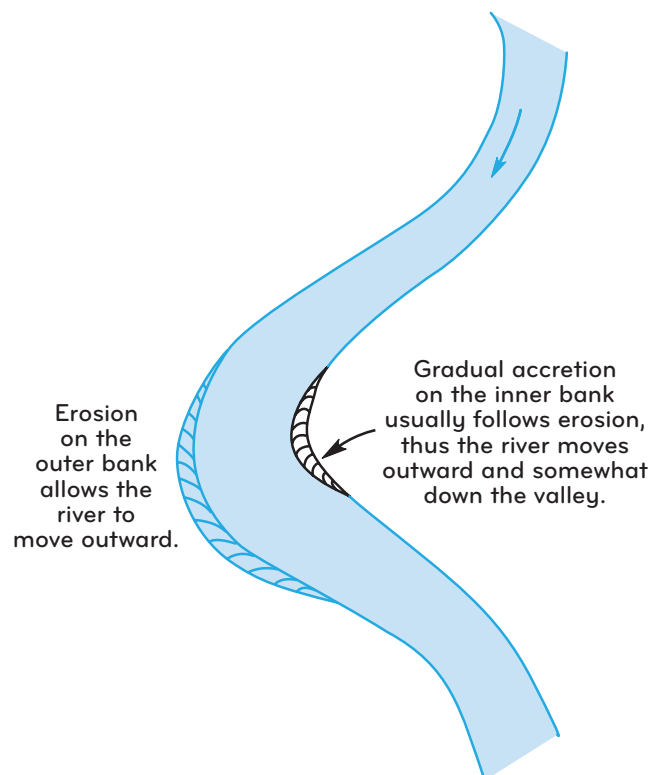
Rivers meander by reason of the continued erosion and accretion of alluvial soil on the bends. The cumulative effect of meandering is the movement of the river's course in a down-the-valley direction as well as outward from the axis of the bends (figure 8-14).

**8-76.** The process of deposition is called "accretion." Accretion is defined as the grain-by-grain deposition of soil along the bank of a river. The term is applied both to the gradual and imperceptible deposition of material along the bank of a body of water and to the lands formed by this process. It is usually accompanied on the opposite side of the stream by the reverse process, erosion. Both accretion and erosion can affect land boundaries, including the boundaries of Federal interest lands.

**8-77.** A river that has a relatively steep gradient and carries a heavy sediment load may be classed as a braided stream. The beds of braided streams usually consist of many small channels that move around between island-like soils formations that have no permanent upland vegetation. These channels fill up during heavy sediment transport and, thus, become clogged during flow. As these channels clog the flow will jump over and find

a nearby route within the stream bed. Thus the entire bed consists of these ephemeral channels.

**8-78.** During periods of high runoff in a river the water surface rises and at the same time larger and larger sediment particles are picked up from the riverbed due to increased velocity of flow. Smaller particles are swept up into the flow but larger particles—even boulders are bounced or rolled along the bottom. In effect the river bottom is lower in elevation during high flows in a process called bed scour. On larger rivers such as the Missouri or Colorado River there may be as much as 2 feet of bed scour to accompany 1 foot of rise in the water surface.



**Figure 8-14.** As a result of erosion on the outer bank and accretion on the inner bank, the river moves outward and down the valley.

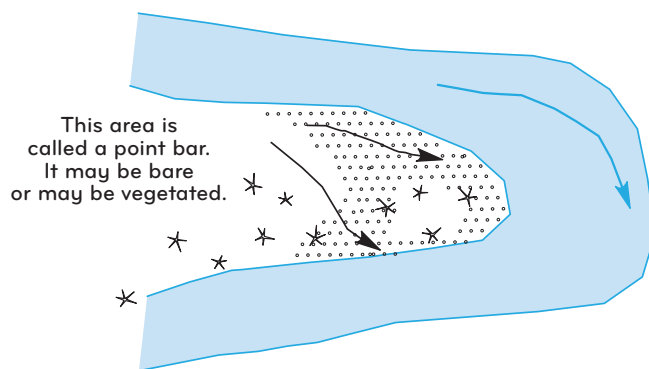


**8-79.** A bar in a river is a low formation of soil that has risen from the bed by the action of the river. Bars may be identified as gravel bars or sand bars according to the material forming them. A point bar is the material added to the inside of a meander bend (figure 8-15). The formation is first deposited below the OHWM but may continue to add material during high flows above the OHWM. A chute channel is a breach across a point bar that occurs when high rates of flow erode a “short cut.”

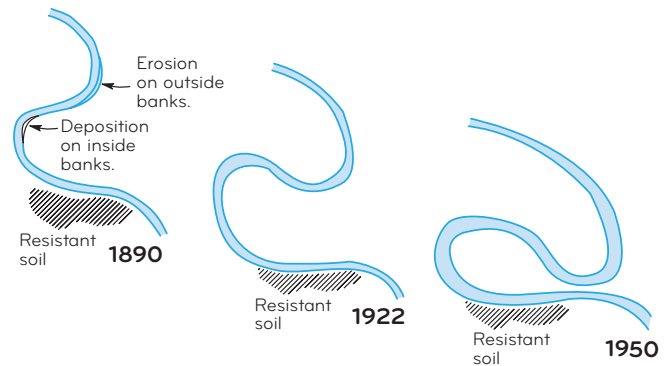
**8-80.** As seen from the air, the older, mature rivers will have meanders that are very pronounced. If a river that is in the process of moving down valley encounters an erosion resistant area the meander bends begin to tighten up. Eventually the tightening process causes the river to break through into the next meander below. The process is described as a classical avulsion.

**8-81.** An “avulsion” is the sudden and perceptible change in a channel of a boundary stream with a new channel and remaining “fast” land between, or a comparable change in some other body of water forming a boundary owing to natural causes or from the result of human activity (figures 8-16 and 8-17). Water may continue to flow in both channels with resulting boundary movement but the process is complete when the flow in the old channel becomes stagnant under ordinary flow conditions of the river.

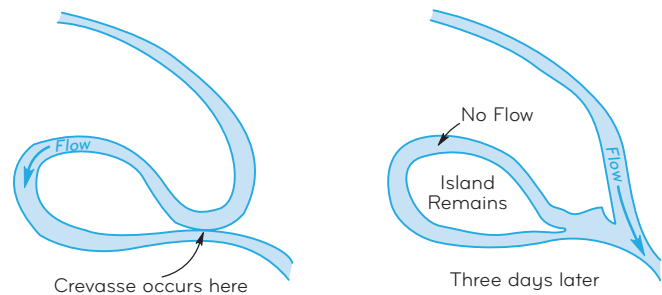
**8-82.** Changes in the shoreline due to an earthquake can be an avulsion. Where abrupt tectonic changes in the earth’s crust that occurred after statehood but before survey have elevated the mainland relative to the present sea level, the State may own the area between the two sea level positions. The survey line will be run as a fixed and limiting boundary that closely approximates the former coastal boundary. Where the tectonic change has abruptly depressed the mainland the present tidewater



**Figure 8-15.** A point bar is an accretion on the inside of a bend in a river. Over time, a point bar can become vegetated and classifiable as upland.



**Figure 8-16.** The beginnings of an avulsion. River meanders move outward and downstream unless they are impeded by a solid object such as extremely resistant soil or rock.



**Figure 8-17.** As the meander loops tighten, the narrow neck finally breaks through and the eroding waters tear out the “shortcut.”

boundary is meandered without consideration of the tectonic change. An abrupt tectonic change is considered the equivalent of an avulsion.

**8-83.** Human-made channelization and rechannelization after the date of grant or statehood is generally treated as an avulsion.

**8-84.** “Reliction” comes from the Latin word for relic. It is the long continued and gradual uncovering of land caused by the recession of a body of water. Relicted land is treated in the same manner as accreted land insofar as its survey is concerned.

**8-85.** “Emergence” is the process of uncovering of the bed of a water body, the opposite from submergence. It is synonymous with the term reliction. Emergence is generally accomplished by changes in the OHWM of the water body or the uplift of the upland. This is different from “accretion,” which is the gradual forming of upland caused by the deposition of fine material on the bed of a water body.

**8-86.** “Submergence” is the process of covering of upland with rising water, the opposite from emergence. This change usually is accompanied by changes in the

OHWB of the water body or the depression of the upland. This is different from “erosion,” which is the eroding of upland by water action, causing the area to be covered with water.

**8-87.** “Reemergence” is the process by which land is submerged by water, followed by the reappearance of the same soil by the process of (1) withdrawal of water or (2) elevation of terrain, and not by accretion. The first change is accompanied by changes in the OHWM of the water body. The second change is not accompanied by changes in the OHWM of the water body. Reemergence is not the formation of a new feature in the same location of a previous feature; that is the process of accretion, to either the island or mainland, or to the bed of the water body. Both of these processes have been called “reappearance.”

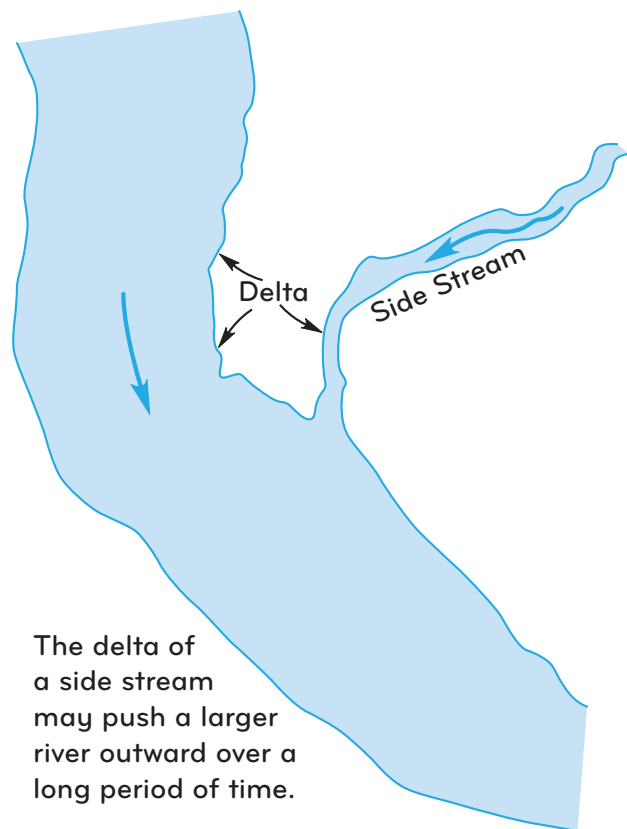
Where the root cause of emergence is a very slow elevation of terrain, as in isostatic rebound of the earth’s crust in arctic regions due to melting glaciers and the removal of that weight, the boundaries may move as the OHWM moves, the change is generally treated as accretion. Where the root cause of the emergence is sudden uplift of terrain accompanied by earthquake, or a channel straightening project, the change is generally treated as an avulsive.

**8-88.** Where a sediment laden side stream enters a larger river a delta may form on the bed of the larger river, which can push the larger river away from the delta (figure 8-18). Accretions occur as a result of flowing water depositing sediments along the bank and thus change the shoreline of the river and the boundaries formed by that shoreline.

**8-89.** A river is at flood stage when the first runoff overtops a riverbank and begins to flow across the flood plain. At the time when a flood begins to recede, soil particles being washed across the banks of the river will begin to drop out of suspension. The larger particles drop out first, which places them near the top of the riverbank. In consequence, many such flood events will produce a low “natural levee” along both banks of most alluvial streams. Beyond the natural levee is the flood plain, called a “backswamp” when the flood plain is water logged (figures 8-19 and 8-20). Natural levees provide a good indicator of the OHWM on alluvial streams.

### Legal Effect of Avulsions Under Federal Rules

**8-90.** As a general rule an avulsion legally fixes land boundaries formed by riverbanks at position prior to the



The delta of a side stream may push a larger river outward over a long period of time.

Figure 8-18. Delta formation in a larger river.

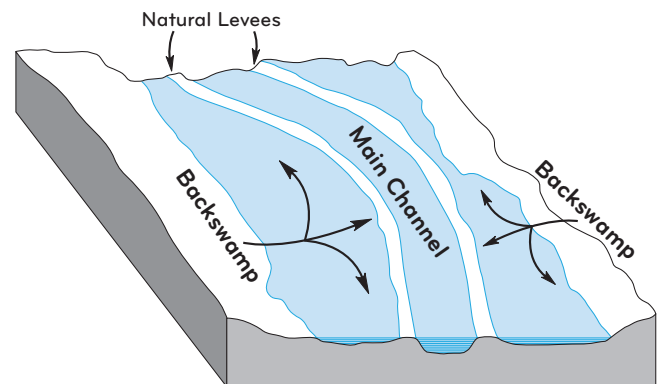


Figure 8-19. An oblique view of a river showing natural levees and backswamps. Natural levees may remain dry during minor floods.

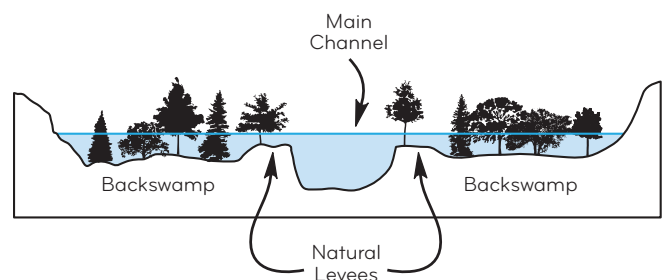


Figure 8-20. Cross section of natural levees during a major flood. The main channel carries most of the flow. As sediment-laden flow escapes into the backswamp, the heavier particles drop on the natural levee, increasing its height.

avulsion, within the limits of an avulsion. The rules vary between Federal holdings and some State holdings and there are a few other exceptions outlined below.

**8-91.** Avulsions within a survey area that have occurred before original survey and before statehood are meaningless as to boundaries, in that no rights or boundaries had yet been created. However, an avulsion that occurred after statehood but before survey could result in a possible claim of navigable bed ownership by the State involved. Such a situation occurred on the Colorado River shortly after California's statehood in 1850 but California never claimed the avulsed bed so the situation was ignored in an appellate decision affecting the area (*United States v. Byrne*, 279 F.3d 677 (9<sup>th</sup> Cir. 2002), *as amended on denial of reh'g*, 291 F.3d 1056, *cert. denied*, *Aria et al. v. United States*, 537 U.S. 1088 (2002)).

**8-92.** Avulsions that occurred after the original survey of public lands but before entry, claim, or issuance of patents in the township are important because no patents should be issued that include the avulsed areas. If the bed or the lots and aliquot parts in the township affected by the avulsion are Federal lands, the survey will be amended to reflect the new river positions.

**8-93.** In the case of *Nebraska v. Iowa*, 143 U.S. 359 (1892), the Supreme Court held:

It is settled law, that when grants of land border on running water, and the banks are changed by the gradual process known as accretion, the riparian owner's boundary line still remains the stream, although, during the years, by this accretion, the actual area of his possessions may vary.

It is equally well settled, that where a stream, which is a boundary, from any cause suddenly abandons its old and seeks a new bed, such change of channel works no change of boundary; and that the boundary remains as it was, in the center of the old channel, although no water may be flowing therein. This sudden and rapid change of channel is termed, in the law, avulsion.

**8-94.** Listed here are several summary statements about avulsions relative to Federal interest land that are important for surveyors to understand:

(1) Avulsion is defined as a river suddenly abandoning its old bed and taking a new bed. Such a geometry of rivers implies that there was an old left and right bank and in the same reach

of river there is a new left and right bank, while leaving positively identified upland in place between the old and new channels.

(2) The avulsion may have occurred from any cause—this would include human-made alterations of the riverbed, e.g., channelization or rechannelization.

(3) Prior to the avulsion, the stream formed the boundary. The boundary remains fixed at its last previous location just prior to the avulsion and does not follow the water course to its new location.

(4) If the boundary was at the middle of the river, it remains fixed at that location even if there is no flowing water. It will be logically inferred that if the boundary was the thalweg, the last thalweg would be the fixed boundary even if there is no flowing water. Also, if the preavulsion boundary was the thread of the river, the boundary remains at the abandoned thread in the avulsed reach.

(5) An avulsion is complete when the water in the old channel becomes stagnant under ordinary flow conditions of the river (*Arkansas v. Tennessee*, 246 U.S. 158 (1918)). This means that erosion and accretion may occur in the former channel during the time when the river is adjusting to the avulsion. However, when the flow ceases in the old channel, the boundary is fixed as a matter of law recognizing the practicality of the new conditions as there are no longer erosive or accretive actions at work.

(6) If an avulsed river resumes its former channel, the boundary is no longer fixed and accretion and erosion once again can move the boundary (*dicta in Nebraska v. Iowa*, above).

(7) In a braided stream that is bare of permanent upland vegetation between braid channels, changes of channel that occur in the bed of the river between the outer braids, are not avulsions (see *Peterson v. Morton*, 465 F.Supp. 986 (D.Nev. 1979), *remanded by, vacated by, in part on other grounds, Peterson v. Watt*, 666 F.2d 361 (9<sup>th</sup> Cir. Nev. 1982) described below).

(8) Where a State owns the bed of a river that has avulsed, the State remains the owner of the old abandoned channel but does not own the

newly created bed. Landowners, including the United States, whose property was submerged or washed away by the new course of the river generally have no recourse unless they were physically able to move the river back into its old channel soon after the event.

(9) When Federal common law is the source of law, rapid erosion does not normally constitute an avulsion (*Nebraska v. Iowa*, 143 U.S. 359 (1892)).

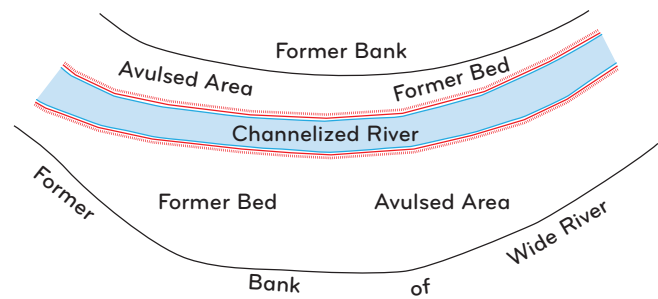
(10) Channelization, the artificial filling in along the bank of a navigable river or the narrowing of the riverbed, leaving former riverbed exposed as upland, is an avulsive change that fixes the boundaries of the riverbed property at the location of the OHWMs of the river immediately before the project (figure 8-21).

(11) Rechannelization, the removal of a navigable river from its former channel and relocating it to an artificially constructed channel, leaving the former bed exposed as upland, is an avulsive change fixing the boundaries of the riverbed property by the location of the OHWMs of the river immediately before the relocation of the river (*Puyallup Indian Tribe v. Port of Tacoma*, 717 F.2d 1251 (9<sup>th</sup> Cir. 1983), *reh'g denied*, 466 U.S. 954 (1984)).

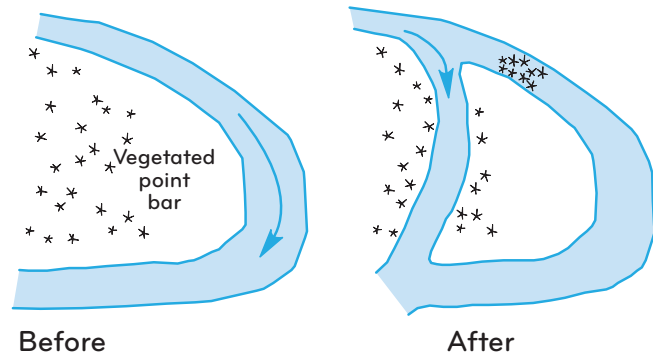
**8-95.** A classical avulsion has been described above. Other types of avulsions are described as follows:

(1) Point bar avulsion occurs when a chute channel cutting through a vegetated point bar (upland) enlarges by erosion such that the entire river flows through the short cut and the former river bend is an abandoned channel (figure 8-22).

(2) Backswamp avulsion occurs when flood waters break through a natural or human-made levee upstream from a large river bend (figure 8-23). During flood the flow through the levee break travels downstream along the backswamp (the area beyond the natural levee) becoming deeper as it progresses downstream. When the depth exceeds the natural levee, the water ponded in the backswamp breaks through the downstream natural levee in the reverse direction, i.e. back into the main channel. Because the length of channel through the backswamp is shorter than the old main channel, an avulsion

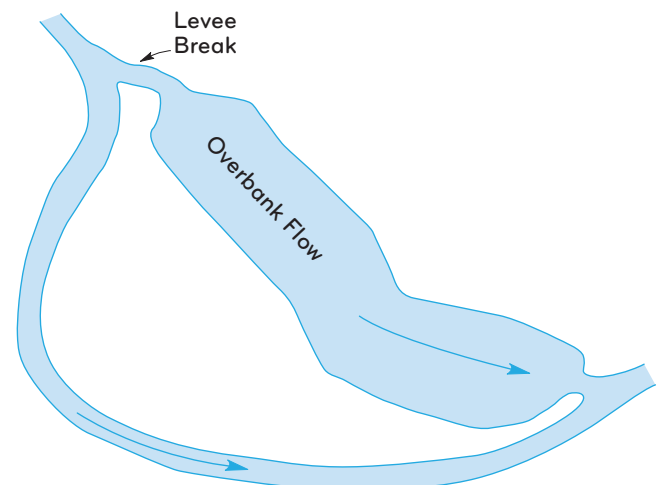


**Figure 8-21.** Channelization has narrowed a wide, shallow river to improve navigation.



Note: If the point bar had not been vegetated, there would be no avulsion as a surveying matter.

**Figure 8-22.** During high water events, large amounts of water cut across point bars and can scour out a new channel.



**Figure 8-23.** Overflow from a levee break spreads out over the backswamp at the beginning of avulsion.

may occur. Hydraulic conditions required for avulsion to occur depend on the flow efficiency of the backswamp channel compared to the old main channel. The avulsion occurs when the river abandons the old main channel when ordinary flow levels resume.



(3) Ice jam avulsion occurs when river ice accumulates and raises a dam high enough so that water may flow around a new route to a point downstream of the ice dam (figure 8-24). If this temporary channel erodes into a more efficient floodway, the river will abandon the former main channel.

(4) Levee cutoff avulsion, also called a Yazoo avulsion after the Yazoo River in Mississippi, occurs when a tributary river avulses into the backswamp of a much larger river (figure 8-25). The Yazoo River formerly entered the Mississippi

River several miles above Vicksburg. At a time when the Mississippi was at normal flow and the Yazoo was in flood, the Yazoo broke through its southern natural levee upstream from its mouth. Because the backswamp of the Mississippi River was miles wide, the levee breakthrough traveled down the Mississippi backswamp unimpeded for miles before it reentered the Mississippi at Vicksburg. That shortcut through its natural levee became the main channel, abandoning its former mouth upstream.

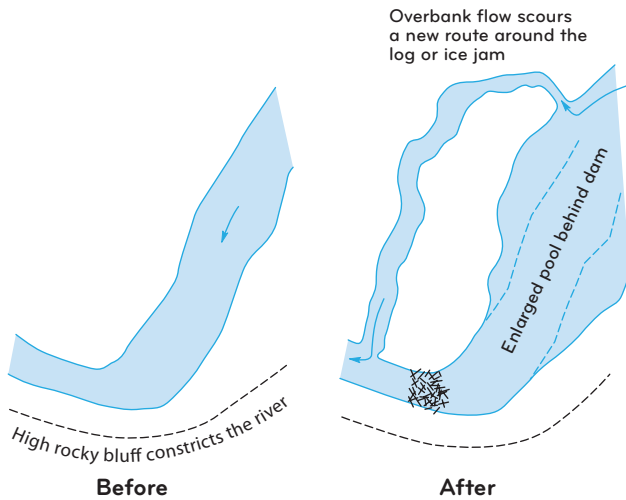
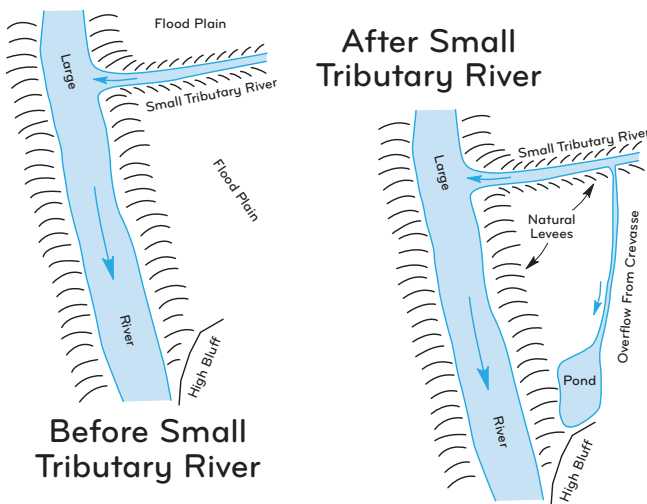


Figure 8-24. Ice jams or log jams can cause avulsions if the overflow scours a viable channel.



Note: If the pond continues to fill such that it can break through the large river's levee, the avulsion may continue to completion.

Figure 8-25. Levee cutoff avulsion reroutes a tributary channel.

**8-96.** Litigation sometimes ensues many years after an avulsion occurred. It is sometimes difficult to determine with certainty exactly where the river was at the time the avulsion was complete. One of the more reliable tools for age-dating terrain is to use tree-core data. It can readily be shown that a newly cored tree has been in place for the number of years represented by the annual growth rings. Historical aerial photographs, surveys and reliable maps are also useful for such determinations. Other than those items, eyewitness testimony and testimony by experts on river mechanics or sedimentation are of assistance. Avulsive changes to a river are dangerous and can cause expensive loss of property. As such, local citizens will normally remember the event and can point out where the river used to run and where it began and ended.

**8-97.** An avulsive change cannot be assumed to have occurred without positive evidence. Positive evidence is direct proof of the facts establishing that an avulsion has occurred and does not arise from any presumption. When no such showing can be made, it must be presumed that the changes have been caused by erosion and accretion.

It is important that positive evidence is found to show that an avulsion has occurred, and a detailed description of that evidence must appear in an investigation report if a survey does not follow, or in the group file and in the field notes if a survey is completed. Positive evidence may be in the form of historical aerial photography, local newspaper articles, witness testimony, or other evidence of the factual circumstances.

**8-98.** A change in course of a stream is clearly avulsive when the land between the old and new channels remains substantially as it was. The unaltered condition of the land may be indisputably shown by the continued existence of improvements in place or of timber, undergrowth, and other vegetation. A study of historic documents, especially maps and aerial photographs, will



often help in determining what process has taken place. As a general rule, the abandoned channel is easily identifiable where an avulsive action has occurred.

**8-99.** Another type of evidence that may be used is related to physical factors of the river. If the new flow alignment of a river is shorter in length than the old flow alignment, the change is avulsive. This test is based on river flow hydraulics. If, during a flood, a river spills over into a new route, the entire river will not assume the new route after the flood unless the velocity of flow is greater than the velocity in the old route. Because the hydraulic head available is the same for both routes, the velocity in the shortest route will be higher and will be the stream's new preferred route. This is related to Manning's formula for the velocity of a stream. In litigation, this material should be presented by an expert versed in hydraulics.

**8-100.** The bed of a new channel resulting from avulsion continues to belong to the owner of the land encroached upon. The bed of the former channel continues to belong to the riparian owners if the stream is nonnavigable. Ownership of the abandoned bed of a navigable stream is governed by State law, unless there was an explicit reservation of the bed by the Federal Government prior to statehood.

**8-101.** When the change in a water course is avulsive and the boundaries remain unchanged, any subsequent movement of the avulsive (new) channel, whether caused by accretion, erosion, or by another avulsive action, does not change property lines.

**8-102.** Avulsive changes to lakes are rare. A lake may be suddenly drained when a river erodes its way into the bed of the lake, or when a lake formed by an active glacier blocking a side stream suddenly undermines the glacier, allowing the lake to drain, or conceivably, due to an earthquake. Where land is inundated due to damming or other such direct human-made improvements, the boundary remains fixed at its last previous location just prior to the avulsion. Lakes that dry up due to climatic changes or other more general human influence are not avulsed—the lake shore was not breached. These cases are classed as relicted lands and are described below.

### Legal Effect of Avulsions Under State Law

**8-103.** The foregoing describes the effects of avulsion under Federal common law. However, State law must generally be applied to events affecting land after a Federal patent has issued, except that State law cannot deprive the United States of ownership, even as it relates

to avulsion. State laws regarding avulsion vary considerably from Federal common law and even among the various States.

Where a source of law decision has been determined as in sections 1-7 and 8-57 and State law has been deemed appropriate for governing survey work where an avulsion is present in an area containing alienated or acquired lands, an examination of State law must be made.

**8-104.** State statute, regulation, and case law must be examined for the appropriate test or tests to determine if an avulsion has occurred. The test may have even been written into the definition of avulsion. The next matter is how the law defines the fixing of the boundary:

- (1) Many State laws place great emphasis on the presence of sudden change in river position as a test for avulsion.
- (2) A number of States have the following statutory definition: "If a river or stream carries away, by sudden violence, a considerable and distinguishable part of a bank, and bears it to the opposite bank, or to another part of the same bank, the owner of the part carried away may reclaim it within a year after the owner of the land to which it has attached takes possession of it." Obviously, a river cannot pick up a considerable part of a bank and move it to the opposite bank. Case law must be examined to see how the State courts have interpreted this provision.
- (3) A number of States do not specify that an avulsion leaves an identifiable tract of land between the old and the new banks. Some States consider a stream that is considerably widened by erosion during a single storm to be an avulsion.
- (4) Some State court decisions have treated changes in rivers that were not avulsive as an avulsion as a means of settling a dispute.

### International Boundary River Avulsion

**8-105.** International Boundary Rivers are located on the Canadian Boundary as well as on the Mexican border along Texas, Arizona, and California. The Rio Grande River along the Mexican Border has had many problems with avulsions in past years. Both countries agree, however, that changes in the channel where the river finds a new course do not result in a boundary change, even between sovereign States.

Where past avulsive changes have occurred along the Colorado and the Rio Grande Rivers, the remnant of property left in the bordering country is called a “banco” (pronounced bawn’ko). Problems with bancos have been addressed by the International Boundary Commission. The intent of the Treaty of 1905 was to simplify the border between the two countries by eliminating small areas from the ownership of each neighboring country. The treaty described approximately 189 bancos.

A joint commission from the two nations supervised the identification and survey of the bancos and, following approval of the surveys, bancos that contain less than 250 hectares of land or less than 250 inhabitants were granted to the nation enclosing them. Information concerning the banco surveys can be obtained from the National Archives in Washington, DC, as part of the International Boundaries Records.

The International Boundary Commission will be contacted prior to beginning field work along an international boundary.

### Resurveys Where an Avulsion Has Occurred

**8-106.** As described above, avulsions that occurred prior to the original survey and before statehood are generally ignored because title to the lands was not affected, except for its possible effect on the topography. However, where withdrawals, entries, or claims have been made or patents have been issued, special consideration is to be given to the problem of rights that may have accrued under State law as well as Federal law and law from previous sovereigns, if applicable.

An office investigation is required to determine the facts and to form the basis for issuance of special instructions for survey or resurvey. It is possible to use a series of maps, surveys, and aerial photographs to identify problem areas but usually the combination of map, historical records, and photograph study should be supplemented by a field investigation.

**8-107.** Some of the items needed or to be accomplished in such an investigation are as follows:

- (1) A thorough determination as to whether an avulsion has actually occurred.
- (2) Identify the upstream and downstream limits of the avulsion. Absent legal constraints the limits are at the intersection of the medial or median line of the preavulsion river with an

extension of the medial or median line of the avulsed channel.

(3) The method for determining the location of the banks of the abandoned channel may consist of aerial photo interpretation, use of reliable maps made prior to the avulsion, or an on-the-ground survey.

(4) Determine the method for establishment of a division line between opposite ownerships along the avulsed channel.

(a) On a nonnavigable river the medial line or thread is generally used as the division line. In cases where the medial line is used, State law on measurement from the low water marks or the OHWMs must be considered.

(b) On navigable streams the State may own nothing or may own the bed up to the low water mark or up to the OHWM—a fact to be determined. If the work is in a State that has relinquished its title to the beds of navigable waters, the medial line or the thalweg may be the division line between opposing owners along the abandoned channel.

(5) Choose the method for establishing partition lines between adjoining owners along the abandoned channel.

(6) Identify obliterated or destroyed survey monuments that need to be restored.

See the Chapter VIII Notes for case studies on avulsion and boundaries.

### Legal Effects of Gradual Changes in Water Boundaries

**8-108.** Accretion has been defined, in general, as the grain-by-grain deposit of soil along the bank or bed of a stream or a lakeshore by the action of the water. The legal effect of accretion under Federal jurisdiction and in nearly all State jurisdictions is that an owner may keep accretions that attach to his or her lands. A check on the status of State law is required.

**8-109.** Reliction is the gradual uncovering of land caused by the lowering of the ordinary level or stage of a

body of water, usually by climatic change or by gradual increase in use of water upstream. The legal effect of reliction in nearly all jurisdictions is that an owner may keep relictions that attach to his or her lands.

**8-110.** Erosion is defined as the grain-by-grain removal of soil from the banks or bed of a stream or lake by the action of the water. The legal effect of erosion under Federal jurisdiction and under nearly all State jurisdictions is that an upland owner loses title to eroded land. A check on the status of State law is required.

**8-111.** Because the eroded land has ceased to exist, the rights to that land, the soil and geographic extent, ceases to exist. Normally, rights to subsequent accretions to the uneroded adjoining land derive their ownership rights from those rights in the uneroded land, not from a reestablishment of rights in the eroded lands even though the new accretions occupy the same geographic extent as the former eroded lands.

**8-112.** Some of the language from leading court decisions illustrates some of the considerations when dealing with accretions:

(1) Definitions are as follows:

(a) The accretion must be imperceptible. "Alluvion is an imperceptible increase, and that is added by alluvion which is added so gradually that no one can perceive how much is added at any one moment of time." (*County of St. Clair v. Lovington*, 90 U.S. 46 (1874).)

(b) The Court's definition of the test as to whether land formed slowly or not is much quoted: "The test as to what is gradual and imperceptible in the sense of the rule is, that though the witnesses may see from time to time that progress has been made, they could not perceive it while the process was going on." (*County of St. Clair v. Lovington*)

(2) "The erecting of artificial structures does not alter the application of the accretion doctrine . . . unless, perhaps, structures are erected for the specific purpose of causing the accretion." And, "Whether the Hoover Dam affected the course of the river is of no significance, for it . . . was not constructed for the purpose of reducing river-bed holdings." (*United States v. Claridge*, 416 F.2d 933 (9<sup>th</sup> Cir. 1969), *cert. denied*, 397 U.S. 961 (1970).)

(3) "It is like the common case of alluvion, where something is gradually added to land by an imperceptible increase. What is taken from the bank is an imperceptible increment to the flats, and passes to the owner of it, in the same manner, as if there had been a like increment to the bank, it would have passed to the riparian proprietor. He takes the title, subject to those common incidents, which may diminish or increase the extent of his boundaries." (*Dunlap v. Stetson*, 8 F. Cas. 75 (C.C.D. Me. 1827) (No. 4,164).)

(4) "The rule, everywhere admitted, that where the land encroaches upon the water by gradual and imperceptible degrees, the accretion or alluvion belongs to the owner of the land, is equally applicable to lands bounding on tide waters or on fresh waters, and to the King or the State as to private persons; and is independent of the law governing the title in the soil covered by the water." (*Shively v. Bowlby*, 152 U.S. 1 (1894).)

(5) Legislation cannot deprive a riparian proprietor of the right to future alluvion that may be deposited upon the proprietor's river front. The riparian right to future alluvion is a vested right. It is an inherent and essential attribute of the original property (*County of St. Clair*).

**8-113.** As a general statement, the law also considers erosion to be the opposite of accretion. Therefore, while the upland owner gets to keep accretion, he or she must also suffer the loss of land by the process of erosion. Again, States may have different rules.

**8-114.** There are practical problems connected with the loss of land by erosion under some State laws. It is difficult to distinguish between a rapid erosion and an avulsion in those jurisdictions that simply define avulsion as the sudden and perceptible change in the course of a river. Other State jurisdictions state that any accretions or erosion caused by human activities on a navigable river fixes the boundaries of the State owned beds on that river.

The banks of some alluvial rivers consist of a clay soil over a deep subsoil of sand. When a river flow is directed toward this sort of bank, the sand is quickly eroded beneath the surface to such an extent that very large slabs of land fall into the river at one time. Witnesses

may remember huge chunks of land falling into the river that they claim to be evidence of avulsion. The decision in *Nebraska v. Iowa*, above, discusses this fallacy. The action is nevertheless erosion.

### Lateral Extent of Accretions or Relictions

**8-115.** The quantity of accreted or relicted land in front of surveyed Federal interest land is the subject of accretion surveys. Whether Federal or State law controls the ownership of land accreted to riparian holdings has been answered in a series of cases.

In *Borax Consolidated Ltd. v. Los Angeles*, 296 U.S. 10 (1935), *reh'g denied*, 296 U.S. 664 (1936), the Supreme Court held that: "The question as to the extent of this federal grant, that is, as to the limit of the land conveyed, or the boundary between the upland and the tideland, is necessarily a federal question." (p. 22.)

The ownership of accretion to land covered by an Indian trust patent was considered in *United States v. Washington*, 294 F.2d 830 (1961), *cert. denied*, 369 U.S. 817 (1962). The Ninth Circuit Court of Appeals held that Federal law applied because of the underlying Federal title.

The general question of whether Federal or State law controls and what the Federal law is, on upland conveyed prior to statehood, as to ownership of accretion was considered in *Hughes v. State of Washington*, 389 U.S. 290 (1967). The Supreme Court ruled:

The question for decision is whether federal or state law controls the ownership of land, called accretion, gradually deposited by the ocean on adjoining upland property conveyed by the United States prior to statehood.

We hold that this question is governed by federal, not state, law and that under federal law Mrs. Hughes, who traces her title to a federal grant prior to statehood, is the owner of these accretions.

This brings us to the question of what the federal rule is. The State has not attempted to argue that federal law gives it title to these accretions, and it seems clear to us that it could not. A long and unbroken line of decisions of this Court establishes that the grantee of land bounded by a body of navigable water acquires a right to any natural and gradual accretion formed along the shore.

We therefore hold that petitioner is entitled to the accretion that has been gradually formed along her property by the ocean.

Therefore, wherever the United States retains title to the original subdivisions along a body of water, either navigable or nonnavigable, the Government may subdivide the lands formed by accretion or by recession of the water, since these, too, are Federal interest lands.

**8-116.** Federal law applies as to the limit and ownership of accretions at the time of the grant. In front of public domain lands, being lands the Government has never conveyed along a body of water either navigable or nonnavigable, the Government may subdivide the lands formed by accretion or by reliction. Since these too, are Federal lands, the Government may also complete sections formerly surveyed as fractional with its similarly owned lands, subject to valid existing rights.

**8-117.** Where States have ceded part or all of their lands below the OHWM to the upland owners, the United States becomes one of the grantees. The boundary between land of the United States and the adjoining land of other grantees below the OHWM must be determined by State law of the respective State.

**8-118.** Some alluvial rivers flow through extensive flood plains and have swept over areas several miles wide. In such situations, erosion may wash away and completely submerge Federal ownership lots along the riverbanks. At a later time, rivers are known to swing back the other way and accrete across the identical area of the eroded lot or lots. This situation is called emergence by accretion.

**8-119.** The title to record riparian parcels where the waterward boundary line has moved by erosion past the entire extent of the landward boundary line and subsequently the water recedes and soil emerges waterward of the landward boundary line by the action of accretion, is determined after a careful review of the (1) the land status of the impacted parcels, surface and subsurface estates, (2) the ownership of the bed of the water body, surface and subsurface estates, and (3) the history of the river movement. There are apparent conflicts in the cases on the topic, but some accepted rules can be summarized. The rules take into account not only the practical but the equitable considerations in this matter. The question of title to the parcel with public domain land status is governed by Federal law.



**8-120.** For a record riparian parcel with public domain status, the United States is divested of title when there is a situation involving all of the following elements:

- (1) the surface of the record riparian parcel must have been washed away entirely and been totally submerged by the action of erosion;
- (2) a navigable river; and
- (3) the title to the bed has not been relinquished by the State in favor of the record riparian owner or was reserved by the Federal Government.

In these situations the formerly remote riparian parcel is made riparian by erosion and then receives the benefit of subsequent accretions.

**8-121.** Conversely, the United States is not divested of title of a record riparian parcel with public domain status where any of the following are present:

- (1) the surface of the record riparian parcel has not been washed away entirely and totally submerged by the action of erosion;
- (2) the waterward boundary line of the record riparian parcel does not move by erosion past the entire extent of the landward boundary line of the same parcel;
- (3) the action on the land is avulsive; or
- (4) the record riparian parcel is submerged by the action of submergence (section 8-125).

In the case where the public domain parcel has partially eroded to the extent the remote parcel becomes riparian and subsequently upland is formed by accretion, the once remote parcel is restored only to the extent of its former limits.

**8-122.** A boundary line cannot be assumed to have moved by erosion past the entire extent of the landward boundary of the record riparian public domain parcel without positive evidence. Positive evidence is direct proof of the facts establishing that the change has occurred and does not arise from any presumption. This evidence may be in the form of historical aerial photography, local newspaper articles, witness testimony, or other evidence of the factual circumstances.

**8-123.** State law is applicable where the land status of the record riparian parcel is acquired or non-Federal.

The rules vary from State to State. Some States have adopted the Federal rule.

**8-124.** The surveyor must be aware that the question of title in these cases will be influenced by the equities in cases of erosion and accretion where the river stabilizes in its new location for a long period of time and the remote riparian parcel owner establishes riparian rights through use and occupancy. After all the facts of the case have been gathered, the surveyor should consult with legal counsel before monumenting the boundaries of the Federal interest land.

**8-125.** The “Doctrine of Reemergence” holds that where the record riparian parcel is submerged due to an increase in water level, not erosion, and then subsequently reemerges through a subsidence of the water, such that the same soil is exposed, title remains in the record riparian parcel owner, rather than the remote parcel owner. The doctrine is an exception to the rule of accretion and involves the easy identification of the same identifiable soil that has reemerged and the action of the rising and falling of water levels or the rising and falling of upland by means other than accretion. The doctrine is not applicable where land has eroded away and then been restored through the process of accretion.

**8-126.** Where accretions or relictions to intermingled alienated and Federal interest lands are important, an accretion or reliction survey is ordered if it is desired to mark the boundaries of the Federal interest lands. Any riparian owner, including the Government, is entitled to accreted or relicted lands *in front of* their basic holdings, in the same relative proportions to neighboring parcels as was established by earlier survey.

It is possible the proportionate frontage method could result in skewed partition lines placing accretions or relictions other than in front of the basic holding. Partitioning or the division of accretions must result in equitable apportionment and is achieved where the results place the accretions in front of the basic holding. If a selected method fails to do this, an alternate method, such as those discussed in sections 8-133 through 8-145 should be selected.

**8-127.** In the case of navigable waters, the extent of the survey is to the OHWM. However, the Government may own lands below the OHWM in the bed of the navigable waters where State law has relinquished title to such lands to upland owners or where title to the bed was explicitly reserved by the United States before statehood.



**8-128.** In the case of nonnavigable waters the extent of the survey is to the medial line of the stream, the medial line being determined by measurement from appropriate lines on the opposing banks or to the thread for topography or bank configuration and location reasons.

**8-129.** However, new meanders are shown to delineate the uplands from the bed in front of the Federal interest lands only; the process is called remeandering. Only Federal interest lands are remeandered; alienated lands may be shown on survey plats as a result of an informative traverse to show the present OHWMs. Whether called new meanders, remeanders, or informative traverse, they may be shown on the plat.

**8-130.** The following steps are considered to be a minimum requirement for preparation for the field survey:

(1) The reach of the river to be analyzed must include sufficient upstream and downstream sections to understand the processes by which the changes have occurred in order to equitably locate the partition lines. Studying this extended area allows the surveyor to understand how the banks moved and whether avulsions were involved, provides for zero accretion points or their equivalents in proportional frontage calculations, and can support an alternative method of partitioning if the proportional frontage method results do not lie in front of the basic holding.

(2) Obtain a series of surveys, reliable maps or aerial photographs of the river that were produced between the dates of statehood, original survey, treaty, order, entry, claim, settlement, or patent, as appropriate, and the present time. The surveys, maps, and photographs should be reduced or enlarged to a common scale and common method of showing the OHWM. This step is necessary because some older maps show sand bars as dotted areas and upland areas by appropriate symbols. U.S. Geological Survey maps show the edge of the water at the time that the aerial photos were flown. These situations require the surveyor to estimate the location of the OHWM at the time the survey map was prepared or the photo was flown.

(3) Define the boundaries of the basic holdings by survey of the Federal interest lands.

Identifiable and existent corners are used to locate alienated areas.

(4) Starting with the original survey and the oldest map, indicate on a worksheet the effect of each newer survey, map or photo. Watch for possible avulsive types of changes and record the direction and area of accretions for each change.

(5) Ensure that each accretion is in direct contact with the basic Federal holdings or previous accretions. For example, if an island in a navigable river formed after statehood from the bed of the river and the channel between the island and the mainland gradually dried up due to accretions, the island and half of the dried channel would belong to the State as owner of the riverbed, and the other half of the channel would belong to the riparian owner on the riverbank opposite the island.

(6) When the newest survey or map shows the extent of accretions to Federal interest lands, meander the current OHWM along the bank or banks of the river.

**8-131.** Accretion and reliction surveys conducted during or in anticipation of a dispute between the Federal Government and the State that owns the bed of the stream will require extra care and documentation in approximating the OHWM while remeandering the new accretions.

## Partition Lines

**8-132.** Partition lines for accreted or relicted areas are established in accordance with the same principles for both rivers and lakes. Some variation is necessary in adapting the methods to particular cases. Care will be taken to award each basic holding on the shore the part of the bed *in front of* it. If one method fails to do this, another method, or a combination of methods, will be used.

The processes for surveying partition lines, e.g., division of accretion lines, division of reliction lines, or division of the bed lines, is similar. Typically, only the type of lands being divided is different. Typically, when the bed is to be partitioned and there are also substantial accretions or relictions to the upland, the upland is partitioned before the bed, a two-step process.

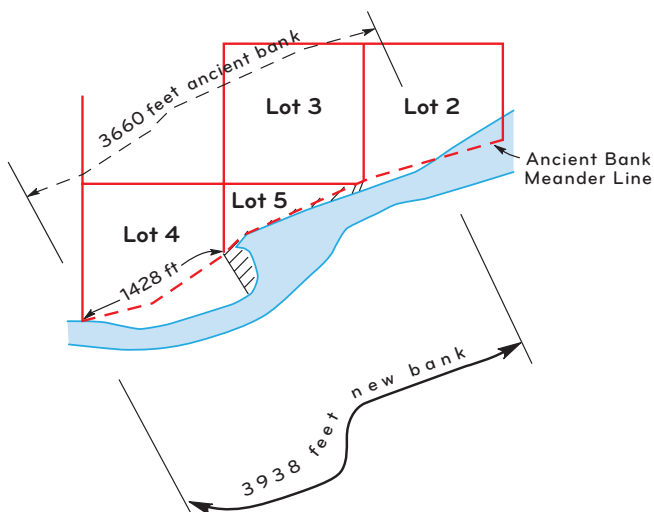
## Partition Lines and Apportionment of Accretions on Navigable Waters

**8-133.** The five different methods for establishing division of accretion lines between intermingled upland ownerships on navigable waters for use in official surveys are:

(1) *The proportionate shoreline method.* This method was specified in the precedent setting case of *Johnston v. Jones*, 66 U.S. 209 (1862). In that method, each reach of the river is to be considered separately using the proportions of each upland lot's frontage to the total length of accreted bank in proportion to the ratio of each ownership along the ancient bank (usually measured along the meander line) to the total ancient bank frontage (figure 8-26). If the bank or shoreline has deep indentations or sharp projections, the general trend of shoreline or bank line is to be used in setting the ratio.

The points used for starting and stopping the apportionment are preferably chosen where there is no erosion or any accretions to the original meanders. These points are called zero accretion points (ZAPs). If there are no such points available, artificial ZAPs are created using lines perpendicular to the general course of the river at places where the bank and the general course of the river are nearly parallel.

(2) *The perpendicular method.* Partition lines are established between the location of the record meander, special meander, or auxiliary meander



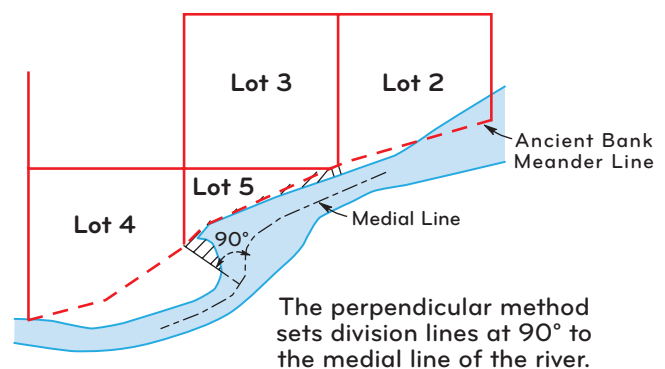
**Figure 8-26.** The proportionate shoreline method, where the new shoreline length is in direct ratio to the original shoreline length.

corner and the perpendicular intersection with the thread of the stream, medial line, or thalweg of the river (figure 8-27). It is possible due to configuration of the river bed's dividing line, the thread, medial, or thalweg that no perpendicular intersection occurs. (This may happen on an outside bend). If this happens, extend the tangents of the dividing line, allowing for an intersection, and choose the intersection point that best locates the partitioned areas so they are in front of the basic holding of the adjoining interests. When a perpendicular to the bank is used, it is called the colonial method (figure 8-28).

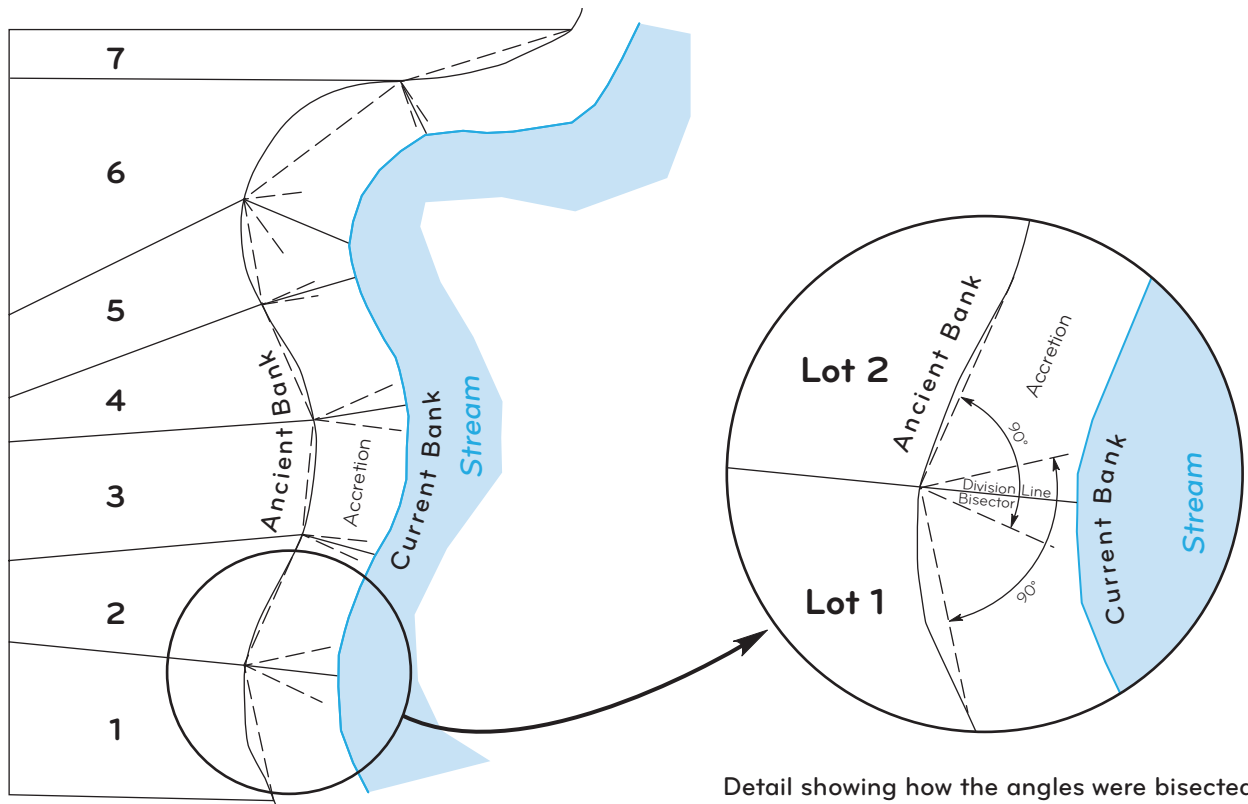
(3) *The proportionate acreage method.* This method is applied where the area of the accretions are considered to be more important than the new water frontage (figure 8-29).

(4) *The extension of the property line method.* The division line between basic holdings of the two owners is merely extended until it meets the new bank of the river. Extension of section or subdivision-of-section line may be used for setting a new meander corner (figure 8-30). With a dependent resurvey, accretions have often made the location of recovered meander corners appear distant from the OHWM. If the abutting lands are all the same Federal interest lands, a new meander corner may be established by extending the section line toward the body of water.

(5) *A combination of the proportionate shoreline method and the perpendicular method.* Because nearly all the precedent litigation on these subjects has centered on the requirement of an equitable division of the accretions, the



**Figure 8-27.** The perpendicular (normal) method is usually equitable where the old bank line is sinuous. It is also useful as a starting place for the proportionate shoreline method).



The Court's solution bisected angles between adjacent perpendiculars.

Figure 8-28. The colonial method of partitioning.

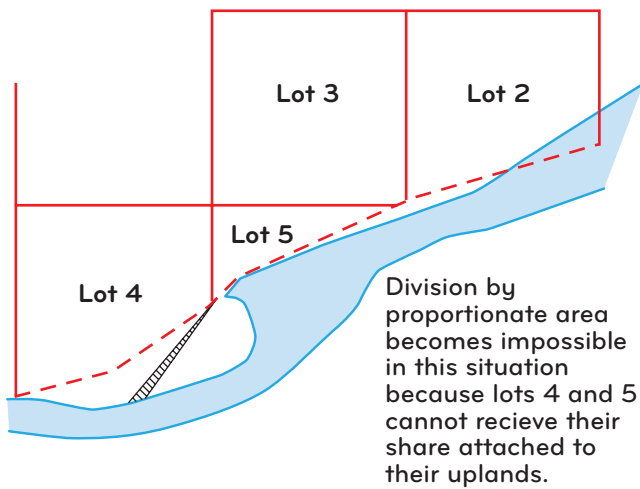


Figure 8-29. The proportionate acreage method gives the riparian owners a proportionate share of the accreted land based on the total extent of their frontage, related to the total quantity of the accreted land to be divided.

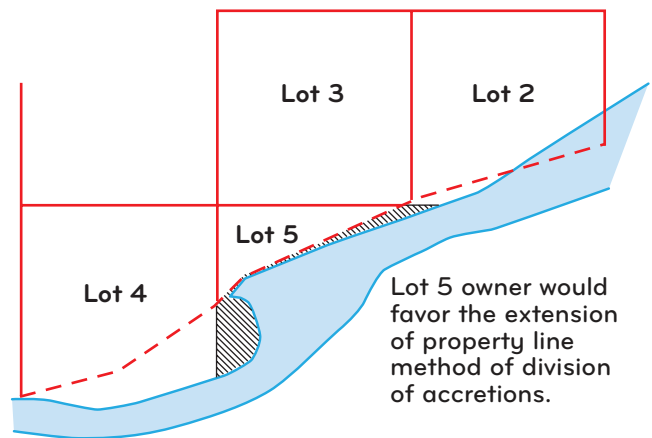


Figure 8-30. The extension of property line method.

rigid rules above are subject to modification on a case-by-case basis. For a division of accretion to be equitable, each owner must be allotted a fair share of the accretions. To be able to fairly estimate what is equitable, the surveyor should make a tentative solution to the allocation and

then consider each ownership in turn, mentally or numerically consider the tentative lines as each actual owner would see them.

**8-134.** Once a satisfactory system for partitioning is achieved, monuments are to be placed on the corners of

the Federal interest land using standard monumentation with the caps marked as MC for meander corners and SMC for special meander corners.

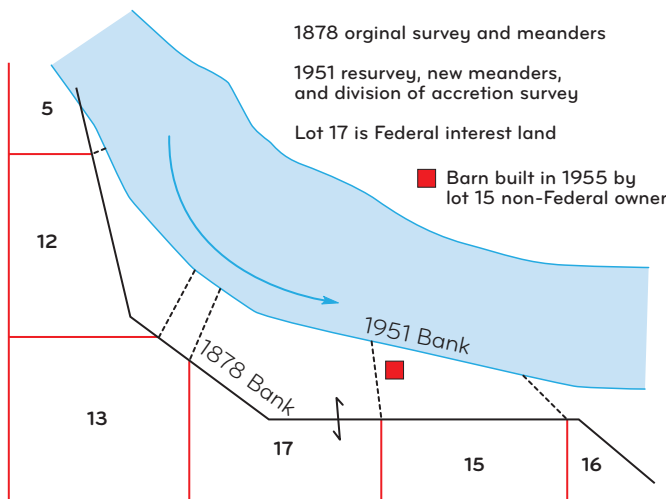
**8-135.** The position of previously set meander or special meander corners often needs to be maintained, even when new corners are established. To ease identification in the field notes and on the plat, the corners should be referred to by the year of the survey, when they were officially filed, e.g., 1856 meander corner, 2000 meander corner, etc. The new meander corner is then referred to by the year of the new survey.

**8-136.** In the event that a dependent resurvey of intermingled ownership of river front property encounters additional accretions that have occurred to a prior approved resurvey, the waterward endpoint of the last partition line will become the starting point for the new division of accretions by a new partition line (figures 8-31 and 8-32). The prior approved resurvey MC or SMC is thus treated as the ancient bank.

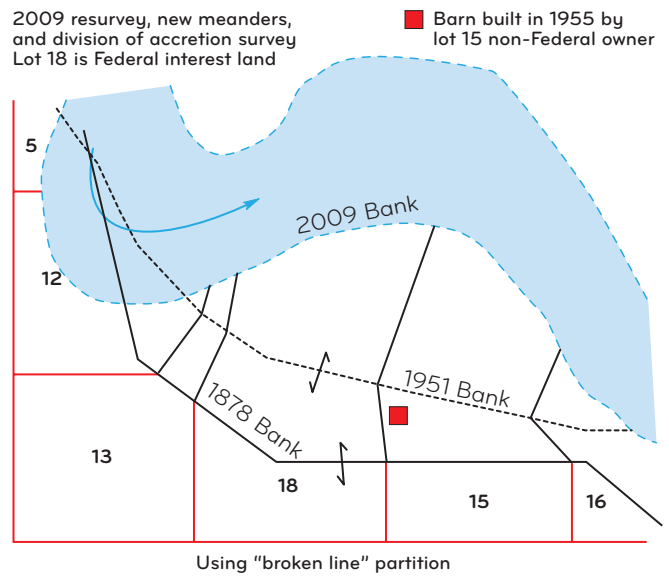
**8-137.** In some cases where no improvements or use have been made in reliance on the last partition line and the above guidance would unnecessarily complicate the record, the landward start point of the last partition line may become the starting point for the new division of accretions by a new, straight partition line. In these cases the waterward end point monument of the last partition line will be tied to, amended, and buried in place (figure 8-33).

**Division of Relicted Beds of Lakes**

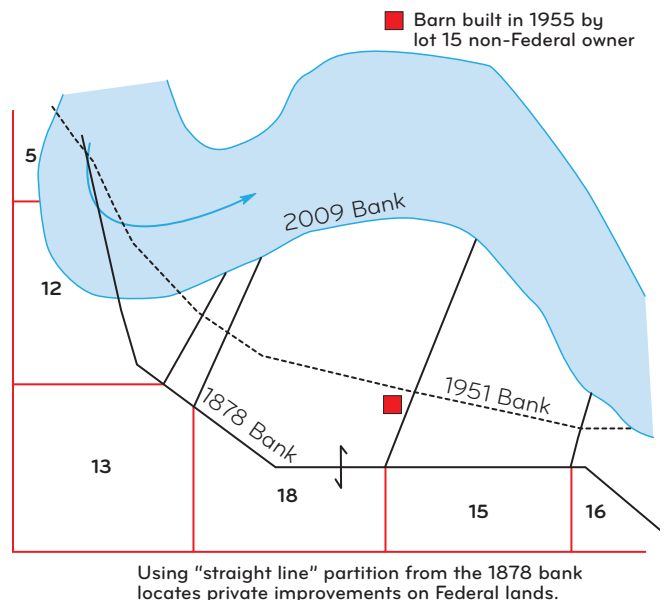
**8-138.** While the shores of lakes do not usually move imperceptibly by accretion, it is common to have



**Figure 8-31.** Division of accretion survey and establishment of partition lines.



**Figure 8-32.** Dependent resurvey of an intermediate division of accretion survey, division of new accretions, and extension of partition lines, i.e., broken line partition.



**Figure 8-33.** Division of accretions and establishment of new partition lines, i.e., straight line partition.

lakes relict. The legal effect of reliction on boundaries and ownership, as stated above, is identical to that of accretion.

As a survey matter, the apportionment of reliction of lakes differs from the ordinary accretion problem in that the shape of the relictions are entirely unlike that of a river. On a lake, the relictions usually are located around the entire lake, or nearly so, because the water has permanently dropped in elevation.

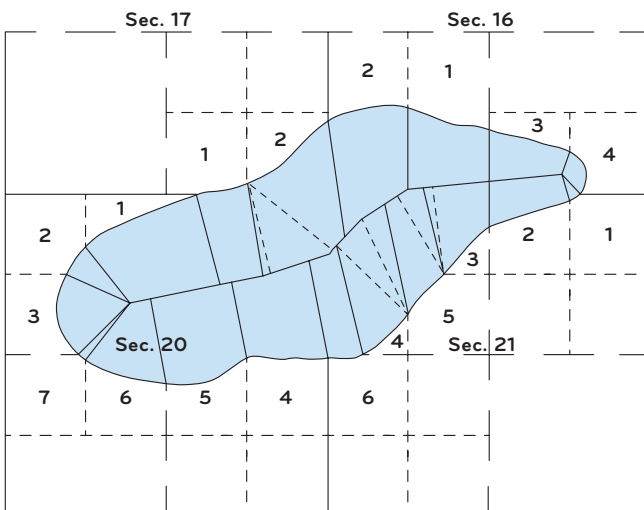
The method of procedure depends on the shape of the shore line. The courts have generally held that the bed of a round lake should be divided among the riparian owners by ascertaining the center point and connecting that point by straight lines to the boundary corners on the shore. When a lake is long in comparison with the width, the methods applied to streams, with converging lines only at the ends, make the best division.

In figure 8-34, the ends of the lake have been treated as arcs of a circle; the remainder of the bed has been divided by use of proportionate measurement along the medial line. In this case, perpendiculars to the medial line would have resulted in the encroachment of some lots in front of others, and two perpendiculars could have been projected from several points as indicated by the dashed lines.

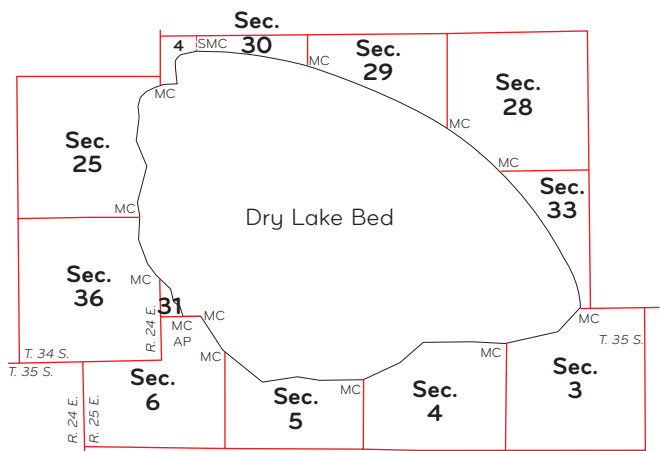
Examples of the apportionment of the beds of lakes are covered in *Public Lands Surveying: A Casebook* published by the BLM (figure 8-35). There are five general methods for the apportionment of relictions along lakeshores:

- (1) the round lake method;
- (2) the long lake method;
- (3) the proportionate medial line method;
- (4) the colonial method; and
- (5) a combination of the above methods.

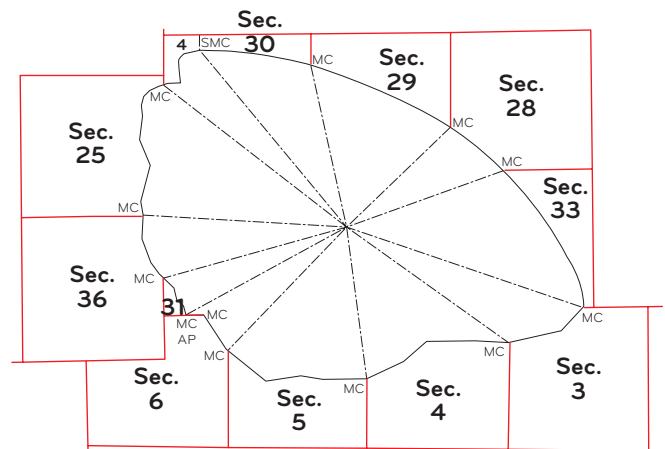
**8-139.** The round lake method treats the bed of the lake as a pie (figure 8-36). After a center is chosen, which



**Figure 8-34.** Apportionment of the bed of a meandered non-navigable lake.



**Figure 8-35.** Flagstaff Lake area in Oregon showing the original survey pattern. A prior valid survey had created the unusual shape of section 6, which did not affect the division of the relictions. Flagstaff Lake was one of several non-navigable dry lakes in Oregon that had been meandered in the original surveys and that were mostly dry lakes (playas) being claimed by the BLM as public lands. Any alienated lands bordering on the lake were to receive apportioned lake beds (relictions) equitably.



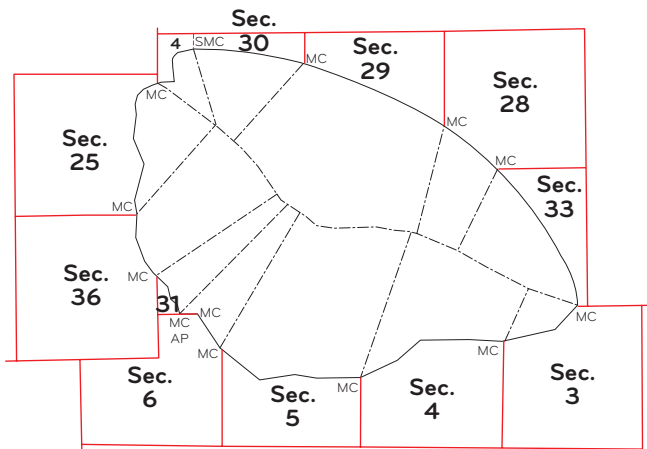
**Figure 8-36.** The round lake method for division of relictions treats the lake bed as slices of pie.

will most equitably divide the relictions, division lines are drawn to the center from each ownership boundary and these lines become the boundary lines. If Flagstaff Lake were to be apportioned in this manner, the division would be as shown.

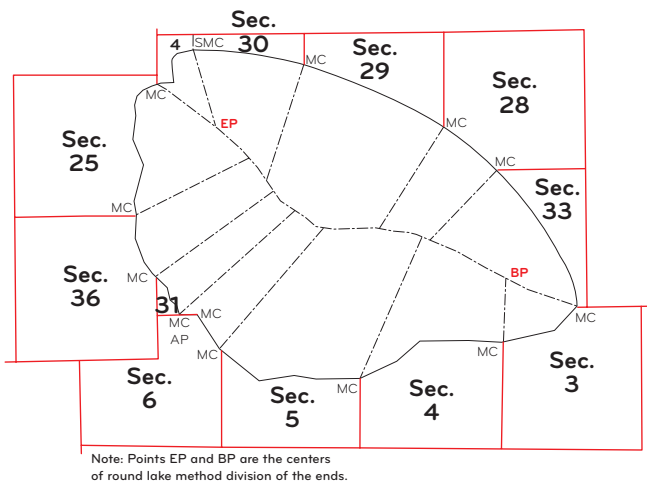
**8-140.** The long lake method treats the bed of the lake as a medial line through the center of the lake, with perpendiculars to the medial line from the meander corners, and with the ends divided using the principles used in the round lake method (figure 8-37).

In figure 8-38 the right angles were turned from the medial line.





**Figure 8-37.** The long lake method uses a medial line between end points at a pie type division. Between the end lines, perpendiculars are constructed to the ownership division lines.



Note: Points EP and BP are the centers of round lake method division of the ends.

**Figure 8-38.** The proportionate medial line method uses the *Johnston v. Jones* idea between two end points selected by the round lake method.

**8-141.** The proportionate medial line method uses the *Johnston v. Jones* idea—each owner receives frontage in proportion to his or her original frontage along the water body. As in river work, small bays and spits may have to be smoothed out to make an equitable division.

**8-142.** The colonial method measures the 90 degree angle from the frontage instead of the medial line.

**8-143.** Equitable distribution of the relictions of the bed is the desired goal in these division problems. Only by careful choice of methods and by discussion of values with the owners involved can a surveyor reach an equitable solution.

**8-144.** Where the Government owns all of the upland lots fronting on a reliction area, it is possible that the

pattern of section lines is extended across the relict area. This is termed a completion survey.

**8-145.** Cases are known where upland owners have made boundary line agreements among themselves which effectively completed the sections on relict areas. That happened along Devils Lake, North Dakota. Owners filed plats that showed how the divisions were made between them using a completion-of-the-sections pattern and that were upheld by the courts. If the United States is not deprived of significant lands and there is no conflicting overriding Federal interest, this type of local agreement will be acceptable in defining Federal ownership and boundaries of relict lands.

### Division of the Beds of Meandered Nonnavigable Rivers, Including Accretions or Relictions

**8-146.** Because each upland owner along a meandered nonnavigable stream owns to the medial line, median line, or the thread, depending on the wording and intent of the original grant, the first thing to be addressed is the position of this boundary line. Second, the extent of each of the ownerships toward this boundary line is to be determined and, concurrently, the location of the upland points along the bank where partition lines are to originate must be determined. Third, the end points of the partition lines are located along the medial line, median line, or the thread such that the division is equitable to all parties. Finally, the present day division of the bed is determined, including accretions or relictions (sections 8-133 and 8-152).

**8-147.** Factors influencing ownership and boundary location for the above include:

- (1) land status of the Federal interest lands;
- (2) spatial relationship to the Federal interest lands;
- (3) common grantor source of law (foreign, Federal, or other) of the grant; and
- (4) State law.

**8-148.** The presence of islands in such rivers may affect the location of the medial or median line. If one or more islands have been surveyed and meandered, there are at least two lines to be determined, one on each side of a surveyed island. If a Federal interest island is identified to be meandered, the current OHWMs along the circumference of the island are meandered. The low water

mark may be substituted for OHWM in States where the low water mark affects non-Federal lands.

**8-149.** A surveyed and meandered public domain island represents an irregular unit, typically identified as a lot, bounded by the medial or median lines in the channels on either side of the island. Where an island is totally submerged, at OHWM, by the action of erosion, the island is no longer considered in the medial or median line determination, i.e., there is no island OHWM to locate a medial or median line. If, through later accretion to the bed, a new island is subsequently reestablished above the OHWM at the approximate record location of the former island, and title to the uplands is held by the Federal Government, the OHWM of the new island should be used in the medial or median line determinations in the two channels, and a new unit identified.

However, if the title to only one upland of the water body remains in the Federal Government, when a new island is reestablished above the OHWM at the approximate record location of the former island, then the medial or median line of the entire water body, disregarding the new island, is found. This may result in all, part, or none of the new island being in Federal interest, depending on the relationship of the island to the medial line. The ownership of the former bed will be reflected in the ownership of the subsequently formed island. After ownership of the newly formed island is established, the OHWM of the new island is not used in subsequent medial or median line determinations for purposes of jurisdictional boundaries or title to subsequent islands formed by accretion.

**8-150.** For a meandered island that has been alienated or acquired, where the island is totally submerged by the action of erosion, State law must be examined to determine whether the record owner of the island has been divested of title. If through later accretion to the bed a new island is subsequently reestablished at the approximate record location and the title determination concludes the record owner still has title, the current OHWM of the new island is to be run and considered in the medial or median line determinations.

The next step in the process is to determine the upland division lines and placement of the upland end of the partition lines. Where there has been a general trend of accretion to the record banks, the restoration of the record meander line can proceed as in section 8-17 and sections 8-182 through 8-186.

**8-151.** If erosion of the record bank has occurred, the owners of alienated or acquired lands may have a valid

claim to the exposed bed between the present day bank and the record meander line. State law must be examined to determine whether the direction of the lot line from a remote corner is used to intersect the present bank or whether the record position of the original subdivision corner is to be used. It has always been recognized that an upland owner of nonnavigable waters owns the bed of the waters from his or her upland to the medial line.

**8-152.** If proportionment along the medial line, median line, or thread is used to reach an equitable solution to the division of accretions, then the division of accretions, as well as division of the active river bed, can be done without involving separate determinations of the partition line and the division of the active river bed (sections 8-133, 8-146, and 8-154).

**8-153.** Where an equitable division of the upland involves a combination of proportionment measurement and, say, the perpendicular method, the additional step of dividing the bed may be required. Again the goal is to achieve resulting division lines that are equitable to all parties. A straight-line proportionment along the medial or median line is the method of choice, at least for a first partition, but again a combination of methods may be necessary.

**8-154.** Instructions for surveying the partition lines within the beds of meandered nonnavigable rivers are found in *Rule for Establishing Boundaries of Riparian Claims in the North Half of the Bed of Red River, Oklahoma*, 50 Pub. Lands Dec. 216 (1923). As stated in the syllabus:

In establishing the side boundaries of claims of riparian proprietors to the area between the original meander line on the north and the medial line of Red River in Oklahoma in accordance with the decisions of the Supreme Court in the case of *Oklahoma v. Texas*, lines should be run from points representing the limits of frontage of the original claims on the meander line to points on the medial line at distances thereon proportionate to the lengths of frontage of the respective abutting owners.

This is an adaptation of the rule outlined in the case of *Johnston v. Jones*, 66 U.S. 209 (1862); the new frontage along the water boundary of an accreted area is apportioned in the same ratio as the frontage along the ancient bank. In applying the rule, if the shore has deep indentations or sharp projections, the general shoreline,

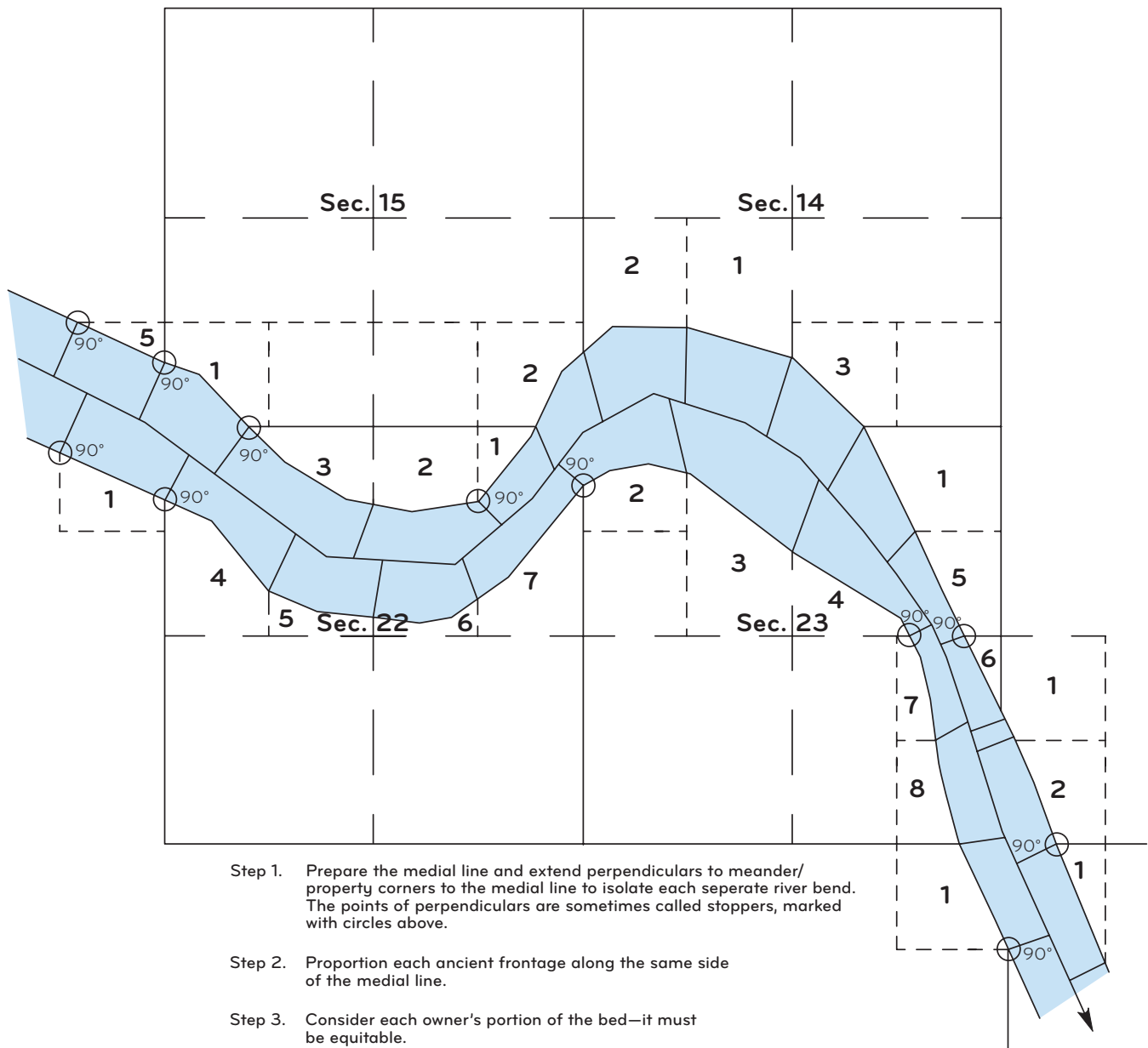
not the actual length, should be taken in setting the ratio. The division of accretion lines will connect the claim corners on the original meander line with the claim corners on the new meander line.

Perpendicular lines to the meander lines are extended to the medial line, above and below each bend in the river in the area to be apportioned, at points where the river's course is straight, or nearly so. The intermediate distance along the medial line is then prorated according to the new frontage (figure 8-39). The division of the bed (partition) lines will connect the claim corners

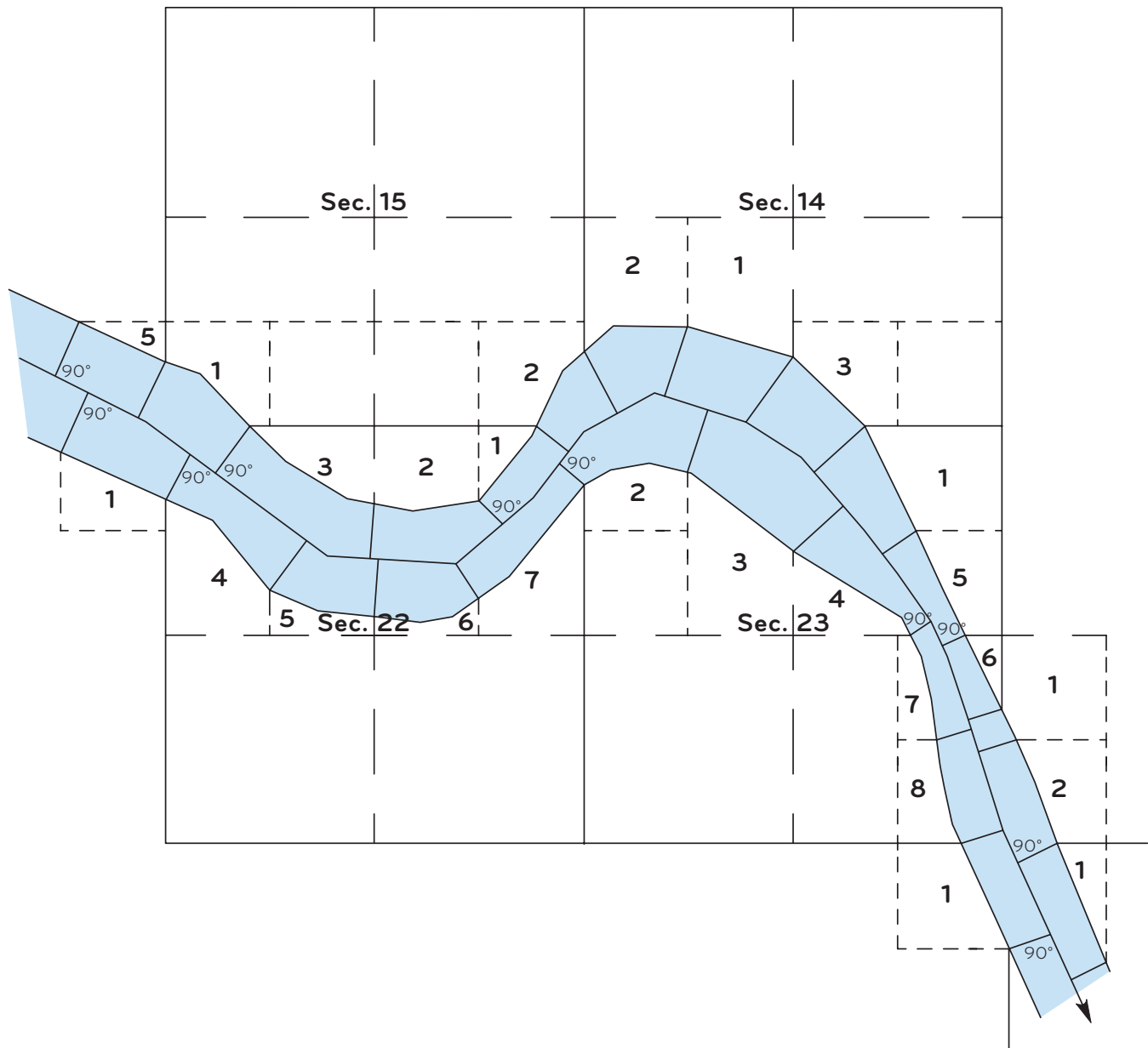
on the new meander line with the claim corners on the medial line.

An alternate method is to extend each partition line perpendicular to the medial line. This method awards to each riparian lot the area immediately in front of it (figure 8-40).

**8-155.** Where a winding stream course causes the perpendiculars to deflect rapidly, more than one perpendicular can sometimes be extended from a single point on the shore, or perhaps no suitable perpendicular can be



**Figure 8-39.** A method of apportioning the bed of a meandered non-navigable river. Points were selected above and below the bend from which perpendiculars to the meander lines were extended to the medial line. The intervals along the medial line were determined by proportionate measurement.



**Figure 8-40.** An alternate method of apportioning the bed of a meandered nonnavigable river by extending perpendiculars to the medial line to the meander/property corners.

drawn. A combination of methods should then have to be used to obtain equitable results. For instance, perpendiculars might be extended to the medial line at straight parts of the river, and the intermediate parts apportioned along the medial line.

**8-156.** In some cases a method of holding the section line as the boundary across the river is used if the river (1) was meandered to segregate upland acreage but was never a basis for a riparian boundary in a patent or subsequent deed or (2) is relatively narrow and/or still active, and other apportionment methods would unnecessarily complicate the record.

See the Chapter VIII Notes for case studies on gradual changes and boundaries.

### Boundaries in Front of Riparian Acquired or Non-Federal Lands

**8-157.** Surveys of alienated lands that are in the process of consideration for acquisition (future interest) or previously alienated land that has already been acquired (acquired lands) are within Federal survey jurisdiction.

Once lands have left Federal ownership, the potential for unwritten rights to ripen into fee title exists. These rights are defined by State law and must be examined as part of an official survey using State law as guidelines.

In order to assure that those rights are respected, acquired lands surveys are to be based upon State laws unless a proper source of law decision determines otherwise. In many cases the State may borrow Federal law. Special instructions must address these requirements. Survey field notes of acquired or non-Federal lands will describe when State law was applicable and how it was applied.

## Islands and Sandbars

**8-158.** Islands in meandered nonnavigable rivers in existence at the time of an official survey but left unsurveyed remain part of the public domain and subject to survey and identification.

By policy and statute, islands in rivers, lakes, and offshore were surveyed if worth the expense of surveying. Isolated small island tracts were seldom surveyed, for practicable and economical reasons, but have been always considered “unsurveyed public lands” until surveyed and platted (Act of August 3, 1846, sec. 5, 9 Stat. 51 as amended; Rev. Stat. 2455; 43 U.S.C. 1171 (repealed sec. 703(a) of Pub. L. 94-579); and Act of May 30, 1862, sec. 10, 12 Stat. 409 as amended; Rev. Stat. 2401; 43 U.S.C. 759). Many islands were surveyed only after application was made by settlers with a sum sufficient to pay for the survey. The special instructions should be clear on what is expected if unsurveyed islands are encountered during survey.

**8-159.** Some court decisions have not recognized United States ownership of unsurveyed islands in meandered nonnavigable waters where the United States did not reserve permanent access along the riverbank or lake shore. Where a river is navigable, the public, including the United States, has access to the island by water at all practical times.

**8-160.** Meandered islands in Federal ownership are subject to remeandering. However, no island, patented or otherwise alienated, is ordinarily remeandered, as is the case with other alienated lands, unless a medial or median line calculation is needed. In that case, informative traverses are run (sections 3-191 through 3-201).

## Accretions to Islands

**8-161.** Islands in navigable as well as nonnavigable rivers may change their lateral boundaries by the process of erosion and accretion, identical to uplands. This statement applies to unsurveyed islands, surveyed public domain islands, acquired islands, and alienated islands.

Erosion of the upstream end of islands and deposition on the downstream end of islands has the effect of moving the entire island downstream. On a meandered nonnavigable river where the upland owners take to the medial line, State law may govern whether a downstream owner owns an island or part of an island, surveyed or unsurveyed, moving onto his or her portion of the riverbed. An island moving downstream in a navigable river where the same State owns the riverbed around the island has no change of ownership boundary as the island moves.

**8-162.** In a case where the channel between an island and the mainland that are in different ownership and the channel flow imperceptibly diminishes until the former channel is dry, the boundary between the ownerships will be fixed at the middle of the last trickle of flow (the thread) through the channel.

**8-163.** Islands formed subsequent to the filing of the latest official survey in meandered nonnavigable rivers are generally classed as riverbed. The recently formed island is thus located on the land of the riverbed owner. The medial line between the outer banks of the water body will divide the island as well as the riverbed.

**8-164.** Where an island was meandered in a nonnavigable river during the original survey, there are medial lines on each side of the surveyed island and an owner fronting on the river would have his or her boundary on the medial line between the island and the mainland.

See the Chapter VIII Notes for case studies on islands.

## The Island Rule

**8-165.** The Island Rule is a rule of decision on navigable rivers used as boundaries. The rule states that ownerships are fixed when the volume of flow in the main channel of a river becomes less on one side of an island than on the other side, and navigation changes from the low flow side to the other side of the island. In that situation the boundary remains in the old channel akin to an avulsion. Unlike the case of avulsion, however, because



water is still flowing in the old channel the boundary there may continue to move by erosion and accretion.

See the Chapter VIII Notes for case studies on the island rule.

## Erroneously Omitted Lands

**8-166.** The title erroneously omitted lands is applied to lands, not shown on the plat of the original survey, that were excluded from the survey by some gross discrepancy in the location of a meander line. The unsurveyed land typically lies between the actual bank of a lake, stream, or tidewater and the record meander line. Lands exposed by changes in water level or accreted subsequent to survey are not erroneously omitted lands.

**8-167.** In some older surveys temporarily flooded lands, swamp and overflowed lands (section 3-211) were meandered as if they were permanent bodies of water. In a few cases, meander lines were reported where no body of water ever existed in fact. In still other instances, several lakes have been surveyed as one lake. All are treated in the same manner as those where the discrepancy is a grossly erroneous position of the record meander line. The converse is sometimes found where the record meander line leaves the bank and extends into the body of water. A water area will thus be shown as land.

**8-168.** Discrepancies between the original meander lines and OHWM or line of MHT of water bodies at the time of survey fall into two classes. The first class includes merely technical differences found in many older surveys including meander lines that were run (1) along bluffs above the river banks or (2) at some insignificant distance (for the date and locale) from the OHWM or line of MHT and also where the meanders prove to be located at some insignificant distance in the water. Such technical differences, when combined with the long-standing policy of conveyance of all the public lands in front of riparian lottings, are usually included with accretions. Such technical differences do not contradict the principle that in a public grant nothing passes by implication. Unless the grant is clear and explicit regarding the property conveyed, a construction shall be adopted that favors the sovereign rather than the grantee.

The second class includes discrepancies that are considered to be gross error such that had the Government been aware of the magnitude of the error, patent would not have been issued. These areas are considered to be “erroneously omitted lands.” The guidelines for

determining the class of a particular case are laid down in court and departmental decisions, particularly *Wackerli v. Morton*, 390 F. Supp. 962 (D. Idaho 1975); *Burt A. Wackerli*, 73 Interior Dec. 280 (1966).

**8-169.** If land is to be regarded as erroneously omitted from survey, it must first be shown affirmatively that the area was *land in place* at the date of the original subdivision of the township. Then, if the land is similar in character to the adjoining surveyed lands, the usual inference that the official survey was correct may be set aside, and the conclusion substituted that the omitted land should have been covered by that survey. Where these facts exist, the original meander line becomes a “fixed and limiting boundary,” and the omitted lands remain in Federal ownership, subject to survey and disposal or retention. There must be clear and convincing evidence to show that the representations of the original plat and field notes are grossly erroneous.

**8-170.** The determination as to whether a particular situation falls within the general rule that meander lines are not run as boundaries and the river establishes the boundary of the alienated land, or the erroneously omitted lands exception to it is in close cases difficult to make. The area of the land omitted as compared with the area patented, the value of the land at the time of the original survey, the difficulty involved in surveying the land due to its topography, and the distance of the original meander line from the actual water line are some of the factors that are considered in making this determination.

**8-171.** A common measure of the error is the ratio of the acreage omitted in front of a lot or lots to the area of the alienated lot or lots. If the omitted area is, e.g., two times the area of the base lot or more, the patentee must have been aware of the windfall at the time of entry or patent, and the error was grossly erroneous. However, the erroneously omitted lands exception must not be applied solely on the basis of mere quantitative analysis, but also upon consideration of the particular equitable factors bearing on unjust enrichment.

**8-172.** A long line of litigation has addressed omitted lands. There is no requirement to show the source of the error in the meander line but only that the line as run and as represented on the plat and in the field notes is, in effect, grossly in error. The rule is concisely stated in *John McClennen*, 29 Pub. Lands Dec. 514 (1900):

It is not necessary to search for the source of the error. The result is the same whether such error

arose from mistake, inadvertence, incompetency or fraud on the part of the men who made the former survey.

**8-173.** Surveys to identify omitted lands make the adjusted original meander line a fixed and limiting boundary, segregating the previously surveyed areas from the unsurveyed public lands. The meander line is reestablished and marked with permanent monuments at the old angle points.

**8-174.** Retracement between successive meander corners nearly always will show differences from the record in latitude and departure. The positions of the angle (meander) points are adjusted by the broken boundary method described in section 7-53. The angle points are given serial numbers that do not duplicate numbers that have been previously assigned in that section. The monuments are marked as shown in section 4-48.

**8-175.** The position of the original meander line having been determined, the survey is extended across the unsurveyed areas. Fractional sections should be completed, and new meander corners set on the extended survey lines. Finally, a new meander line is then surveyed in front of the omitted land. Auxiliary meander corners are then established at the intersection of the original meanders, now a fixed and limiting boundary, with the new meanders.

**8-176.** Applications for the extension of the subdivisional lines to include the areas erroneously omitted from the original survey may be initiated either by settlers on the omitted land or by the owners of the adjoining land. Occupants, local political subdivisions, and States may be conveyed such omitted lands, after identification by survey, as described in section 211(b) of the Federal Land Policy and Management Act (43 U.S.C. 1721(b)).

The owner of the surveyed land, or a claimant who has purchased from the owner, may apply for the survey as a preliminary to quieting the title. There may or may not be adverse claims. The immediate question is the merit of the application under the Acts of Congress that grant relief in these cases. A field examination is nearly always required to verify the conditions alleged in the applications. In principle, a plat should not be amended unless large and unwarranted discrepancies can be shown.

**8-177.** The survey of erroneously omitted lands may also be undertaken as an administrative responsibility

for identifying Federal interest lands. Such cases may be brought to the attention of the BLM by a Federal agency having administrative authority over the general area or a federally recognized Indian tribe with historical ties to the area.

The need for work of this type will be brought out clearly in the special instructions for the survey or in supplemental special instructions if the facts are developed after the survey has been commenced.

**8-178.** The requirements for making the plats to represent omitted land surveys are outlined in sections 9-108 through 9-113. The plat will carry a memorandum precisely stating the situation with reference to the survey represented, as in the following cases:

The position of the original record-meander courses of the so-called Moon Lake is shown by an irregular line with numbered angle points. This line as thus originally reported was grossly in error, and has therefore been marked as a fixed boundary, with the directions and lengths of the several courses adjusted to the record of the original survey.

The position of the original record-meander courses of Ferry Lake fronting along lot 4, section 9, and lots 2, 3, and 4, section 10, is shown by an irregular line with numbered angle points. This line as thus originally reported was grossly in error, and has therefore been marked as a fixed boundary, with the directions and lengths of the several courses adjusted to the record of the original survey.

The position of the original record-meander courses of a lake reported as having been located in section 36 is shown by an irregular line with numbered angle points. This line as thus originally reported was grossly in error, and, with the exception of certain courses fronting along lots 1, 2, and 9, has therefore been marked as a fixed boundary, with the directions and lengths of the several courses adjusted to the record of the original survey.

This memorandum is in addition to the memorandum referring to the dependent resurvey of the original section lines. The three case studies represented by the memoranda are situations where the survey of erroneously omitted lands has been necessary. An examination of the manner in which each type was

treated should help in determining how to approach similar cases.

See the Chapter VIII Notes for case studies on erroneously omitted lands.

## Accretion Prior To Entry

**8-179.** Occasionally, subsequent to survey, but before entry, claim, or patent, a *large* body of land forms by accretion between the meander line and the OHWM. This special situation falls in the classification of the *Madison v. Basart* (or *Basart*) Doctrine. Under this doctrine, announced in the case *Madison v. Basart*, 59 Interior Dec. 415 (1947), a substantial area equivalent to an omitted lands area is treated as remaining Federal lands and the original meander line is considered to be a fixed and limiting boundary, and entry, claim, or patent is construed to convey only the lands within the meander line.

**8-180.** The lands accreted after survey but before entry are not usually surveyed as would be ordinary accreted lands. Instead, the regular rectangular survey is extended to the body of water. The same procedure would be followed in surveying regular accreted lands only if none of the riparian lots had been alienated and it was desired to extend the survey. If such land had formed *after entry, claim, or patent*, the land would merely attach to the riparian holdings. If all the accreted land had been in place before the survey and remained in place at all times, the land would be considered erroneously omitted lands.

**8-181.** In determining what constitutes a “substantial” accretion, to which the rule in *Madison v. Basart* is applicable, the area of accretion will be compared quantitatively with the riparian lots to which the accretion is attached. Some consideration will also be given to the total area accreted. Accretion to a small lot might be large in proportion but negligible in absolute size. From the standpoint of *size* and *relative size*, the area in question can be weighed as in the case of omitted lands.

An accreted area several times a basic upland lot of small area, say less than 5 acres is not substantial unless the economic value of the area is high and the original entryman, claimant, or patentee certainly would have been aware of the excessively valuable accretions. The substantial accretion exception has not been applied solely on the basis of mere quantitative analysis, but

also upon consideration of the particular equitable factors bearing on unjust enrichment.

See the Chapter VIII Notes for a case study on the *Basart* Doctrine.

## Land Outside Meanders with No Gross Error in Survey

**8-182.** Lands omitted from the original survey lying between the position for the record meander line and the actual bank of a lake, stream, or tidewater, situated in front of Government-owned subdivisions, are subject to survey as public land; although, they may not be of sufficient size and extent to constitute gross error or fraud in the original surveys.

**8-183.** If title to all the subdivisions in a section, shown to be riparian by the plat of the original survey, is still in the United States, and there is no reason for retaining the original lottings, new areas and/or designations may be returned for the Federal land. This procedure ordinarily is not undertaken unless warranted by the values involved, or justified by the difference in area of the subdivisions.

**8-184.** When title to some of the record riparian subdivisions has passed into non-Federal ownership and no claim can be maintained by the United States to the omitted land in front of these subdivisions, partition lines are run and monumented segregating the Federal interest land from the area belonging to the non-Federal owners. Generally, it is necessary to subdivide the sections in the regular manner, reestablish the original meander line, and remeander the body of water. Lot numbers and areas are shown on the official plat for the Federal land being surveyed for the first time.

**8-185.** Where title to all the land in a section based upon the plat of the original survey has passed from the Government, it is not necessary to reestablish the original meander line. This line is protracted upon the survey plat, which should be prepared in the manner similar to the method adopted for showing an area formed by accretion in front of patented lands (figure 9-8). The division lines between patented holdings are not surveyed in the field or shown by protraction upon the plat.

**8-186.** The partition lines between the Federal interest land and nonfederally owned land are run in the

same manner as partition lines dividing areas formed by accretion. The general rule is to follow the method described in *Johnston v. Jones*, 66 U.S. 209 (1862), that is, to apportion the new frontage along the water boundary in the same ratio as that along the line of the record meander course. There are acceptable variations to this rule where local conditions prevail and the added lands are not of great width or extent. In such cases the extension of normal lines to the water boundary is an equitable division to the avoidance of unrealistic or oblique lines that are not commensurate with the considered manner of the land's formation.

See the Chapter VIII Notes for a case study of land outside meanders with no gross error in survey.

## Mineral Lands Survey and Water Boundaries

**8-187.** A surveyed or patented mining claim or site that is described in the field notes and on its plat as abutting on a navigable or other meanderable body of water has the right to remain riparian. The test as to whether the claim or site is riparian requires that the location notice and the field notes describe a meander line not as a boundary of the claim or site but for the purpose of defining the sinuosities of the bank or shore of a body of water. The general rule states that when one of the boundaries of a located or patented mining claim or site is a navigable body of water, all accretions formed after the patent survey date and prior to the patent date of the claim or site passed under the patent, and all accretions that may thereafter form are the property of the riparian proprietor.

**8-188.** An operator of an unpatented mining claim or site has only a revocable license to search for valuable mineral deposits and a right of possession as against other potential mining claimants. Any riparian right is held by the Government as owner of the mineral land.

**8-189.** As a general rule, the subsurface mineral estate beneath riparian areas follows the surface estate during changes in OHWM or line of MHT. When such subsurface mineral estates are severed from the surface estate, the subsurface mineral estate boundary may be fixed as of the date of such severance.

Mineral lands surveys and their relation to water boundaries are discussed further in sections 10-201 through 10-207.

Mineral Leasing Act surveys and their relation to water boundaries are discussed in sections 10-78 through 10-80.

See the Chapter VIII Notes for a case study of water boundary of a lode mining claim.

## Acquired Lands and Tidal Waters

### Resurvey of Acquired Land Uplands and Tidelands Boundaries

**8-190.** Alienated lands to be acquired, or that that have been acquired by the Government, have rights under State law. Any resurvey must be conducted according to the rules establishing such boundaries. Original surveys and meandering of tidelands is discussed in sections 3-202 and 3-203.

**8-191.** In the Supreme Court case *Borax Consolidated v. Los Angeles*, 296 U.S. 10 (1935), the Court addressed the question of the exact boundary between the upland described by a Federal patent and the tidelands. The Court stated the question as to the extent of a Federal grant of land, that is, as to the limit of the land conveyed, or the boundary between the upland and the tideland, is necessarily a Federal question. The case established the rule to be applied in interpretation of the term "line of mean high tide" when construing a Federal grant. The case also established the first precise standard for the demarcation of such boundary on the ground.

The specific instruction was that in determining the limit of a Federal patent the exact line was to be the line of the mean height of all the high tides over a period of one entire lunar cycle of 18.6 years, "as nearly as possible." This value is termed "mean high water." It is identical with the line of MHT.

Thus, in establishing the title boundary along tidelands where the uplands have been alienated or where the boundary is to be determined with requisite certainty and in relation to the value of the lands affected, a method will be chosen to approximate the line of MHT commensurate with the required accuracy identified in the special instructions.

There was no problem in determining such a mean for the *Borax* case because the height had already been determined at the time of the trials; there was a long-term tidal benchmark station near the site.



**8-192.** Where a precise determination of the line of MHT is required, a present time series of tide observations is to be simultaneously observed at the required location and compared with a control tide station in order to derive the equivalent datum of the National Tidal Datum Epoch. Refer to the U.S. Department of Commerce, National Oceanic and Atmospheric Administration (NOAA), National Ocean Service, Computational Techniques for Tidal Datums Handbook (NOAA NOS CO-OPS2), or equivalent, for proper procedures.

**8-193.** Whatever method is used, the final result is an elevation of the line of MHT that is then projected as a mark on the beach surface defining the horizontal position of the proper boundary. These marks are an elevation contour for stretches of uniform beach. However, the height of the tide at any place along the coast varies according to the bathymetry outward from the coast as it interferes with the flow of the tidal wave as it moves back and forth. Nearby but isolated areas of interest may require a separate determination of line of MHT because of the effects of the wind, land mass, and along-shore currents. Unless some physical structure, such as a sea wall, retains the sand on a beach, it is to be expected that the surf will move the beach sands and gravels over time, requiring repeated leveling.

### Survey of Acquired Lands Fronting on a River Near Its Mouth on Tidewater

**8-194.** Consider meanders along the bank of an inland river that empties into a tidewater bay. Along the bay, meanders are run along the line of MHT where that elevation intersects the upland. This location may be evidenced by a certain type of vegetation or escarpment but the boundary is determined by reference to, normally, the elevation of the line of MHT.

Upstream from the bay, the river's surface is still subject to the ebb and flow of the tides, but due to the damming effects of those tides, the river surface will be above the elevation of the line of MHT. In these locations, elevation no longer can be used because of the river's gradient, and the meanders follow the normal inland tests of vegetation and soil.

Above the point of tidal influence, where the daily ebb and flow of the tides no longer affects the river surface elevation, the meanders follow the normal inland tests of vegetation and soil.

The distinction is important because of bed ownership arising from navigability issues. Tidal waters upstream

to the upper point of tidal influence are navigable as a matter of law and, normally, are meandered. Above the point of tidal influence, the river may be navigable as a matter of fact and thus as a matter of law.

## Division of Tidewater Flats

**8-195.** Because the 13 Original States reserved their rights to the tidelands, the Federal Government, when it was formed, did not receive the tidelands. Under the principal of comity, other States that entered the Union also received ownership of the tidelands within their borders. Tidal flats here are intended to describe the area between the line of MHT and extreme low water or extreme lower low water, also defined as the shore space.

A 1641 Massachusetts Colonial Ordinance strongly influenced the laws regarding tidal flats. Under the Massachusetts Ordinance of 1641-1647, the title of the owner of land bounded by tidewater extends from high-water mark over the shore or flats to low-water mark, if not beyond 100 rods (1,650 feet or 25 chains) from high water mark. Grants made to the colony before adoption of the ordinance carried title to the high-water mark only (*Iris v. Town of Hingham*, 303 Mass. 401 (1939)).

The original wording of the Ordinance was as follows in this regard:

“[I]t is declared, that in all creeks, coves and other places about and upon salt water, where the sea ebbs and flows, the proprietor of the land adjoining shall have propriety to the low water mark, where the sea doth not ebb above a hundred rods, and not more wheresoever it ebbs further: provided that such proprietor shall not by this liberty have power to stop or hinder the passage of boats or other vessels in or through any sea, creeks, or coves to other men's houses or lands.”

Most of the special litigation involved disputes over the division lines between adjacent owners of uplands who claimed the flats. Other popular subjects for litigation included determination of whether the shore space was included with the upland deed where the shore space was not specifically mentioned in the deed.

See the Chapter VIII Notes for case studies of division of tidewater flats.



## Protraction Diagrams

**8-196.** Where protraction diagrams show plans of extension of the rectangular system that front potentially meanderable water bodies, the meander lines may be indicated by an irregular line traced from existing map or photographic information. The irregular line is in lieu of a plot of a traverse.

Protraction diagrams are preparatory for a plan of survey and to be able to describe and lease unsurveyed Federal lands. The protraction diagrams are of unsurveyed lands, and all lines, including the meander lines, are calculated from existing records or photography. Where water is segregated, the water area is taken out of the protracted

upland area. The plan of survey protracts but does not determine the meander lines or riparian lots.

A lot shown as riparian by protraction may not be riparian upon survey. Therefore, when it becomes time to survey a township with protracted segregated water bodies the surveyor will not survey the water bodies where protracted but where the water bodies physically are. All surveys of protraction diagrams shall protect bona fide rights as to location.

See sections 3-138 through 3-149 for further discussion on protraction diagrams and amended protraction diagrams.

## Chapter VIII Notes

The notes presented here are case studies that elaborate on or continue to discuss the topics presented in chapter VIII. The section numbers correspond to the section numbers in the chapter and are followed by “(n)” to indicate that they are additional notes. The case studies on pages 225 to 262 and 268 to 272 are used by permission from *River & Lake Boundaries*, by James A. Simpson.

These case studies are provided as training tools, and must be viewed in their historical context. Please be aware that to the extent they refer to case law or legal analyses, such references have been provided in order to explain why certain surveys were conducted in the manner they were. Such case law may, however, have been subsequently superseded and/or may not be applicable outside the particular circumstances and timeframe of that case. Questions in this regard should be directed to the Office of the Solicitor.

### Navigability (Case Studies)

**8-21(n) through 8-56(n).** The following case studies illustrate some of the various legal settings in which navigability is an issue. Whether the case centered around the issue of title to land, commerce, or admiralty jurisdiction, the Supreme Court has pointed out that the words defining navigability are the same but the application and the result are very different in each application. Surveyors need to be aware of these situations, which may affect their resurvey work.

#### *United States v. Holt State Bank*, 270 U.S. 49 (1926)



Figure 8-41. Vicinity map.

This case centered on the issue of title to land. Mud Lake in Minnesota was claimed by the United States to have been a marsh covering about 5,000 acres at the date of Minnesota’s statehood. The United States claimed that the GLO surveyors should have extended the survey across the “lake,” breaking it up into sections for sale. This case is helpful in determining navigability of a lake that had been drained or was difficult to navigate at time of statehood.

The Court found that in its natural condition the lake area was traversed by Mud River, a tributary of the Thief River, a navigable river leading into Canada. Mud Lake was formerly part of the Red Lake Indian Reservation for Chippewa Indians. Most of the reservation was ceded back to the United States and surveyed for sale after classification as “agricultural” lands or “pine” lands.

After the survey, classification and sale, patents around Mud Lake were issued.

Under a combination of Federal and Minnesota laws, a project to drain the lake was undertaken. By 1912 it was completely drained by a ditch that passed through the “lake” and emptied into the Thief River (figure 8-42). The United States claimed ownership and proposed to survey the former lake bed and sell the land for the benefit of the Chippewa Tribe.

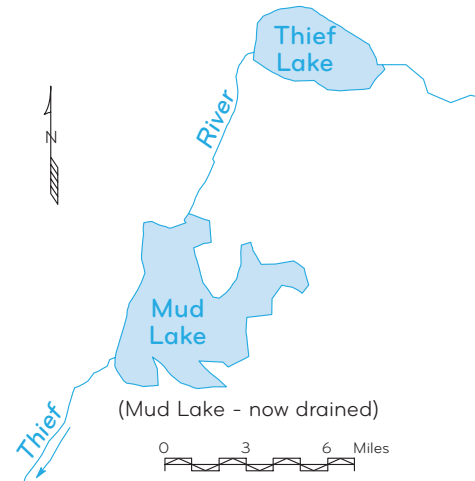


Figure 8-42. Mud Lake vicinity.

The State claimed the lake had been navigable and that it had become owner of the now-drained lakebed. Because Minnesota had granted the beds of navigable waters to the adjoining upland owners, the State claimed that the surrounding patented landowners became owners of the lakebed.

The State courts using Minnesota law standards found for the defendant, Holt State Bank, on the basis that the lake had been navigable. The United States appealed.

From the U.S. Supreme Court decision: “Navigability, when asserted as the basis of a right arising under the Constitution of the United States, is necessarily a question of federal law . . . .” (p. 55.)

Farther down the Court states: “But notwithstanding the error below in accepting a wrong standard of navigability, the findings must stand if the record shows that according to the right standard the lake was navigable.” (p. 56.)

Although lengthy, the Court’s description of the river conditions is worthy of study and it follows:

In its natural and ordinary condition the lake was from three to six feet deep. When meandered in 1892 and when first known by

some of the witnesses it was an open body of clear water. Mud River traversed it in such way that it might well be characterized as an enlarged section of that stream. Early visitors and settlers in that vicinity used the river and lake as a route of travel, employing the small boats of the period for the purpose. The country about had been part of the bed of the glacial Lake Agassiz and was still swampy, so that waterways were the only dependable routes for trade and travel. Mud River after passing through the lake connected at Thief River with a navigable route extending westward to the Red River of the North and then northward into the British possessions. Merchants in the settlements at Liner and Grygla, which were several miles up Mud River from the lake, used the river and lake in sending for and bringing in their supplies. True, the navigation was limited, but this was because trade and travel in that vicinity were limited. In seasons of great drought there was difficulty in getting boats up the river and through the lake, but this was exceptional, the usual conditions being as just stated. Sand bars in some parts of the lake prevented boats from moving readily all over it, but the bars could be avoided by keeping the boats in the deeper parts or channels. Some years after the lake was meandered, vegetation such as grows in water got a footing in the lake and gradually came to impede the movement of boats at the end of each growing season, but offered little interference at other times. Gasoline motor boats were used in surveying and marking the line of the intended ditch through the lake and the ditch was excavated with floating dredges. (p. 56.)

Our conclusion is that the evidence requires a finding that the lake was navigable . . . (p. 57.)

According to the United States' claim was denied and under State law the former bed of the navigable lake passed to the adjoining upland owners.

The final conclusion that the ditch was excavated with floating dredges may not necessarily be a valid indicator. See *U.S. v. Crow, Pope & Land Enterprises, Inc.*, 340 F.Supp. 25, 35 (1972) where the "isolated and exceptional example of a person using the river for a few miles primarily along his own property, to extract gold-bearing silt from the river bed" was insufficient to demonstrate navigability.

***United States v. Appalachian Electric Power Co.*,  
311 U.S. 377 (1940), *reh'g denied*, 312 U.S. 712 (1941)**

This case centered on the issue of the Commerce Clause and decided whether the bed of New River in Virginia and West Virginia was a navigable water of the



Figure 8-43. Vicinity map.

United States. The Appellate Court held that navigability in fact must exist under natural and ordinary conditions rather than by human-made improvements. We study this case because the effect of improvements must be considered in all navigability questions.

Appalachian Power had obtained a license from the State of Virginia to construct a dam in New River at a point just upstream from the town of Radford.

The dispute started when Appalachian Power proceeded to build the dam under the State of Virginia license only.

The Federal Power Commission and the U.S. Corps of Engineers (The Corps of Engineers was charged with administration of navigation permits) claimed the dam would have an adverse effect on navigation of the Kanawha River many miles downstream. New River was a principal tributary of the Kanawha (figure 8-44). The Government filed suit in Federal District Court in Virginia (23 F.Supp. 83 (1938)).



Figure 8-44. New River flows to the Kanawha River and then to the Ohio River.

The Government asked the Court to stop the construction and require the work be removed because New River was a navigable water of the United States.

Appalachian Power claimed New River in the vicinity of the dam site was not navigable and that it owned all the land where the dam was to be built; also that the State of Virginia controlled such construction on non-navigable streams.

Whether the entire length of New River from the proposed dam down to the Kanawha was navigable became the final issue at trial.

The District Court decision contains a very detailed description of the river's hydrology, hydraulics, geography and geology. A substantial amount of evidence was entered on these subjects.

The Government contended in the trial that New River and Kanawha River was really all one long river and that because the Kanawha was concededly navigable, therefore the entire river was navigable. The District Court rejected that claim, saying that if that were true, all mountain brooks and rivulets would then need to be classed as navigable.

The Government also claimed that both the State and Federal governments had always treated New River as a navigable river. The Court rejected that claim also, quoting a 1912 report from the Chief of (Army) Engineers. The conclusion quoted was that New River "could not be connected with navigation in the Kanawha by the expenditure of any reasonable amount [of money]."

The Government claimed New River had been used in the past for movement of substantial amounts of commerce between the States of Virginia and West Virginia. Also they claimed it was susceptible to such use.

The District Judge ruled that the reach between head of navigation of the Kanawha (at Kanawha Falls) and the town of Hinton was steep and obviously not practicably susceptible for navigation. Some schemes for building a canal in the 1870s never materialized.

The District Court decision alludes to much evidence on navigability concerning the reach above Hinton to a point above the proposed dam site near Radford, Virginia. The types of evidence are worthy of study from the lower court's decision.

The Judge stated that the question of navigability is one of fact to be determined from evidence. The Judge had

allowed witnesses to express opinions as to the navigability but that the final decision in the trial was his alone.

The District Court's finding of fact was that "there is at present no commerce or navigation on New River or, if any, it is entirely local and in a trivial and unnoticeable amount; that the Federal Government has made no improvements on the river since those heretofore discussed and that it does not have in contemplation any improvements affecting the navigable condition." (p. 98).

The finding of local or trivial use in commerce was in spite of the testimony of use of the river above Radford by keelboats of 2- to 4-foot draft. They had been used in hauling ores and supplies. A gasoline powered boat was described that drew 12 inches of water when loaded. It had been used in the river near Radford.

The District Court thus refused to stop the construction.

Appeals were taken to the Circuit Court of Appeals and thence to the Supreme Court of the United States.

The Supreme Court divided the river into three reaches according to the general topography contained. The lower reach was from the town of Hinton up as far as Wylie Falls. Some improvements to this stretch had been made in aid of navigation during the years 1876 to 1883. The middle reach was from Wylie Falls to Radford, a 59-mile stretch. That reach had never been improved in aid of navigation except at the Wylie Falls vicinity. The upper reach was from Radford to the town of Allisonia, which had also been improved by the United States during the 1876 to 1883 period (figure 8-45).

The U.S. Supreme Court found that the evidence of navigability for the upper and lower reach was more convincing than that of the middle reach. Their opinion was, then, to be directed to the middle reach primarily.

The decision describes the use of keel boats and the difficulties of navigating New River between these points. A railroad was built in the 1880s that paralleled the river. Following the coming of the railroad, the use of the river in commerce practically ceased.

The Supreme Court said, in part:

Use of a stream long abandoned by water commerce is difficult to prove by abundant



Figure 8-45. Reach designations of New River.

evidence. Fourteen authenticated instances of use in a century and a half by explorers and trappers, coupled with general historical references to the river as a water route for the early fur traders and their supplies in pirogues and Durham or flat-bottomed craft similar to the keelboats of the New River had been found adequate for proof of navigability in an earlier case, *Economy Light and Power Company v. United States*, 256 F. 792 (1919), *aff'd*, 256 U.S. 113 (1921).

Thus, the Supreme Court concluded that the Wylie Falls to Radford stretch, as well as the lower and upper reaches, were navigable waters of the United States. The right to build the dam would thus necessarily be subject to U.S. Corps of Engineers regulations.

Perhaps the most important finding by the Court was that a waterway that by reasonable improvement can be made available for navigation in interstate commerce is

a navigable water of the United States, provided there be a balance between cost and need at a time when the improvement is needed.

The fact that there is a dam now in place at a point above the town of Radford and there is a sizable reservoir above it indicates the eventual use of the site. Presumably the power company was required to obtain a Federal license and to comply with Corps of Engineers requirements in order to continue construction.

#### *United States v. Ross*, 74 F.Supp. 6 (E.D. Md. 1947)



Figure 8-46. Vicinity map.

This case centered on the issue of jurisdiction for admiralty purposes. The U.S. Attorney wanted to prosecute Howard Ross. In order to make the charge stick, the crime had to have been committed on navigable waters of the United States. We take up this case because it shows how the courts have considered small but deep channels alongside a navigable river to be nonnavigable. Contrast this case with *Packer v. Bird*, 137 U.S. 661 (1891).

Howard Ross was charged with reckless operation of a boat in violation of a Federal law. The incident occurred in a borrow pit alongside a levee on the Missouri side of the Mississippi River. The borrow pit was filled with river water at the time. Ross had loaded his boat with 10 hunters and, when it sank, three passengers drowned.

Because there was a 3-foot deep waterway connection to the Mississippi River and because the water was 6 to 7 feet deep, the Government contended the borrow pit was a navigable water of the United States (figure 8-47). The only evidence of use of the borrow pit for commerce was that Howard Ross provided duck hunters with an informal ferry service to the hunting on the levee banks. This only occurred during hunting season. During dry spells the opening to the Mississippi dried up and motorboats could not operate in the borrow pit.

The Court found that this was not evidence of use in interstate commerce and that, "Mere depth of water, without profitable utility, will not render a water course navigable in the legal sense," quoting *Harrison v. Fite*, 148 F. 781 (1906). The borrow pit was held to be non-navigable (p. 9).

Remember that this trial considered navigability as affecting application of Federal criminal jurisdiction, which is based on the requirement of interstate commerce.



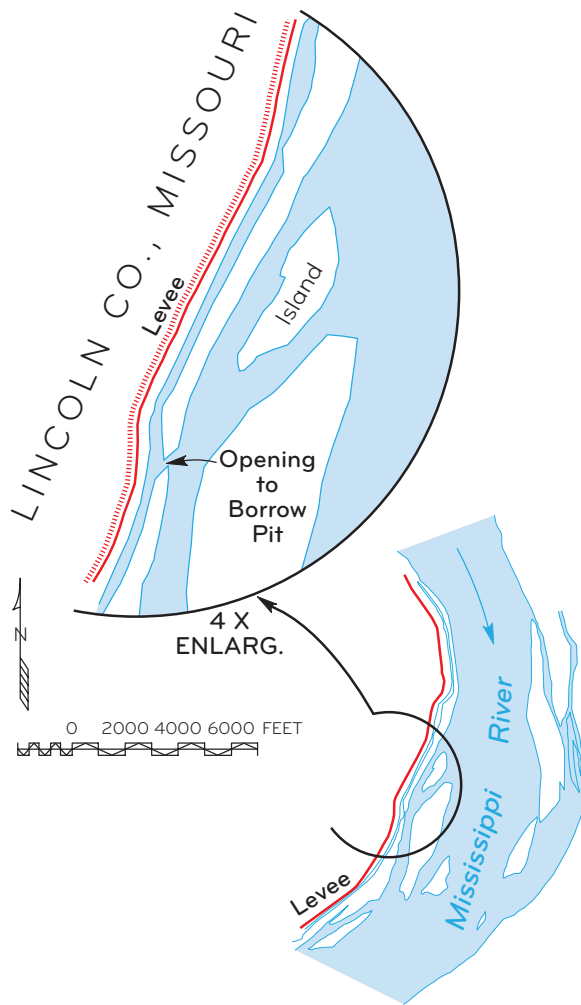


Figure 8-47. Vicinity map for the Ross case on the Mississippi River.

***Minnehaha Creek v. Corps of Engineers***, 449 F.Supp. 876 (1978), *aff'd in part & rev'd in part*, 597 F.2d 617 (1979)



Figure 8-48. Vicinity map.

This case centered on the issue of the Commerce Clause. It concerned the navigability of Lake Minnetonka and Minnehaha Creek in Minnesota among other issues. Navigability claimed by the Corps of Engineers was disputed. If the waters were classed as “navigable waters of the United States” local owners were required to get a permit from the

U.S. Corps of Engineers for any construction involving the bed of the lake or stream (figure 8-49).

Findings of fact by the Court relating to navigability were:

(1) Lake Minnetonka’s water levels were controlled by a fixed crest dam constructed in 1852. The depth of the lake averages 40 feet with some depths up to 100 feet. Minnehaha Creek is the lake’s single outlet.

(2) Minnehaha Creek flows into the Mississippi some 20 miles from the lake outlet. Flow is variable and intermittent. During the summer and fall there is not enough depth for any form of navigation.

(3) There is no history of navigation, private or commercial, on Minnehaha Creek.

(4) The history of navigation on Lake Minnetonka included canoe travel prior to settlement. After the dam raised the lake level, steam powered boats used the lake as well as log rafts.

Luxury steamboats operated on the lake from Civil War times until 1926. After 1867 steamers carried rail passengers from a railroad at Wayzata across the lake to Excelsior, a major town on the lake shore. Mail was carried by boat to Minnehaha Creek and thence by horse-drawn stage to other points.

Grain and lumber products were carried to mills and shipped by rail from that point on.

(5) In 1916 the Corps of Engineers had advised a railroad company that their permit was required for construction of a bridge across an arm of Lake Minnetonka. No other action by the U.S. Corps of Engineers had exercised any authority over the lake from 1916 until 1945.

(6) In 1945 the U.S. Corps of Engineers advised the State of Minnesota that Minnehaha Creek was navigable and the State had treated the stream in that manner since 1945.

(7) The 1976 use of the lake was limited to recreational use by small boats, except that three excursion boats carried passengers for hire and several marinas rented out boats for recreation.

(8) The St. Paul District of the Corps of Engineers issued a report in 1975 declaring Lake Minnetonka and Minnehaha Creek to be navigable waters of the United States.

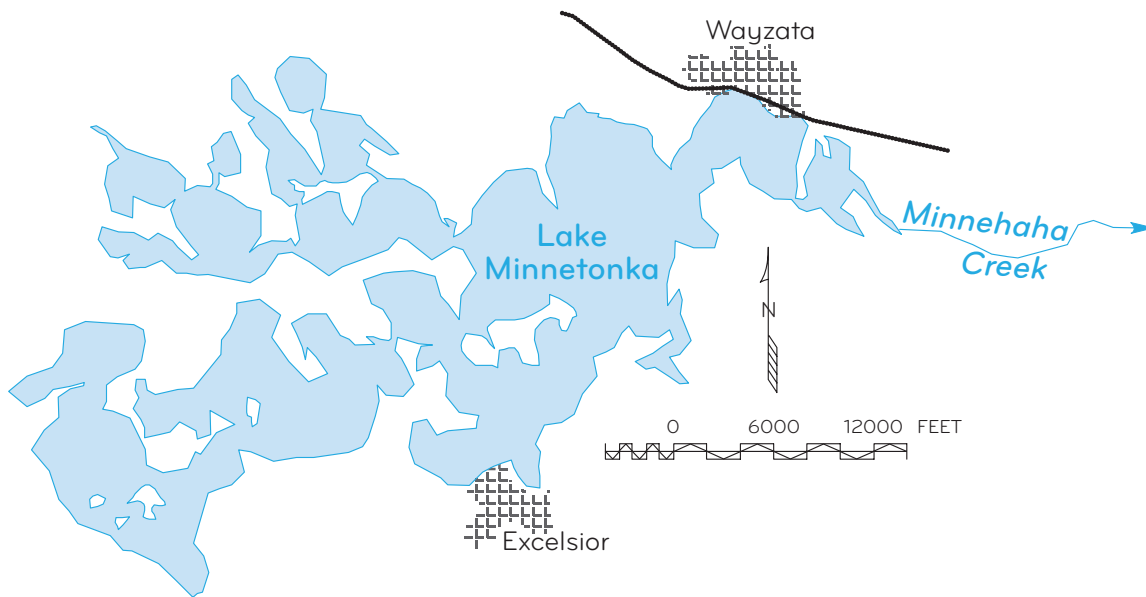


Figure 8-49. Lake Minnetonka vicinity.

The Corp's claim was not based on Lake Minnetonka and Minnehaha Creek being a part of a channel that formed an interstate waterway. Instead they claimed that the waters were used for interstate commerce through railroad and other forms of commercial transportation.

The first thing the Court did was to rule that the Corp's finding of navigability was not binding on the Court; the determination would be made from examination of evidence only.

Quoting *Economy Light and Power Co. v. United States*, 256 U.S. 113 (1921), the Court agreed that navigability in law is not destroyed just because the watercourse is interrupted by occasional natural obstructions. Also, a river that has not been used for navigation for over 100 years is still considered navigable for Federal regulatory purposes. Further, a water body that can be made navigable by reasonable improvement could be considered navigable.

However, the ruling was that the navigability had to be based on use in interstate commerce as a link to other navigable waters. The Court cited a case on the Great Salt Lake (obviously navigable) where use in interstate commerce was denied although salt was carried by barges to a railroad siding for shipment to other points, which could have been out of State (*Hardy Salt v. Southern Pacific*, 501 F.2d 1156 (1974)).

Because Minnehaha Creek was never part of any link in interstate commerce—via the Mississippi for

instance—Lake Minnetonka was not part of the navigable waters of the United States. The lake would remain navigable under the State's waters test, it is believed.

***United States v. Utah***, No. 14 Original; 283 U.S. 64 (1931)

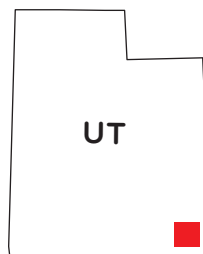


Figure 8-50. Vicinity map.

This case concerned title to the beds of the Green River, the Grand River and the Colorado River within the State of Utah. What was then called the Grand River is now named as part of the Colorado River in the States of Utah and Colorado (figure 8-51).

This case is particularly important to us because it sets out clearly that a river need not be navigable in all of its reaches. The same river can be not navigable in part mixed in with navigable stretches. The case also sets out that the susceptibility or capability for navigation at the time of statehood must also be considered.

The United States, as owner of the uplands in Canyon Lands National Park and of other public lands, had issued oil and gas prospecting permits on areas covered by the beds of these rivers under the assumption that these rivers were not navigable and the beds belonged to the United States. The United States claimed that it acquired the land from Mexico and its title included the

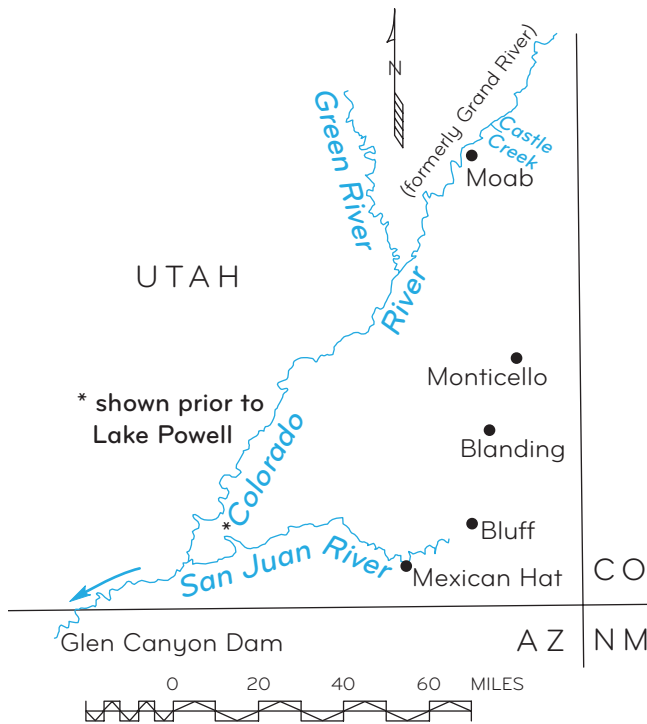


Figure 8-51. The Colorado River in Utah.

beds of all the rivers except where recognized grants existed.

Utah, claiming the rivers were navigable, has issued and delivered oil and gas leases covering the same areas of the river beds.

The question of navigability was not tried to determine whether the waters were “navigable waters of the United States” presumably because there was no claim of usage of the river in interstate commerce.

Whether the waters were “navigable waters of the State of Utah” was the question.

A Special Master tried the case and found that some reaches were navigable and some were not navigable. Both parties disagreed with the findings.

The U.S. Supreme Court stated the primary question thus:

The question here is not with respect to a short interruption of navigability in a stream otherwise navigable, or of a negligible part, which boats may use, of a stream otherwise non-navigable. We are concerned with long reaches with particular characteristics of navigability or

non-navigability, which the Master’s report fully describes. (p. 77.)

The Court described each of the rivers: “The question of that susceptibility [of use in commerce] in the ordinary condition of the rivers, rather than of the mere manner or extent of actual use, is the crucial question.” (p. 82.)

And later:

The extent of existing commerce is not the test. The evidence of the actual use of streams, and especially of extensive and continued use for commercial purposes, may be most persuasive, but where conditions of exploration and settlement explain the infrequency or limited nature of such use, the susceptibility to use as a highway of commerce may still be satisfactorily proved. (p. 82.)

And still later:

Utah, with its equality of right as a state of the Union, is not to be denied title to the beds of such of its rivers as were navigable in fact at the time of the admission of the state either because the location of the rivers and the circumstances of the exploration and settlement of the country through which they flowed had made recourse to navigation a late adventure, or because commercial utilization on a large scale awaits future demands. (p. 83.)

With regard to sand bars, the U.S. Supreme Court describes the difficulties of navigation where crossing bars and rapids are present. It also referred to the known difficulties of navigation of the Missouri and the Mississippi River because of sand bars. With that it ruled, however, that “the river is navigable in fact, although its navigation may be encompassed with difficulties by reason of natural barriers such as rapids and sandbars.” (p. 86.)

Of some importance also is that one of Utah’s exceptions to the Special Master’s report was that a 4.35-mile stretch of river just below the junction of the Green and the Colorado Rivers was considered nonnavigable along with the next reach which was agreed to be non-navigable. Utah pointed out that there was more water available in the 4.35 miles because of the combined flow and that there were no more difficulties in navigation than in the Colorado above the junction. The U.S.

Government did not present facts to refute the challenge and the Court made the change in the point of differentiation, subject to precise determination of the point where it became nonnavigable.

**Oklahoma v. Texas**, No. 20 Original; 258 U.S. 574 (1922)



Figure 8-52. Vicinity map.

A series of cases of the Supreme Court resulting in 19 opinions and 33 decrees address the boundary between Texas and Oklahoma along the bed of the Red River. The segment of the bed of the Red River from the 100<sup>th</sup> to the 96<sup>th</sup> meridian is the most thoroughly surveyed and litigated riverbed in the history of the United States. The Court found that the Red River bed was a braided stream that ranged in width from 3 to 15 miles. Eventually it was decided that the boundary between Texas and Oklahoma was along the right bank of the Red River when it is full but not in flood. The Court undertook the determination of navigability under the Property Clause and all of the facts in the bed of the river and its history that border on that answer.

A very important point made by the Court was that the river must be suitable for commercial navigation for a majority of the year. Seasonal rises in the river due to spring and fall rains that lasted only a few weeks were not sufficient to make a river navigable under the Property Clause even though commercial navigation sometimes occurred during those temporary rises.

The Court found the Red River to be nonnavigable; therefore, Oklahoma and its riparian owners only

owned half of the riverbed extending from the left bank. Since Texas could have no ownership outside its boundary, the United States owned the half of the bed measured from the right bank, i.e., unsurveyed public domain land.

### Avulsion and Boundaries (Case Studies)

**8-57(n) through 8-107(n).** The following case studies illustrate some of the various legal settings in which avulsion is an issue. Surveyors need to be aware of these situations, which may affect their resurvey work.

**Nebraska v. Iowa**, No.4 Original; 143 U.S. 359 (1892)



Figure 8-53. Vicinity map.

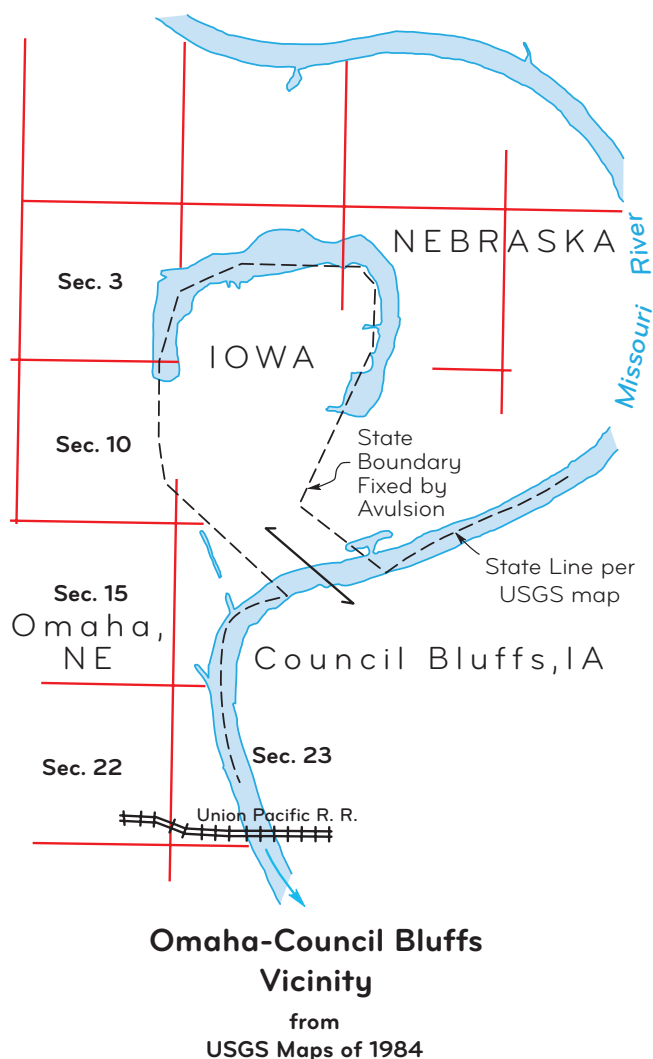
The State of Nebraska claimed that the soil along the Missouri River was so sandy, and avulsive changes in

channel occurred so often, that the common law rule of avulsion should not apply. Immediately above Omaha, Nebraska, an oxbow bend was created rapidly by the river and then cut through by an avulsion; Nebraska claimed Iowa should not get to keep the island left behind (figure 8-54).

This case is among those of the most important to surveyors because here the U.S. Supreme Court distinguished between rapid erosion and an avulsion. The Court determined that rapid erosion and accretion was not the legal equivalent of avulsion. The Court also defined an avulsion in clearly understandable terms, especially where areas of river bank have been alleged to cave off into the river during flood.

The U.S. Supreme Court quoted at length from international legal authorities that universally applied the avulsion concept between sovereigns. Significantly, the Court defined an avulsion as “where a stream, which is a boundary, from any cause suddenly abandons its old and seeks a new bed, such change of channel [termed avulsion] works no change of boundary; and that the boundary remains as it was, in the center of the old channel, although no water may be flowing therein.” (p. 360.)

Nebraska contended that in the normal course of events along the Missouri River, great slabs of soil and trees would fall into the river during high water



**Figure 8-54.** Before the avulsion, the river formed a tight loop back to the north. When the breakthrough occurred, the old channel remained as a remnant lake.

times, a common happening during a classic avulsion. Nebraska claimed that because it was a normal event such an application of the avulsion rule would not be practical and the avulsion rule should not apply.

Quoting from the decision:

The Missouri River is a winding stream, coursing through a valley of varying width, the substratum of whose soil, a deposit of distant centuries, is largely of quicksand. In building the bridge of the Union Pacific Railway Company across the Missouri River, in the vicinity of the tracts in controversy, the builders went down to the solid rock, sixty-five feet below the surface, and there found a pine log a foot and a half in diameter—of course a deposit made in the long ago. The current is

rapid, far above the average of ordinary rivers; and by reason of the snows in the mountains there are two well known rises in the volume of its waters, known as the April and June rises. The large volume of water pouring down at the time of these rises, with the rapidity of its current, has great and rapid action upon the loose soil of its banks. Whenever it impinges with direct attack upon the bank at a bend of the stream, and that bank is of the loose sand obtaining in the valley of the Missouri, it is not strange that the abrasion and washing away is rapid and great. Frequently, where above the loose substratum of sand there is a deposit of comparatively solid soil, the washing out of the underlying sand causes an instantaneous fall of quite a length and breadth of the superstratum of soil into the river; so that it may, in one sense of the term, be said that the diminution of the banks is not gradual and imperceptible, but sudden and visible. Notwithstanding this, two things must be borne in mind, familiar to all dwellers on the banks of the Missouri river, and disclosed by the testimony: that, while there may be an instantaneous and obvious dropping into the river of quite a portion of its banks, such portion is not carried down the stream as a solid and compact mass, but disintegrates and separates into particles of earth borne onward by the flowing water, and giving to the stream that color which, in the history of the country, has made it known as the “muddy” Missouri; and, also, that while the disappearance, by reason of this process, of a mass of bank may be sudden and obvious, there is no transfer of such a solid body of earth to the opposite shore, or anything like an instantaneous and visible creation of a bank on that shore. (p. 368.)

Later the Court continued: “The only thing which distinguishes this river from other streams, in the matter of accretion, is in the rapidity of the change caused by the velocity of the current; and this in itself . . . works no change in the principle underlying the rule of law in respect thereto.” (p. 369.)

The Court rejected Nebraska’s argument and held that the rule of avulsion applies on the Missouri River and that the abandonment of an ox-bow channel caused the boundary to be fixed in its former position.

The Court held that avulsive changes in boundary rivers between States leave the former boundary fixed.



*Arkansas v. Tennessee*, No. 4 Original; 246 U. S. 158 (1918)

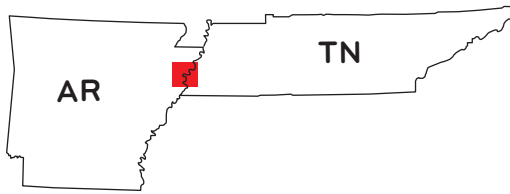


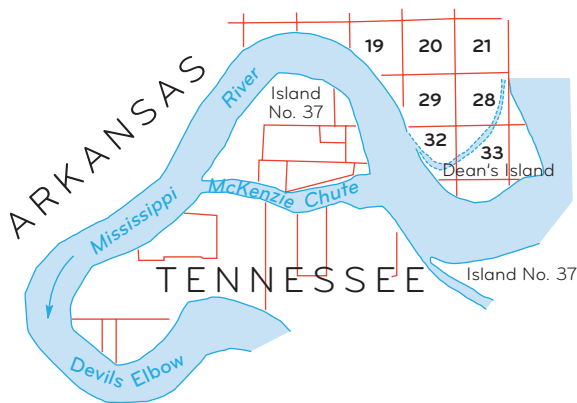
Figure 8-55. Vicinity map.

Following an 1876 avulsion of the Mississippi River, both Arkansas and Tennessee agreed that the prior boundaries became fixed but Tennessee claimed the middle of the river should be used according to the original 1823 meanders. Arkansas claimed that all erosion and accretion between 1823 and the time the avulsion was complete should belong to Arkansas. As shown by the original surveys of 1823, the Mississippi River had a channel averaging about a mile in width and, in the contested area, formed a large loop nearly 20 miles long (figure 8-56).

This case is included for study because the U.S. Supreme Court defined the completion of an avulsive change, especially as it concerns the time at which the abandoned channel becomes a fixed boundary.

Subsequently, the river continued to erode down valley and outward in places (figure 8-57).

By 1876 the river had eroded down-valley and outward in places such that the river broke through in a classic



**1823 Original Surveys**  
from  
**Humphreys' Map of 1904**

Figure 8-56. By the early 1800s, a 9-mile-long loop had formed in the Mississippi River.

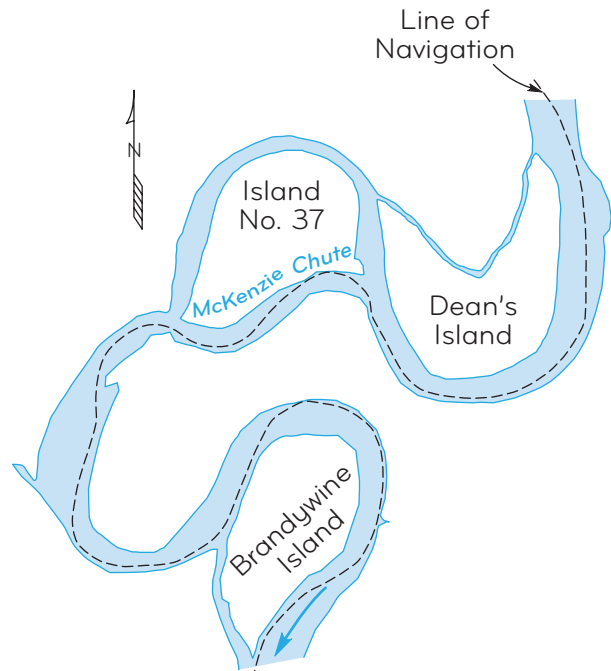


Figure 8-57. An 1874 map shows a large peninsula of Tennessee between the river loops at Dean's Island and Brandywine Point. Subsequently, Centennial Cut severed the peninsula.

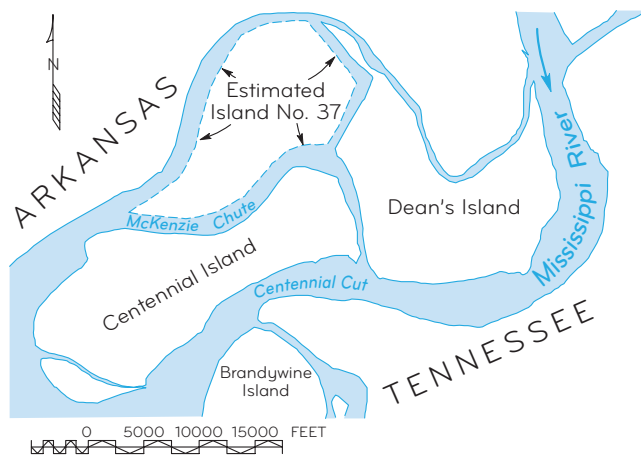
avulsion, short circuiting the 20-mile loop. Within 60 hours the river had widened the new breakthrough to about a mile wide and 40 to 50 feet deep. Barns and houses fell into the new channel so quickly that people could not rescue their household goods in some cases. Two thousand acres of cultivated land were eroded in that 60 hours, or about 33 acres per hour.

The avulsive cutoff was called the Centennial Cut because it coincided with the 100<sup>th</sup> anniversary of the Declaration of Independence.

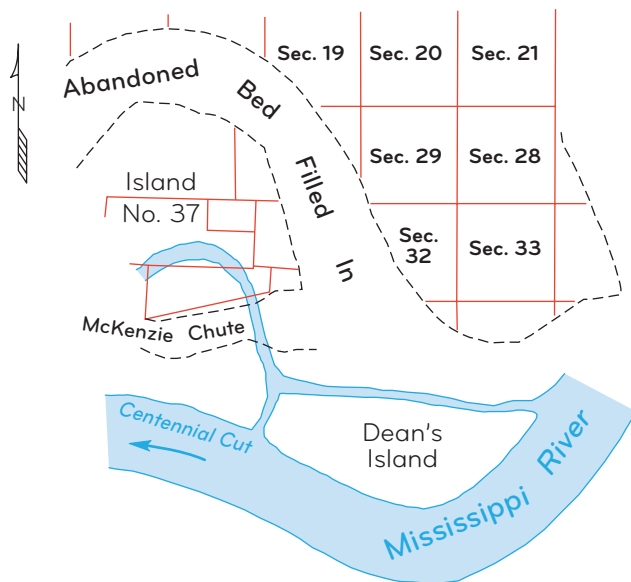
For 3 or 4 years after the avulsion, the old channels remained navigable for small boats only. By 1880 the old beds were substantially dry except during floods. The drying up was caused by sediment deposited by the river, mainly in the upstream end of the old channel.

A map by the Mississippi River Commission in 1883 shows the condition after the avulsion, except that Island No. 37 appeared as a blank space on the Commission's map (figure 8-58).

As the upper parts of the abandoned bed filled in with sediments, the old bed became usable for agriculture and was suddenly valuable (figure 8-59). Most of those valuable additions were benefiting the owners on the Arkansas side of the abandoned bed because of the way the deposits formed.



**Figure 8-58.** Maps from 1883 show Centennial Island has been isolated by an avulsion. The island remained in Tennessee under the principles of avulsion.



**Figure 8-59.** By 1904, the abandoned bed had filled in to become valuable farm land.

Tennessee and Arkansas each formed a commission to decide on the boundary location. The respective commissions did not agree.

Tennessee claimed that the boundary should be fixed at the middle of the abandoned channel as defined by the original 1823 surveys. Tennessee also claimed that the owners of the banks and the bed should be restored to their lands according to the 1823 original boundaries. A Tennessee Supreme Court Decision even ruled that way. *State v. Muncie Pulp Co.*, 119 Tenn. 47 (1907) *rev'd*, *Cissna v. Tennessee*, 246 U.S. 289 (1918). Tennessee additionally claimed that because there was no reason for navigation in the old channel after the

avulsion that the thalweg should be abandoned after an avulsion and not used as a boundary.

Arkansas, on the other hand, contended that the dividing line should be exactly where the middle of the navigable channel was at the time of the avulsion. Also, it claimed, each owner should get to keep accretions that had occurred up to the time of the avulsion.

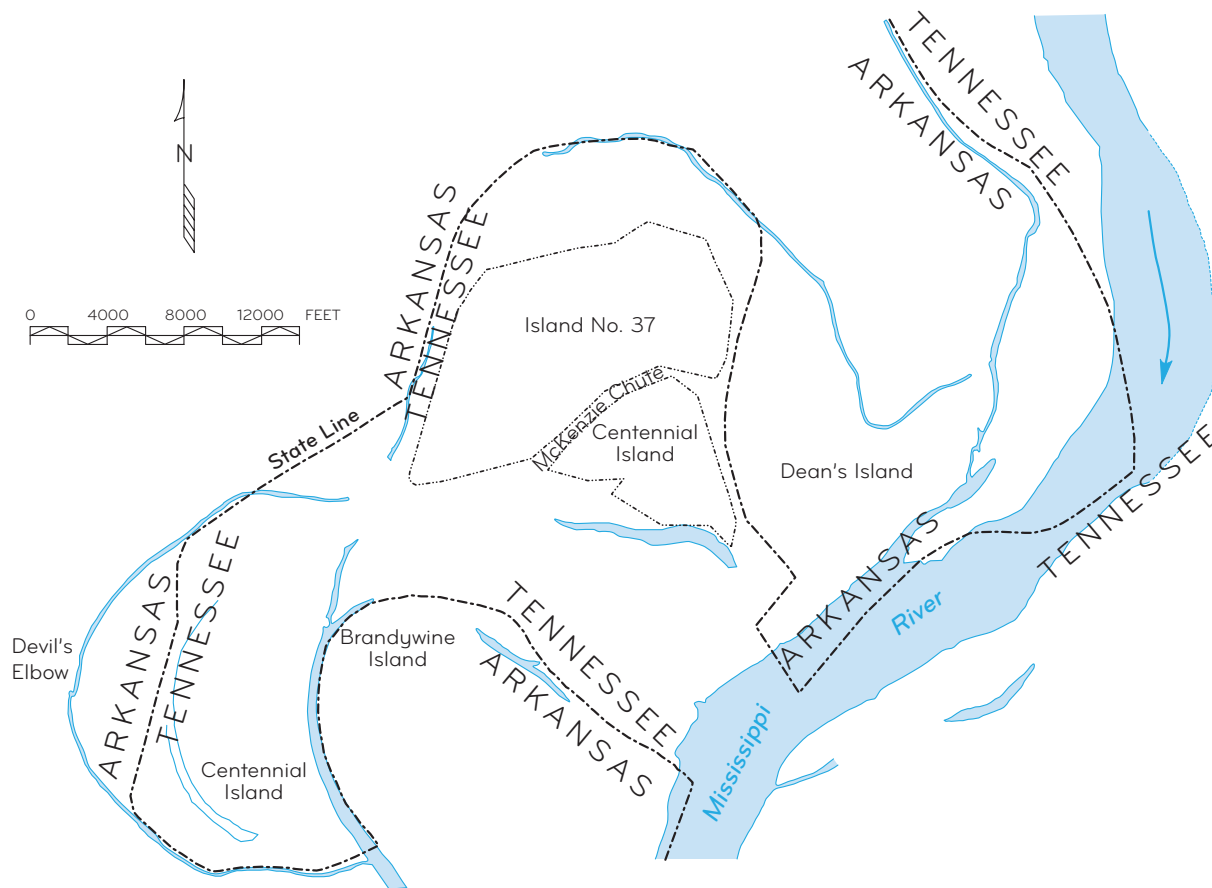
The U.S. Supreme Court affirmed that the boundary between two States was at the “middle of the navigable channel” and not between the middle of the banks at normal water nor between the meander lines.

The U.S. Supreme Court also affirmed the legal principles of avulsion and cited their previous language in *Nebraska v. Iowa*, above, defining avulsion as “if the stream from any cause, natural or artificial, suddenly leaves its old bed [and] forms a new one, by the process known as an avulsion, the resulting change of channel works no change of boundary.” (p. 173).

The Court also discussed the “doctrine of submergence and reappearance of land” and held that, where the record riparian parcel has been submerged and then subsequently reemerges through a subsidence of the water such that the same soil is exposed, title is in the record riparian parcel owner, rather than the remote parcel owner. The doctrine is an exception to the rule of accretion. It rests on the easy identification of the same identifiable soil that has reemerged. In any event, the doctrine of “re-emergence” is not applicable where land has eroded away and then been restored through the process of accretion.

Most importantly, the Court ruled that as long as the abandoned channel remains a running stream, erosion and accretion still apply, “but when the water becomes stagnant, the effect of these processes [erosion and accretion] is at an end; the boundary then becomes fixed in the middle of the channel . . . and the gradual filling up of the bed that ensues is not to be treated as an accretion to the shores but as an ultimate effect of the avulsion” (p. 175).

As to how the property on each side of the abandoned bed is to be allocated between the State, as owner of the bed, and the upland proprietor was to be determined by the law of each State. “Arkansas may limit riparian ownership [upon navigable streams] by the ordinary high-water mark; and Tennessee, while extending riparian ownership upon navigable streams to ordinary low-water mark, and reserving as public the lands

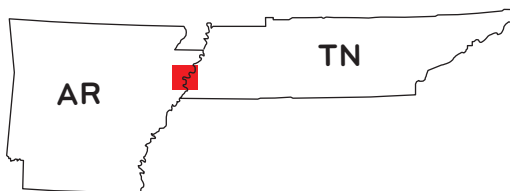


**Figure 8-60.** The Mississippi River from 1970 USGS mapping. The river is now straightened, leaving the former islands attached to the Arkansas mainland.

constituting the bed below that mark . . . may . . . recognize [prior ownerships.]” (citations omitted) (p. 176).

Finally the Court appointed a commission to locate the boundary line between the States at the middle of the channel as it was at the time the current ceased to flow as a result of the avulsion. Centennial Island thus remained as part of Tennessee (figure 8-60).

***Uhlhorn v. U.S. Gypsum Company***, 366 F.2d. 211 (8<sup>th</sup> Cir. 1966), *cert. denied*, 385 U.S. 1026 (1967)



**Figure 8-61.** Vicinity map.

In the same locality as *Arkansas v. Tennessee*, this case involved a change of channel where the “island” formed was 4 feet below the OHWM of the river. Mrs. Uhlhorn claimed to own an “island,” or towhead, which was the disputed area. The Massey Towhead was located off

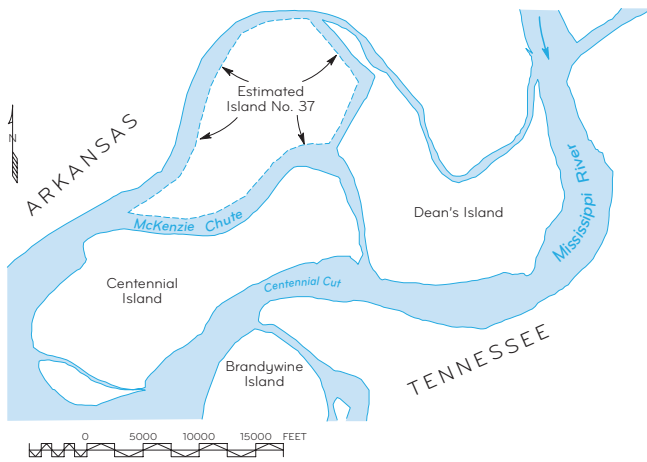
Brandywine Island as shown on the maps of the case immediately above. If avulsion applied, the State boundary would not move to the newer and dredged channel. If the State line moved, she could have an earlier trial thrown out for want of jurisdiction.

The case is important to us because the facts describe an artificial channel change that took place within the bed of the river and in a suit between private landowners whose common boundary was a State boundary. The Court’s final ruling accepted the change as an avulsion.

Referring to *Arkansas v. Tennessee*, recall that after the river avulsed Centennial Island was on the right bank of the river but remained a part of Tennessee. Also, Brandywine Island as shown on the 1883 map was now on the left bank of the river but remained a part of Arkansas (figure 8-62).

The river bend that curved around Brandywine Island was known as the Bendway Channel.

Between the time of the 1883 map and the 1920s the river in the Bendway Channel had been moving



**Figure 8-62.** The 1883 map from the *Arkansas v. Tennessee* case is repeated for reference.

northwesterly, eroding into Centennial Island and accreting to Brandywine Island (figure 8-63). Also, a towhead built up naturally along the point of the Bendway Channel. (A towhead is defined as an alluvial obstruction in a river.)

Because the Bendway Channel was becoming increasingly curved, the sharp bend required tugs to uncouple barges to navigate them around the curve. To alleviate that condition the U.S. Corps of Engineers began dredging in the early 1930s. Dredge spoil was added to the towhead by the U.S. Corps of Engineers' operations.

In 1933 the Engineers opened a new channel across Massey Bar, the point bar on Brandywine Island. The new channel was between Massey Towhead and

Brandywine Island. Because the channel was across the bar, and because the towhead was below the OHWM, the Corps could do this under the navigable (navigational) servitude doctrine without purchasing the property.

Some dredging was continued in the old Bendway Channel as well as in the new Pointway Channel as it was called.

The Engineers attempted to forcibly change the main river flow to the Pointway Channel. They pumped the dredge spoil from the Pointway Channel to the entrance to the Bendway Channel. This attempt to dam the Bendway Channel failed; the river kept washing it out.

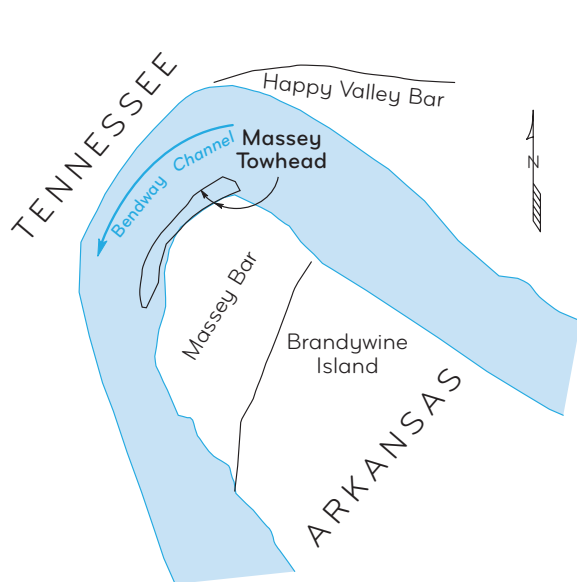
A 1937 sketch shows the conditions where the main flow was through the Bendway Channel but the Pointway Channel was increasing slowly (figure 8-64).

A flood in 1938 provided enough energy to erode Pointway Channel so that it was usable for navigation (figure 8-65). Some traffic still used the Bendway Channel until 1940.

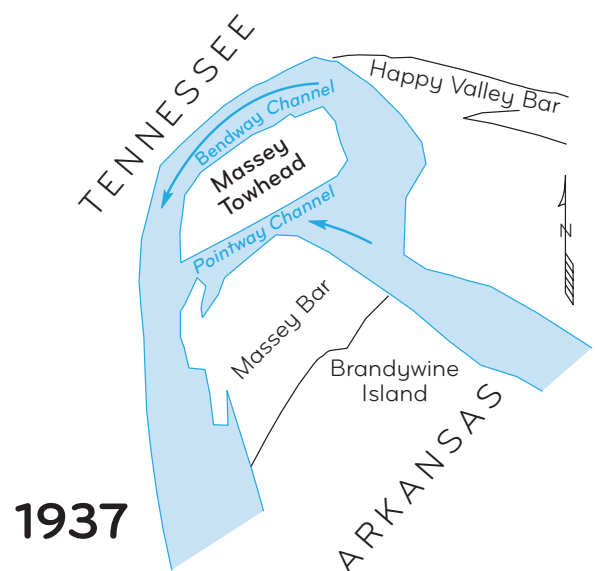
Massey Towhead was now separated from Brandywine Island and Massey Bar by the main navigational channel of the Mississippi.

The Court was asked to find that these gradual changes were avulsive in nature. If the change were avulsive the boundary would be fixed at Bendway Channel.

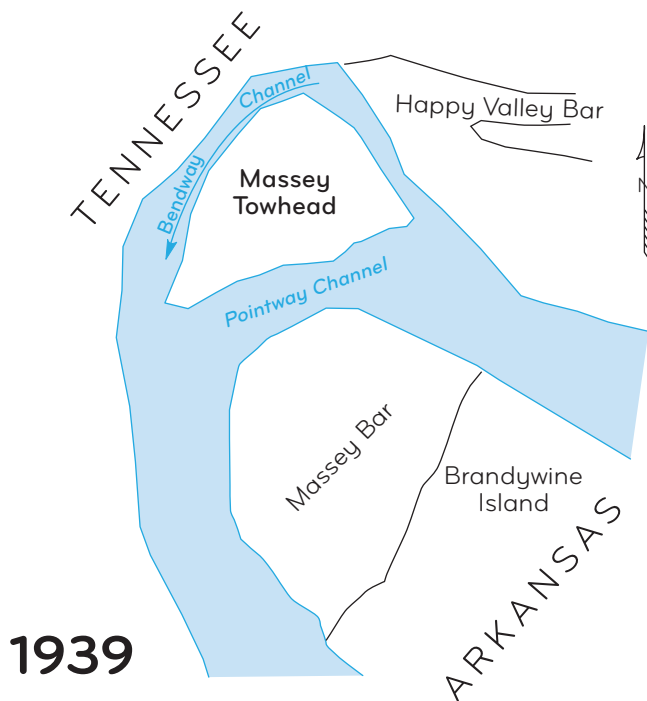
A Special Master appointed by the District Court below found that the elevation of Massey Towhead was 4 feet



**Figure 8-63.** Massey Towhead in 1935, before the Pointway Channel was dredged.



**Figure 8-64.** Progressive changes from 1935 took place as shown on a 1937 map.



**Figure 8-65.** Progressive changes from 1937 took place as shown on a 1939 map.

below the water surface when the river was at ordinary high water.

Note that Tennessee is a “low water mark” State but Arkansas claims to the high water mark.

Mrs. Uhlhorn disputed that finding saying that her deed for Massey towhead called for 705 acres above the OHWM.

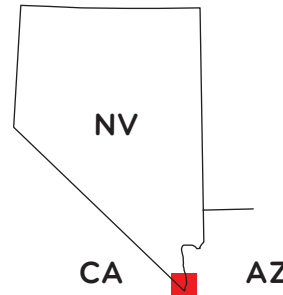
The Special Master’s finding was that the channel change, from the Bendway to the Pointway, was not a true avulsion because the identifiable land was below the OHWM.

The Appeals Court disagreed with the Master. The Court stated that Massey Towhead was a dense compact mass that resisted dredging by the U.S. Corps of Engineers and that it remained unchanged. It stated “we do not think the elevation of the land mass between an old channel and a new one that is cut by avulsive processes is a decisive criterion for a change in a state boundary.” (p. 219)

The Court held that this in-stream artificial narrowing and change in channels was an avulsion and the boundary remained fixed at the Bendway Channel. This situation should properly be classed as a channelization

avulsion within the bed of the river, one that was approved by the Courts.

***Bonelli Cattle Co. v. Arizona***, 414 U.S. 313 (1973), *reh’g denied*, 434 U.S. 1090 (1978), *partially overruled by Oregon ex rel. State Land Board v. Corvallis Sand and Gravel Co.*, 429 U.S. 363 (1977)



**Figure 8-66.** Vicinity map.

Bonelli bought land that consisted mostly of sandy river bed. When the land was originally patented in 1910, it was on the Arizona bank of the Colorado River, a navigable river in this reach. A few years after Bonelli bought the land, the Bureau of Reclamation began a levee project to correct sediment problems and to permit navigation. The river was changed from a wide sandy bed to a much narrower channel. The channelization left a large area of former river bed exposed that the State of Arizona claimed as State lands although it was identical in location with the Bonelli purchase. If the river had avulsed, the State would get the land; but if the process was accretion, Bonelli would get the land.

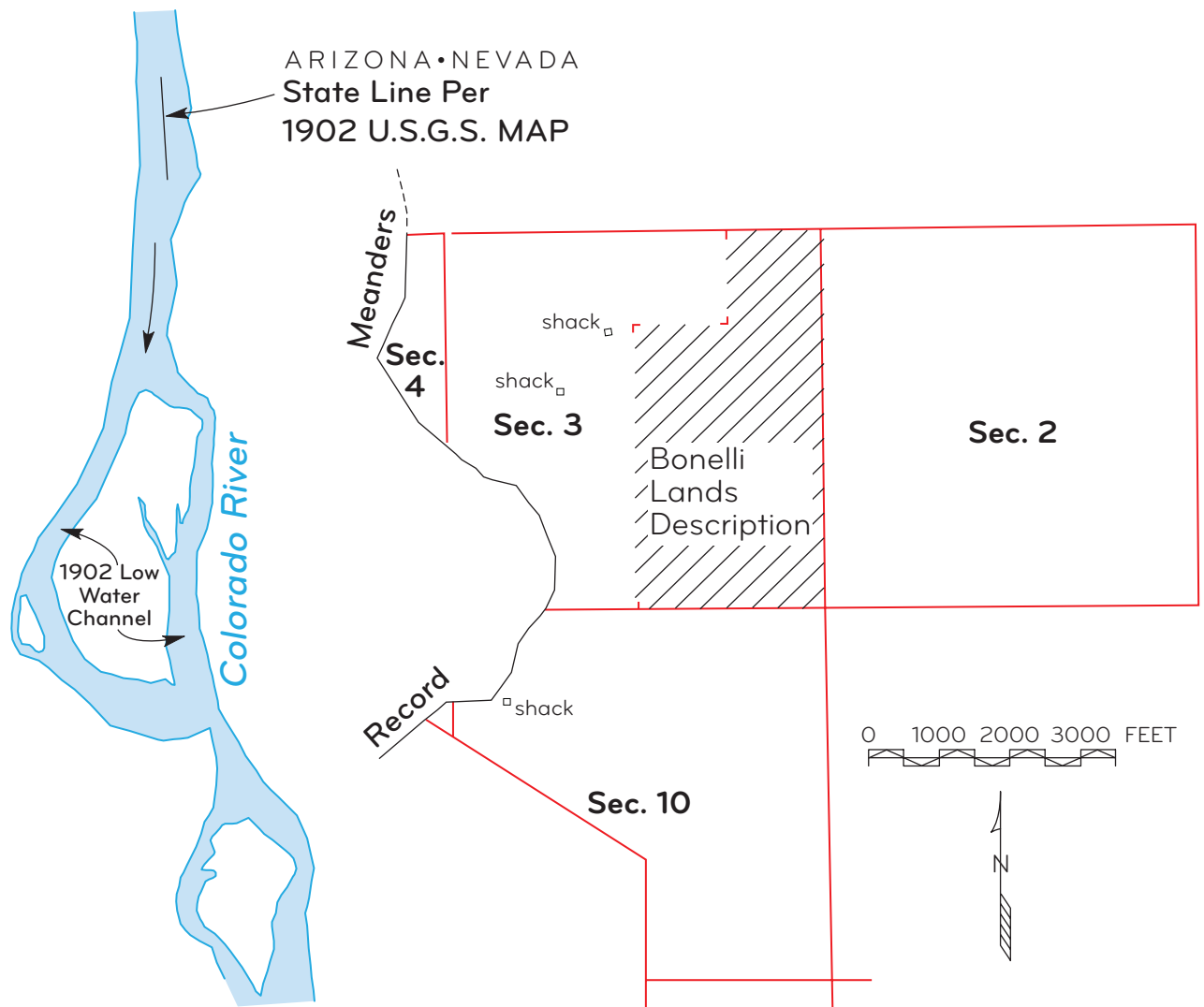
This case is important because here the U.S. Supreme Court defined the boundary effect of channelization where engineering works have narrowed the riverbed, in a suit between a private landowner and a State claiming title as owner of the riverbed.

The GLO surveyed section 3, T. 19 N., R. 22 W., Gila and Salt River Meridian, Arizona in 1905. The section was patented to the Atlantic and Pacific Railroad in 1910.

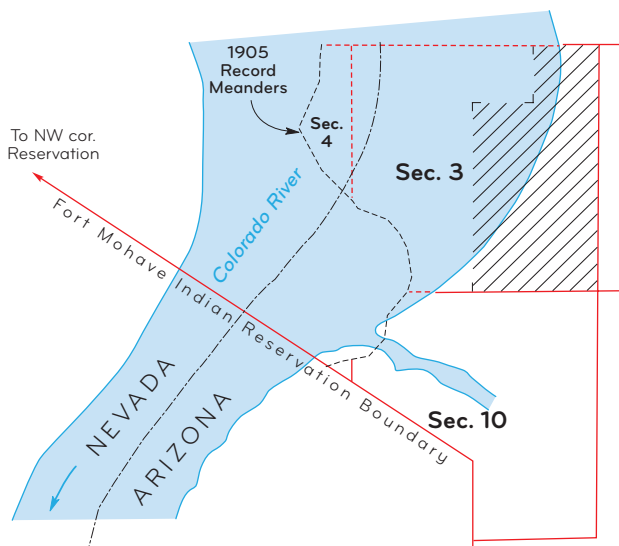
In 1900, 5 years before the GLO Survey, the flowing part of the river was over a half a mile to the west of the disputed lands (figure 8-67). The Colorado River at that time was completely uncontrolled. Large floods would pass through during spring and summer but during some periods the river could be waded. During the low flow times the river bed would be almost totally exposed.

Between 1905 and the 1930s there are few known detailed maps showing this reach of the river. In 1928 a resurvey of the Fort Mojave Indian Reservation shows the river within section 3 although the position of the river was incidental to the survey (figure 8-68).





**Figure 8-67.** The Bonelli lands were over a mile from the Colorado River at the time of the 1905 original survey by the GLO. The river shown here is taken from a 1902 USGS survey map.

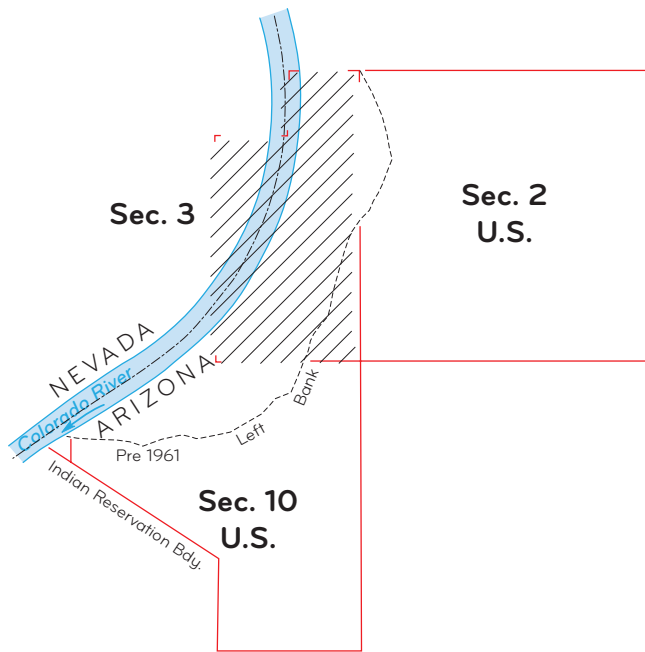


**Figure 8-68.** A 1928 GLO survey of the Fort Mojave Indian Reservation mapped the river at the Bonelli lands as an incident to that work.

Hoover Dam was being built about 75 miles upstream and closed the high flows in about 1935. Because sediment from further upstream was trapped by the dam, the bed below the dam began to erode and moved sediment to the Bonelli area. It was a common problem that normally causes deposition (aggradation) farther downstream.

To permit navigation and to solve the aggradation of sediments, the Bureau of Reclamation began design and construction of training walls (levees) in 1955 (figure 8-69). Dredging then lowered the bed between the levees.

Navigational servitude allowed the Bureau of Reclamation to do this work in the river bed without compensation to the record land owners, the Bonelli Ranch.



**Figure 8-69.** After channelization in 1961, the river was confined to a relatively narrow alignment through the Bonelli lands.

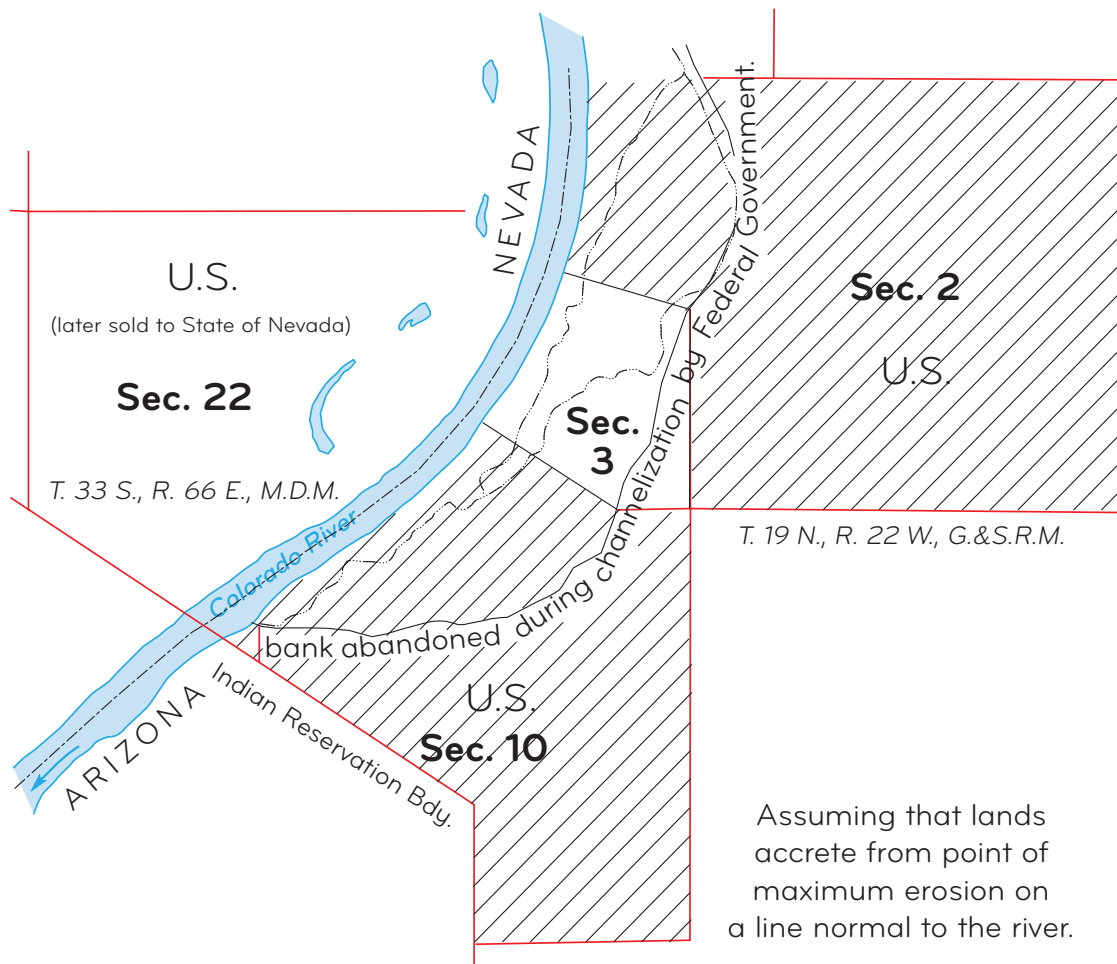
What had been river bed in the disputed area was now dry and protected by the new levees (figure 8-70).

The State of Arizona, as owner of the east half of the river bed, claimed the newly protected area. The State claimed the area had been avulsed.

Bonelli brought suit in the local Court and a trial was held based on an agreed-upon set of facts as to how the river moved. The local Judge ruled that the land belonged to Bonelli as accretions. The State appealed.

A panel of Appellate Judges ruled (11 Ariz. App. 412 (1970)) that under Arizona law if there was doubt as to accretion or avulsion, the presumption was that accretion occurred and affirmed Bonelli's rights. The panel also accepted the Bonelli theory that the land had reemerged due to reliction.

Because the change had the aspect of being sudden and changing the course of the river the State appealed to the full Arizona Supreme Court.



**Figure 8-70.** The remaining Federal lands adjacent to the Bonelli lands. If under Federal law a channelization was equivalent to accretion, the Federal lands would extend to the present river as shown. If equivalent to avulsion, the Federal lands would extend to the former ordinary high water mark under the same theory as the State's.

The Arizona Supreme Court, at 107 Ariz. 465 (1971), proceeded to define the OHWM as having the same meaning as the ordinary high water line and to affirm that Arizona employs the vegetation and the agricultural uses test for determination of the OHWM. They also affirmed, at 108 Ariz. 258 (1972), that Arizona law follows California law in that any human-made change to a river fixes the boundaries of the State-owned beds. The opinion did not even address the avulsion issue but it stated that Arizona law equates channelization to an avulsion.

The State Lands Department still did not agree so it appealed to the Supreme Court of the United States.

Mixed with all the legal arguments the U.S. Supreme Court held that Federal law controlled this decision (later overruled by the *Corvallis* decision discussed below) and because of the limited interest of the State in the former riverbed, held the doctrine of accretion applicable to this suit between the State and a private riparian owner who is seeking title to surface land identifiable as part of his original parcel.

It also held that when the area was dried up there was no need for reserving the bed for navigation so the State should not get the disputed land that was just a windfall. Therefore, it said, the doctrine of avulsion should not apply to this situation because the channelization project was not undertaken to give the State title to the subject lands for the protection of navigation or related public goals. We can only read the outcome as the result of the confusion we described at the outset of this chapter over the purpose for which navigability is determined. The Court appears to have confused, or at least to have used, navigability for purposes of protecting navigation in a case involving navigability for title purposes.

The lower Courts were instructed to issue an order returning the land to the record owners—Bonelli had sold in the meantime.

As it stands, because of the later overruling in *Corvallis* as to the application of State law, a channelization is treated as an avulsive change under Arizona law. What the law is in other States is best left up to the solicitors and attorneys, but there are these conflicting precedents.

The Court did not determine whether Federal law is to be applied in a suit between private landowners (or where the State claims title in some capacity other than

as owner of the riverbed), the differing interests of the parties might require a holding that channelization should be treated as an avulsion.

As a Federal matter, however in a case with the same facts, *Bonelli* may still be the law because the *Corvallis* decision did not completely reverse *Bonelli*. In a riverbed channelized in front of Federal lands of the United States, the doctrine of accretion as utilized in *Bonelli* may be the rule.

*Peterson v. Morton*, 465 F.Supp. 986 (D.Nev. 1979), remanded by, vacated by, in part on other grounds *Peterson v. Watt*, 666 F.2d 361 (9<sup>th</sup> Cir. Nev. 1982)

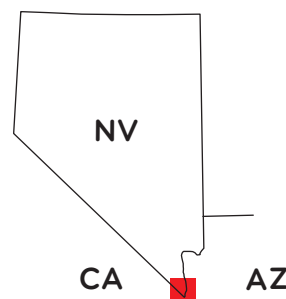


Figure 8-71. Vicinity map.

Blanche Peterson held a deed, which was based on a 1910 patent to the Santa Fe Railroad, to land on the Arizona side of the Colorado River. Movements of the river, erosion on the Arizona side and accretion on the Nevada side, eventually created land at the same geographic location as her Arizona deed but

on the Nevada side of the river (figure 8-72). Peterson claimed that the river moved by a series of small but frequent avulsions rather than by erosion and accretion. She also claimed that these small avulsions fixed the boundaries at each event such that the now emerged Nevada land was still her land in Arizona.

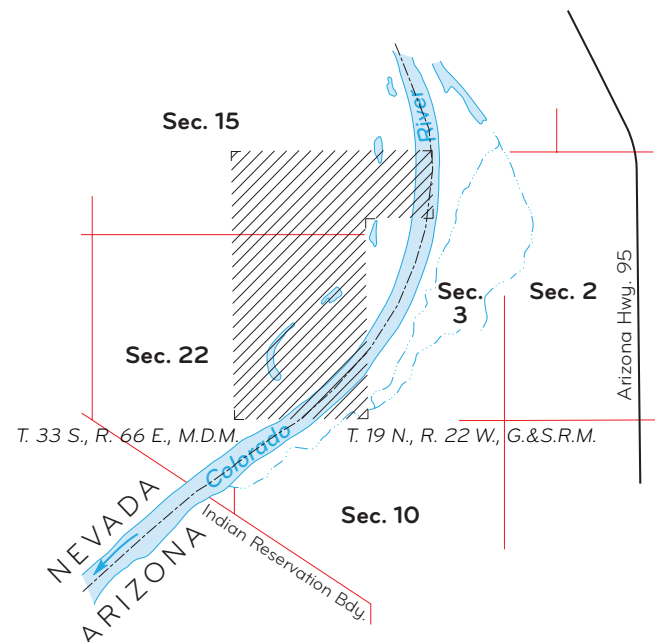


Figure 8-72. Peterson owned the part of section 3 that remained from the Bonelli purchase.

This case is important because it is a relatively modern Federal case that rejected the claim that channel changes within the bed of a river were avulsions. Instead, the Court found that the river moved by the process of erosion and accretion.

The site of this controversy is nearly identical with the disputed lands in *Bonelli v. United States*, 414 U.S. 313 (1973). In fact, the Petersons owned the balance of section 3 not owned by Bonelli.

The Trial Judge described these small avulsions as follows:

This Court is persuaded, by a preponderance of the evidence, and finds that there were no avulsions of any significance between the chalk cliffs and Mojave Point between [dates] . . . This Court excludes as not significant any and all avulsive movements of the river that may have occurred within the river's modern ordinary high water marks, that is, within the bed of the river itself. (p. 995.)

Accordingly, the Court ruled that the accretions had accrued to the riparian uplands owned by the United States and were now Federal lands within Nevada.

The chalk cliffs and Mojave Point were points up and down the river that defined the reach in question.

This decision was appealed on grounds other than the ruling on avulsion but, when modified, did not affect the holding on avulsion within the bed of a river (666 F.2d 361 (1982)).

### Gradual Changes and Boundaries (Case Studies)

**8-108(n) through 8-157(n).** The following case studies illustrate some of the various legal settings in which gradual changes in water boundaries is an issue. Surveyors need to be aware of these situations, which may affect their resurvey work.

#### *Wallace v. Driver*, 61 Ark. 429 (1896)

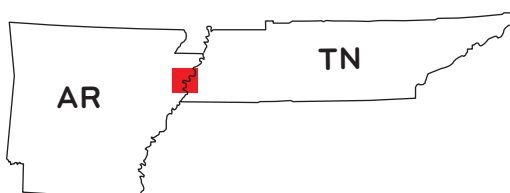


Figure 8-73. Vicinity map.

Driver owned upland along the Mississippi River in the State of Arkansas. Some of his upland had been eroded by the river but, after a 25-year interval, an island began to form in the location where his former holdings had been (figure 8-74). Wallace moved onto the island and Driver brought suit. A jury found that Wallace was unlawfully in possession; Wallace appealed.

This case is presented first so as to affirm that accretions must form against the claimant's upland shores.

Driver owned the "N.W. fractional quarter section 30, in township 13 N., range 11 E., Mississippi County, State of Arkansas." Originally there were 154 acres.

After a large part of Driver's land "caved into the river" a chute formed along what remained of his upland and an island appeared on what would have been within his land description. At low water the chute was dry except for a few potholes but at high water the river ran through the chute.

The Appeals Court held that because the accretions did not form against the uplands held by Driver, that he did not own them. "All original lines submerged by the river have ceased to exist;" (p. 433).

Driver did not prove his claim of ownership so he lost. The Court did not examine Wallace's right to occupy the island, nor the effect of the State line on the Court's jurisdiction.

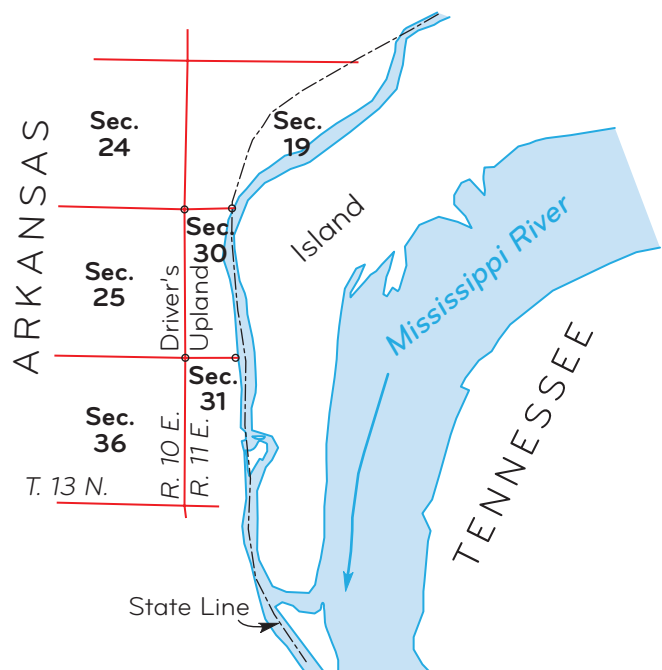


Figure 8-74. The Mississippi River from 1972 USGS maps at the location in question.

**Beaver v. United States**, 350 F.2d 4 (9<sup>th</sup> Cir. 1965), cert. denied, 383 U.S. 937 (1966)

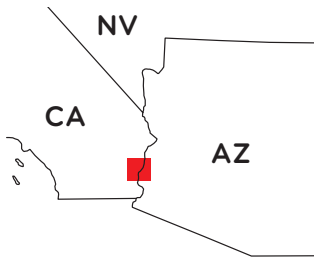


Figure 8-75. Vicinity map.

R. A. Beaver and others claimed to own 11.8 acres along the Colorado River needed by the Bureau of Reclamation for levee construction. Their claim was based on a 1914 patent for the land issued on the Arizona side of the river. The geographic location of the record description (in Arizona) was on the California side of the river because of river movements.

This case holds that accretion can be claimed only on the side of the river where the patented upland is located. It also holds that human-made changes that cause accretion to form do not void the claim for accretions.

One earlier trial had determined that the disputed land was created by accretion on the California side of the river and the proper jurisdiction for trial was in California. The trial was held in U.S. District Court in California.

A second earlier trial rejected Beaver's theory that the land reemerged by the process of reemergence. The doctrine of reemergence is the reappearance of the same soil due to a withdrawal (reliction) of water or elevation of terrain. It is not the process of formation of a new

feature in the same location of a previous feature; that process is accretion, to either the uplands or to the bed of the water body.

The trial court rejected Beaver's theory that the Government induced the accretions and therefore could not claim them. Alternately Beaver claimed that there had been an avulsion. The trial courts also had found that the Government had at all times possessed full title to the tract and Beaver appealed.

There were several other allegations, that the Government should be estopped in this suit because of actions by Government employees and a color of title claim. *Estopped* is a condition where one is stopped or barred by law from alleging or denying a fact because of previous action, inaction, allegation or denial. It had nothing to do with the boundary problem.

The Appellate Court reviewed the trial exhibits and found that the Government had presented more than adequate evidence of land formation by accretion by means of a series of historical maps (figures 8-76 through 8-79). It held that: "The erecting of artificial structures does not alter the application of the accretion doctrine (citing *County of St. Clair v. Lovington*), unless, perhaps, structures are erected for the specific purpose of causing the accretion." (p. 11.)

The Court said that the Beavers equated the "land lost by erosion from the land on the Arizona side" with the "land gained by accretion on the California side" and:

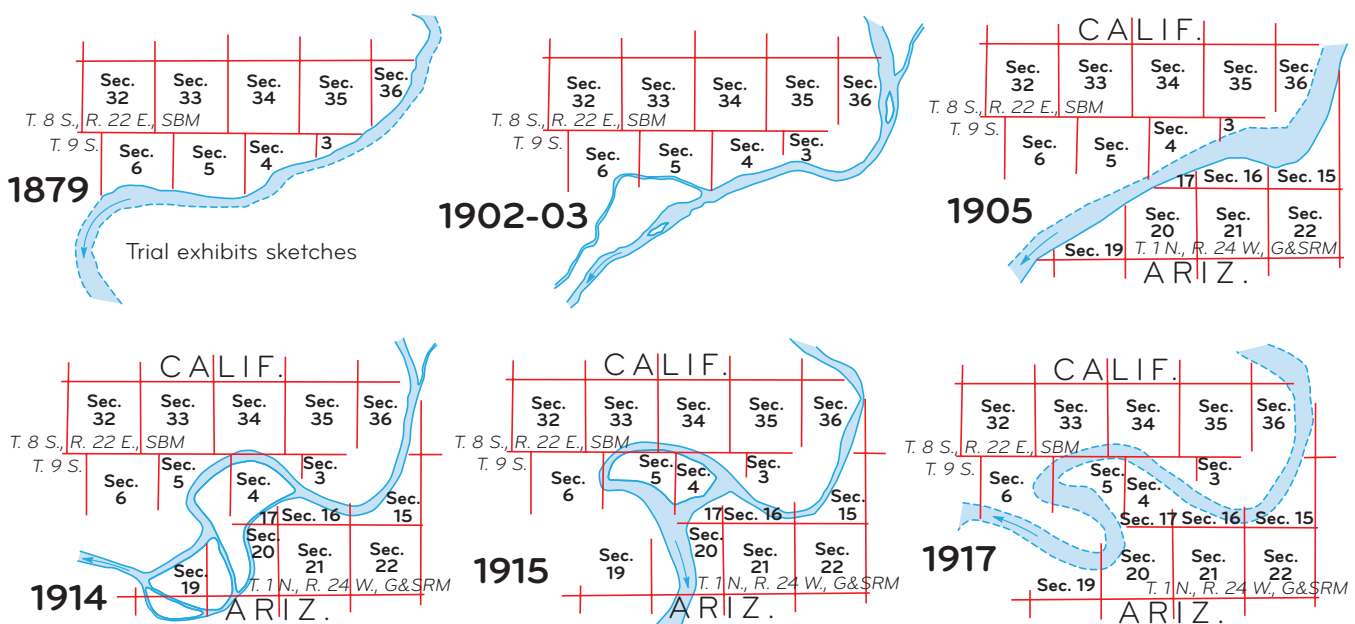


Figure 8-76. Colorado River positions at the Beaver claim from 1879 to 1917.



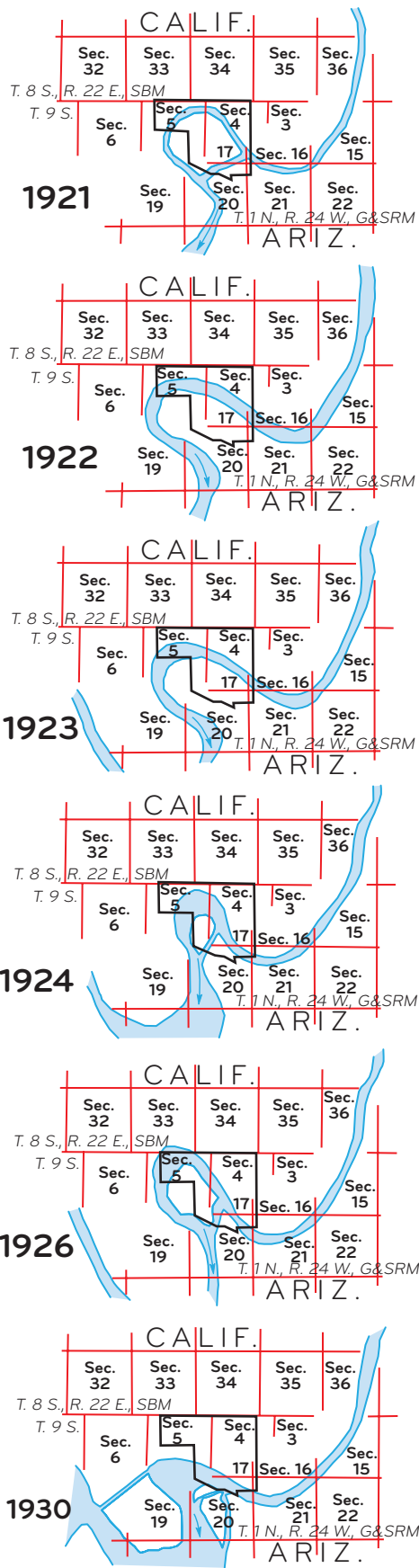


Figure 8-77. Colorado River positions at the Beaver claim from 1921 to 1930.

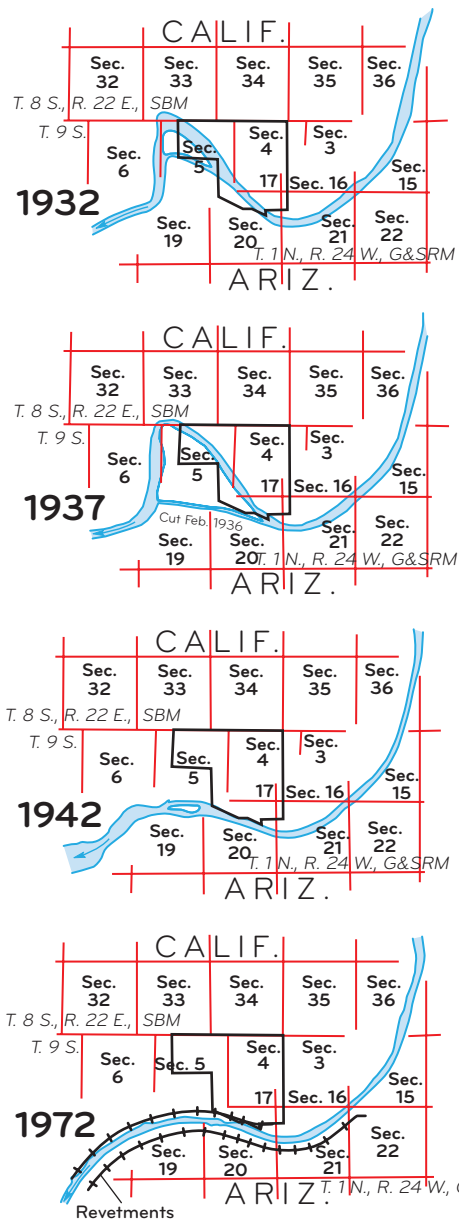


Figure 8-78. Colorado River positions at the Beaver claim from 1932 to 1972.

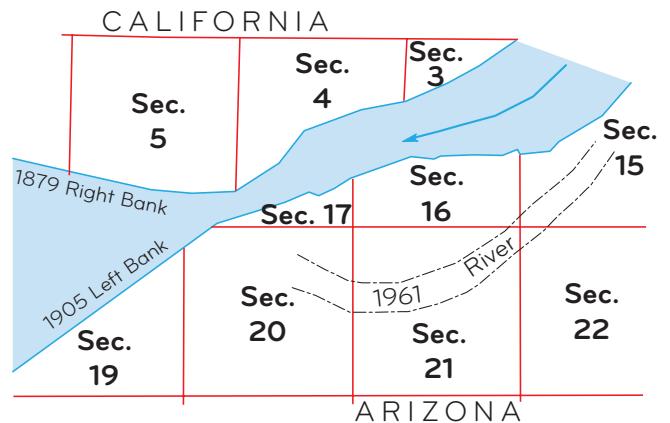


Figure 8-79. Composite of 1879, 1905, and 1961 river positions.

There is no ‘physical identity’ between the two areas of land, even though each is described as within the same section . . . . Accreted land comes from anywhere in the river above the accretion, grain by grain, and so gradually that tracing its source is theoretically impossible. If directly traceable, it more usually is evident that what occurred was the result of an avulsion process. (p. 11.)

The Beaver case affirms that, in Federal decisions at least, accretions must be claimed on the same side of the river as the upland holdings in the absence of any avulsion.

**County of St. Clair v. Lovington, 90 U.S. 46 (1874)**



Figure 8-80. Vicinity map.

East St. Louis, a city in Illinois, is on the eastern (left) bank of the Mississippi. It has been an important rail center since the 1850s because of the shipping down the river as well as the gateway from the east to the larger city of St. Louis, Missouri, just across the river.

The land in question was formerly river bed that was dried up by a dike extending from the Illinois bank upstream to connect to Bloody Island. The island was so named because it was chosen by a number of hot-heads who fought their duels on the island. The site was chosen for dueling because it was considered unclear

whether Bloody Island was in the State of Missouri or Illinois and that fact would hinder any prosecution.

This is an important case for several reasons. It is usually cited by attorneys for its statement of a test for the accretion process as being slow and imperceptible. It also contains language of importance to surveyors that establishes the riparian nature of a boundary from words in the description of the boundary.

Changes in the Mississippi channel affecting steamboat landings in St. Louis began to occur in the 1790s. Bloody Island was just a sand bar then and the main channel was next to the St. Louis bank and was 75 feet deep.

By 1820 the changes were drastic. First it was snags—the harbor area was full of them. Snagboats drew more water than regular steamboats so they couldn’t operate at low water. At high water they couldn’t find the snags. Only a few weeks a year—during medium flows—could the boats operate successfully.

Worse than the snags were the changes in the channels. In 1815 Duncan’s Island was a small bar near the mouth of Mill Creek. In 1820 it dominated the harbor area. By 1837 it was a 200 acre island with cottonwood trees and completely blocked part of the harbor area (figure 8-81).

The basic cause of these events was that the Mississippi was in the process of changing its main channel to run on the east side of Bloody Island. Such a change would make the villages such as Cahokia and Carondelet in Illinois the main shipping port rather than St. Louis.

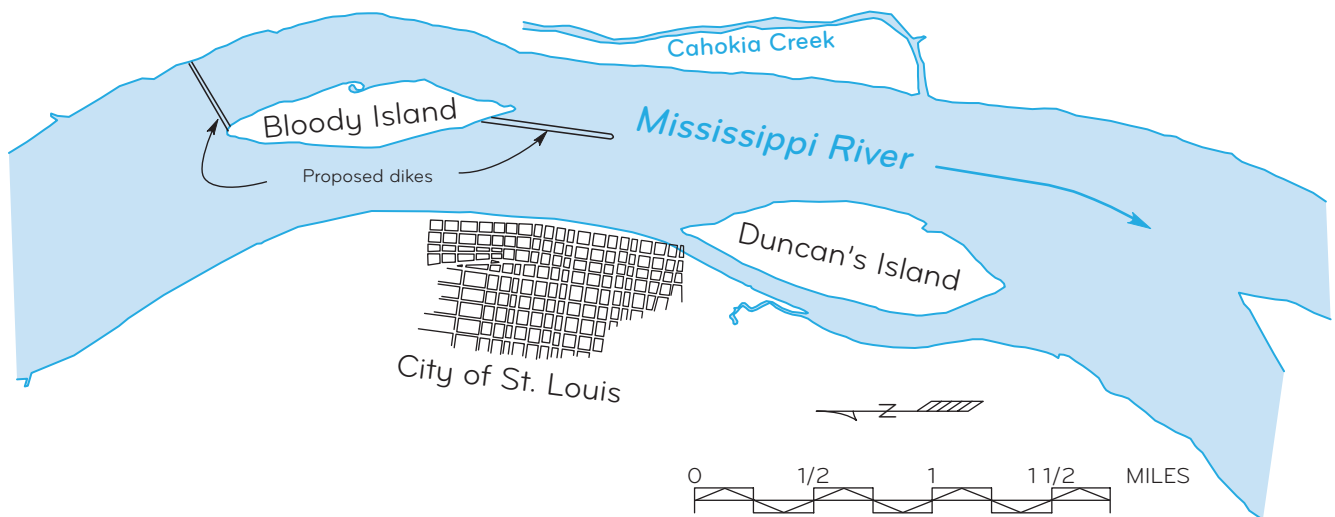


Figure 8-81. St. Louis in 1837 from a map by the U.S. Army Corps of Engineers.

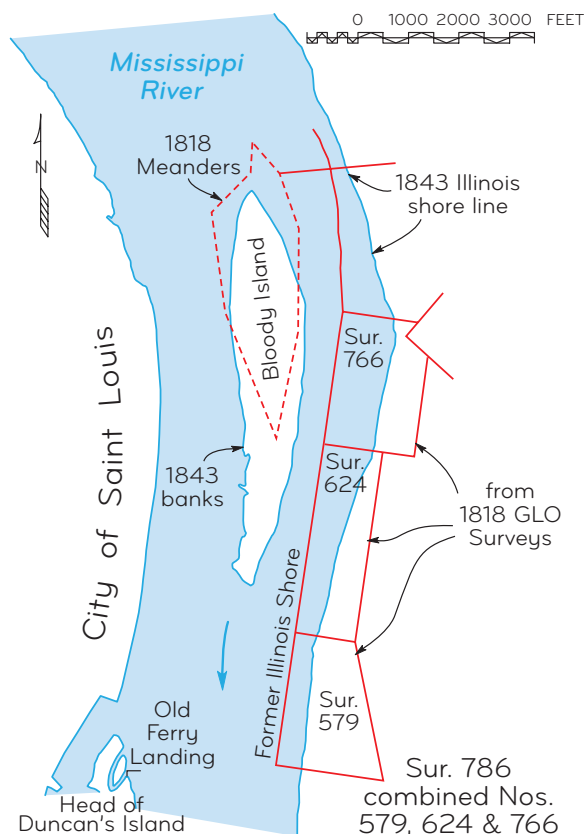
A dike was the obvious answer. It would force more water through the Missouri channel, scouring away both the snags and Duncan's Island. Congress stepped in, sending a team from the Army Corps of Engineers to examine the problem.

The desired dike was designed and constructed by the Corps. Their map of the area showed the triangulation scheme as well as cross sections of the channel in 1837. The Corps was prevented from completion of construction by Illinois efforts to stop the work. The Illinois Legislature later approved the construction.

Lovington was leasing land in Illinois claimed by the Wiggins Ferry Co. Wiggins Ferry ownership was based on United States Surveys 579 and 786 (figure 8-82).

The County of St. Clair, Illinois, was given a grant from the United States by Act of Congress of July 15, 1870, which read in part:

That the title of the United States to all lots, outlots, tracts, pieces, parcels, and strips of land in St. Clair County, State of Illinois, lying and situate outside of the United States surveys as noted in



**Figure 8-82.** The GLO surveyed lots along the channel between Bloody Island and the Illinois bank as well as Bloody Island itself.

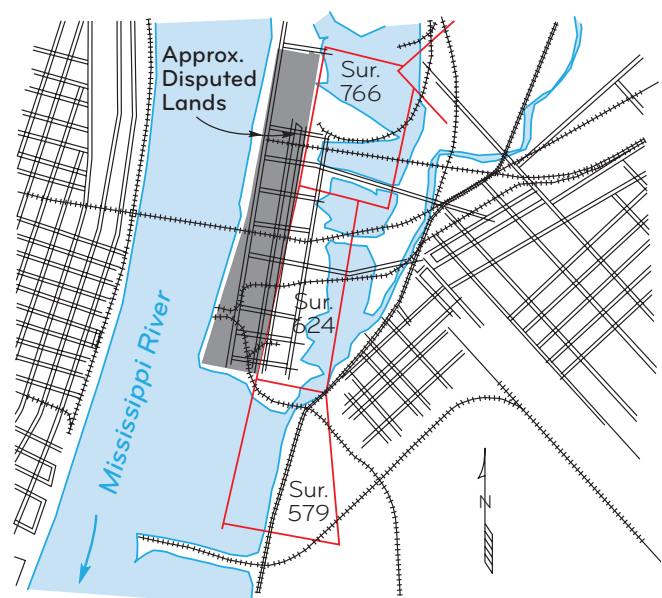
the field-notes of the United States surveyors, and on the Mississippi River near Surveys 766, 624, and 579; and near and adjacent to fractional sections 1, 2, 11, and 12, township one north, range ten west, third principal meridian, be, and the same is hereby, confirmed and granted to said St. Clair County in said State: Provided, That nothing herein shall apply to the ancient French Commons in Said County.

The County claimed land that had accreted (or relicted because of the dike construction) in front of the uplands owned by Wiggins (figure 8-83). Its basis for claim was that the Wiggins' land was *Ager Limitus* that is, bounded by a fixed description of boundaries from point to point. According to the County's claim, only land bounded by the river could benefit from accretions, which would preclude Wiggins from doing so.

Lovington and Wiggins claimed the accreted land by riparian right.

The Court accepted the case with two questions to be determined:

- (1) Whether the river line was the original west boundary of the surveys, or of either of them? A mixed question of fact and law.
- (2) If No. 1, above, is in the affirmative, to whom do the accretions belong? It was a question of fact.



**Figure 8-83.** From an 1878 map of East Louis, with disputed lands accented by a heavy shading.

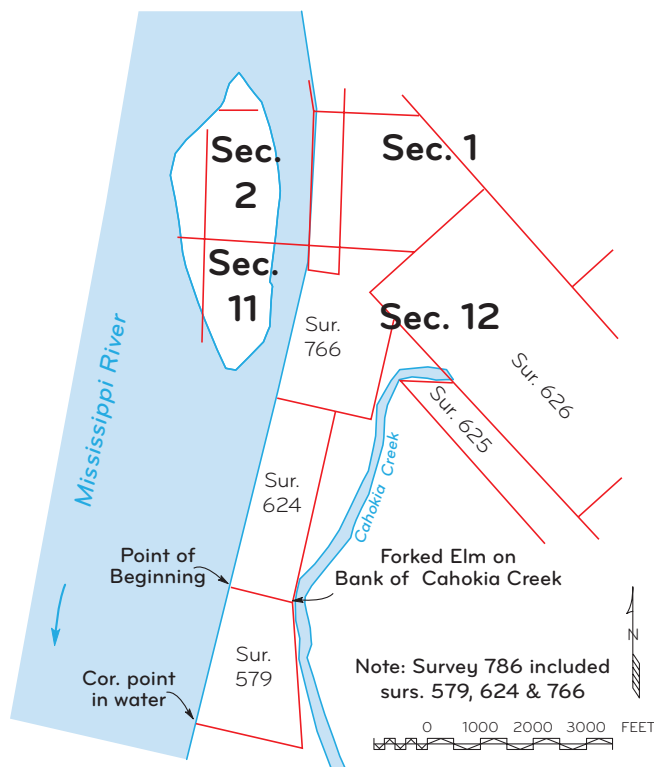
Court records show that U.S. Survey 579 was described in part as:

Beginning on the bank of the Mississippi River, opposite to St. Louis, from which . . . [bearing tie] . . . ; thence S. 5 West 160 Poles to a point in the river from which a sycamore 20 inches in diameter bears S. 85 E. 250 links, thence S. 85 E. 130 poles (at 30 poles a slash) to a point; thence N. 15 W. 170 poles to a forked elm on the bank of Cahokia Creek; thence N. 85 W. 70 poles to the beginning.

The calls of U.S. Survey No. 786 are, in part, “Thence N. 85 degrees W. 174 poles, to a post on the bank of the Mississippi River, from which [tie omitted]; thence N. 5 degrees E. up the Mississippi River and binding therewith . . . .”

These two descriptions are plotted in figure 8-84.

The U.S. Supreme Court said that, as to Survey No. 579, there could be no reason for having the two corners on the river and having the line between them deflect from the river. The Opinion stated that there was no doubt but that the line intended was to be along the river.



**Figure 8-84.** Corner monument descriptions in the field notes became the most important evidence of intent.

As to Survey No. 786 the U.S. Supreme Court said, “The language ‘up the Mississippi River and binding thereon’ leaves no room for doubt. Discussion is unnecessary. It could not make the result clearer. The river must be held to have been the west boundary of this survey also.” (p. 66.)

The Court had previously cited some of the axioms of the land surveying profession:

It is a universal rule that course and distance yield to natural and ascertained objects.” (*Preston’s Heirs v. Bowmar*, 19 U.S. 580 (1821).) “A call for a natural object, as a river, a spring or even a marked line, will control both course and distance. (*Newsom v. Pryor’s Lessee*, 20 U.S. 7 (1822) (p. 62).)

Artificial and natural objects called for, have the same effect. (*Barclay v. Howell’s Lessee*, 31 U.S. 498 (1832); *Baxter v. Evett’s Lessee*, 7 Monroe 333 (p. 62).)

Also:

Where a survey and patent show a river to be one of the boundaries of the tract, it is a legal deduction that there is no vacant land left for appropriation between the river and the river boundary of such tract. (*Churchill v. Grundy*, 5 Dana 100 (p. 63).)

Where a deed calls for a corner standing on the bank of a creek, ‘thence down said creek with the meanders thereof,’ the boundary is the water edge at low water mark. (*Lessee of McCulloch v. Aten*, 2 Ohio 307 (1826); *Handly’s Lessee v. Anthony*, 18 U.S. 374 (1820) (p. 63).)

(Other axioms and their citations were given other than are repeated here and served to settle question No. 1. The river was the boundary.)

As to the owner of the accretions in question No. 2, the Court held that the surveys were not in the “category of the *agri limitati* of the civil law” by which “[t]he increase by alluvion in such cases did not belong to the owner of the adjoining plat” (*Wiggins*, p. 66).

The Court’s definition of the test as to whether land formed slowly or not is much quoted: “The test as to what is gradual and imperceptible in the sense of the rule is, that though the witnesses may see from time to

time that progress has been made, they could not perceive it while the process was going on.” (p. 68.)

Finally the Court stated that the United States never had any title to the strips of land along the U.S. Surveys and that nothing passed to the County by the Act of Congress relied upon by the County. The disputed accretions thus belonged to the upland owners Wiggins and Lovington.

### Islands (Case Studies)

**8-158(n) through 8-164(n).** The following case studies illustrate some of the various legal settings in which islands are an issue. Surveyors need to be aware of these situations, which may well affect their resurvey work.

***Scott v. Lattig*, 227 U.S. 229 (1913), rev'g, 17 Idaho 506 (1910)**

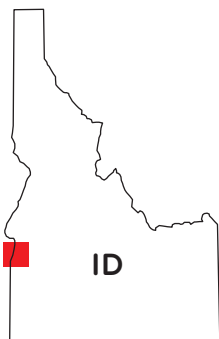


Figure 8-85. Vicinity map.

Title to a large island was at issue. The Idaho State Supreme Court had found that Poole Island in the Snake River between Idaho and Oregon had been “left out of” the 1868 survey by the GLO. In the field notes there was no mention of an island adjacent to sections 15 and 22 nor did the plat show an island (figure 8-86).

We study this case because it is a leading case for unsurveyed islands and because the State law in Idaho was that upland owners held title to the center of navigable streams.

Samuel Poole made an application and purchased lots 2, 3 and 4 of section 15 by patent in 1894. About half of the island lay alongside the lots Poole owned. Poole had been living on the island since 1883 and continued to live there until the time of the trial in 1912.

Robert Green had occupied the southern portion of the island so he applied for and received a Homestead Patent for lots 1 and 2 of section 22 in 1895. One S. L. Sparks similarly owned the southern part of section 22.

John Scott, an employee of Poole, lived on the island a few years and then applied to the GLO to have the island surveyed as part of the public domain. (The request for the survey was one of the steps required in order to purchase an unsurveyed island from the Government.)

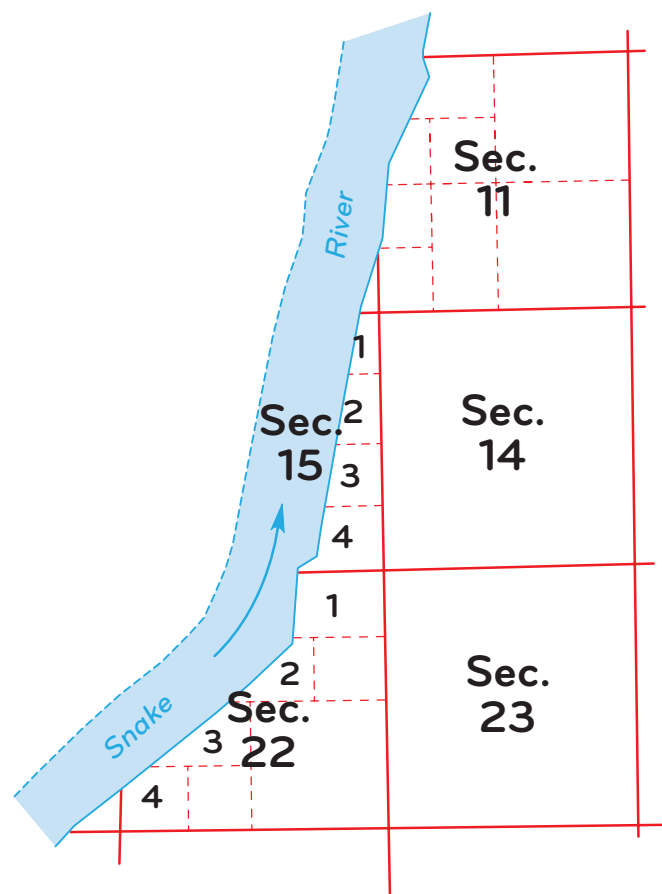


Figure 8-86. A sketch from an 1868 GLO plat of T. 9 N., R. 5 W., Boise Meridian, Idaho.

The island survey was subsequently ordered and was completed in 1906 (figure 8-87). Scott was later issued a patent to the island.

In the meantime Poole had sold his patented land to Lattig. Lattig, Green and Sparks sued Scott. The State trial court found that Lattig and his neighbors had owned the land along the bank for 20 years, had paid taxes on it, managed the island and controlled it. The Court also found that the main channel of the river was westward of the island and that Lattig and others were the owners of the island as part of their mainland holdings.

Scott appealed to the Idaho Supreme Court. The Idaho Court started out by saying that the grants of land were to be construed according to the laws of the State where the land was located. Accordingly, the Government’s grant to Scott would be construed by Idaho law.

Idaho law was that upland owners owned the beds of rivers to the center whether the river was navigable or not. The Court also said that the channel between the Idaho mainland and Poole Island was a high water channel or slough that was nonnavigable.



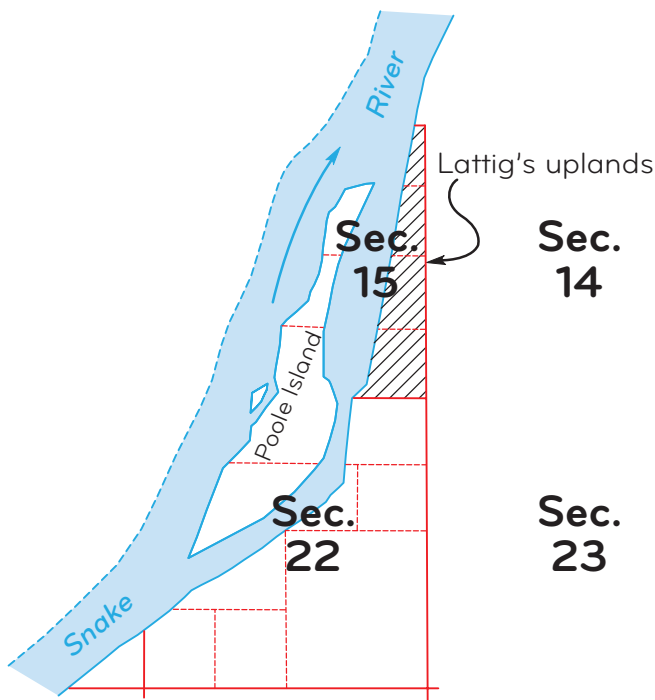


Figure 8-87. A sketch from a 1906 GLO plat of Poole Island.

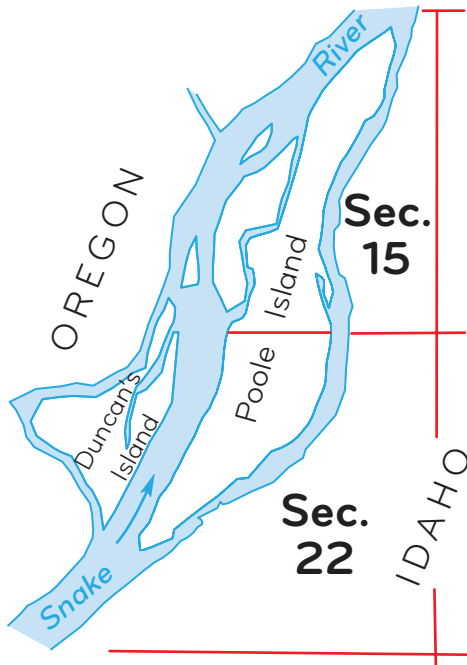


Figure 8-88. Poole Island from 1974 USGS mapping.

Quoting *Railroad Company v. Schurmeir*, 74 U.S. 272 (1869) and a number of U.S. Supreme Court Decisions, the Idaho Court affirmed the lower court's judgment that the upland owner's title went to the center of the Snake River and that the patent to Scott was not valid. There was, they said, no evidence that the island even existed at the time of the original survey, and it could have been a mere sandbar that later formed into an island.

Scott appealed to the Supreme Court of the United States. The U.S. Court held that the island was in existence at the time of the original survey and that it remained public land of the United States at the time of patents to Poole, Green and Sparks (figure 8-88).

The patent to Scott based on the 1906 island survey was thus found valid.

*United States v. Hutchings*, 252 F. 841 (D. Okla. 1918), *aff'd*, *Commissioners of Land Office of State of Oklahoma v. United States*, 270 F. 110 (8<sup>th</sup> Cir. 1920), *appeal dismissed*, 260 U.S. 753 (1922)



Figure 8-89. Vicinity map.

Title to the same island described in *Commissioners* on the Arkansas River in Oklahoma was at stake. The original surveys in 1871 and 1872 showed the island but the GLO did not survey it as part of the Indian Reservation until 1908 (figure 8-90).

The other defendants set up a defense that there really wasn't any island at all because the original surveyors did not survey it for patent. Because they owned upland patents on the south bank they claimed the disputed

This case illustrates how facts may affect application of legal theories.

The United States claimed the island on behalf of the Osage Tribe of Indians and one Larry Nolegs. The State of Oklahoma claimed the island as a part of the bed of a navigable stream. Oil and gas leases were issued by the State to other defendants in this litigation.

The other defendants set up a defense that there really wasn't any island at all because the original surveyors did not survey it for patent. Because they owned upland patents on the south bank they claimed the disputed

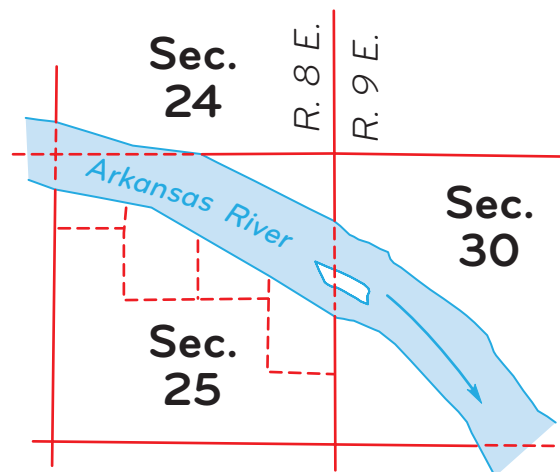


Figure 8-90. The disputed island from the original survey plats.

area as accretions that passed with their titles. The other defendants also claimed that the reservation boundary was fixed by specified descriptions and acreage, that the description of the reservation boundary at the “main channel of the river” presented a question of fact as to which of two channels was the main channel and, further, that the allotment to Larry Nolegs was illegal.

The Government claimed the river was not navigable and that the Osage Tribe owned to the center of the river that at the time of the grant from the Government was located on the south side of the island.

Held: The Court ruled that the river was not navigable at the location of the island—that threw out the State’s claim, which was based entirely on navigability.

The Court said:

The assertion that the island had no existence at the date of original survey, commenced in 1871 and finished in 1872, is wholly untenable, as it was indicated in the river by the plat and field notes, and its substantial formation is clearly established by the evidence. The island was not meandered or surveyed into lots, but the omission is unimportant, as the engineers generally did not survey islands in the Arkansas River; and the title would not be affected if the island had been entirely ignored. *Scott v. Lattig*, 227 U.S. 229 (1913) and *Moss v. Ramey*, 239 U.S. 538 (1916). (p. 843.)

As to the channel question, the District Court said:

It was further contended by the same counsel that the Act of June 5, 1872, in bounding the reservation by the ‘main channel’ meant simply the ‘main branch’ of the river in the sense of the main Arkansas River. But the terms are not equivalent, as a ‘channel’ of a river is less comprehensive and means primarily its bed, while a ‘branch’ of a river may have two or more separate channels. The act clearly indicates a legislative intention to designate the main or principal channel as a boundary at places where this river had more than one channel, as, for example, where it divided about an island. In such case, the main channel and not the entire channel between the extreme shores was fixed, therefore, as the true boundary. Otherwise, the plain language of the act would not be given effect. (p. 844.)

If the boundary had been described merely as the Arkansas river, the division line between the riparian owners would be the middle of the stream; and, if that line had fallen upon the island, a division of the island would be required accordingly. *Whitaker v. McBride*, 197 U.S. 510 (1905). But such was not the case, and the location of the main channel on June 5, 1872, must be found in order to determine whether the channel was within or without the reservation. (p. 844.)

The District Court held that the southern channel was the main channel and confirmed the title of the Indian tribe (figure 8-91).

An analysis of the above paragraphs may be useful:

(1) The Act, referred to above, was the Act of Congress of June 5, 1872. The language of the Act says, “and the main channel of the Arkansas river for a southern and western boundary.” No clarifying terms appear elsewhere in the language of the act.

(2) The word “channel” can mean different things to different people. To a hydraulic

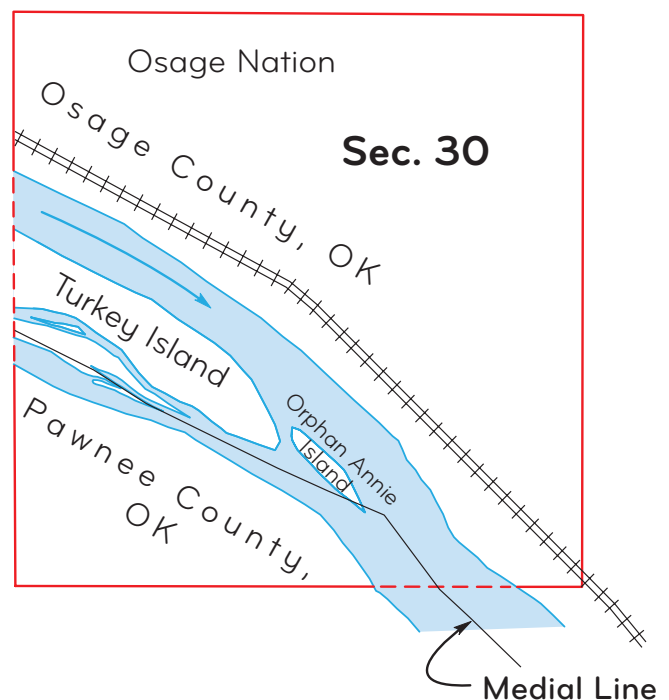


Figure 8-91. A sketch from the 1935 GLO survey to comply with 270 F. 110.

engineer the channel is the waterway cross-sectional area that “can” be physically occupied by the river during a flood event. To a boat pilot it is the part of the flowing water to be used for navigation. To the Judge the channel meant the entire bed of the river on one side of an island or another—presumably at ordinary flows.

(3) The location of the main channel where one or more islands divide a river is a question of fact to be determined by measurements. While a bed on one side of an island may be the widest, the larger flow of water in cubic feet per second may flow through on the opposite side of the island. The Court here found that the southern channel was the widest and contained the “chief” flow at the time of the Act in 1872.

(4) The syllabus in *Whitaker* cited by the Court, reads as follows: “Where the government has surveyed and patented the lands up to the bank of a channel in which an unsurveyed island is situated, a patentee of the land on such bank, although his land may itself be an island surrounded by two channels of the river, has all the rights of a riparian owner in the channel lying opposite his banks, including the unsurveyed island if, as a riparian owner, he is entitled thereto by the laws of the State.”

(5) In *Whitaker*, the Court found, “that the Government, as original proprietor, has the right to survey and sell any lands, including islands in a river or other body of water; that if it omits to survey an island in a stream and refuses, when its attention is called to the matter, to make any survey thereof, no citizen can overrule the action of the Department, assume that the island ought to have been surveyed, and proceed to occupy it for the purposes of homestead or preemption entry. In such a case the rights of riparian proprietors are to be preferred to the claims of the settler (p. 516).

***Wolff v. United States***, 967 F.2d 222 (6<sup>th</sup> Cir. 1992),  
*reh’g denied*, 974 F.2d 702 (1992)  
***Olive Wheeler***, 108 IBLA 296 (1989)

Huckleberry Island, approximately 0.9 acres in size located in Arbutus Lake in northern Michigan, was left unsurveyed by the GLO in 1839 and 1852. BLM surveyed the island in 1985 and filed a plat in 1986, claiming the island was public domain land. The island

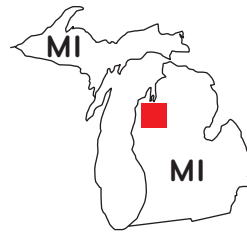


Figure 8-92. Vicinity map.

occupant protested the survey, claiming ownership stemming from a Federal railroad grant of the adjacent uplands that they ultimately purchased. The protest was dismissed by the BLM. Plaintiff appealed that decision to the IBLA, where the BLM’s decision was affirmed, *Wheeler*. The occupant sued in District Court and won in *Wheeler v. United States*, 770 F.Supp. 1205 (W.D. Mich. 1991). The Government appealed.

This case contains an important deviation from previous court decisions on unsurveyed islands. The decision distinguishes between a number of previous decisions and so is useful for evaluating survey methods.

T. 26 N., R. 10 W., Michigan Meridian was first surveyed in 1839 but the survey was found to be defective so GLO resurveyed it in 1852. Neither of the two surveys surveyed or lotted the island in dispute that was left unsurveyed in section 9 (figure 8-93). In each case the

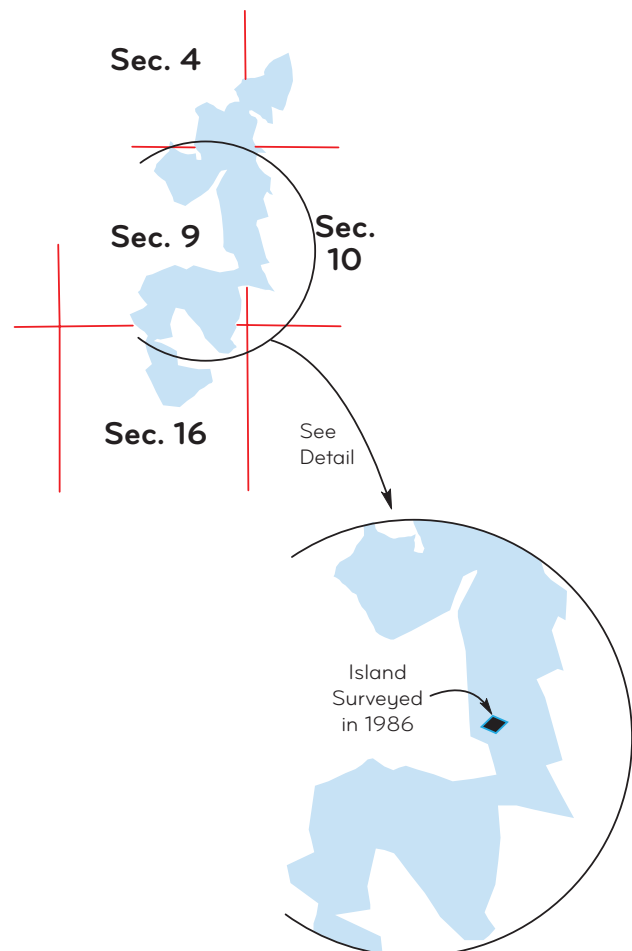


Figure 8-93. Arbutus Lake from an 1888 GLO survey of T. 26 N., R. 10 W., Michigan Meridian.

island was not surveyed consistent with GLO instructions at that time not to survey islands that were unsuitable for cultivation, and according to the trial court's findings.

Section 9 was part of an indemnity selection by the State of Michigan to make up for shortage of a previous grant in aid of railroad construction.

The State conveyed section 9 to the railroad involved and the railroad subsequently sold to the occupant's predecessors in title.

The occupants paid taxes on the island from 1921 and built a cabin.

In 1985 the BLM survey identified the island as Tract 39. As stated previously, the filing of the plat in 1986, in its effect, claimed the island as Government land, which led to the litigation.

No claim of navigability or nonnavigability was made at District Court trial and it is important to know that, under Michigan law, upland owners are considered to own the beds of nonnavigable as well as navigable waters abutting their property.

The District Court Judge made lengthy comparisons with previous cases regarding islands, which are paraphrased here:

*United States v. Mission Rock Co.*, 189 U.S. 391, 404 (1903): The Court noted that that case involved tide waters whereas Huckleberry Island is in nontidal waters.

*Whitaker v. McBride*, 197 U.S. 510 (1905): The Court noted that in *Whitaker* the island was not surveyed according to instructions, in that no islands less than 21 acres were to be surveyed but the island in dispute was 22 acres in size. This Judge considered that the surveyor made a mistake in not surveying the *Whitaker* island.

*Scott v. Lattig*, 227 U.S. 229 (1913): The surveyor in the Scott case was under a duty to survey the large island but failed that duty. By implication, the Judge wrote, where the surveyor is under a duty to not survey an island, the Federal Government grants the State the authority to dispose of the island.

*Hardin v. Jordan*, 140 U.S. 371 (1891): The Court noted that, under *Hardin*, the riparian owner took title to the bed of the lake out to the middle of the lake and owned the bed subject to an easement of navigability.

*Grand Rapids and Indiana Railroad Co. v. Butler*, 159 U.S. 87 (1895): The Court noted that the surveyor did not survey the island because it was not of sufficient value to warrant survey as opposed to not surveying because it was unsuitable for cultivation.

Citing these and other cases, the District Court formulated a series of rules (p. 1208):

Rule: Where the government has not made any reservation in its grant, under the common law, a riparian owner on a navigable river cannot take title to islands in the river by way of his ownership of the riparian tract.

Rule: Where the government has not made any reservations in its grant, under the common law, a riparian owner on a lake, without regard to the lake's navigability, takes title to any unsurveyed islands which fall within the area bounded by lines drawn from the edges of the riparian tract to the center of the lake.

Rule: Where an island was not surveyed because it did not appear to be of sufficient value to survey (and not because of mistake or fraud), without regard to the navigability of the water, the riparian owner cannot be divested of title to the island by way of a later survey.

Rule Title to islands in unsurveyed navigable, tidal waters remains in the United States, although ownership of the bed underlying those unsurveyed waters is determined according to state law.

Rule: Where the government chooses not to survey an island, by operation of common law a riparian owner's title to that island is superior to anybody else's title, except perhaps the government's.

Rule: Where the United States fails to survey an island because the island is of no apparent value, title to the island passes to the riparian landholder.

Rule: Where an island is clearly in existence at the time of survey, and the surveyor had a duty to survey the island but was negligent in that duty, title to the island remains in the United States.



The Sixth Circuit Court of Appeals, 967 F.2d 222, affirmed the District Court Decision in favor of Plaintiff Wolff who replaced Wheeler as plaintiff.

The Appeals Court held that grants for lands bounded on streams and other waters are to be construed as to their effect according to the law of the State in which the lands lie. It held that in *United States v. Chandler-Dunbar*, 209 U.S. 447 (1908) and the *Grand Rapids v. Butler*, cases (both in Michigan) that a grant of the littoral land included an island and that was the Michigan Law.

The Appeals Court also considered the comparative area of the primary grant and area of the island. They held that a purchaser would not be likely to believe that a large island was included in the grant but that a small island would be considered part of the package. This suggested that the United States did not intend to retain the island.

In addition the Appeals Court considered that the long period between the surveys and the fact that the Government did not reserve an access to the lake—they patented the entire shoreline—as suggesting that there was no intent to retain the island.

Heretofore the Government has always considered that Federal law controlled the interpretation of grants of land until the title passed. After title passes it considers State law to control. The Government has also considered, in the past, that title to all unsurveyed islands remains in the Government in nonnavigable streams as well as navigable streams.

Because of these fundamental differences, this case is very significant in determining title to unsurveyed islands in the sixth circuit.

***Koch v. United States***, 824 F.Supp. 996 (D. Colo. 1993), *aff'd*, 47 F.3d 1015 (10<sup>th</sup> Cir. 1995), *cert. denied*, 516 U.S. 915 (1995)  
***Exxon Corp. v. Bureau of Land Management***, 118 IBLA 38 (1991)

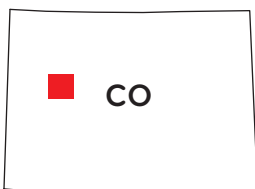


Figure 8-94. Vicinity map.

In 1975 the United States began survey investigations on 22 land masses in the Colorado River near the town of Rifle, Colorado to determine if they were unsurveyed islands.

Nine unsurveyed island surveys were eventually accepted and were announced in

the Federal Register for filing. Filing the surveys constitutes a Federal claim of ownership. Interested landowners protested the proposed findings. The Colorado State Director of the BLM dismissed the protests. That decision was then appealed and, after a hearing before an Administrative Law Judge, was reversed. The Government appealed to the Interior Board of Land Appeals. The IBLA reversed the Hearings Judge and declared the islands had been omitted from the original survey and remained the property of the Federal Government. *Exxon Corp.*

Koch and other upland owners brought suit in Federal Court.

The Colorado River, in this reach, was stipulated by both parties to be a nonnavigable river. The evidence developed that each island had at least one tree that age dated to a time before the original survey (meaning that the island was in existence at the time of survey). Each parcel was found to be above the OHWM of the river at the time of the original survey and at all times since.

This case is considered to be important because the Appeals Court's Decision followed *Wolff*, above, and based their holding on an interpretation of the Government's intent when the patents were issued. Prior to the *Wolff* decision nothing had been held to pass title by implication.

The Appeals Court found that the most important evidence of the Government's intent was that the original surveyor's approved field notes and plats are a part of the description of the lands granted and that they described the islands, respectively, as "a bar or low island," a "long low island, overflowing and unfit for cultivation" and a "low overflowing island . . . bar or island." The Court reasoned that the inclusion of these descriptions of the islands was highly persuasive of the Government's intent to include the islands in the patents of the riparian lands.

Also, the Appeals Court held that the Federal Government's intent to reserve the island was not clear because the Government did not expressly reserve the islands, they were of little value at the time of survey, that the Government did not reserve any access to them across the uplands, and that they had never been treated as public lands by the Government. Accordingly, the Court found the islands were included in the patents, State law is to be applied to decide ownership, and by Colorado law the islands passed to the adjacent owners.



By Colorado law, plaintiffs Koch et al. were found to have title to the islands.

After making it clear this was not a case about title passing under the equal footing doctrine, the Appeals Court stated if the Federal Government intended to retain the islands as public land, then the islands remain the property of the United States. The Federal Government's intention controls the disposition of land granted by Government patent; thus, the Federal Government is not bound by its mistakes.

From an earlier U.S. Supreme Court decision on a navigable river, regarding the Federal Government's intent, and errors and mistakes by the original surveyor, it was held that the fact of islands left unsurveyed by the Federal Government by mistake provides evidence that the Government intended to retain the islands. *Moss v. Ramey*, 239 U.S. 538 (1916).

The parties stipulated that the Government did not originally survey the islands because they were of little value; the geographic positioning of the islands does not clearly show intent; the Government had patented all the area around the islands and had no access to the islands. The Court found no Government intent either to retain or to dispose of the islands. The Court did find that the record did not clearly reveal the Government's intent and the patents were silent.

The Appeals Court also rejected the Government's argument to subject the patents to the general rule of construction that any ambiguity in a grant is to be resolved favorably to a sovereign grantor; that nothing passes but what is conveyed in clear and explicit language. The Court citing the Supreme Court said that interpretive technique is not used when examining the effect of a patent on islands in adjacent nonnavigable waters, when the Government's intention is ambiguous. Instead, it is to be taken the Government assented that the conveyance may be construed according to the law of the State in which the land lies. *Oklahoma v. Texas*, 258 U.S. 574, 595 (1922).

The source of law question and analysis is different where the Government has never parted with title and its interest in the property continues, such as an Indian reservation. In those cases the title to the unsurveyed islands shall be decided by Federal law.

The Government still claims to own unsurveyed islands in nonnavigable streams. The *Wolff* and *Koch* cases are distinguishable from the usual situation on unsurveyed islands because the notations in the field notes described

'Parcel 9' as a "bar or low islands"; 'Parcel 10'—a "long low island, overflowing and unfit for cultivation"; 'Parcel 14'—a "low overflowing island"; 'Parcel 20'—a "large island" and etc. The Appeals Court found these descriptions to imply that the Government intended the islands to pass with the title to the uplands. Although the Court held that the Government did not retain any access to the islands, such a reservation is nearly unheard of in the land disposals in the 1800s and the early 1900s. The Court further held that the Government's intention controls the disposition of land granted by conveyance, thus if the island is not surveyed by reason of mistake, error or fraud, the Federal Government is not bound by its mistakes.

The ruling found that the question as to the extent of this Federal grant, that is, as to the limit of the land conveyed is necessarily a Federal question. Nevertheless, the 6<sup>th</sup> and 10<sup>th</sup> Federal Circuits has directed the surveyor to look to State law to resolve the dispute; otherwise unsurveyed islands follow the traditional approach.

## The Island Rule (Case Studies)

**8-165(n).** The following case studies illustrate some of the various legal settings in which the island rule is an issue. Surveyors need to be aware of these situations, which may affect their resurvey work.

*Commissioners of Land Office of State of Oklahoma v. United States*, 270 F. 110 (8<sup>th</sup> Cir. 1920), *appeal dismissed*, 260 U.S. 753 (1922)



Figure 8-95. Vicinity map.

Ownership of a valuable island in an Oklahoma river was at stake. This is the same island at issue in *United States v. Hutchings*, 252 F. 841 (D. Okla. 1918). The island

would belong to the Osage Indians if it was located in the north half of the river bed when the Reservation was established. This case is a leading case under Federal holdings on the island rule.

Commissioners of the Land Office of the State of Oklahoma claimed an island in the Arkansas River on the theory that the river was navigable at the date of statehood in 1907. The State further claimed that the island was part of the bed. Aligned with the State was a group of upland owners on the south bank of the river. That group claimed the island as part of their riparian rights.

All this interest in the island was occasioned by the concentration of underground oil in the area.

At trial time the southern channel had largely filled in with sand and consisted of a few potholes such that the former island was attached to the southern bank.

The United States was defending the Osage Tribe of Indians and an allottee named Larry Nolegs.

The U.S. theory was that the main channel of the river, at the time of the establishment of the Reservation, was south from the island such that the island was included in the Osage Reservation that was on the northern bank.

The trial court found that although the main channel of the river was on the northern side of the river at the time of trial, it had been on the south side in 1872 (figures 8-96 and 8-97). The trial court found for the United States and this appeal was taken.

The original survey of the range line noted the island location as a topographic item but the subdivisional surveys disregarded the island from areas returned (an unsurveyed island situation) (figure 8-98).

In 1908 the GLO resurveyed the Osage Reservation that lay on the northerly bank. This time the island was surveyed (meaning that areas were returned on the plats) and presumably included in the Reservation.

On appeal, both sides agreed that the south channel had gradually filled in and the flow gradually diverted to the north channel.

The Appeals Court said, in part:

The general rule on this subject is: (1) That where the thread of the main channel of the river is the boundary between two estates and it changes by the slow and natural process of accretion and reliction, the boundary follows the channel; (2) but, where it changes by the sudden and violent process of avulsion, the boundary remains where the main channel was at the time of the avulsion, subject always to such changes as may be wrought after the avulsion by accretion or erosion while the old channel is occupied by a running stream. Counsel rely upon the first clause of this rule. That Clause is applicable to and governs cases where the boundary line, the thread of the stream, by the slow and gradual processes of erosion and accretion creep across

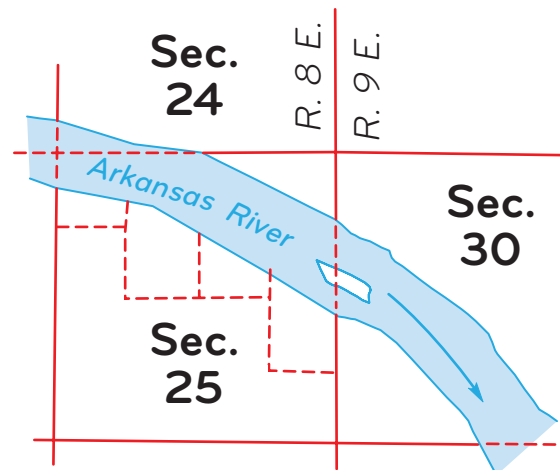


Figure 8-96. The disputed island from the original survey plats.

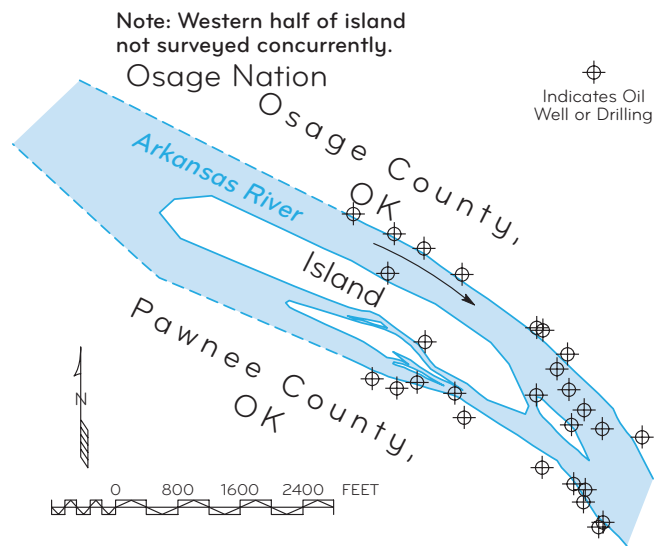


Figure 8-97. A sketch from the 1935 plat showing the oil wells near the disputed premises.

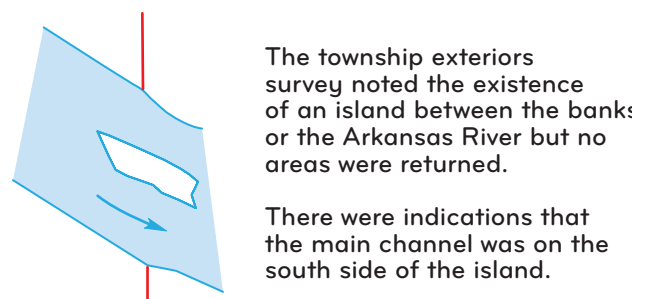


Figure 8-98. A sketch from the GLO range line survey.

the intervening space between its old and new location. To this rule, however, there is a well-established and rational exception. It is that, where a river changes its main channel, not by excavating, passing over, and then filling

the intervening place between its old and its new main channel, but by flowing around this intervening land, which never becomes in the meantime its main channel, and the change from the old to the new main channel is wrought during many years by the gradual or occasional increase from year to year of the proportion of the waters of the river passing over the course which eventually becomes the new main channel, and the decrease from year to year of the proportion of its waters passing through the old main channel until the greater part of its waters flow through the new main channel, the boundary line between the estates remains in the old channel subject to such changes in that channel as are wrought by erosion or accretion while the water in it remains a running stream. (p. 113.)

The Court found for the United States saying that the “island never became an accretion to the lands of the owners of the south bank of the river.” (p. 114.)

The important point is that the boundary in the old channel accretes and erodes until the flow ceases. The Supreme Court stated the same thing in *Arkansas v. Tennessee*, 246 U.S. 158 (1918).

Following the Decision in 1920, the GLO surveyed a portion of the disputed island. They first surveyed the part that was in Township 8 North, Range 9 East. The 1936 Art Brown GLO Survey was made at the request of the Commissioner of Indian Affairs. Clark Gumm, Cadastral Engineer of BLM, surveyed the rest of the island in 1952 (figures 8-99 through 8-101).

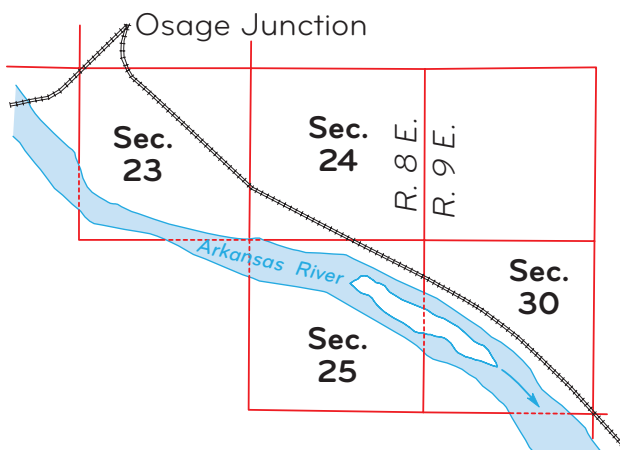


Figure 8-99. The disputed island as shown on a 1908 GLO survey.

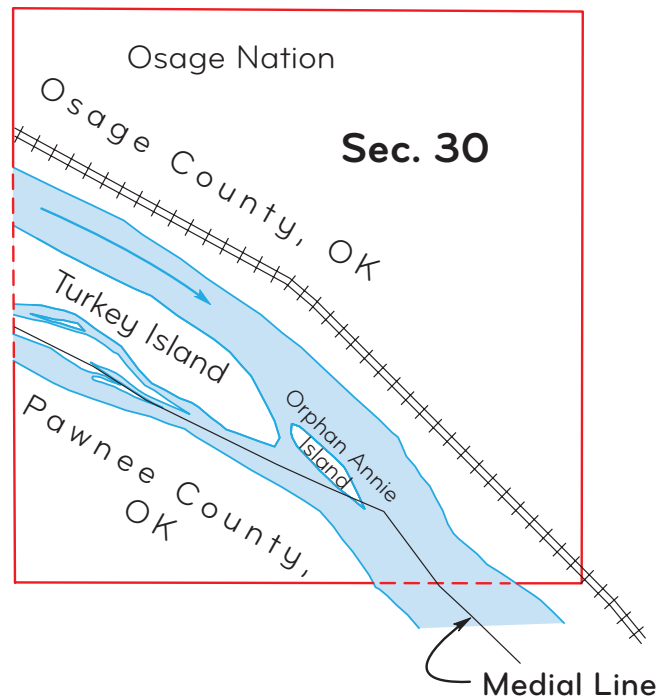


Figure 8-100. A 1952 BLM survey shows additional islands.

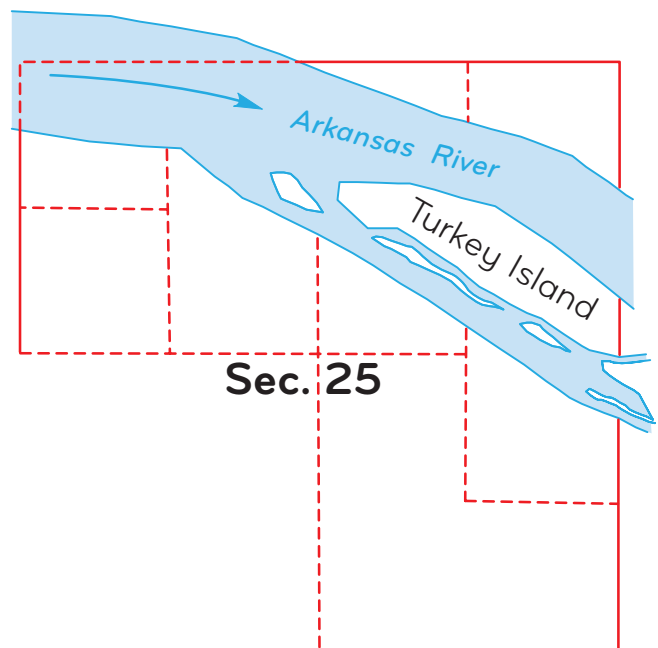


Figure 8-101. A sketch from the 1935 GLO survey to comply with 270 F. 110.

***St. Louis v. Rutz*, 138 U.S. 226 (1891)**

The case began as *Rutz v. Seeger*, 35 F. 188, in Circuit Court of the Southern District of Illinois, decided February 11, 1888. Rutz had bought his land from one August A. Blumenthal, who had acquired it in



Figure 8-102. Vicinity map.

1849. At the time of Blumenthal's purchases, the land was bounded by the Mississippi River on the narrow end of the tract (figure 8-103). This case is cited in nearly all briefs on water boundary litigation.

The tract, as surveyed, extended from the Mississippi River to the bluffs above the valley on the Illinois side, left bank, and was relatively long and narrow (figure 8-104).

Rutz's deed also included rights to an accretion or sand bar lying northwesterly of the described lands (figures 8-105 and 8-106).

The trial court found that there was "no dry ground formed in the Mississippi river in the year 1850, in front of the water's edge, as it then existed, opposite to the said land of the said Blumenthal, on the main shore." (p. 190.)

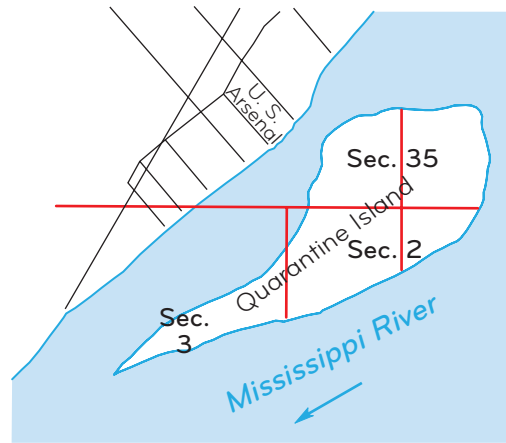


Figure 8-104. Quarantine Island in 1853. Compare the relationship to the U.S. Arsenal as shown in figures 8-105 and 8-106.

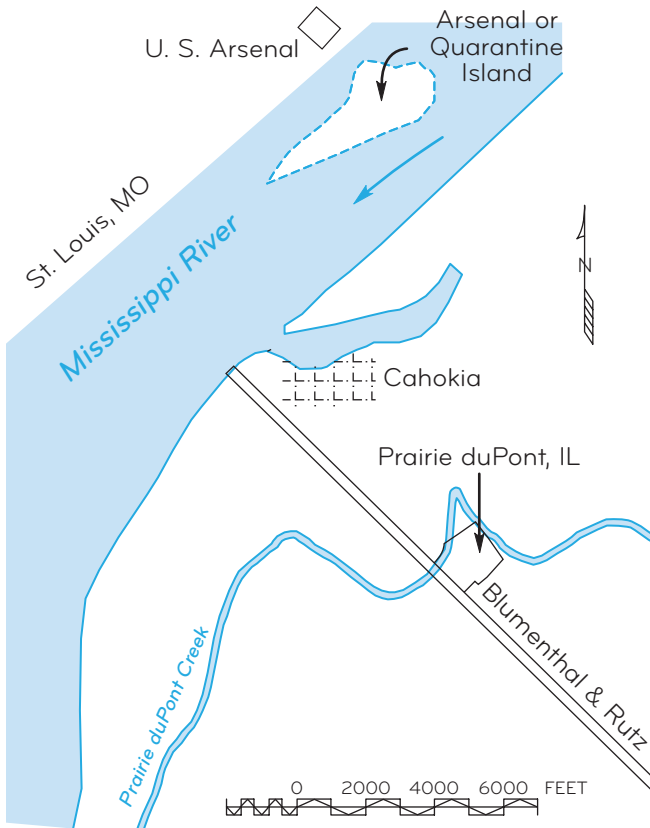


Figure 8-103. In about 1850, the Blumenthal and Rutz property was a long narrow strip that fronted on the Mississippi River.

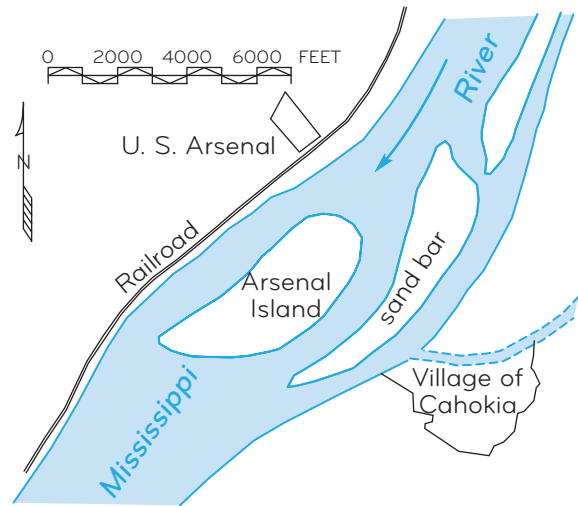


Figure 8-105. The 1862 Hutawa map shows that the island had eroded on the upstream end and accreted on the downstream end. In addition, the Mississippi River had eroded the east bank.

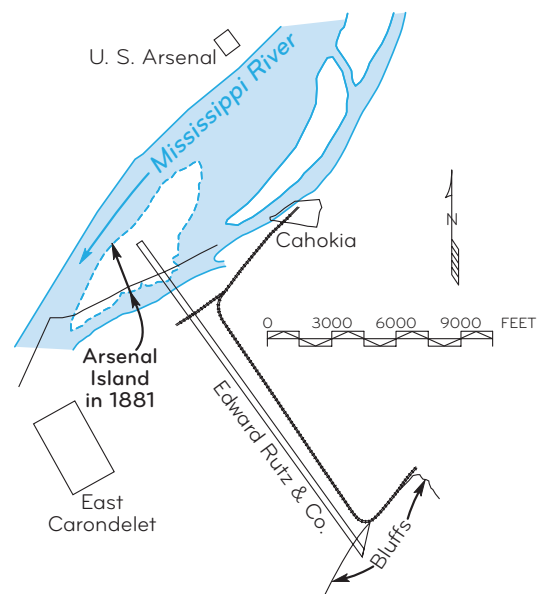


Figure 8-106. The record location of the Rutz property at the time of trial extended onto the new location of Arsenal Island.

In short, there was no island in front of his land at that time.

Also related to this case is Quarantine Island, which was used by the City of St. Louis, Missouri, for confining quarantine cases—hence the name. Because the U.S. Arsenal was nearby and the U.S. interest in the island, it became known as Arsenal Island at a later time. At low water the island would become joined to the Missouri shore.

Back in the year 1853 the City of St. Louis had acquired record title to part of Arsenal Island and leased it to Seeger who brought the original suit.

During periods of high water, erosion occurred on the upstream end of Quarantine (Arsenal) Island. Deposits of silt and even the gravels from the upstream erosion of the island itself formed on the downstream end of this island.

The complaint in the trial alleged that dikes built on the western shore of the mainland had deflected the current such that Blumenthal's land (later to become Rutz's land) had been washed away in chunks 10 to 15 feet wide. In 1872 Blumenthal began to disassemble his house because of the river's invasion. The river carried away part of the foundation eventually.

Thus we have an island eroding on the upstream end and depositing on the downstream end and at the same time the western channel of the river is widening in relation to the Illinois channel.

This situation continued until, finally, the main flow of the Mississippi was on the other, or western, side of the island and the position of the island was now over a mile downstream from its original location.

In 1876 the Government built a dike from the Illinois shore to Arsenal Island "about 60 rods northerly of Rutz's land." Also, in 1878 the Government built a dam above the dike from a point near the head of the island to the shore and from that time the flow was nearly stopped in the Illinois channel.

The Illinois channel eventually silted up below the dike by deposits from the river so that it was dry land by 1884.

Seeger claimed his lease of part of Arsenal Island was valid in spite of the movement downstream to its new position.

The above changes in the island now placed Mr. Seeger's lease from the City of St. Louis in conflict with Rutz's

land which he obtained from Blumenthal—hence the litigation.

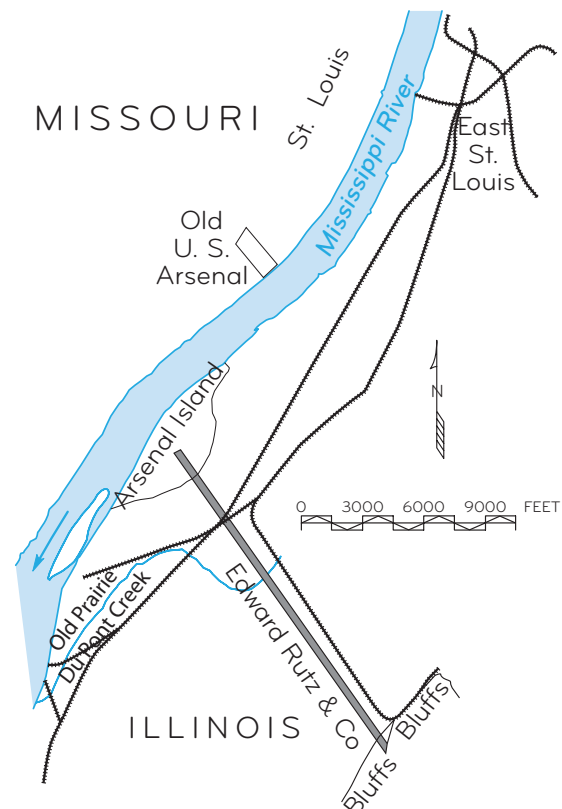
The Circuit Court found for Rutz, as well as the subsequent appeal (35 Fed. 188 (C.C.D. Ill. 1888)).

On appeal to the U.S. Supreme Court, the City of St. Louis claimed that Rutz's title did not include the bed of the river—that it was fixed by a description—and that the water line was their island's boundary no matter how far it shifted.

The Supreme Court held, first, that the State of Illinois had granted upland owners title to the bed of the river and that Blumenthal's deed gave calls to points to the low water mark and that the words "down to the extended line between surveys 156 and 157" properly meant down the river to the extended line (p. 243).

Next the Supreme Court held that, as riparian proprietor whose title includes the bed of the river, Rutz owned the land formed on the bed.

It also stated that the boundary between Missouri and Illinois was the "middle of the main channel," i.e. on the west side of the island, and that Arsenal Island was an island in Illinois not Missouri (figure 8-107). They



**Figure 8-107.** Composite map from 1974 USGS mapping. Arsenal Island is now part of the Illinois shore.



carefully excluded the situation where the river changes its main channel because the title would not change, according to the island rule. This was accomplished by saying that the Arsenal Island was only a moving mass of soil and not an island!

Finally the U.S. Supreme Court stated that, "The right of accretion to an island in the river cannot be so extended lengthwise of the river as to exclude riparian proprietors above or below such island from access to the river, as riparian proprietors. *Mulry v. Norton*, 100 N.Y. 424, 436, 437." (1885) (p. 250).

***Houston v. Thomas***, 937 F.2d 247 (5<sup>th</sup> Cir. 1991)  
***Louisiana v. Mississippi***, No. 121 Original; 506 U.S. 73 (1992), 516 U.S. 22 (1995)



Houston claimed ownership of land attached to the Louisiana bank of the Mississippi River based on an 1881 GLO patent to Island No. 94, T. 11 N., R. 9 W., Choctaw Meridian, Mississippi.

Figure 8-108. Vicinity map.

Thomas and other Louisiana owners claimed the disputed land as accretions to their property.

We study this case because the fact situation is quite similar to the facts presented over 100 years earlier in *St. Louis v. Rutz*, 138 U.S. 226 (1891), above. History really does repeat itself.

The boundary between Louisiana and Mississippi is the thalweg of the Mississippi River.

Island No. 94, also known as Stack Island, was relatively near the Mississippi bank at the time of the original survey and the location of the thalweg was an issue (figure 8-109). If the State boundary thalweg had always been located to the west of the island, the case could be resolved by the Federal District Court in Mississippi. If not, the case should be tried in Federal District Court in Louisiana. The States of Mississippi and Louisiana thus became involved in the dispute.

Houston and the State of Mississippi claimed that the State boundary was properly determined in the original 1881 survey and remained west of the island. Further, when the channel to the east widened and became the main channel, the ownership remained fixed according to the island rule. Thus, even though the disputed lands are attached to the Louisiana bank at low water, Mississippi claimed them. There was testimony that Mississippi had exercised some criminal jurisdiction over on the Louisiana side.

Thomas and the State of Louisiana presented evidence to show that the main channel of navigation was originally to the east of the island. An avulsion switched the main channel to the west of the island but a second avulsion switched the channel back to the east of the island. These and other changes, Louisiana claimed, eroded the original Stack Island. Along with the erosion, fragments of islands were claimed to form as accretions to the upland and the Louisiana-owned riverbed.

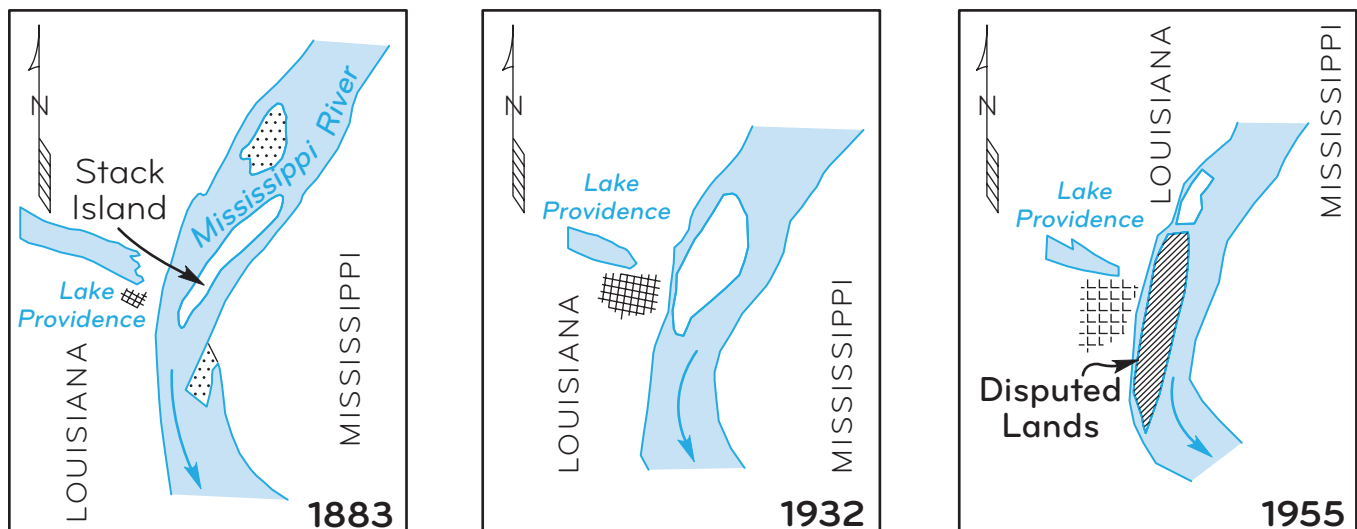


Figure 8-109. Stack Island is claimed to have moved from the Mississippi side of the river to the Louisiana bank. The 1955 position is approximate.

The trial court found that the disputed lands are presently located in Mississippi as result of an avulsive shift in the thalweg.

The State of Louisiana appealed. Louisiana also disputed the claim that Mississippi had exercised dominion over the disputed areas. The State of Louisiana requested the United States Supreme Court to take jurisdiction as an original action between the two States, but the request was denied because there were private parties on each side seeking a ruling.

The Court of Appeals examined the conflicting evidence and ruled that the trial court relied primarily on Mississippi's witness who had disregarded conclusive evidence in reaching his conclusions. The conclusive evidence he ignored was described as a hydrographic survey of the channel bottom that indicated depths adequate for navigation. Instead, the witness relied on shoreline survey information that did not show depths at all.

The Appeals Court reversed and awarded the disputed lands to the Louisiana owners.

The State of Mississippi sought Certiorari to the U.S. Supreme Court, which was granted (*Mississippi v. Louisiana*, 503 U.S. 935 (1992)).

In the meantime, all of the Louisiana owners deeded their lands and interest in the litigation to the State of Louisiana.

In December of 1992 the U.S. Supreme Court reversed the Court of Appeals, ruling that the boundary between the two States must be tried in the U.S. Supreme Court that has original jurisdiction in such matters. As to the title of the owners on each side of the river, the Court remanded the dispute for further proceedings on the factual issues (*Mississippi v. Louisiana*, 506 U.S. 73 (1992)).

In 1995 the Supreme Court ruled for Mississippi as the Court adopted the Special Master's opinion that the land once was an island in Mississippi known as Stack Island and that it therefore is part of Mississippi (*Louisiana v. Mississippi*, 516 U.S. 22 (1995)).

***Port of Portland v. Island in the Columbia River*,  
479 F.2d 549 (9<sup>th</sup> Cir. 1973)**

Sand Island formed in the Columbia River at a time after the boundary between the States of Washington and Oregon was fixed by Congress at statehood. The



Figure 8-110. Vicinity map

island first appeared on navigation charts as shoal water and as a sand bar. At the time of trial the island was used for recreation and as a source of sand and gravel (figure 8-111). It was flooded at high water.

Port of Portland is a Municipal Corporation that received a deed from the State of Oregon for the disputed land in 1970.

The name of the case indicates that the Port Authority started out to condemn the land. The defendants in the case held deeds from the State of Washington dating from 1929. The State of Washington also claimed the mineral rights under the island that they reserved in the 1929 deed.

Ownership of the island depended upon the location of the boundary between the two States at the time they were admitted to the Union. We study the case for that reason.

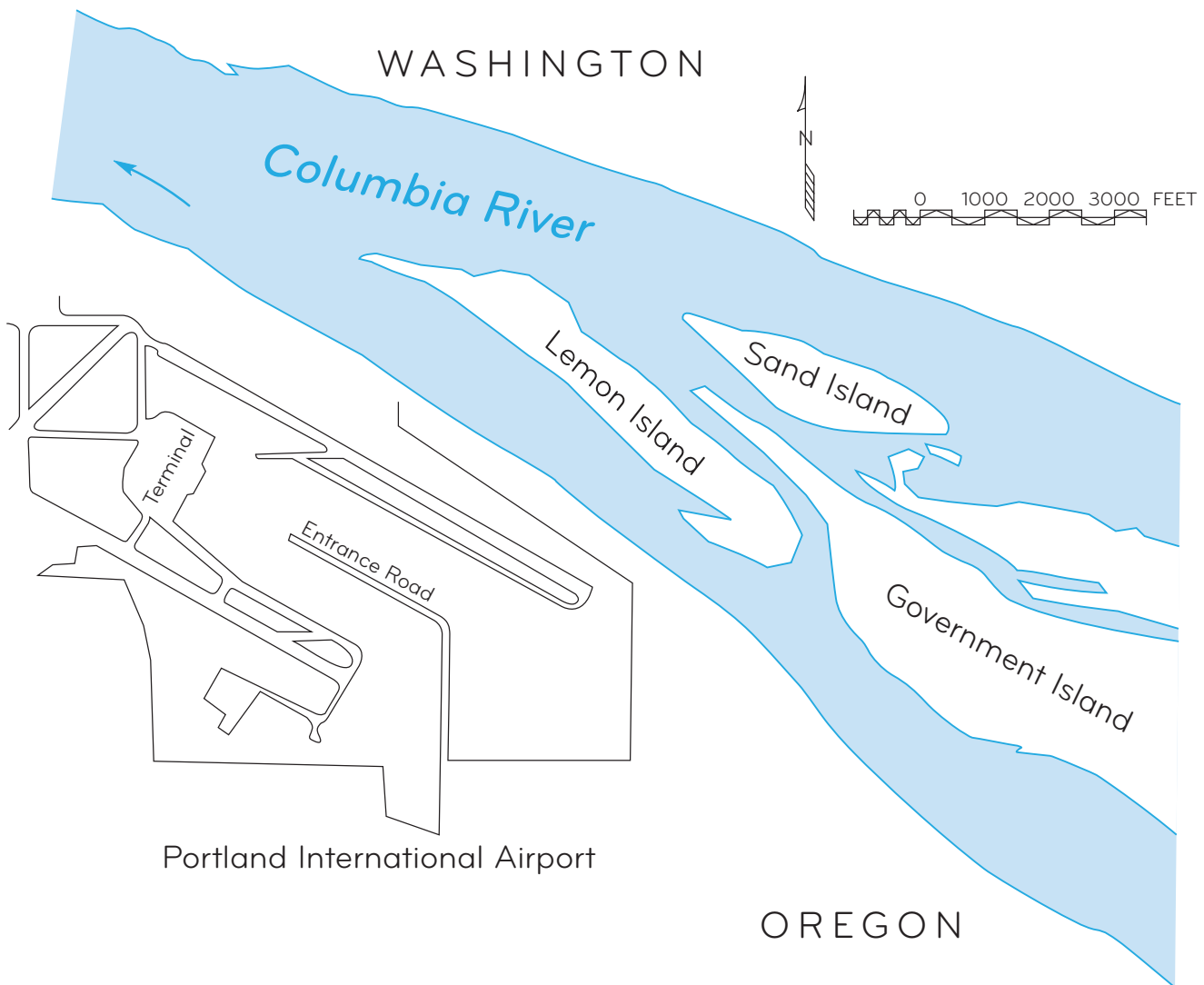
Congress described the boundary, in part, as follows: “[T]hence easterly, to and up the middle channel of said river, [the Columbia] and, where it is divided by islands, up the middle of the widest channel thereof, to a point near Fort Walla-Walla . . . .” 11 Stat. 383.

In a previous dispute between Oregon and Washington the U.S. Supreme Court had defined the “widest channel” saying that the term did not mean the broadest expanse of water. Rather, it was the widest waterway that could be used by vessels in the river.

The navigational charts indicated that the “widest channel” had always been between the Washington bank and the island although everyone agreed that the shipping had used the channel between Sand and Government Islands for a few years in the late 1920s.

The State of Washington issued its deeds at a time when the shipping channel was on the Oregon side of Sand Island under a thalweg theory.

The Trial Judge said that because the widest channel was on the north side of the island and because Congress had intended that channel to be the boundary, he would rule in favor of the Port of Portland. He held that the thalweg rule had no application to the ownership of the island and Washington's deed was issued by mistake.



**Figure 8-111.** Sand Island as shown on USGS mapping. The island was regularly submerged during high water events.

On appeal, the Appellate Court held that the “widest channel” test did not apply where the island in question was not present at the time the State boundary was described.

The Court also said:

If the island is formed by gradual deposits in midstream, it is equally well settled under the common law that the island belongs to the owner of the river bed in the place where the island arose. If the river is the boundary between two states the island would belong to the state on whose side of the middle of the main channel it was formed. (p. 552.)

Note that this holding does not divide the island at the boundary between the two States but instead presumes that the island arose in only one State and that accretions then formed to that island.

***Georgia v. South Carolina***, No. 16 Original; 257 U.S. 516 (1922)



**Figure 8-112.** Vicinity map.

By agreement, the boundary between Georgia and South Carolina was to be at the middle of the Savannah River regardless of the navigation channel. South Carolina insisted that the low water line on the southern or Georgia shore was the true boundary. South Carolina acknowledged, however, that the middle line could be used where there were no islands.

Georgia maintained that the middle of the channel should be used for the boundary as determined at the ordinary stage of the water rather than at low water position.

There was another question of control of islands and whether the low or the ordinary water line should be used for determination of the boundary where islands were present. The dispute should have been settled by a Treaty signed in 1787 by Commissioners from the two States.

The Court pointed to South Carolina's acknowledgment that the middle line could be used and that the South Carolina General Assembly repeated the phrase "middle of the river" when adopting the treaty of 1787.

The use of the south Georgia bank at low water was thus ruled out where no islands existed.

Under previous Supreme Court Decisions and international law where a navigable channel is not involved, each State's jurisdiction extends to the middle of the stream.

The river was admittedly navigable in this area but the middle had been agreed upon in 1787 and each State was to have equal rights to navigation.

The Court held that where there are no islands in the boundary rivers, the location of the line between the two States is on the water midway between the main banks of the river when the water is at ordinary stage.

The decision also defined the boundary when it passed between an island and the South Carolina shore in a similar manner and decided on the island ownership.

### Erroneously Omitted Lands (Case Studies)

**8-166(n) through 8-178(n).** The following case studies illustrate some of the various legal settings in which erroneously omitted lands are an issue. Surveyors need to be aware of these situations, which may affect their resurvey work.

*Lee Wilson and Company v. United States*, 245 U.S. 24 (1917), *aff'g*, 227 F. 630 (8<sup>th</sup> Cir. 1915), *aff'g*, *United States v. Lee Wilson and Company*, 214 F. 630 (E.D. Ark. 1914)  
*Arkansas Sunk Lands*, 37 Pub. Lands Dec. 345 (1908), *Arkansas Sunk Lands (On Review)*, 37 Pub. Lands Dec. 462 (1909)

#### Nonexistent Moon Lake

The plat of T. 12 N., R. 9 E., Fifth Principal Meridian, Arkansas, approved October 27, 1845, shows a



Figure 8-113. Vicinity map.

meandered lake occupying the greater part of sections 22 and 27, and extending a short distance into section 26. The field notes of the line between sections 26 and 27 call for an intersection with the southeast side of "Sunk Lake," here classed as impassable and navigable. The surrounding fractional subdivisions as surveyed were all patented to the State under the provisions of the swamp land grant.

The case originated on the report of the removal of timber from portions of the area under the color of title arising through the ownership of the adjoining land. The report indicated that practically all of the area was high, dry land, covered with a growth of large timber, with no difference in the character of the land from that included in the original subdivision. The topography, elevation, and timber all revealed little if any change since the date of the subdivision of the township.

The greater part of the excluded area was found to be covered with various species of oak, maple, cottonwood, hickory, sycamore, hackberry, cypress, and willow. Many of the trees were of great age, 300 years or more, and many of them indicated strictly upland site conditions. The area was found to be level land, at about the same elevation and in some places higher than the surrounding lands, though there was evidence of what had been a slough along parts of the edge of the so-called lake (figure 8-114).

By decision dated November 30, 1909, bearing departmental approval, the Commissioner of the GLO held that the area, 853.25 acres, was not a navigable lake on June 15, 1836, the date when Arkansas was admitted into the Union, nor in 1841 at the date of the subdivision of the township. As the land was in place at that period and was not permanently covered by water, it was part of the public domain, and title had not passed from the Government.

On November 5, 1917, the Supreme Court announced an opinion (*Lee Wilson & Company v. United States*) denying the merits of the riparian claims to the area within the meander line of the so-called lake, restating two legal propositions held indisputable because settled by previous decisions:

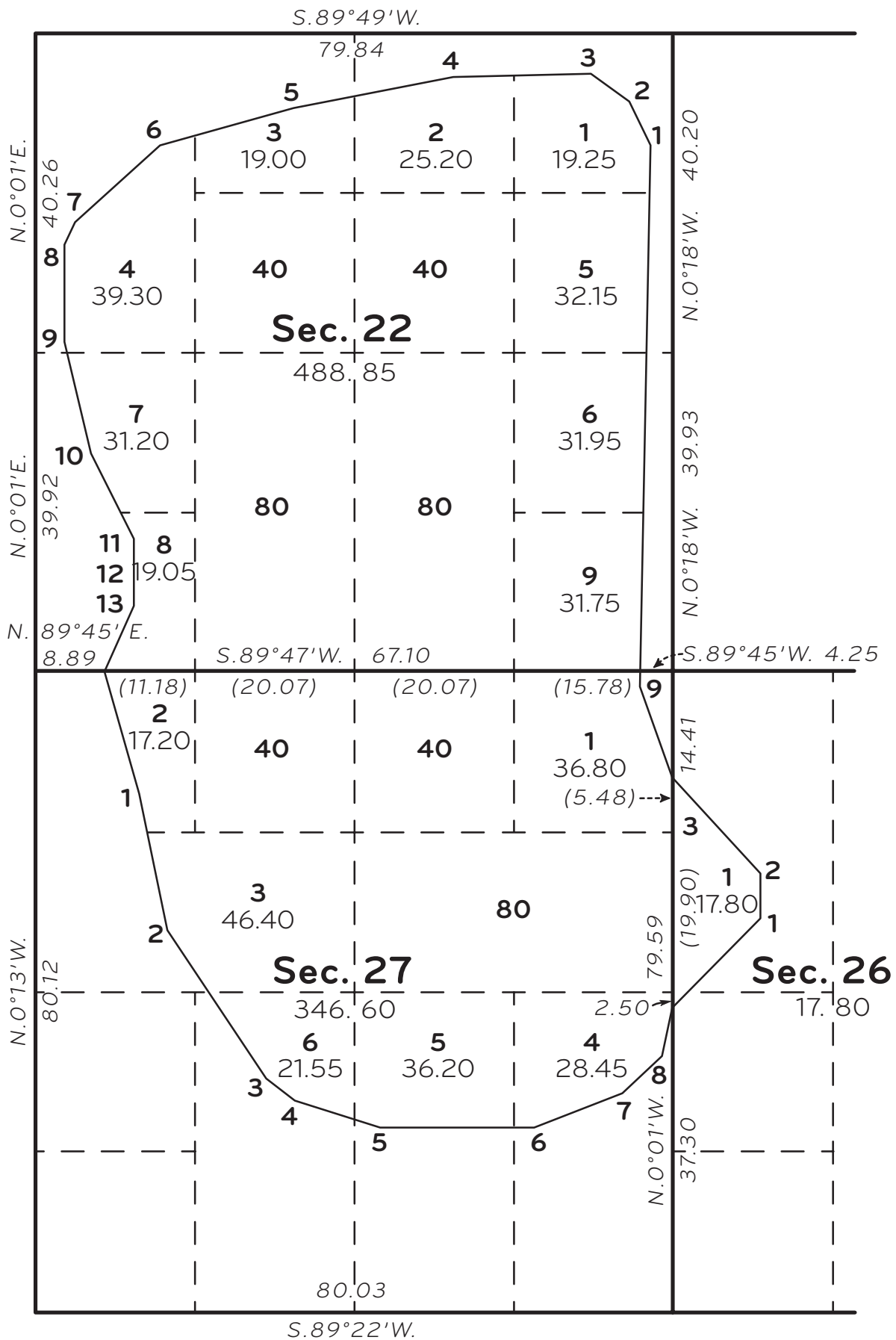


Figure 8-114. The nonexistent "Moon Lake."



*First.* Where, in a survey of the public domain a body of water or lake is found to exist and is meandered, the result of such meander is to exclude the area from the survey and to cause it as thus separated to become subject to the riparian rights of the respective owners abutting on the meander line in accordance with the laws of the several States. *Hardin v. Jordan*, 140 U.S. 371 (1891); *Kean v. Calumet Canal Co.*, 190 U.S. 452 (1903); *Hardin v. Shedd*, 190 U.S. 508 (1903).

*Second.* But where upon the assumption of the existence of a body of water or lake a meander line is through fraud or error mistakenly run because there is no such body of water, riparian rights do not attach because in the nature of things the condition upon which they depend does not exist and upon the discovery of the mistake it is within the power of the Land Department of the United States to deal with the area which was excluded from the survey, to cause it to be surveyed and to lawfully dispose of it. *Niles v. Cedar Point Club*, 175 U.S. 300 (1899); *French-Glenn Live Stock Co. v. Springer*, 185 U.S. 47 (1902); *Security Land & Exploration Co. v. Burns*, 193 U.S. 167 (1904); *Chapman & Dewey Lumber Co. v. St. Francis Levee District*, 232 U.S. 186 (1914).

Other important points in this and similar cases are found summarized in the syllabus to the *Lee Wilson* decision:

If, in the making of a survey of public lands, an area is through fraud or mistake meandered as a body of water or lake where no such body of water exists, riparian rights do not accrue to the surrounding lands, and the Land Department, upon discovering the error, has power to deal with the meandered area, to cause it to be surveyed, and lawfully to dispose of it.

The fact that its administrative officers, before discovery of the error, have treated such a meandered tract as subjected to the riparian rights of abutting owners, under the State laws, and consequently as not subject to disposal under the laws of the United States, cannot estop the United States from asserting its title in a controversy with an abutting owner; and even as against such an owner, who acquired his property before the mistake was discovered and

in reliance upon such actions and representations of federal officers carrying assurance that such riparian rights existed, the United States may equitably correct the mistake and protect its title to the meandered land. The equities of the abutting owner, if any, in such circumstances, are not cognizable judicially, but should be addressed to the legislative department of the government.

The Swamp Land Act of September 28, 1850, c. 84, 9 Stat. 519, did not convey land of its own force, without survey, selection or patent.

The surveying in the Moon Lake case consisted of a retracement of the boundaries of the several sections, a restoration of the obliterated corners, a remonumentation of all of the corners, a retracement of the record meander line with monumentation of the angle points, and a completion of the fractional section lines.

***Jeems Bayou Fishing and Hunting Club v. United States***, 260 U.S. 561 (1923), *aff'g*, 274 F. 18 (5<sup>th</sup> Cir. 1921)  
***State of Louisiana***, 47 Pub. Lands Dec. 366 (1920)



Figure 8-115. Vicinity map.

### Erroneously Meandered Ferry Lake

Ferry Lake is one of the lakes formed by the “Great Raft” of the Red River. The “Great Raft” was a complex series of logjams which probably began to form in the 15<sup>th</sup> century. Over a long

period of time the raft moved upstream as the lower end decayed and additional material lodged against the upper end. As the raft moved, it blocked off tributaries and forced the main river into new channels. Numerous lakes and bayous were formed which extended almost to the Arkansas-Louisiana State line. Ferry Lake was formed near the close of the 18<sup>th</sup> century. It was a permanent, navigable body of water in 1812 when Louisiana was admitted into the Union (figure 8-116). Because the “Great Raft” was a hindrance to navigation and transportation, Congress provided funds by the Act of May 23, 1828, to remove it. Clearing the river was a slow process, and the removal of the “Great Raft” was not completed until 1873. Most of the lakes were thereby artificially lowered or drained, and the State retained the uncovered portions of the beds. Only lands above

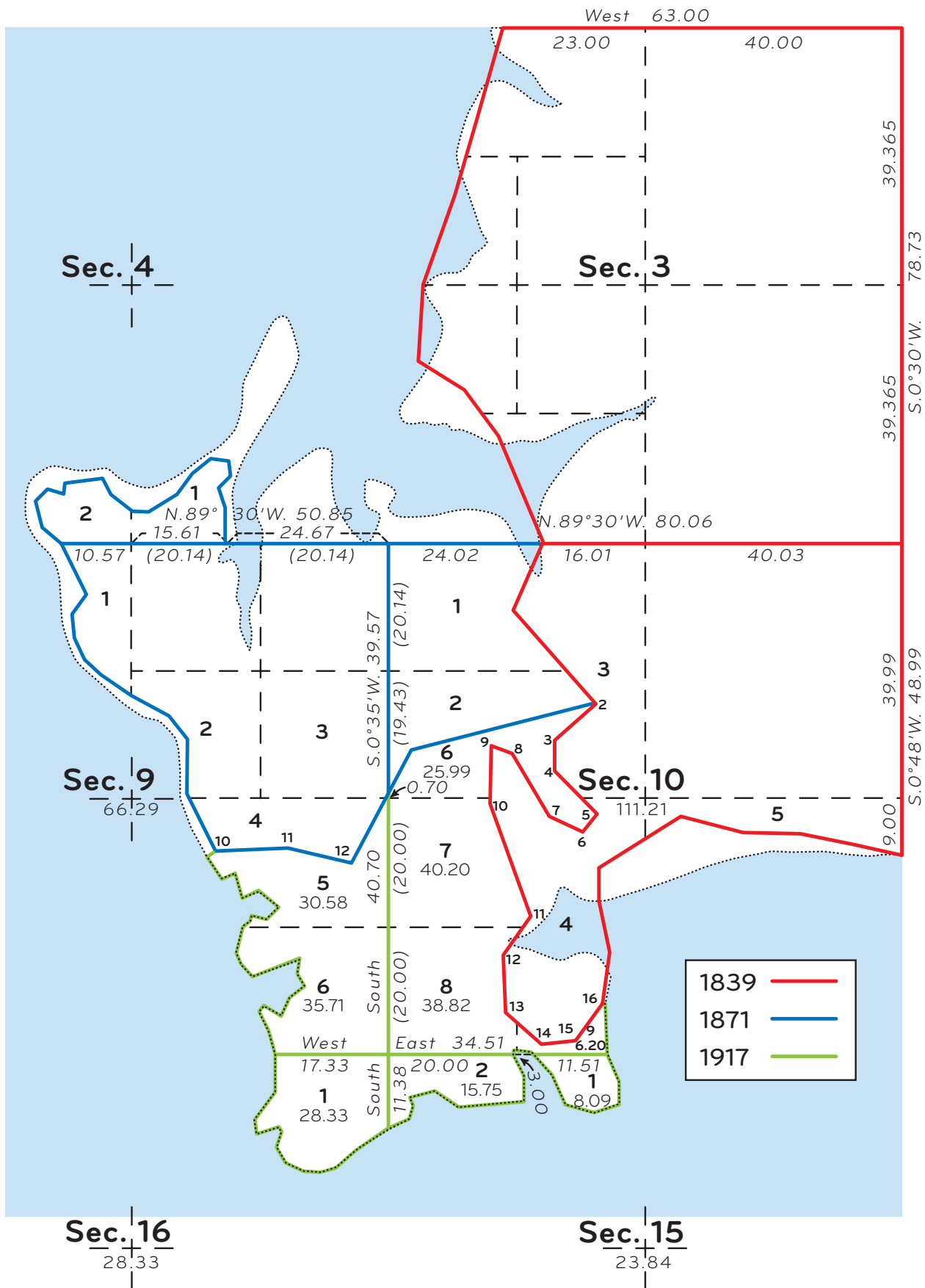


Figure 8-116. The contour representing the ordinary high water mark of Ferry Lake in 1812, when Louisiana was admitted into the Union, and in 1839, when the township was subdivided, is shown thus: .....

the OHWM before reliction were considered in determining if there had been an erroneous omission from the original survey. Location of the OHWM was one of the complications of the case.

The plat of T. 20 N., R. 16 W., Louisiana Meridian, Louisiana, approved August 31, 1839, shows the north boundary of the township discontinued on the bank of Ferry Lake (now Caddo Lake). The line between sections 10 and 11, in harmony with the remaining subdivisions, was discontinued on the lake bank, but the line between sections 3 and 10, instead of being extended to the main lake front was stopped on an arm or bay of the lake. The meander line through section 3 could be and was run with reasonable conformity, but in section 10, owing to the failure to extend the northern section boundary to the main lake front, there was no possibility of running a true meander line. Excepting the end courses, the record line, as developed, bears no proper relation to the bank as it existed at the time of the survey.

The plat of fractional sections 4, 9, and 10 of the same township, approved August 18, 1871, represents an extension of the lines between sections 3 and 10, and between sections 4 and 9, to the main lake front. The corner of sections 3, 4, 9, and 10 was established in this survey, as was a meander corner on the west side of a narrow bayou, which drains out of the north part of section 9; but again, for no apparent reason, in running south on the line between sections 9 and 10 the survey was terminated at a point more than 3,400 feet north of the bank of Ferry Lake. A part of the meander courses in sections 4 and 9 were actually run, but the remaining courses, particularly those that connected with the terminal point on the line between sections 9 and 10, were merely a traverse line through the woods, though represented in the field notes and shown on the plat to be the bank of the lake.

Following the discovery of oil and gas, mineral applications were filed with the Department in 1909 and 1910. The locations covered not only the omitted area but the bed of the lake. It was alleged that large errors had been made in running the meander lines, that the lake was merely a temporary body of water, and that it had not been navigable in 1812 when Louisiana was admitted to the Union. By 1910 all of the fractional lots adjoining the omitted area had been disposed of by the United States.

The report of the field investigation covered the historical data, the geology of the lake basin, an examination

of the forest trees, and the surveying situation. It was concluded that Ferry Lake existed as a navigable body of water in 1812, though there had been a marked recession of the lake by 1910; and that in neither of the surveys of 1839 and 1871 had the lake been correctly meandered in sections 9 and 10, either as it was at the dates of the surveys or as it was in 1812.

The soil, topography, and timber on the omitted area were the same as found on the surveyed land. Along most of the meander line there was no indication of there ever having been a lake bank or water-washed escarpment of any kind.

The forest growth on the omitted land included overcup oak, sweet gum, and red gum on the lower levels, and on the higher levels post oak, blackjack oak, Spanish oak, hickory, pine, and other varieties, many of them of great age, and clearly the descendants of a mixed forest that had existed for many centuries. The overcup oak was found in a belt immediately above a belt covered predominately by cypress, which occupied the plain terraces above and below an easily traceable escarpment. This bank, which had been made by the waters of Ferry Lake, continued without interruption around the entire basin. A contour survey showed the elevations in the omitted area in sections 9 and 10 to range up to 17 feet above the former lake level. The area omitted in these sections amounted to 229.67 acres.

Upon a review of the record, the Attorney General of the United States, in a letter to the Secretary of the Interior, dated September 11, 1916, concluded:

That no action should be taken to enforce or assert any claim by the Government to that portion of the area involved which is covered by the waters of the lake because if the State's title by virtue of its sovereignty should fail for any reason, I see no way of successfully resisting her claim under the swamp land grant.

However, in so far as concerns the land lying between the old meander line and the waters of the lake, I entirely agree with you that it constitutes unsurveyed public land of the United States, and . . . .

On January 2, 1923, the Supreme Court of the United States announced an opinion (*Jeems Bayou Fishing & Hunting Club v. United States*), denying the claims to the land in sections 9, 10, 15 and 16, adverse to those of the Government, and commented:

The inaccuracy of the plat is plainly apparent upon a like inspection. Why Warren made the survey and returned the plat as he did is a matter of speculation, but the facts demonstrate that no survey of the large, compact body of land, which includes the tract in controversy, was ever made. The circumstances, as well as the extent and character of the lands, necessitate the conclusion that the omission was of deliberate purpose, or the result of such gross and palpable error as to constitute in effect a fraud upon the Government. p. 563.

Surveying the Ferry Lake case consisted of the steps mentioned in the Moon Lake case, also a monumentation of the contour that agreed with the evident OHWM of the lake as it was in the year 1812.

***Crooked Lake and Bear Lake, Letter from Commissioner of the General Land Office (April 16, 1923)***



Figure 8-117. Vicinity map.

The plat of T. 43 N., R. 6 E., Fourth Principal Meridian, Wisconsin, approved April 6, 1863, shows a meandered lake in section 36. Meander corners were established regularly on the south and east boundaries of the section. The field notes show the running of meander courses through

the section on opposite sides of the lake, and call for high banks, along timbered land. No mention is made of an arm of a lake extending northwesterly into section 25. The fractional lottings were disposed of according to the representations of the plat.

By letter dated April 16, 1923, the Commissioner of the GLO advised the Secretary of the Interior of an application to make a forest lieu selection for the NE¼SW¼ sec. 36 (lot 15, figure 8-118), which according to the representations of the township plat would be located entirely within the bed of the meandered lake as above described. This letter contains a review of the facts as developed by a field examination, and concludes with a recommendation that the land theretofore shown as a meandered lake be surveyed and a proper plat constructed. The proposed action bears departmental approval.

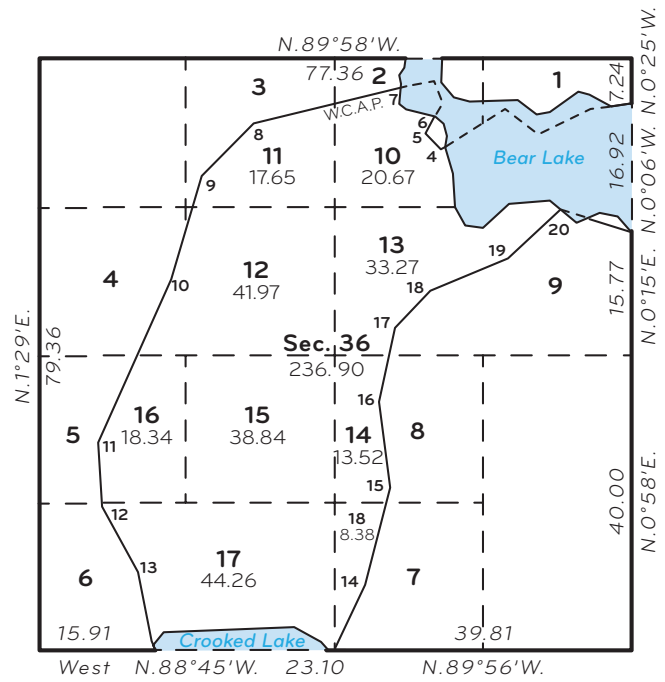


Figure 8-118. The Crooked Lake and Bear Lake case.

The report of the field examination showed the following facts:

The south and east boundaries of the section cross two lakes instead of one, the lakes being separated by a body of land amounting to 236.90 acres contained within the lines represented on the original plat as the banks of the one meandered lake. This area is rolling upland ranging up to 50 feet above the level of either lake, and forested with pine, hemlock, birch, maple and spruce timber. There was no evidence of any changes in the water level of the lakes, nor of any escarpment along the fictitious meander courses connecting them, these lines having been found to traverse rolling land instead of following a contour, with not the slightest difference between the character of the land, soil, or timber on the area theretofore surveyed and that which had been omitted. The shores of the two lakes were well defined, with banks from 3 to 8 feet high, bordered by a strip of level land from 10 to 30 feet in width, surrounded by rolling hills. The geologic formation, as well as the forest trees, indicated great age.

The surveying work to be done consisted of the steps previously outlined in the Moon Lake case.

## Accretion Prior to Entry: The Basart Doctrine (Case Study)

**8-179(n) through 8-181(n).** The following case study illustrates some of the various legal settings in which the Basart Doctrine is an issue. Surveyors need to be aware of these situations, which may affect their resurvey work.

*DeBoer v. United States*, 470 F.Supp. 1137 (D. Alaska 1979), *rev'd on other grounds*, 653 F.2d 1313 (9<sup>th</sup> Cir. 1981)



Figure 8-119. Vicinity map.

In Alaska, some upland lots were originally surveyed in 1920 and contained 165.05 acres. Thirty-nine years later DeBoer made entry on the lots in question and was granted a patent in 1961 (figure 8-120).

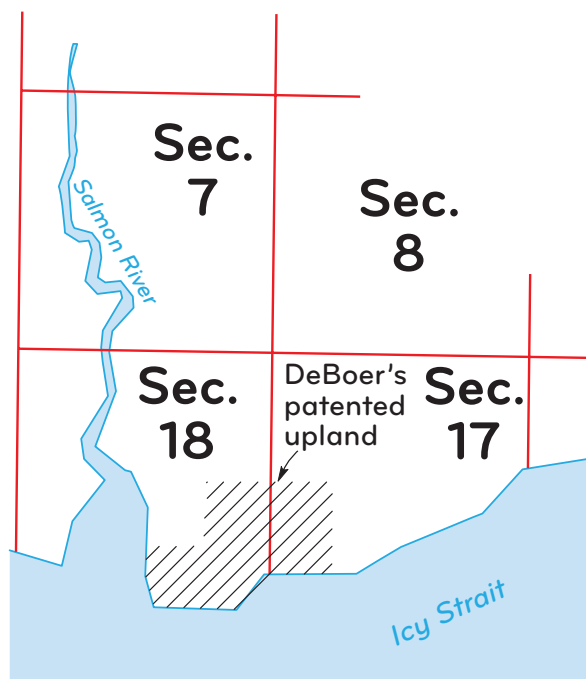


Figure 8-120. Accretions formed after the time the original plat was surveyed.

Between the time of the 1920 survey and the entry, some 105 more acres had been added by naturally occurring accretions. By 1977, an additional 107 acres had accreted, making the total acreage held by DeBoer at about 377 acres (figure 8-121).

The extra land was discovered by the State of Alaska. Under a law granting Alaska rights to select lands as a Federal grant, the State selected the accretions in front of DeBoer's patented lots.

When the United States agreed with the State that the lands, indeed, were federally owned and subject to State selection, DeBoer went to court to quiet his title. The Trial Judge's decision describes the history of the subject from the original *Madison v. Basart* case (59 Interior Dec. 415 (1947)) through *Wittmayer v. United States*, 118 F.2d 808 (9<sup>th</sup> Cir. Mont. 1941), *Smith v. United States*, 593 F.2d 982 (10<sup>th</sup> Cir. 1979) an Oklahoma case where large accretions had formed after the survey but before entry and patent and finally *United States v. 11,993.32 Acres of Land in North Dakota*, 116 F.Supp. 671 (D. N.D. 1953).

After expressing his own (the Judge's) disapproval of the Basart Doctrine, the Court recognized that *Wittmayer* was an Appellate Decision and that he was compelled to follow it.

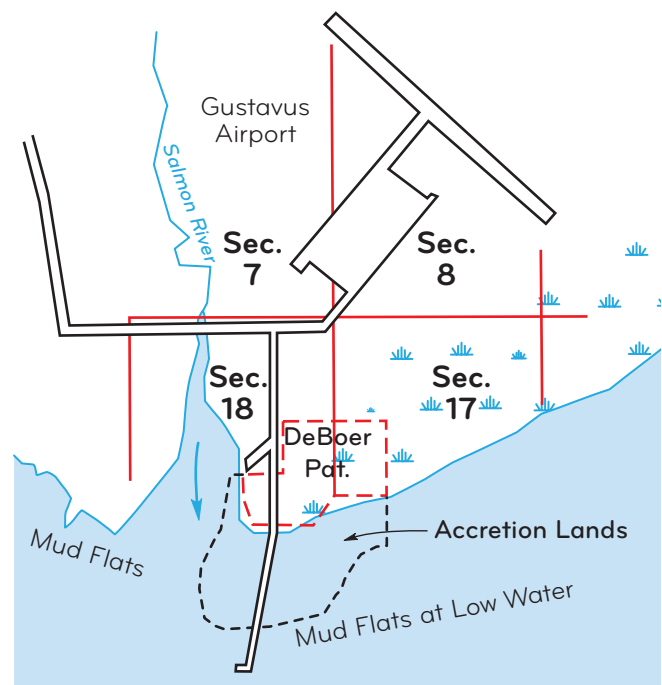


Figure 8-121. Naturally occurring accretions forming uplands after survey and prior to entry.



From the Decision, “The only question left to be decided is whether the 105.22 acres added to the 165.05 acres lot between 1920 and 1959 is ‘substantial.’ As noted above there is little to guide the courts in deciding what is ‘substantial.’ The United States Manual of Surveying Instructions (1973) at 172 states that:

In determining what constitutes a ‘substantial’ accretion, to which the rule in *Madison v. Basart* is applicable, the area of accretion should be compared quantitatively with the riparian lots to which it is attached. Some consideration should also be given to the total area accreted. Accretion to a small lot might be large in proportion but negligible in absolute size. From the standpoint of Size and Relative size, the area in question can be weighted as in the case of omitted lands.

After quoting the Manual as authority, the Court found that the 105 acres was substantial and awarded the land to the Federal Government as well as the 107 acres that accreted afterward.

Notice that the additional 107 acres of land accreted after Entry and before 1975 was not at issue in the decision as to the “substantiality” but was included in the judgment.

The appellate court confirmed the Judge’s decision and expanded on the substantial accretion exception rule by including weighing of equity factors, such as unjust enrichment. The Court expressed its disagreement with an application of a substantial accretion exception based solely upon purely quantitative factors. “We note, however, that even in *Madison v. Basart* itself, equitable factors such as the landowner’s knowledge of a discrepancy and lack of any risk to the particular landowner involved were considered.”

### Land Outside Meanders with No Gross Error in Survey (Case Study)

**8-182(n) through 8-186(n).** The following case study illustrates some of the various legal settings in which land outside meanders with no gross error in survey is an issue. Surveyors need to be aware of these situations, which may affect their resurvey work.

***Walton v. United States*, 415 F. 2d 121 (10<sup>th</sup> Cir. Wyo. 1969)**

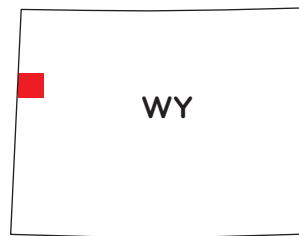


Figure 8-122. Vicinity map.

Walton owned riparian lots along the Snake River in Wyoming, which were located on bench land overlooking the river. The record area of the lots was 111.55 acres. Between Walton’s lots and the river were an additional 323.59 acres of relatively flat pasture land containing large cottonwood trees. Some of the trees were dated to a time before the original surveys were executed.

The Government brought suit in 1967 claiming the 323 acres as erroneously omitted lands. The suit was initiated because Walton had prevented Government surveyors from restoring the meander line.

At a District Court trial the witnesses for both sides agreed that the river could not have been located at the meander line (figure 8-123). In the findings of fact the Court said:

By superimposing the meander lines established by the GLO original surveyors Owens and Voight on an aerial photograph of the area made in 1960, it is immediately apparent that the meander lines do not even superficially define the sinuosities of the main channel [of the river] nor approach the line of mean high water.

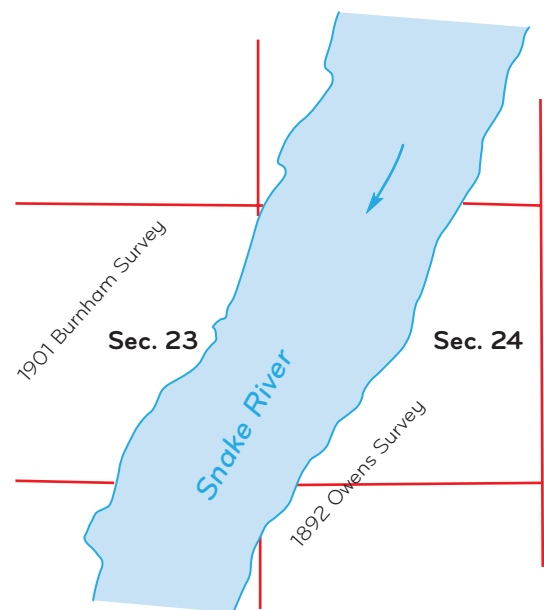


Figure 8-123. The Snake River was shown on the original GLO plats as about one-half mile wide although trees were growing in the river bed area at the time of the survey, according to tree-ring dating.

*United States v. Walton*, 266 F.Supp. 257, 261 (Wyo. 1967) (figure 8-124).

The trial court went on to describe the meander line as traversing over hills and along a bench that was as much as 140 feet above the river.

The Snake River in this vicinity is a fast flowing mountain stream, which runs through a bed of large cobbles. As such it did not erode rapidly in its natural state. Normal runoff in the spring would, however cause the Snake River to occupy many small intertwining channels paralleling the main stream. These small channels were typical of a braided stream when the river was at higher flows (figure 8-125). During the low flow summer months the river occupied only the main channel.

The field notes of the Owens survey describe the difficulties he had with deciding where the bank of the Snake River was located. By retracing the meander locations along the entire townships surveyed by Owens and Voight, it becomes clear that the original surveyors called the outermost braid of the river, at that time, the bank of the river (figure 8-126).

The trial court held that the 323 acres of land were omitted lands that belonged to the United States; Walton appealed.

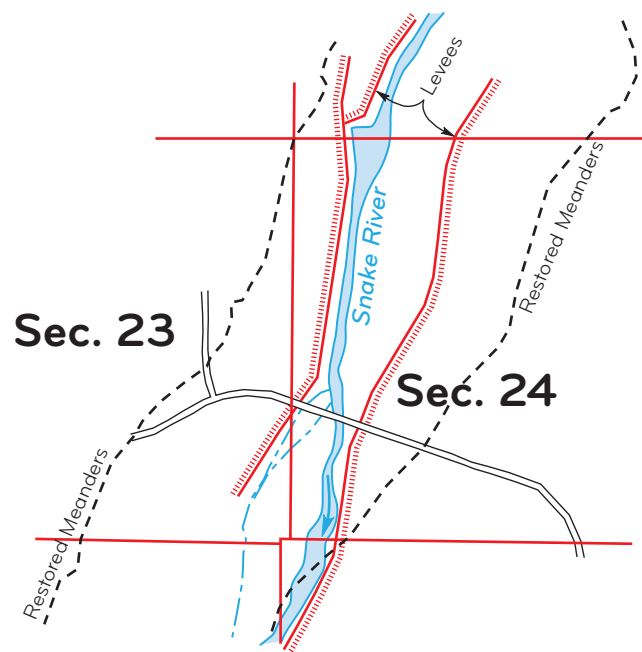
The Appellate Court held that the finding of the trial court met the “substantial area” test. The finding was based on the evidence of the age of the trees and because witnesses on both sides agreed it was possible that the surveys did not follow the river bank.

The Appellate Court affirmed the trial court decision. The land belonged to the Government.

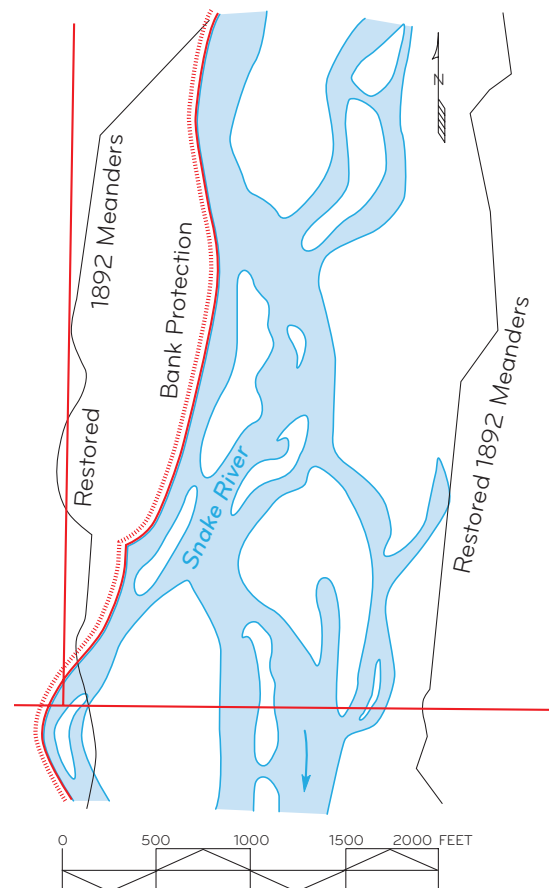
There are many miles of perfectly valid original meanders in the United States that are 100 feet or more up a steep slope above the water.

If there was an outer braid of the river at the base of the 140 foot bench land, then there must have been an island between that outer braid and the main channel of the river. That island would have been an unsurveyed island, which may also have belonged to the United States so that the ultimate effect on the ownership might have been the same as the Appellate Court’s finding.

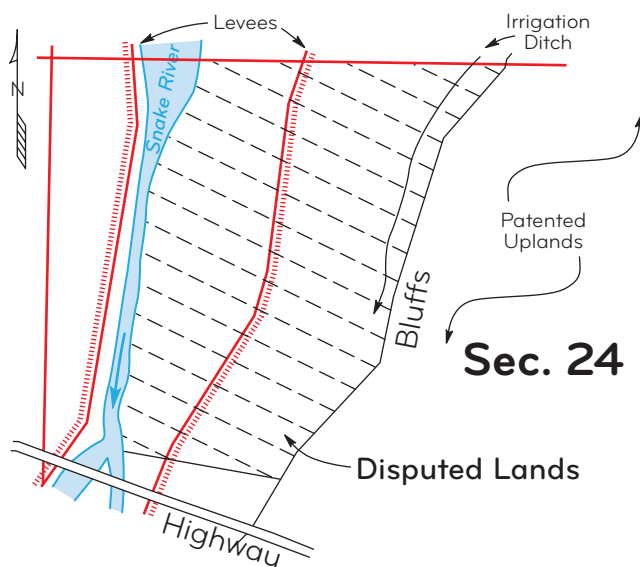
What evidently happened is that the Government was able to convince the Court that the lands were omitted



**Figure 8-124.** A vicinity sketch taken from a 1960s survey by the BLM; which restored the meanders of the original surveys and claimed the entire area between the meanders as Federal interest lands. The survey was eventually cancelled. Note that the river has been squeezed between levees by a flood control project.



**Figure 8-125.** A portion of section 32, T. 42 N., R. 116 W., 6<sup>th</sup> P.M., Wyoming, from 1963 photographs. All areas between opposite restored 1892 meander lines were claimed as omitted lands.



**Figure 8-126.** A sketch showing the approximate location of the low bluff where the meanders were located and the irrigation ditch directly below the bluff. The original surveyors had actually meandered the outer braid of the river. The Owens and Voight survey was not erroneous in light of all the facts.

when the land was actually an unsurveyed island that had become attached to the upland lots. The difference is that Owens and Voight were widely known to have been reliable surveyors and there was no error or fraud in their surveys.

*Walton* highlights the principles that (1) the official plat is part of the instrument of conveyance, (2) in a public grant nothing passes by implication, (3) in a public grant a construction shall be adopted that favors the sovereign, and (4) the substantial area test is applied to determine if omitted lands are extant.

### Mineral Lands Survey and Water Boundaries (Case Study)

**8-187(n) through 8-189(n).** The following case study illustrates some of the various legal settings in which water boundary of a lode mining claim is an issue. Surveyors need to be aware of these situations, which may affect their resurvey work.

*Alaska United Gold Mining Co. v. Cincinnati-Alaska Mining Co.*, 45 Pub. Lands Dec. 330 (1916), *reh'g denied*, 45 Pub. Lands Dec. 344 (1916)

Alaska United Gold Mining Company had patent for lode mining claims that lay along the Gastineau Channel, a navigable body of water. Accretions, which probably contained gold, had occurred between the mineral



**Figure 8-127.** Vicinity map.

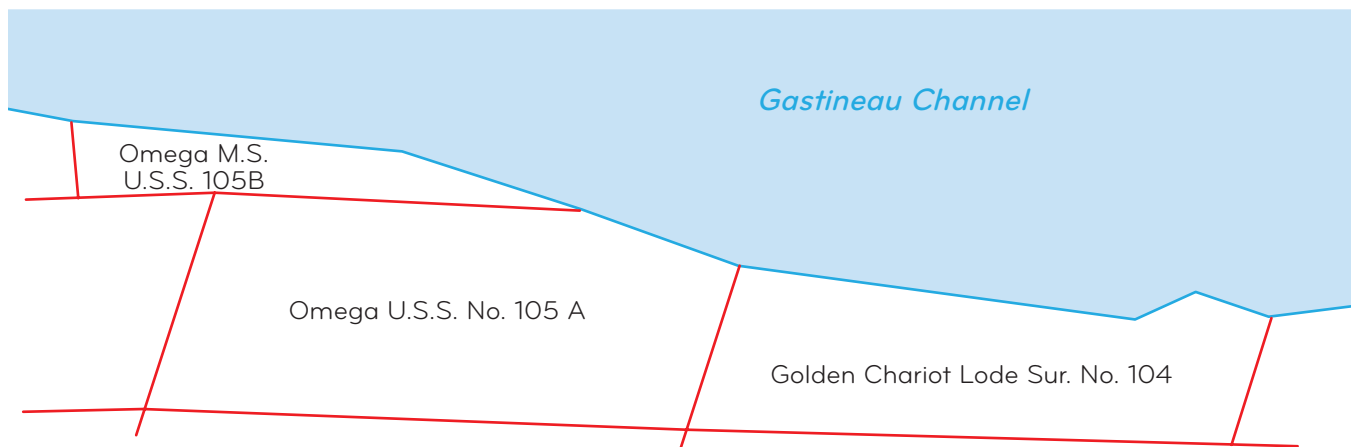
survey meander line and the line of MHT, and adverse claimants located mining claims on the lands formed by accretion. Alaska United argued that the lands conveyed under the patent were bounded, as described in the plat and field notes, by the meander line and thus included the accreted lands; consequently those lands were not open to location by the adverse claimants. See *id.* at 333. The adverse claimants argued that the description in the patent only mentioned the water's edge of the channel at one corner, and that the plat and field notes were not admissible to explain the patent description. *Id.* at 338. The Assistant Secretary disagreed, showing that the plat corresponding to the patent showed the area of the grant to lie along the meander line for several courses (figure 8-128). The field notes also described the meander line on those courses.

The Assistant Secretary held that the references in the patent to the plat and field notes were sufficient to admit them as evidence for the purpose of showing that certain lines of the survey supporting the patent were meander lines. *Id.* at 339. Consequently, the Assistant Secretary found that the patented lands included the accretions because the lands conveyed were bounded by the line of MHT, as depicted by the plat, which corresponded to the meander line of the original survey.

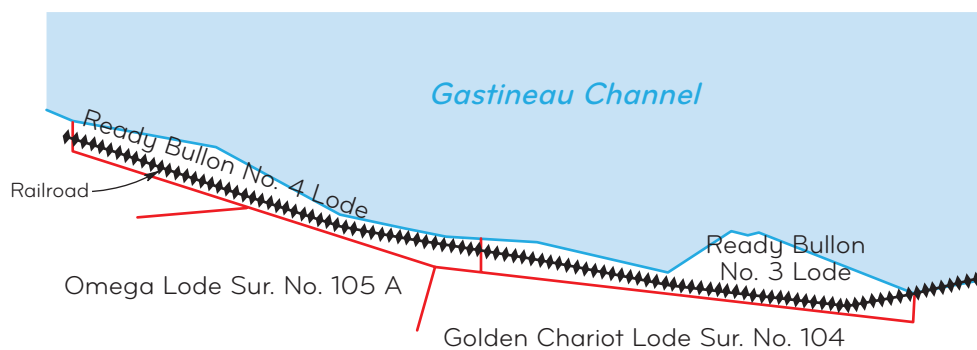
As the Assistant Secretary stated:

It has been repeatedly held by both State and Federal courts that plats and field notes referred to in patents may be resorted to for the purpose of determining the limits of the area that passed under such patents. In the case of *Cragin v. Powell*, 128 U.S. 691, 696 (1888), the Supreme Court said:

It is a well settled principle that when lands are granted according to an official plat of the survey of such lands, the plat, itself, with all its notes, lines, descriptions and landmarks, becomes as much a part of the grant or deed by



The Omega and Golden Chariot Patented Lodes were platted as riparian to the channel.



The rejected claims were squeezed into a 120 ft. average width between the channel and the patented lodes and mill site.

**Figure 8-128.** After accretions formed and a railroad was constructed, adverse claimants moved onto the accretions.

which they are conveyed, and controls so far as limits are concerned, as if such descriptive features were written out upon the face of the deed or the grant itself. *Alaska United Gold Mining Co. v. Cincinnati-Alaska Mining Co.*, 45 Pub. Lands Dec. at 336.

In other words, it can be assumed that patents were issued upon the surveys made under the direction of the United States surveyor general and a reference in a patent to the official plat and survey makes such plat and field notes of such survey a part of the description of the land granted, as fully as if they were incorporated at length in the patent.

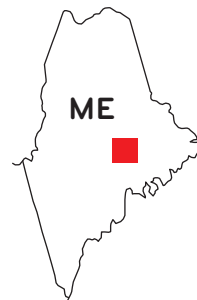
### Acquired Lands and Tidal Waters (Case Studies)

**8-190(n) through 8-195(n).** The following case studies illustrate some of the various legal settings in which

division of tidewater flats is an issue. Surveyors need to be aware of these situations, which may affect their resurvey work. The case studies on pages 272 to 282 are used by permission from *Water Boundary Problems . . . Resolved*, by Donald A. Wilson.

### Maine Cases

#### *Emerson v. Taylor*, 9 Me. 42 (1832)



**Figure 8-129.** Vicinity map.

The Massachusetts Colonial Ordinance of 1641 was found to apply in Maine.

The particular problem solved in this case was the manner in which the side lines of the riparian lots were to be extended to the low water mark. Taylor, owner of lot number 5, claimed that his side lines should be extended to low water mark, which

would deprive Emerson, owner of lot number 6, of most of his division of the flats. The Court decided that they could not rationally decide the question solely between the parties to the suit, so it included the entire block in its decision (figure 8-130).

The decision was, for each lot, to draw base lines that extended from one lot corner on the high water mark to the other lot corner on the high water mark. Then draw perpendiculars to the base lines at each lot corner. The next step was to bisect the angles between each pair of perpendiculars at each corner. The bisectors are shown as solid lines (figures 8-131 and 132).

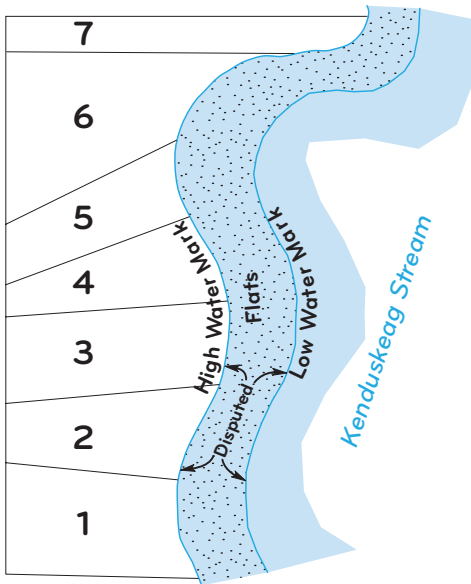


Figure 8-130. Division of the flats was in dispute.

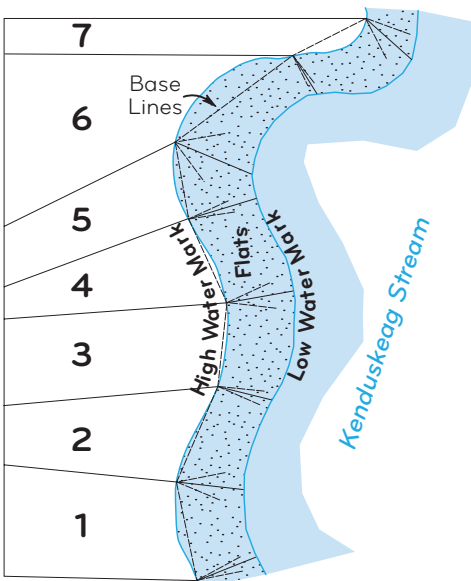


Figure 8-131. The Court's solution bisected angles between adjacent perpendiculars.

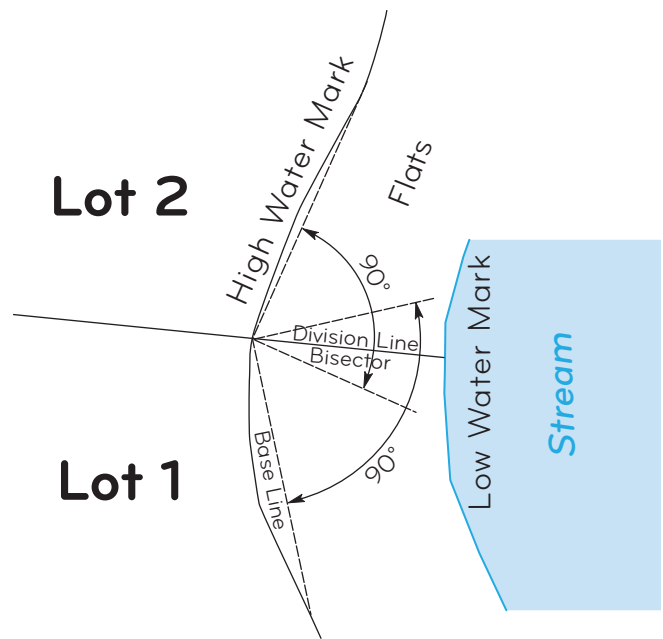
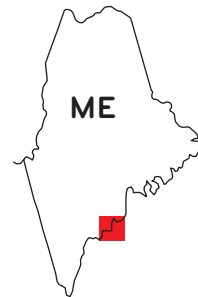


Figure 8-132. Detail showing how the angles were bisected.

**Whitmore v. Brown & Gilley; Smallidge et al. v. Brown & Gilley, 100 Me. 410 (1905)**



Gilpatrick's Cove on Mt. Desert Island off the coast of Maine was owned by John Barnard and Maria Teresa De Gregoire in common and undivided. In 1788, under a partition hearing, the easterly part of the island was set off to Madame De Gregoire in severalty, i.e. in her own right.

Figure 8-133. Vicinity map.

The first question was whether Madame De Gregoire owned the flats. The Court stated that a deed could withhold title to the flats in a conveyance but that specific terms of the grant are required to give effect to the intent of the grantor to withhold the flats (figure 8-134).

The Court stated that, in a deed, the words "to the shore" is a phrase of exclusion. For example, it held, "to the shore and then by the shore" unqualified, excludes the shore, which is the flats between high and low water mark. But if the description begins or ends at the low water mark then the shore will be included.

The following language is from the Court's decision:

The *Whitmore* Case. The boundary in the last named deed is as follows: "Beginning in the



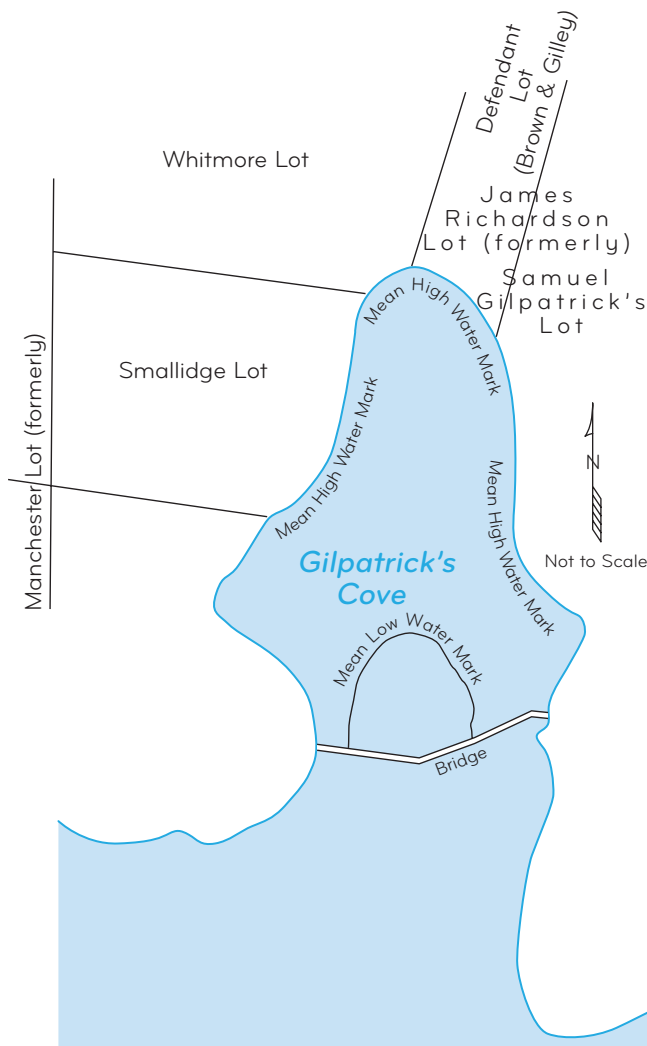


Figure 8-134. Gilpatrick's Cove.

N.E. corner of Nathan Smallidge's land; thence running W. on Smallidge's line to the shore at the mouth of Somes's River; thence N. Westerly to a stake south of Thomas Manchester's wharf; thence E. to Samuel Gilpatrick's line; thence south on Gilpatrick's line to the head of Gilpatrick's Cove; thence around the western side of the cove to the first mentioned bounds." The Gilpatrick line spoken of is the same as the Richardson line in the older deeds.

The question is, — Does the line "to the head of Gilpatrick's Cove," end at high water mark? Or does it extend to or toward low water mark? We think it ends at high water mark. The words "head of the cove," in their natural significance, seem to us to mean that place farthest up the cove where the water stands at high water, and not down the cove at low water mark, a place

which in this case is near the mouth of the cove. Moreover the plans in evidence in this case show that the Gilpatrick line, if extended across the flats in the cove, would strike the upland on the westerly side before it would strike low water mark, and then it would be on the outside of the cove. The words, "to the head of the cove" exclude the cove and the flats. The next call in deed strengthens our conclusion. It is, — "thence around the western side of the cove to first mentioned bounds." It helps to make clear what was in the minds of the parties. If "the western side of the cove" starts at the Gilpatrick line at high water mark, and proceeds along high water mark, the course seems a reasonable, natural and probable one. On the other hand, if the Gilpatrick line be extended southerly across the flats, the next call, "around the western side of the cove," has little or no meaning. There is no place which it fits. It seems very improbable that the parties actually intended the conveyance to cover anything below high water mark. A glance at the sketch is sufficient to show how improbable it is that such a line was intended. There is another ground which also seems to us conclusive that the deed in question did not convey the flats. The description begins "at the N.E. corner of Nathan Smallidge's land," and it ends at "the first mentioned bounds." As we shall show when we consider the Smallidge case, the Smallidge land did not include the flats. The northeast corner of the Smallidge land, therefore, was at or above high water mark. So that the description in the Whitmore deed now in question begins at a point at or above high water mark, proceeds by several courses to the head of Gilpatrick's Cove, thence around the western side of the cove, to the point of beginning, which was at or above high water mark. Such a description, in the absence of other calls or circumstances showing a contrary intention, will be construed as excluding the shore. *Parker v. Dunton*, 97 Maine, 461. To hold otherwise would be to ignore all the previous decisions of this court. The plaintiff's grantor therefore obtained no title to the flats by grant, and conveyed none to her.

The *Smallidge Case*. The plaintiffs' lot lies next south of the Whitmore lot just considered, and they have the title which was conveyed to Nathan Smallidge by Wentworth Kenniston, by deed dated December 11, 1839. The description in that deed is as follows:—"Beginning at

a spruce tree on the shore near the head of Gilpatrick's Cove, so called, on Mt. Desert Island and running west across the point to the shore; thence south Easterly and northwardly running the shore to the point of beginning, with all the privileges thereto." It must be considered that the spruce tree which was "near the head of the cove" and which was both the beginning and the ending of the boundary as expressed, was on upland. And although it may properly be held, under some circumstances, that a tree or other object on the bank of a river or cove, which marks the starting point of a boundary line, is intended rather to mark the course of the line than its precise terminus, at water line, and even that flats beyond may pass, *Erskine v. Moulton*, 66 Maine, 280, we do not think such a rule can be applied to the description in this case, so as to carry the starting point to low water mark, particularly since the other calls in the deed exclude the shore. They are, "running west across the point *to the shore*; thence . . . running the shore to the point of beginning." As we have already said, "running the shore" means "running by the shore." These calls exclude the shore. *Proctor v Maine Central R. R.*, supra. And the whole description is brought within the rule that where the two ends of a line by the shore are at high water mark, in the absence of other calls or circumstances showing a contrary intention, the boundary will be construed as excluding the shore. Moreover, a glance at the sketch will show the improbability that the parties intended the northeast corner of the lot to be at low water mark.

It is admitted that in all the deeds the words, "together with all the privileges and appurtenances thereto belonging," are inserted in habendum clause. And in the Smallidge deed the description of the premises granted is followed by the words "with all the privileges thereto." The plaintiffs claim that the flats are appurtenant to the upland, and that under such descriptions, or clauses, they passed by a conveyance of the upland. It was suggested in *Snow v. Mt. Desert Isl. R. E. Co.*, 84 Maine, 14, that flats are in a sense considered as appurtenant to the upland. But it must be remembered that the effect of the Colonial Ordinance upon the construction of deeds is merely to fix boundaries. A deed of the upland prima facie conveys flats,—not appurtenances nor privileges merely, but the

land itself, subject to public uses,—to low water mark. On the other hand, we think it must be held that if by the descriptive terms in the deed, the flats are excluded, they do not pass even as appurtenances or privileges. They are outside the boundaries fixed by the deed. No interest in land in the flats passes which is beyond the dividing line.

The entry in each case was judgment for defendants (pages 414-417).

### Massachusetts Cases

***Stone v. Boston Steel & Iron Company*, 14 Allen (96 Mass.) 230 (1867)**

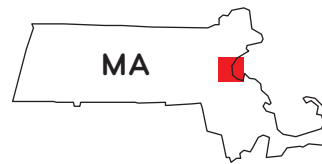


Figure 8-135. Vicinity map.

A plan for division of tidal flats prepared by a surveyor following an order by a court showed the disputed area at the deepest part of a cove in Massachusetts. A 60 chain long baseline was drawn

across the cove from headland to headland [at high water mark]. The greatest distance at right angles from the high water mark to such base line was about 500 feet and the low water mark was almost entirely outside of and nowhere more than a few feet within the base line as shown in figure 8-136.

Figure 8-137 shows lots in litigation and the contentions by the parties of how the side lines should be run. The first deed was to N. Tufts described as sketched including "ninety four feet breadth of flats adjoining the above described lot to low water mark, with all the privileges and appurtenances thereunto belonging."

The second deed was to D. Tufts and was similarly worded including the shore space wording. Likewise, the third deed was to Little, which was worded in a similar manner.

Successor in interest to the Tufts and Little deeds believed that their flats were run on an extension of their side lines.

Another successor in interest to the Harris and Hall lots in figure 8-137 later sold to Stone, called the demandant in the case. The demandant's deed read, in part, "northeasterly on Medford River" and "with all the flats

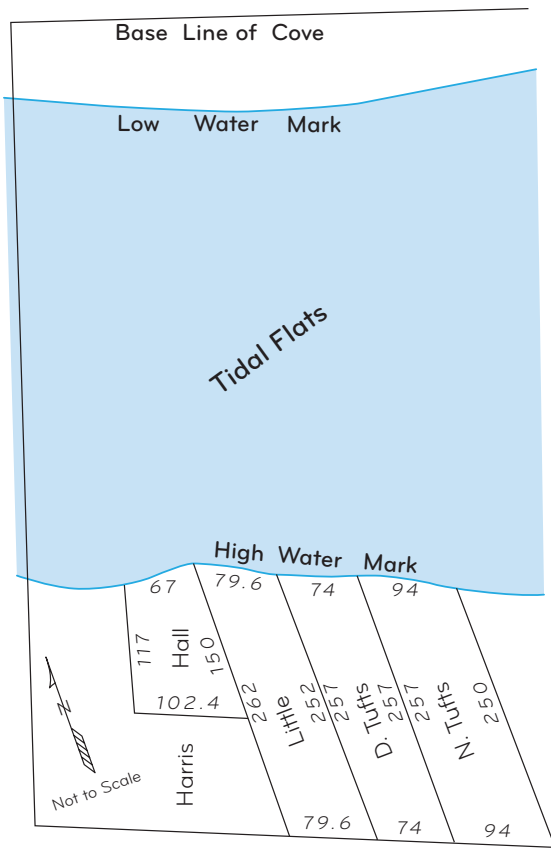


Figure 8-136. Tidewater cove.

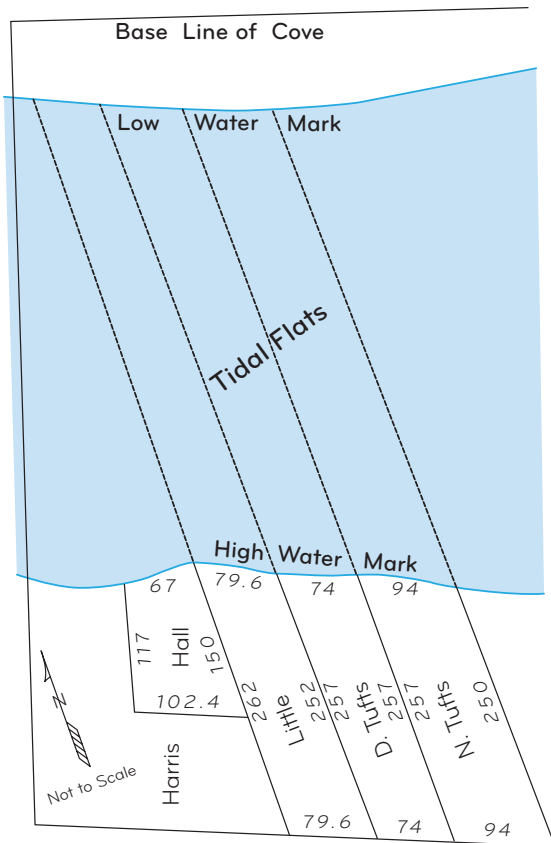


Figure 8-137. Division of tidal flats by property lines extended.

belonging to the same and all privileges and appurtenances thereto belonging, be the same more or less.”

Stone claimed his side lines should extend at right angles to the base line.

The court stated the general rule intended but not expressly stated in the Colonial Ordinance was, “that in all cases, when practicable, every proprietor is entitled to the flat in front of his upland of the same width at low water mark as they are at high water mark.”

Also, in *Porter v. Sullivan*, 7 Gray (73 Mass.) 441 (1856), each proprietor, “must be in front of the land, that is, directly to the sea from which the tide flows, by lines as nearly as practicable perpendicular to the line of shore or the line of ordinary high water mark.”

Figure 8-138 illustrates the Court’s decision, the side lines drawn at right angles with the base line of the cove, to low water mark. It may be seen that any owner along the high water mark line would be granted a share of the flats according to his frontage in the direction of the sea.

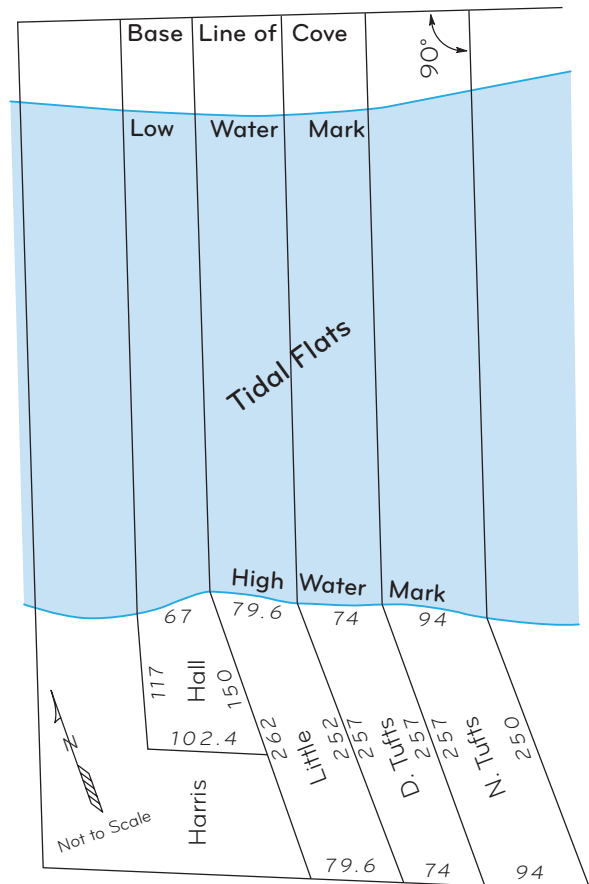


Figure 8-138. Tidewater cove showing the Court’s decision—division lines at right angles to baseline.

**Walker v. The Boston & Maine Railroad, 3 Cush. (57 Mass) 1 (1849)**

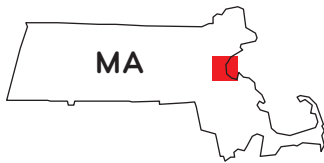


Figure 8-139. Vicinity map.

Walker owned a lot along the high water line of a large shore space in Charlestown, Massachusetts. Walker's surveyor prepared a plan for division of the flats in front of his property (figure 8-140). The plan included drawing a base line from a headland to headland as shown by the dashed line. The division lines of the claim were set as perpendiculars to the base line and they extended outward to a channel. Walker thus admitted that her claim could not extend beyond a channel that contained seawater at the lowest tides.

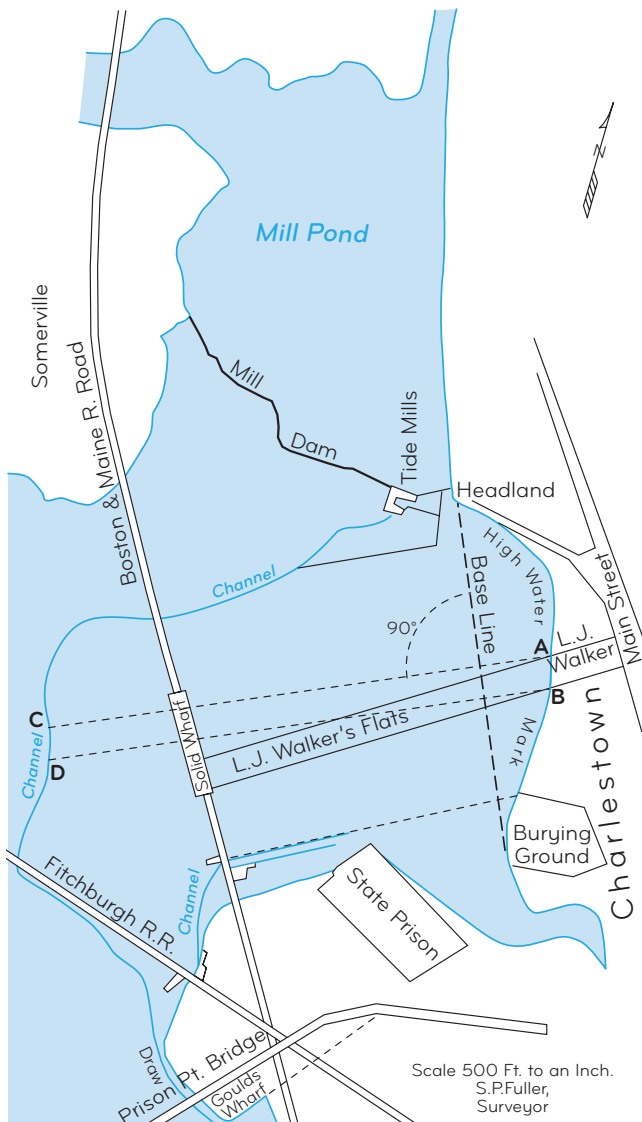


Figure 8-140. A plan for division of the flats.

The conflict arose because the railroad had taken land to construct their railroad that crossed the area of the flats claimed by Walker.

The area of flats included a dam that was operated as a tide powered mill. From the outfall of the mill the tidal channel ran westerly after crossing the railroad and thence curved back around to join with a second and smaller channel near the bottom of figure 8-140. The longer channel they defined as the terminus of the flats in that direction. The smaller channel began near the state prison running below the railroad and curving southerly to join the longer channel. The alignment of the smaller channel was extended to the upland and the Court defined it as the terminus of the flats in the direction of the State Prison, citing *Sparhawk v Bullard*, 1 Met. (42 Mass.) 95 (1840).

The Court found in favor of the railroad. It held that the railroad alignment was as short a distance across the flats as any place between the two creeks. It stated the rule thus:

To form the outer or low water line, draw a line across the narrowed space between the two creeks, as the mouth of the cove. If the low water line is shorter than the high water line, take the whole length of the upland, and ascertain each owner's proportion, and give him the same proportion on the low water line, and in the same order, and then let lines be drawn from each proprietor's lines, at high water, to his corresponding point in the low water line, and this will define the limits of the flats of each owner.

The Court ended the discussion stating that though the method chosen for division of flats may be liable to objections, "we know no mode of dividing these flats, which would be free from objection."

**Gray v. Deluce, 5 Cush. (59 Mass.) 9 (1849)**

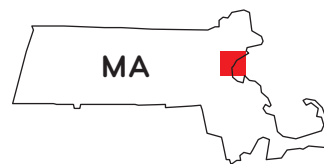


Figure 8-141. Vicinity map.

One-time tenants of the Deluce property in Boston, Massachusetts built a wharf in 1808 in trespass on part of the flats demanded by Gray. They extended the wharf in 1812 and again in 1826 and used it during those times. Presumably the extensions to the wharf were also in trespass (figure 8-142).

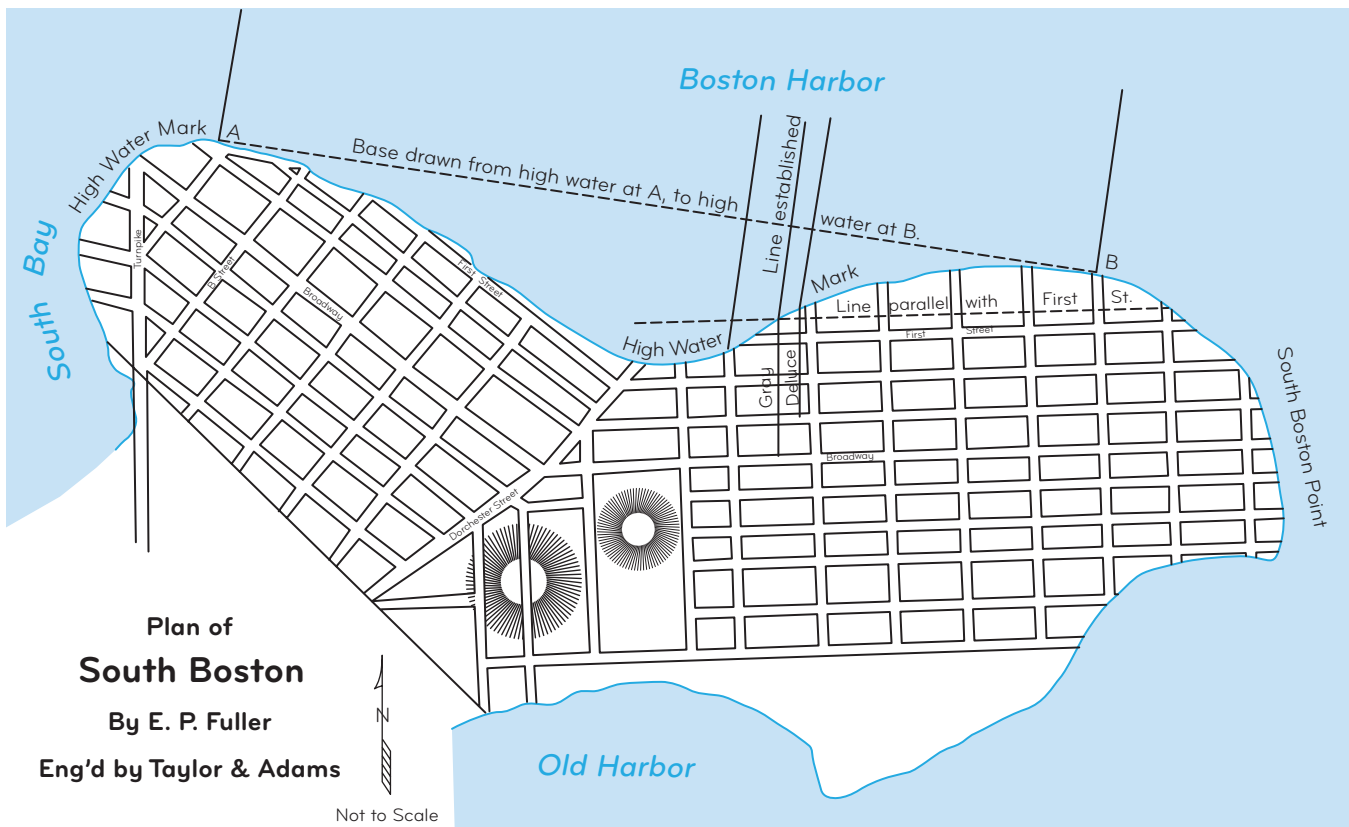


Figure 8-142. Boston Harbor.

The Court stated that the rule in Massachusetts followed the Colonial Ordinance of 1641 such that the proprietor of upland shall have ownership of the flats to the low water mark but no farther than 100 rods. Where the flats are located in front of coves, the Court found, the rule in Massachusetts is that, if practical, the upland owner shall get the flats in front of him in width equal to his width at high water mark.

The case as reported does not describe how the trespass was decided but only addressed the division of the flats. The division was made by drawing lines perpendicular to the base line of the cove.

**Adams v. Boston Wharf Company**, 10 Gray (76 Mass.) 521 (1858)

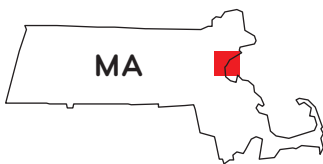


Figure 8-143. Vicinity map.

This was a case in Boston, Massachusetts where the rule that the division line of flats is to be perpendicular to the base line of the cove was not upheld.

This was because of the long continued acquiescence by the parties for at least 35 years to a previous legal proceeding.

Adams contended that the flats in dispute were appurtenant to a tract of upland formerly owned in common by Perkins, Mason, Gardner and others. The flats in dispute were part of a plan made in 1803-04 for a large Addition to the town of Boston. On that overall plan, the division of the flat was made parallel to A Street, to the west, and B Street and thus perpendicular to Second Street (figure 8-144).

Adams at time of trial presented a plan that showed the base line of the cove and his claim that the correct division lines were perpendicular to the base line of the cove as approved in *Gray v. Deluce*, 5 Cush. (59 Mass.) 9 (1849) (figure 8-144). The reason Adams made the request is not given in the text of the trial.

The Court found that Adams was correct in that the rule for division of flats was to draw straight lines from the two shore corners of the upland, perpendicularly to a base line extended across the cove. Also, the Court admitted that by that rule the flats in dispute would belong to the Adams' upland.

One of the original requirements of the 1803-04 Addition was that the entire estate, flats as well as uplands, be divided. It seems that the owners of the land in the proposed Addition and the officers of the



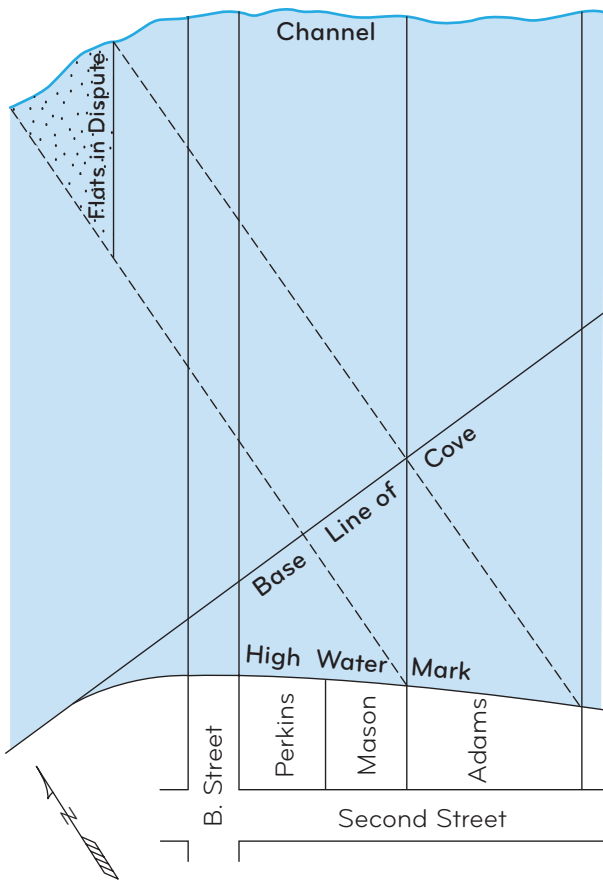


Figure 8-144. Two approaches to division of tidewater flats.

town had a mutual agreement that the lines of the flats would not be deflected to the base line because those lines could not cross B Street, [side lines extended]. All the owners of the uplands involved in 1803-04 except one, Harriet Denny, had agreed that the lines of the flats lines could not cross B Street.

By 1845 Mrs. Denny and her successors had not protested the division approved in 1803-04. The Court found that all the interested parties for a period of at least 35 years had acquiesced in the former division and therefore could not claim across B Street to the flats in dispute.

***Wonson v. Wonson*, 14 Allen (96 Mass.) 71 (1867)**

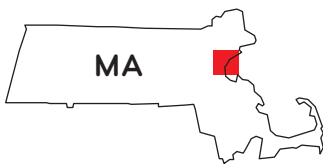


Figure 8-145. Vicinity map.

William C. Wonson, Samuel Wonson, James Davis, and William Parsons each owned upland around Coos' Cove, a deep salt water cove between two head-

lands in Massachusetts. Each of the parties had wharves that they used for shipping by water. William C. Wonson

and Davis wanted to settle the boundaries of the flats between themselves but unless all the owners involved in the settlement were included, no real settlement could be reached.

The Court appointed three commissioners to settle the matter. The commissioners used a plan prepared by one A. Boschke, civil engineer, which was made part of the transcript. The outline of the wharf construction by each owner is shown on the plan as well as a base line that was drawn from headland to headland connecting the line of high water at ordinary high tides. The commissioners all agreed that the cove was so deep that a division by line perpendicular to the base line was impractical. The main problem was that the tide never ebbed beyond the base line.

In order to arrive at an equitable answer the commissioners created a number of alternative methods of division of the flats. All of the methods used the ratio of each owner's frontage at the line of high water at ordinary high tides to the total length at the line of high water at ordinary high tides.

Method 1, the mode preferred by the commissioners, created division lines by the proportionate ownerships dividing lines equidistant from the line of high water at ordinary high tide to the line of extreme low water in the ratio as the length of the lines of upland owned by the party, giving to each shore owner his proportionate share of the area of each belt of flats within the cove (figure 8-146).

Method 2 created division lines by the proportionate ownerships dividing the baseline (figure 8-147).

Method 3 created division lines by the proportionate ownerships dividing the line of extreme low water using straight lines (figure 8-148).

Method 4 created division lines by the proportionate ownerships dividing the line of extreme low water to the extent that it fell within the base line (figure 8-149).

The Court held that the Commissioners had no authority to make a division according to the location of wharves that had been in place more than 20 years. Method 1 was discarded because the dividing lines were not straight, but curved and serpentine, making each lot of a shape peculiarly inconvenient for the building and use of wharves and bears injustice upon Davis, giving him a disproportionately narrow strip of flats, especially at low water mark.

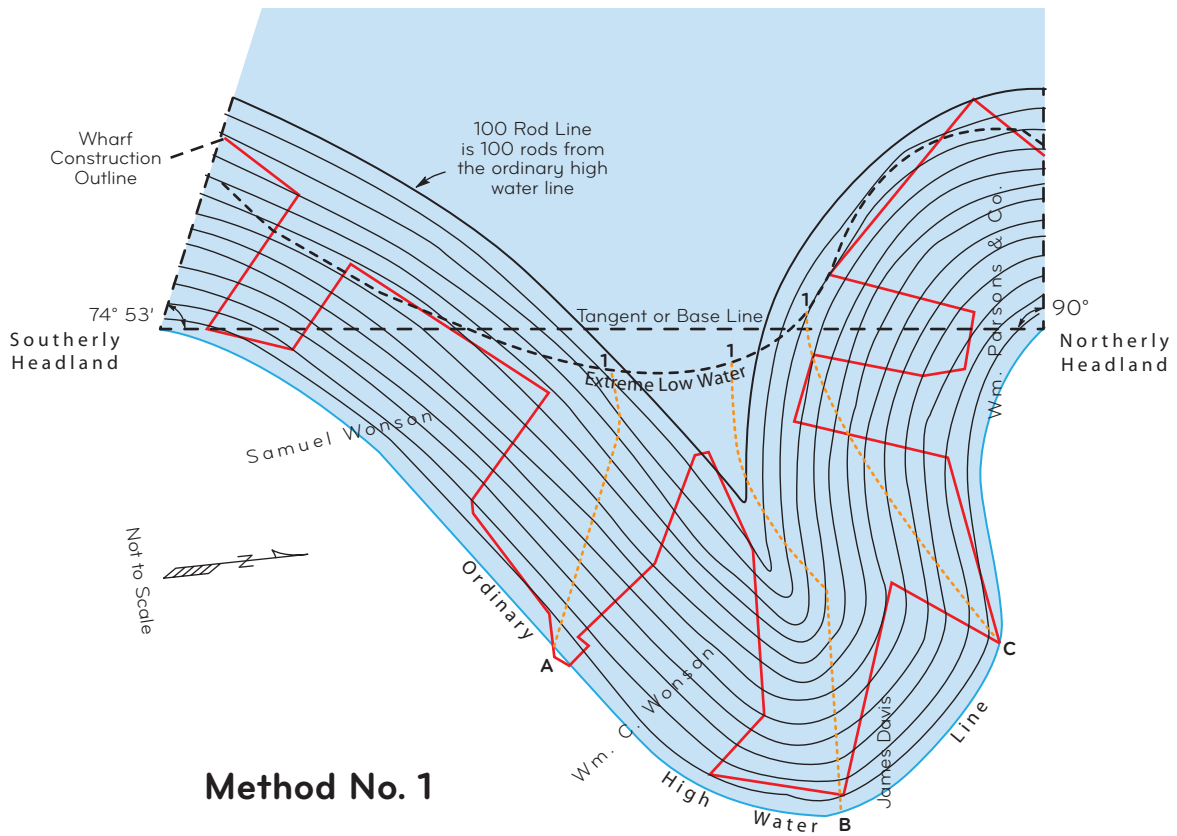


Figure 8-146. Method 1 for the division of tidewater flats.

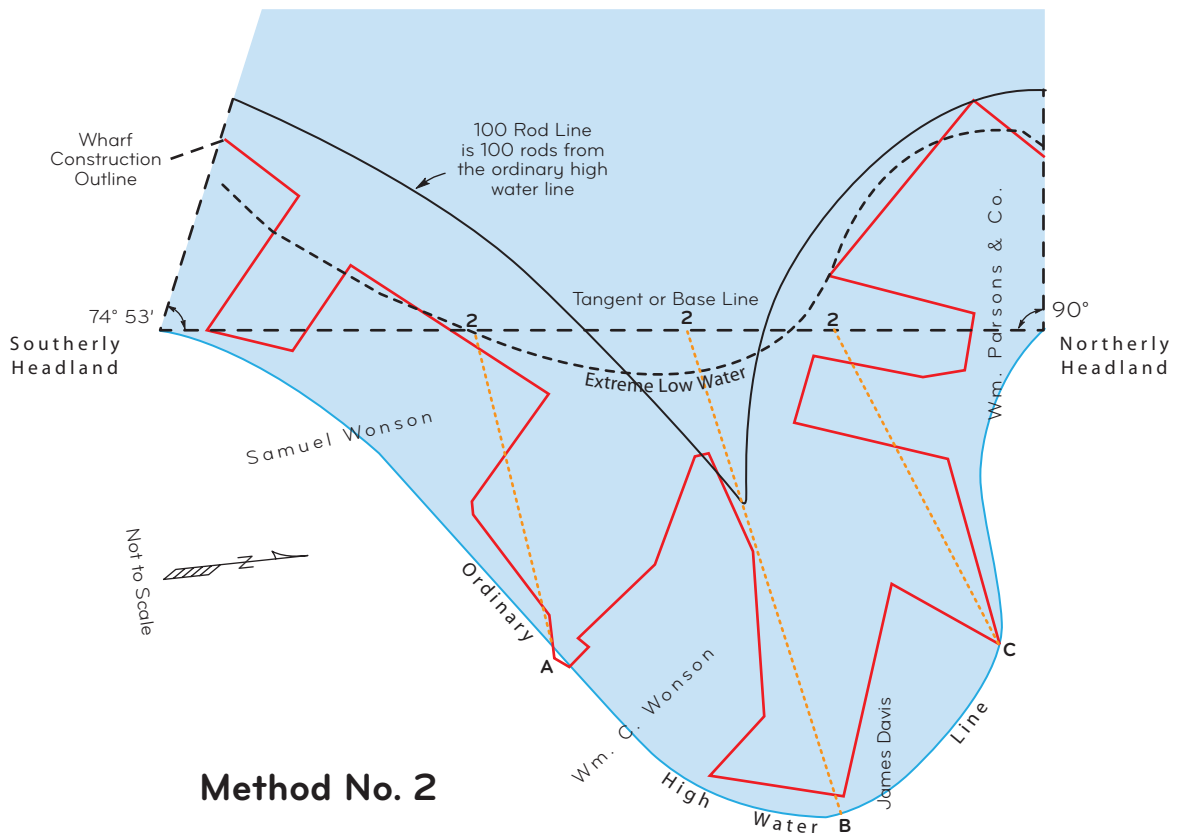
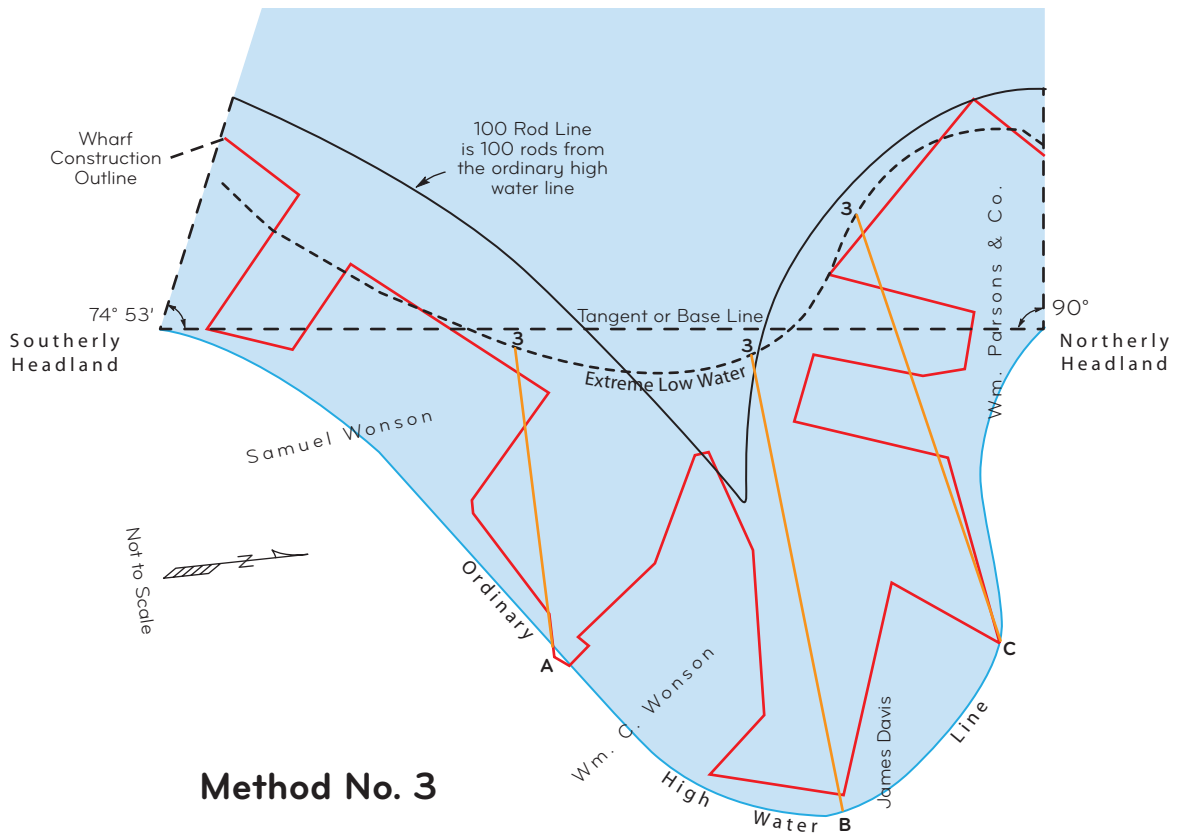
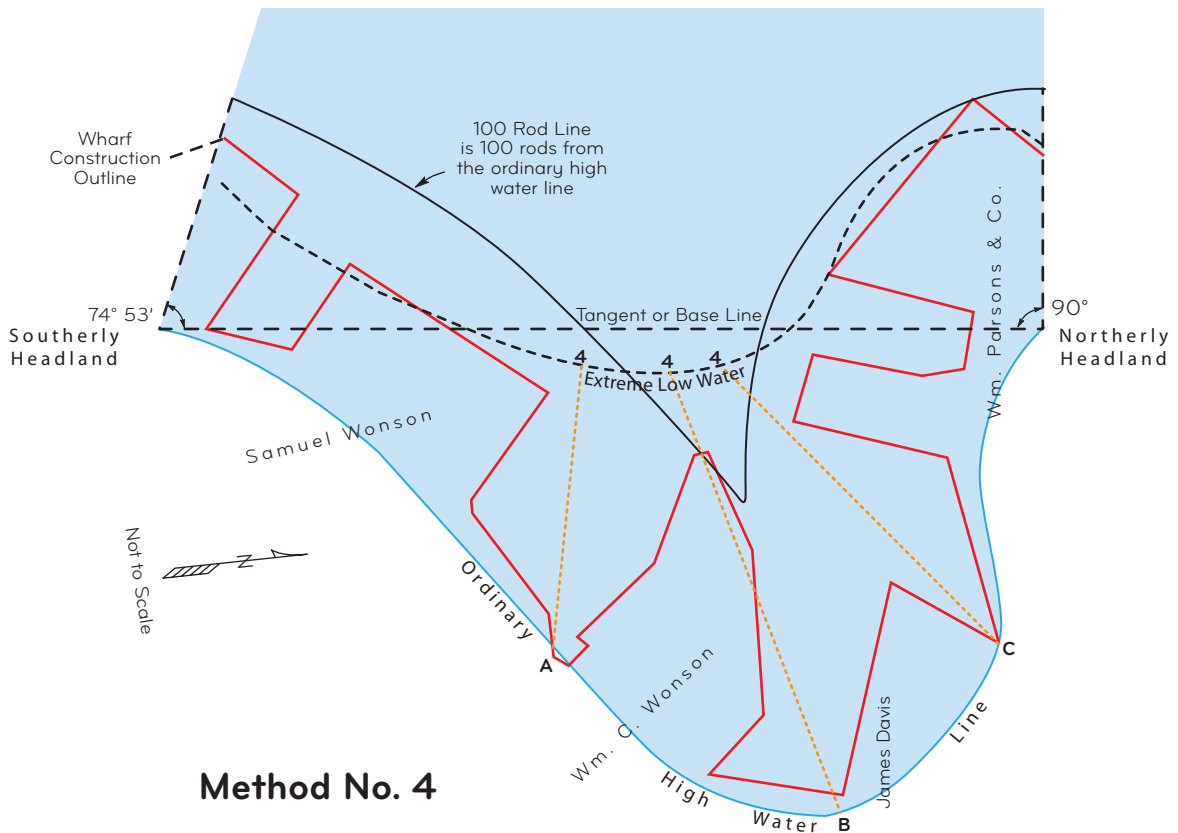


Figure 8-147. Method 2 for the division of tidewater flats.



**Method No. 3**

Figure 8-148. Method 3, the Court approved division of tidewater flats.



**Method No. 4**

Figure 8-149. Method 4 for the division of tidewater flats.

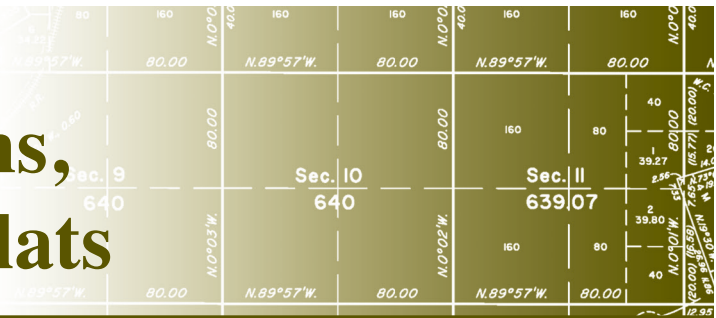
Method 2 established points of division beyond the line of extreme low water and thus did not conform to the Ordinance of 1647 and was rejected.

Method 4 would not allow a wharf to be built to the line of extreme low water because of the restriction so that method was rejected.

Method 3, which divided the flats to the proportionate ownerships applied to the line of extreme low water, was the approved method.

## Chapter IX

# Special Instructions, Field Notes, and Plats



## Special Instructions

**9-1.** The detailed specifications for each survey are set out by the officer in administrative charge of the work in a written statement entitled “Special Instructions.” The special instructions are an essential part of the permanent record of the survey, both as historical information and because they show that the survey was properly authorized and conducted. The immediate purpose is to outline the extent of the field work and the method and order of procedure as well as to guide the assigned surveyor. Coupled with the Manual, the special instructions contain the technical direction and information necessary for executing the survey. Emphasis is given to any procedure unusual in application, but no lengthy discussion is required of procedures that are adequately covered in the Manual. The special instructions are written in the third person.

**9-2.** Shown below is the arrangement of subject matter in the special instructions. Italicized portions denote standard phraseology:

- (1) Title: *Special Instructions*  
*Group No. \_\_\_\_*, (State)

(Nature of survey, and location by township, range, and meridian)

- (2) Preliminary statement:

*In the execution of the surveys included under Group No. \_\_\_\_, (State), the chief of field party is authorized and directed to make the described examination, retracements, reestablishment of points of control, surveys, and resurveys set out in these instructions. The surveyor will be guided by the Manual of Surveying Instructions (edition), hereinafter referred to as the Manual, the provisions of the following special instructions, and such supplemental special instructions as may be issued during the progress of the work.*

- (3) *Authority*

A brief statement must include the nature of the survey and the Federal agency or party requesting the survey. Cite departmental or BLM instructions or authorization, if applicable, and authority to execute the survey or any special act of Congress relating to the survey.

- (4) *Appropriation*

*The costs of the field and office work incurred in the execution of the survey, within approved official regulation, are payable from the appropriation:* Give the title of the applicable appropriation, fund, or deposit, and cite the act of Congress under which a deposit has been received.

- (5) *Limit and Character of Work*

Describe the lines to be surveyed by township, range, and meridian, with designation by section where only parts of townships are authorized. If the work involves other than original surveys, indicate the character of the fragmentary survey, the type of resurvey, or the nature of the field or office examination or investigation. Legal or technical questions related to the work may be pointed out here or in the part of the instructions dealing with methods, whichever is most appropriate. Similarly treated would be known facts concerning private rights that may be affected and directions for protecting those rights.

If the work involves meanders of water bodies, and the meandering of all islands is not authorized in the township or section where only parts of townships are authorized, indicate that title determination and survey of the remaining islands may be accomplished under future special instructions.



*(6) History of Surveys*

Each new survey, retracement, or resurvey is predicated on the survey(s) accepted previously. The pertinent existing surveys are reviewed in the special instructions with an explanation of known or presumed complications.

*(7) Method and Order of Procedure*

If the projected work is an extension of original surveys, it will be taken up in the following order in the special instructions:

- (a) Standard parallels and guide meridians
- (b) Township exteriors
- (c) Subdivisions, including meander lines
- (d) Subdivision of sections if included

The special instructions for each township should be completed separately. If complications are anticipated, the surveyor will be informed what to expect and what methods to apply. References to Manual rules are made by chapter and section numbers, but the surveyor is expected to understand regular practices and to be familiar with the Manual as a reference guide in unusual cases. The burden of this should not be transferred to the special instructions.

If the work involves other than original surveys, detailed specifications are stated for required examinations, investigations, fragmentary surveys, resurveys, topographic surveys, or special monumentation. Chapter X discusses how the usual types of special surveys are treated.

Where precautions need to be taken for the preservation of esthetic values in the environment, such as the elimination of blazing on the lines or the limitation of vehicular use, the special instructions should so state. Additionally, the surveyor will be directed to exercise care in situations that arise in the field that were not covered by the special instructions.

*(8) Diagrams and Supplemental Data*

A diagram should be furnished as a part of the special instructions. The assigned work

is usually shown by dashed lines and the adjoining previous surveys by solid lines. The diagram should indicate the directions and lengths of lines of the established surveys within 2 miles of the new assignment. Outlying areas protracted as though surveyed on the previous plats should always be shown. Digital geographic information data may be furnished as a part of the special instructions.

A notation may be made in the special instructions that copies of the plats and field notes of previous surveys pertinent to the assigned work will be furnished to the surveyor prior to commencement of the field work.

Known claims, improvements, or monuments of other official and local surveys will be noted in the special instructions.

When pertinent to the survey, the special instructions are supplemented by a status report, usually in the form of a diagram, showing disposals, withdrawals, and administrative units in the area to be surveyed or resurveyed. Streams upon which withdrawals for power sites or other purposes have been or may be made, and streams, ridges, or divides that constitute the boundaries of reserves, should be specified.

As a precaution to insure that the necessary accuracy be secured with reference to the cadastral geographic information system, there may also be supplied with the special instructions a list showing the geographical and administrative features in the area to be surveyed or resurveyed. A list of available topographic maps, aerial photographs, and other data showing important map features may be supplied with the special instructions. Any required additional mapping to be done in the field should be indicated.

*(9) Field Notes, Plats, and Reports*

The special instructions should include directions for the preparation of the field notes and point out the parts of the returns that will require special attention in the field. If a preliminary report or diagram is to be submitted during the progress of the field work, the special instructions will so state. Special

lottings or other unusual matters that are to be considered when the final returns are prepared should be specified.

Direction will be given to return for official use the special instructions and other papers that belong with the official record, data added in the field, and field computation sheets.

#### (10) *Modification of Special Instructions*

The special instructions should direct the chief of field party to report promptly conditions that call for additional or modified special instructions together with a recommended procedure.

**9-3.** The special instructions are ordinarily prepared and signed by the technical officer in direct administrative charge of the particular surveying program. Approval of the special instructions is by the Chief Cadastral Surveyor in administrative charge of the area where the survey is made, or as delegated by current regulations. The date of the special instructions and date of approval are always shown.

**9-4.** Assignment instructions are the written instructions to the Federal authority surveyor authorizing the surveyor to execute a specific part, or all, of a particular survey. Although a survey may be authorized by the special instructions, a surveyor may not perform any part of that survey without assignment instructions containing the specific assignment. Normally, approval of the assignment instructions is identical to approval of special instructions.

## Field Notes and Plat

**9-5.** Title 43 U.S.C. 751 (Act of May 18, 1796; 1 Stat. 464) required that detailed field notes and a plat be prepared from the surveyor's field tablets. However, the manner in which such field record data and field notes are recorded and maintained is within the discretion of the Secretary of the Interior and the Secretary's delegate, the Director of the Bureau of Land Management.

The authority of the Director of the BLM includes the authority to decide whether to place field notes on plats or in separate books. The mode by which approved field notes are permanently prepared and the medium employed for their preservation and availability for public use are not prescribed by any statute. These details have been left to the discretion of the Director, subject

only to the Act of May 18, 1796 and the general requirements of law governing the management of Federal agency records.

## Field Notes

### Purpose and Style

**9-6.** The field notes are the written record of the survey. This record identifies and describes the lines and corners of the survey and the procedures by which they were established or reestablished. The field notes describe the evidence found and the new evidence established. They provide the explanation and justification for the decisions made to locate the lines and corners. The new subdivisions to be platted (or replatted in the case of some resurveys) and the quantity of land in each unit are derived from the field notes. The laws governing surveys of the public lands have required the return of field notes from the beginning. Field notes are official after approval by the authorized official and official filing. The chosen manner of recordation shall be clear and consistent, making the field notes accessible to Federal personnel and the general public.

**9-7.** Approved field notes are a part of the permanent official records of the Department of the Interior and are competent evidence in courts with the force and effect of a deposition. They rank as the deposition of a surveyor, charged under oath with the duty of noting on the spot, and at the time he or she makes the survey, the quality of the land (*Mason v. Cromwell*, 26 Pub. Lands Dec. 369 (1898); *Kirby v. Lewis*, 39 F. 66 (C.C. Ark. 1889)).

**9-8.** The initial notes are gathered, utilizing various written and electronic forms, by the surveyor while in the field. The transcribed record that is derived from the field record data is termed the field returns. The field returns consist of the draft field notes and sketch plat which are transcribed from the field data and submitted to the appropriate official for review, approval, and filing. The final field notes prepared for filing are printed in regulation field note format or placed upon the survey plat.

It is desirable that the draft and final field notes conform to the general arrangement and phraseology set out in the Manual. A large part of the final field notes must be extended from an abbreviated field record. At the same time, much of the minute detail of the initial field record data may be summarized into a form of

record that refers directly to the completed survey. This distinction in the three stages of the record is carried through the text: (1) Initial field record data gathering, (2) draft (preliminary) field returns, and (3) final (official) survey record.

**9-9.** In the case of surveys such as the limited dependent resurvey or retracement of a section line, the survey of a connecting line, the survey of an island, Alaska U.S. surveys, or other surveys that require only a brief field note record, the field notes may be placed directly upon the plat.

**9-10.** All appropriate notes of the method, order of the survey procedures, and line and corner evidence are entered in the field data. The data should show the dates on which each part of the field work was done. The field data record must supply the information needed for a complete preparation of the final record. For efficient review, it is essential that all field tablets and field data records be properly indexed.

Because of the great variety of survey types, the surveyor must plan carefully how the data in the field record is to be arranged. The assigned surveyor is responsible for the accuracy and sufficiency of this record.

The work of transcribing the field record data usually receives the personal attention of the assigned surveyor, but it is important that the arrangement of the field record data and the use of abbreviations be such as to be readily understood by others who are familiar with the technical processes. Due regard will be given to the Manual requirements and form, though it is intended that set forms of expression be used flexibly and modified when necessary to conform to the survey procedure. The work of the reviewing officers is directed to the fundamental requirements of the Manual and the written special instructions. Comments *as to the form* of the transcribed field notes are based upon broad grounds, but it is necessary that the notes follow a standard form.

Random lines are shown in the field record data but are omitted from the transcribed field note record except where some special purpose is served by showing the detail of the method and order of the procedures. The specific random line, elements of triangulation figures, traverse, or offset lines are seldom noted in the field note record. It is usually sufficient to show only the true line data in the field notes when the field procedure results in ascertaining the course and length of the lines being established.

**9-11.** The township is considered as the unit in compiling the field notes. Normally the field notes of all classes of lines pertaining to a township when concurrently surveyed and not previously compiled are included in a single “set of field notes.” In the survey of a block of exterior lines only, all of the field notes may be placed in one set of field notes. If a block of townships is being surveyed concurrently, common boundaries are written in the notes of one township or the other, but not both. The sets of field notes are compiled in volumes for the permanent filing of the record as directed by the proper supervising officer.

**9-12.** The field notes, plat, and contract or group file are considered the primary record of any survey. Upon approval of the field notes, and acceptance and filing of the plat, the responsibility for the survey vests in the accepting authority. The survey is not official until it has been approved and accepted by the authorized official and officially filed in the proper Land Office. The lands are not considered surveyed or identified until the survey has been officially filed. It was held in *Cox v. Hart*, 260 U.S. 427 (1922), that:

A survey of public lands does not ascertain boundaries; it creates them. *Robinson v. Forrest*, 29 Cal. 317, 325; *Sawyer v. Gray*, 205 Fed. 160, 163. Hence the running of lines in the field and the laying out and platting of townships, sections and legal subdivisions are not alone sufficient to constitute a survey. Until all conditions as to filing in the proper land office and all requirements as to approval have been complied with, the lands are to be regarded as unsurveyed and not subject to disposal as surveyed lands. *United States v. Morrison*, 240 U.S. 192, 210; *United States v. Curtner*, 38 Fed. 1, 10.

**9-13.** After the final record has been prepared, approved, accepted, and officially filed, and the period for a timely protest and appeal has expired, the field tablets and related field data are disposed. The contract and group files are retained permanently.

### Field Notes Preparation and Inking the Field Notes

**9-14.** Two copies of the field notes are prepared. The medium used for the original and duplicate original field notes is to be of high quality, archival paper with permanent black ink. Generally they should be printed on 20-pound, 25 percent cotton rag bound paper in the 8.5- x 11-inch size. Field notes should be prepared with

two-sided content. A minimum of 1-inch margin must be maintained on the left side for binding. The print work should be sharp and clear, uniform in density of color, and with standardized lettering.

**9-15.** Another important consideration in the field notes print work is the size and density of information shown. Currently many public and other users of the records access them via microfilm, digital, scanning, and other imaging and reproduction technologies that may tend to lose small detail, and this should be considered in the process. Text fonts or symbols that are so small as to render them illegible after being photocopied, microfilmed, or scanned should not be used.

The arrangement of some of the more minute data on the specimen field notes illustrates the minimum to which the work may be condensed safely. Attention is directed to the space allowed between the lettering and the adjacent lines. Proportionately more space should be allowed on drawings in the field notes where a reduction of scale is to be made on reproduction. The same safeguards should be applied in spacing the adjoining letters.

### Cover Page—Titles

**9-16.** Each set of field notes is preceded by a cover page included in a regulation cover, with appropriate title setting out general information as follows:

- (1) The description of the lines recorded in that set;
- (2) The principal meridian to which the survey refers;
- (3) The State in which the survey is located;
- (4) The name or names of the surveyors by whom the work was executed;
- (5) The date of the special instructions, with survey number or serial group number, and date of approval;
- (6) The date of the assignment instruction; and,
- (7) The dates of the beginning and completion of the work included in that set.

Following are examples of titles:

**FIELD NOTES**  
OF THE SURVEY OF THE

WEST AND NORTH BOUNDARIES  
AND SUBDIVISIONAL AND  
MEANDER LINES OF TOWNSHIP 41 NORTH,  
RANGE 13 WEST, OF THE  
SIXTH PRINCIPAL MERIDIAN,  
IN THE STATE OF WYOMING,

**EXECUTED BY**

Wm. C. Jones, Cadastral Surveyor  
(or)  
John B. Smith and Fred A. Brown,  
Cadastral Surveyors  
(All)

Under special instructions dated June 30, 2009, which provided for the surveys included under Group Number 205, approved July 9, 2009; and assignment instructions dated July 15, 2009.

Survey commenced July 26, 2009.  
Survey completed October 8, 2009.

**9-17.** The descriptive portion of the title is appropriately modified in special cases as in the following examples:

**FIELD NOTES**

OF THE  
SURVEY OF A PORTION OF THE  
SUBDIVISIONAL LINES  
COMPLETING (or CONTINUING)  
THE SUBDIVISION OF  
TOWNSHIP 39 SOUTH, RANGE 18 EAST,

(or)

**FIELD NOTES**

OF THE  
SURVEY OF FIDDLERS ISLAND IN VENICE BAY,  
IN SECTION 1, TOWNSHIP 39 SOUTH,  
RANGE 18 EAST,

(or)

**FIELD NOTES**

OF THE  
DEPENDENT RESURVEY OF THE  
EXTERIOR AND SUBDIVISIONAL LINES OF  
TOWNSHIP 18 SOUTH, RANGE 59 WEST,

(or)

**FIELD NOTES**

OF THE  
DEPENDENT RESURVEY OF THE



ELEVENTH STANDARD PARALLEL NORTH,  
ON THE SOUTH BOUNDARY OF  
TOWNSHIP 45 NORTH, THROUGH  
RANGE 79 WEST, THE EAST BOUNDARY OF  
TOWNSHIP 45 NORTH, RANGE 80 WEST,  
AND SOUTH BOUNDARY OF  
TOWNSHIP 46 NORTH, RANGE 79 WEST,  
AND THE  
INDEPENDENT RESURVEY OF THE  
EAST BOUNDARY AND SUBDIVISIONAL LINES  
OF TOWNSHIP 45 NORTH, RANGE 79 WEST,  
AND TRACT SURVEYS OF PRIVATE CLAIMS  
(or)

**FIELD NOTES**

OF THE  
DEPENDENT RESURVEY OF THE BOUNDARIES  
OF THE  
ANASTASIA ISLAND LIGHTHOUSE AND  
MILITARY RESERVATIONS,  
IN SECTIONS 21, 22, 27, AND 28,  
TOWNSHIP 7 SOUTH, RANGE 30 EAST,  
(or)

**FIELD NOTES**

OF THE  
DEPENDENT RESURVEY OF  
PORTIONS OF THE NORTH BOUNDARY OF  
U.S. SURVEY NO. 1456,  
THE NORTH AND SOUTH CENTER LINE  
OF THE SOUTHWEST ONE QUARTER  
OF SECTION 9, AND A PORTION OF THE  
SUBDIVISIONAL LINES  
SITUATED AT THE ALASKA RAILROAD  
TERMINAL RESERVE,  
IN THE MUNICIPALITY OF ANCHORAGE,  
TOWNSHIP 13 NORTH, RANGE 3 WEST,  
(or)

**FIELD NOTES**

OF U.S. SURVEY NO. 9901  
AT MILE 320, ALASKA HIGHWAY  
AND THE ESTABLISHMENT OF CONTROL  
POINT NO. 9901 AT  
GEOGRAPHIC POSITION (NAD 83):  
LATITUDE 53°22'17.63" N.  
LONGITUDE 146°58'43.00" W.  
(or)

**FIELD NOTES**

OF THE  
DEPENDENT RESURVEY AND EXTENSION  
SURVEY, SUBDIVIDING LAND BORDERING

FERRY LAKE AND JAMES BAYOU,  
IN SECTIONS 9, 10, 15, AND 16,  
TOWNSHIP 20 NORTH, RANGE 16 WEST,  
(or)

**FIELD NOTES**

OF THE  
DEPENDENT RESURVEY OF THE SECTION  
BOUNDARIES, THE SUBDIVISION OF THE  
SECTIONS, AND THE ESTABLISHMENT OF  
CORNERS OF INDIAN ALLOTMENTS,  
IN SECTIONS 9, 10, AND 15,  
TOWNSHIP 143 NORTH, RANGE 30 WEST  
(or)

**FIELD NOTES**

OF THE  
DEPENDENT RESURVEY OF THE SECTION  
BOUNDARIES, THE SUBDIVISION OF THE  
SECTIONS, AND THE  
ESTABLISHMENT OF THE BOUNDARY, BLOCK  
AND LOT CORNERS,  
AND STREET CENTER LINES OF THE  
TOWNSITE OF LAC DU FLAMBEAU,  
AND THE SPECIAL SURVEY OF  
U.S. HIGHWAY NO. 93,  
IN SECTIONS 5 AND 8,  
TOWNSHIP 40 NORTH, RANGE 5 EAST,  
(or)

**FIELD NOTES**

OF THE  
DEPENDENT RESURVEY OF A PORTION OF  
THE SOUTH BOUNDARY, A PORTION OF THE  
SECTIONAL GUIDE MERIDIAN,  
AND A PORTION OF THE  
SUBDIVISIONAL LINES  
AND THE  
SURVEY OF TRACTS 37, 38, 39, AND 40,  
AND THE SUBDIVISION OF SECTION 26,  
ALL SITUATED IN THE ALASKA RAILROAD  
POWDER RESERVE,  
TOWNSHIP 15 NORTH, RANGE 2 WEST,  
(or)

**FIELD NOTES**

OF THE  
DEPENDENT RESURVEY OF THE  
SECTION BOUNDARIES  
AND THE  
MINERAL SEGREGATION SURVEY OF A  
PARCEL INCLUDED WITHIN THE  
WHITMORE QUARTZ AND THE MONDAY



QUARTZ MINING CLAIMS IN SECTION 22,  
TOWNSHIP 7 NORTH, RANGE 12 EAST,

(or)

**FIELD NOTES**

OF A TRAVERSE OF THE WORKINGS  
IN THE BADGER COAL MINE  
AND THE DEPENDENT RESURVEY AND  
SUBDIVISION OF SECTION 15,  
TOWNSHIP 36 NORTH, RANGE 75 WEST,

**Index**

**9-18.** Each set of field notes has a small-scale index diagram of the lines included. It is often necessary, however, to construct an additional special diagram to suit the work. For this a sheet of regulation field-note paper, or a sheet of the same size, is employed, and a scale adopted that is suited to the available space. It is usually preferable to orient the diagram with north to the top of the page, though sometimes the outline of the work is such that it is better to orient the diagram with north to the left-hand or binding edge. The diagram should show all of the lines surveyed with the page number on which the record of each begins or where the corner

description can be found. Meanders and other irregular lines should be drawn and indexed. However, if an area becomes complicated or congested, these lines may be tabulated at the bottom of the page or on an additional sheet. The added index sheet is inserted in the notes on the inside of the front cover, to appear on the right-hand side, without page number. Field notes will not be written on the index sheet.

**Page Headings and Subheadings**

**9-19.** Each page of the field notes is given a heading. The heading is a short summary of the title of the field notes to be continued on that page. New headings are employed within the body of the field notes where changes are made to a new division of the survey; this will become the heading of the pages that follow. The heading should include the township, range, principal meridian, and State. Examples may be found in the specimen field notes in the appendix.

New headings inserted in the body of the field notes of a resurvey are accompanied by subheadings that relate the resurvey to the earlier work (specimen resurvey field notes, appendix II). Subheading examples are shown below:

---

Dependent Resurvey of the West Boundary of  
T. 2 N., R. 18 W., Principal Meridian, Montana

---

(Restoring the 1882 survey by James M. Harvey)

---

(or)

---

Dependent Resurvey of the Eleventh Standard Parallel North,  
South Boundary of T. 45 N., R. 79 W., Sixth Principal Meridian, Wyoming

---

(Reestablishment of the survey executed by John B. Smith, Deputy Surveyor, in 1872)

---

(or)

---

Remonumentation of Certain Corner Points,  
T. 48 N., R. 3 E., Fifth Principal Meridian, Missouri

---

(Remonumenting a corner established by Laban H. Wheeler, U.S. Deputy Surveyor, in 1881)

---

(or)

---

Tract Surveys of Private Claims in  
T. 45 N., R. 79 W., Sixth Principal Meridian, Wyoming

---

(As originally located in accordance with the survey executed by  
John B. Smith, Deputy Surveyor, in 1872)

---

(or)

---

Independent Resurvey of the Subdivisional Lines of  
T. 45 N., R. 79 W., Sixth Principal Meridian, Wyoming

---

(Superseding the 1872 survey by John B. Smith)

---

(or)

---

Corrective Dependent Resurvey of a Portion of the North Boundary,  
T. 22 S., R. 1 W., Willamette Meridian, Oregon

---

(Restoring the survey by Nathaniel Martin in 1873, and correcting the dependent resurvey  
by Otto Draper, in 1933-35)

---

## Abbreviations

**9-20.** The following abbreviations in table 9-1, especially suited to field notes of surveys, are permitted in the final transcript record, and are used when repetitions in the form of the record and the expressions used are such as to make the abbreviations readily understood. These abbreviations are in addition to those shown in chapter II for analytical notation of observations, and those shown in chapter IV for marks upon monuments. Some of these abbreviations, as appropriate, are employed upon the township plat. All abbreviations should be given capital or lower-case letters the same as would be proper if the spelling were to be completed. Not all abbreviations used in the past by the GLO/BLM are listed. Previous editions of the Manual should be consulted for historical abbreviations.

## The Detailed Field Note Record

**9-21.** The introductory statement includes:

- (1) The surveys encompassed in that set of field notes.
- (2) The history of pertinent official surveys. The history of pertinent local surveys to the survey may be included.
- (3) The description of unusual survey situations and special methods used.
- (4) A statement that the survey was executed in accordance with specifications set forth in the Manual of Surveying Instructions (edition) and the special instructions.

(5) How the directions of lines were determined and that they refer to the true meridian. How the distances were determined.

(6) In the case of a dependent resurvey, a statement to the effect that "Preliminary to the resurvey the lines of the official original survey(s) and resurvey(s) were retraced and search was made for all corners, lines, other calls of the record, and, where available, collateral evidence of local surveys and corners. Identified corners were remonumented in their original positions; lost corners were restored and monumented at proportionate positions based on the official record. The retracement data were thoroughly verified and only the true line field notes are given herein."

(7) Descriptions of items that are repetitive in the body of the field notes are listed to provide conciseness to the field note record. These items are defined by notations, unless otherwise noted in the body of the field notes.

(8) The geographic position of two monumented corners of the survey, including the southeast township corner if practicable, the datum, and how the positions were determined.

(9) The observed magnetic declination, if any.

**9-22.** Each set of field notes needs to be organized by order of importance of the surveyed lines. The general format or order of writing field notes is as follows:

- (1) State Boundaries

Table 9-1. Abbreviations.

A	acres
alt.	altitude
a.m.	forenoon
Am.	amended
app. noon	apparent noon
app. t.	apparent time
asc.	ascend
BM	bench mark
bet.	between
bdy., bdrs.	boundary, boundaries
BLM	Bureau of Land Management
ch., chs.	chain, chains
cor., cors.	corner, corners
corr.	correction
decl.	declination
dep.	departure
desc.	descend
diam.	diameter
dir.	direct
dist.	distance, or distant
E.	east
e.e.	eastern elongation
elev.	elevation
ft.	foot, feet
frac.	fractional
GLO	General Land Office
Gr.	Greenwich
GM	guide meridian
hor.	horizontal
h.	hour, hours
h.a.	hour angle
HES	homestead entry survey
in., ins.	inch, inches
lat.	latitude
lk., lks.	link, links
l.m. noon	local mean noon
l.m.t.	local mean time
log.	logarithmic function
long.	longitude
l.c.	lower culmination

m.	minute, minutes, (time)
meas.	measurement
mer.	meridian
Mi. Cor.	mile corner
mkd.	marked
M.S.	mineral survey
N.	north
NE	northeast
NW	northwest
No.	number
obs.	observe
obsn.	observation
orig.	original
PLSS	public land survey system
p.m.	afternoon
pt.	point
Prin. Mer.	principal meridian
R., Rs.	range, ranges
red.	reduction
rev.	reverse
s.	second, seconds, (time)
sec., secs.	section, sections
S.	south
SE	southeast
SW	southwest
sq.	square
Stan. Par.	standard parallel
sta.	station
subd.	subdivisional
temp.	temporary
t.	time
T., Tp., Tps.	township, townships
u.c.	upper culmination
USLM	United States Location Monument
USMM	United States Mineral Monument
U.S.S.	United States Survey
vert.	vertical
W.	west
w.e.	western elongation
x	separating dimension values

(2) Senior Grant and Reservation Boundaries

(3) Principal Meridians

(4) Base Lines

(5) Standard Parallels

(6) Guide Meridians

(7) Township Boundaries

- (a) South Boundary
  - (b) East Boundary
  - (c) West Boundary
  - (d) North Boundary
- (8) Subdivisional Lines
- (9) (Sectional and Governing Lines prior to remaining Section Lines, Original and Completion Surveys only)
- (10) Subdivision of Sections
- (a) N-S Center Line
  - (b) E-W Center Line
  - (c) In cases of the subdivision of the quarter sections or smaller parcels, the same pattern will be used, starting with the NE $\frac{1}{4}$  and proceeding clockwise around the section. All lines of the quarter section will be written before proceeding to the next quarter section.
- (11) Meander Lines
- (12) Other Auxiliary Survey Lines

Usually corrective resurveys are written first, followed by dependent resurveys and new surveys. New surveys will include original survey, independent resurvey, subdivision of sections, and the survey of tracts or other nonrectangular parcels. Any line to be intersected by another line, or connected to by another line, should be written and appear first. Deviations from the order of writing field notes are allowable and encouraged to satisfy requestor requirements.

**9-23.** A full description of all monuments to be recovered is furnished with the special instructions. Such monuments shall be completely described in the new record. However, it is not required that the markings on the brass cap of a properly marked regulation monument be repeated. A year date is not added, unless needed for identification purposes. If the year date is added, that information will be placed in the field notes showing a complete corner diagram. The description of an identified corner should follow the order given in section 5-46. Examples of descriptions are shown in the specimen field notes.

**9-24.** When it is necessary to refer to a corner monument described in another set of field notes of concurrent

resurveys, a reference is given to the particular field notes in which the description of that monument will be found. For example: “the cor. of secs. 3, 4, 33, and 34, on the N. bdy. of the Tp., previously described in the field notes of the dependent resurvey of the S. bdy. of T. 24 S., R. 3 W., surveyed concurrently under this group.”

The complete description of a monument is entered once only in a set of field notes. In subsequent pages of notes the expression “heretofore described” may be employed when referring to a point already occupied in the new survey. For example: “the cor. of secs. 2, 3, 10, and 11, heretofore described” or “the standard cor. of secs. 33 and 34, heretofore described” or “the cor. of secs. 5, 6, 31, and 32, on the S. bdy. of the Tp., heretofore described.”

**9-25.** In the record of an independent resurvey the field notes of the tract survey of each valid claim are preceded by an abstract of entries. A brief statement then follows concerning the principal factors controlling the location of the particular tract. This must include whether or not the claimant was consulted or communicated with in identifying the boundaries of the claim. The statement must be clear as to whether the location of a claim, shown either as a tract segregation or as conforming to the lines of the independent resurvey, was controlled by collateral evidence, or by one or more identified corners of the original survey, nearby or remotely located, or by its relation to adjoining tracts. In case all of the tract segregations within a township can be covered by one general statement, the same should appear at the beginning of the field notes of the tract surveys. The field notes should be made to account for each tract shown upon the land status diagram.

**9-26.** Historical references to the records of earlier surveys that form a portion or portions of the plat outline should be incorporated in the introductory statement of the field notes. This includes surveys performed by the county surveyor and other local surveys found acceptable for the identification of tract boundaries, etc.

**9-27.** It is important to standardize the writing of the field notes or retracements and the subdivision of sections, and to simplify the record so far as possible. In the majority of cases this can be done by adherence to the following rules:

- (1) Complete descriptions are given in those cases where the retracement is not followed by dependent resurvey procedure or the subdivision of a section.

(2) No detailed description of the retracement is required in the field notes when the retracement is followed by a dependent resurvey. In that case the procedure is described in the introductory statement, and the corner monumentation and lines (corrected to true lines) are described in the field notes of the dependent resurvey. When the section lines are retraced as a preliminary to subdivision of a section, it is usually necessary to dependently resurvey them in order to establish sixteenth-section corners on the section lines. When applicable, a statement should be made that line trees were searched for but not found.

(3) The directions and lengths of the true lines; the descriptions with respect to the calls of the field notes of prior official survey(s) regarding natural objects, stream crossings, principal slopes, and other topographic calls; the descriptions of the physical, collateral, and record evidence or testimony concerning lost, recovered, or local corners and their accessories; and all new monumentation are given in the field notes. The need for completeness of descriptions of natural features called in prior surveys increases as the obliteration of evidence of the locus of the prior survey increases. For a line such as a highway curve, a minimum of three items of curve data is required; radius, arc distance, and long chord bearing and distance. The central angle may also be included.

(4) The descriptions of closing, intersection, and corners of minimum control of the exterior and subdivisional surveys placed and found on the standard parallels or township exteriors where the record calls for two sets of corners, and similarly within partially subdivided townships where there are offsets to be dealt with, should be given in the field notes of the lines of the exterior or subdivisional survey that is being retraced or dependently resurveyed.

(5) The descriptions of closing, intersection, and corners of minimum control of the exterior and subdivisional surveys placed but not found on the standard parallels or township exteriors where the record calls for two sets of corners, and similarly within partially subdivided townships where there are offsets to be dealt with, should be given in the field notes of intersecting or terminating lines of the exterior

or subdivisional survey that is being retraced or dependently resurveyed.

(6) When a closing, intersecting, or corner of minimum control is found that marks a line that is not being concurrently resurveyed, and is determined not to be on the exterior or subdivision survey that is being retraced or dependently resurveyed, a connecting course and distance and a complete description of the corner should be given in the field notes of the retracement or resurvey of the line closed upon. The corner point will be remonumented or perpetuated in such a manner that will secure its position for potential future utilization but not in a manner that could mislead innocent parties.

(7) When a closing, intersecting, or corner of minimum control is found and determined not to be on the exterior or subdivision survey that is being retraced or dependently resurveyed the new monument for a closing, intersecting, or corner of minimum control in those cases where required, will always be placed at the true point of intersection, after retracement of the intersecting line, and so stated clearly. An off-line monument will be remonumented, if necessary, marked AM, buried in place, connected by course and distance, and fully described in the field notes of the intersection line.

(8) Intermediate quarter-section corners between closing, intersecting, and corners of minimum control may be fully described in the field notes of the line being retraced or dependently resurveyed, or in the field notes of the closing section immediately following the description of the closing or intersecting line that completes the survey of the section. In the latter instance, a cross reference will be entered in the field notes of the retracement or resurvey of the line closed upon.

(9) The descriptions of the section, quarter-section, and sixteenth-section corners on the section boundary lines, as required for the subdivision of a section, will be given in the field notes of the section boundaries.

(10) Random or trial lines are treated in a prefacing statement concerning the type of work to be performed, but no field-note statement of the detail is necessary.



(11) The descriptions of the center quarter-section corner and the sixteenth-section corners within the section will be given in the field notes of the subdivision-of-section lines.

(12) Corner description only format of field notes may be authorized by special instructions when a determination has been made that the running line format is not necessary.

**9-28.** The character of the land, soil, and forest cover upon the lines surveyed will be summarized at the conclusion of the field notes of each mile, when required by special instructions. The record of the mile will be closed by a line drawn across the page. A general description of the surveyed area as a whole, with regard to topography, soil, forest cover, merchantable timber, native grasses, water supply and drainage, swamp and overflowed lands, minerals, settlement, land use, and improvements, should be supplied at the conclusion of the subdivisional notes. This general description for dependent resurveys need not be as expansive as that for original surveys. In the creation of the general description for original surveys, consideration should be given to sections 1-17, and sections 3-208 through 3-214.

**9-29.** Signed statements relating to the positions of lines or corners are placed in the field notes following the general description. The record of the names of the assistants and the certificates of the surveyor and of approval will take the forms given in the specimen field notes (section 6-21).

### Certificates

**9-30.** The executive duties appertaining to the approval, acceptance, and filing of official surveys of the Federal lands are conducted under the supervision of the BLM Director, subject to the direction and control of the Secretary of the Interior (43 U.S.C. 2; Rev. Stat. 453; 25 U.S.C. 176; Rev. Stat. 2115; 16 U.S.C. 472; 33 Stat. 628; 43 U.S.C. 1731 note; 106 Stat. 1378; 43 U.S.C. 1737(c); 90 Stat. 2766). It is proper for the Director, acting under this authority, to specify how surveys shall be made and field notes constructed.

The certificate of survey must state that the survey was executed under the direction of the assigned surveyor and in conformity with the special instructions, this Manual, and as described in the field notes. The certificate of approval must state the official approval of the field notes by the authorized official. The form and arrangement of the certificates are shown on the

specimen field notes and should be followed so far as practicable on all field notes.

The originals are signed by the authorized official. If a copy of the original is prepared by a reproduction process after signature, a properly signed certificate of transcript is required for that record.

### Reproduction and Distribution of Field Notes

**9-31.** A copy of the original field notes, designated as the duplicate original field notes, is produced using a medium that is high quality and archival. The duplicate original field notes are also referred to as “The Secretary of the Interior’s Copy” or the “Secretary’s Copy.” Descriptive Notes are no longer needed.

Triplicate original field notes, if needed, should be produced on a medium of a quality suitable for the use intended; e.g., regular quality paper, triplicate original field notes in instances where they will be used for updating other documents and then discarded, or archival quality triplicate original field notes where they are to be transferred to a State, local, Indian tribe, or Alaska native government that will use them as a permanent record. Extra and courtesy copies of the field notes produced on regular quality paper are made for official use.

**9-32.** Field notes are records vital to the mission of the BLM and are of permanent value to the Federal Government. The original field notes are permanently filed in the proper BLM state survey office, the duplicate original field notes are retained in the BLM Washington Office (44 U.S.C. 3101 and 3301). The original returns of current surveys within those States where the public survey offices have been discontinued and within the non-public land States are retained by the BLM Washington Office and currently filed at the BLM Eastern States Office at Springfield, Virginia. The duplicate original field notes and plats of such surveys are furnished to the proper State government offices, as noted in sections 1-32 and 1-33.

**9-33.** Copies will be transmitted to the entity that requested the survey. Courtesy copies of the field notes, in electronic format, must also be furnished or made available to others, as appropriate.

**9-34.** Upon official filing of a survey showing retracement or resurvey of a State boundary, copies of the field notes and plat will be provided to the appropriate State officials for each State with a letter stating the purpose of the retracement or resurvey.

## Notations, Amendments, and Corrections

**9-35.** Placing notations on filed field notes to alter, correct, or amend the official record is rarely necessary. Normally, the only notations needed are those that suspend field notes or a portion of the field notes, lift a suspension, or cancel field notes or a portion of the field notes when a corrective resurvey is filed.

Errors, if extensive enough to materially affect the survey, will be rectified by a corrective resurvey. Errors of a minor nature may not require a field note notation, as they usually do not materially affect the survey. Erroneous bearings and/or distances may be found in filed returns that do not materially affect the ground survey. Such errors may be corrected with amended field notes. Corrections of clerical errors must be documented, filed in the survey contract or group file, and a copy furnished to the custodian of the Secretary's Copy.

Notations will be authorized by memorandum from the approving official. An explanation of the notation will be documented by a memorandum to the survey contract or group file. A copy of the memorandum will be sent to the custodian of the Secretary's copy so the same notation can be placed on the duplicate original. Coordinating notations, if necessary, will be made to the plat.

Any official returns that require corrections involving line retracement or moving official corner monuments will result in a corrective resurvey plat and/or set of field notes, which, when accepted or approved, and filed, will supersede the erroneous portion of the official record.

## Specimen Field Notes

**9-36.** In the specimen field notes there are shown the several forms of description of the approved types of corner monuments. The types that are employed ordinarily are given prominence, but those that are used in exceptional circumstances are included in order to supply a form of description. The indicated departures from the usual type of monumentation are not to be construed as an authorization to disregard the standard practice.

Other specimen field notes as needed to show the miscellaneous forms of record relating to a variety of surveys found in the usual work are available in the survey offices. A liberal assortment of such field notes and their accompanying plats should be on hand for reference, since the specimen field notes cannot cover every circumstance.

## Plats

### The Importance of the Plat

**9-37.** The plat is the drawing that represents the lines surveyed, established, retraced, or resurveyed, showing the direction and length of each line; the relation to the adjoining official surveys; the boundaries, description, and area of each parcel of the land; and, as far as practicable, the topography, culture, and improvements within the limits of the survey. Occasionally the plat may constitute the entire record of the survey, with the field notes being on the plat and is herein referred to as "notes on plat."

**9-38.** The authority and jurisdiction of the Commissioner of the General Land Office, now the Director of the BLM, over the making of surveys, and specifically to require approval of those surveys, was recognized by the Supreme Court in *United States v. Morrison*, 240 U.S. 192 (1916). The Court stated that:

[I]t was competent for the Commissioner, acting within his authority, to direct how surveys should be made and to require that they should be subject to his examination and approval before they were filed as officially complete in the local land office.

The described system of survey approval is intended to ensure uniformity among survey methodologies and provide quality control.

**9-39.** Ordinarily an original survey of public lands does not ascertain boundaries, it creates them. The running of lines in the field and the platting of townships, sections, and legal subdivisions alone are not sufficient to constitute a survey. Until all conditions as to approval, acceptance, and filing have been complied with, the public lands are to be regarded as unsurveyed.

**9-40.** The public lands are not considered surveyed or identified until approval of the survey and filing of the plat in the administering land office by direction of the BLM. *United States v. Cowlshaw*, 202 F. 317 (1913). No subdivisions are to be "disposed of" until so identified. *United States v. Hurlburt*, 72 F.2d 427 (1934).

**9-41.** Although a survey may have been physically made, if it is disapproved by the authorized administrative officer, the public lands that were the subject of the survey are still classed as unsurveyed. In the event of a

resurvey, although the field work may have been completed, if it is disapproved by the authorized administrative officer, the lands that were the subject of the resurvey are not classified as resurveyed.

**9-42.** The returns of a survey are prepared, approved, accepted, and filed in the appropriate BLM office on behalf of the Director, Bureau of Land Management. The survey only becomes official when it is officially filed on behalf of the Director by the appropriate Chief Cadastral Surveyor. Any necessary suspension or cancellation of a plat or survey shall be made by the same approving authority.

**9-43.** The legal significance of plat and field notes is set out in *Alaska United Gold Mining Co. v. Cincinnati-Alaska Mining Co.*, 45 Pub. Lands Dec. 330 (1916):

It has been repeatedly held by both State and Federal courts that plats and field notes referred to in patents may be resorted to for the purpose of determining the limits of the area that passed under such patents. In the case of *Cragin v. Powell*, 128 U.S. 691, 696 (1888), the Supreme Court said:

It is a well settled principle that when lands are granted according to an official plat of the survey of such lands, the plat itself, with all its notes, lines, descriptions and landmarks, becomes as much a part of the grant or deed by which they are conveyed, and controls so far as limits are concerned, as if such descriptive features were written out upon the face of the deed or the grant itself.

These legal principles apply to subsequent deeds of transfer related to the official plat.

**9-44.** Whether so stated in the conveyance document or not, the land description is understood to reference the latest appropriate official plat, generally, as of the date the right to the estate or interest vested. Every land description shall be in conformity with the referenced plat, i.e., the boundary lines of the subdivision, unit, lot, parcel, or tract being described shall be specifically delineated on that plat.

**9-45.** In cases where the lines are not designated as noted above, it shall be necessary to have a supplemental plat prepared, accepted, and filed before the conveyance document can be issued. This will often be the

case for subdivision of lots, special survey parcels, or rights of way, for example.

**9-46.** The subdivisions are based upon and are defined by the monuments and other evidences of the controlling official survey. As long as these evidences are in existence, the record of the survey is an official exhibit and, presumably, correctly represents the actual field conditions. If there are discrepancies, the record shall give way to the evidence of the corners in place. This principle is set out in *Ogilvie v. Copeland*, 145 Ill. 98 (1893):

The field-notes and plat are assumed to be correct, until the contrary is shown, and they are important evidence in ascertaining where monuments are located; but if the location of the monument is clearly shown by other evidence to be at a distance different than that given in the field-notes and plat, they must give way.

**9-47.** In the absence of evidence, the field notes and plat are the best means of identification of the survey and they will retain this purpose. In the event of a resurvey they provide the basis for the dependent method and the control for fixing the boundaries of alienated lands by the independent method. When the alienated lands and the remaining Federal interest lands have been resurveyed, the plat of the resurvey becomes in turn the exhibit of the true conditions on the ground.

### Specimen Plats

**9-48.** The specimen plats are representations of a variety of plats produced over the last several years designed to indicate many typical features. An effort has been made to secure maximum clarity of the essential features of the survey with a standardization of the lettering that refers to section numbers, lot numbers, areas, and lengths and directions of lines, in suitable styles, all in conformity with relative importance. The style of lettering that has been selected is intended to combine the greatest possible simplicity of execution with minimum liability of loss of definition in reproduction.

The specimen plats show the basis for computing areas. The distances noted in parentheses are the regular and excess or deficiency in measurement portions of lines that constitute the boundaries of the quarter-quarter sections and other legal subdivisions.

**9-49.** Parenthetical distances are employed where the record is not supplied by the field notes; the lengths indicate what was used in the calculation of areas. The same lengths are adopted proportionately in establishing





as it is of archival quality. The inking on mylar is to be run through a process to assure the lettering is stable. The same requirements apply to supplemental plats and protraction diagrams.

Township plats are generally drawn on the scale of 1 inch equals 40 chains, on sheets 18 x 24 inches with a minimum 1 inch margin on all sides. Some flexibility in the standard sheet size is allowed in order to accommodate filing devices, and the size of the borderline rectangle may also be varied slightly when necessary. Generally the drawing is placed to the left of the center of the sheet, thus allowing space for the memorandum and other data on the right side of the plat.

Plats showing smaller subdivisions, parcels, etc. may be drawn at a variety of scales. The selection of scale should be chosen to maximize the overall size of the surveyed area and allow ease of readability of any detail. In general, even scales are desirable, such as 20, 10, or 5 chains per inch, or 1000, 500, 400, or 200 feet per inch.

Each plat or sheet of multiple sheet plats, should include the title, subtitle, north arrow, a bar or graphic scale stating the unit of measurement used on the plat, and the certificate of acceptance. Enlarged diagrams drawn to scale should also have separate graphics scales. Where necessary to indicate detail, an enlarged diagram may occasionally be drawn in an exaggerated form and accompanied by a "Not to Scale" notation.

**9-54.** In the past, plats were drawn manually and drafted as a plane, without allowance for reduction from the spheroid. However, the use of automated plat drafting systems accommodates drafting of the base drawing from any of a number of coordinate systems. This is acceptable as long as the plat, north arrow, and border lines are correctly oriented with reference to the true meridian. Bearings are stated in terms of angular measure referred to the true meridian as defined by the axis of the earth's rotation and are mean bearings. Distances are stated as if measured at the mean elevation, and areas returned are computed at mean elevation. Exceptions will be clearly labeled.

For original surveys, *regular* townships are laid out as a rectangular grid, with allowance for the excess or deficiency in measurement along the north tier and west range of sections.

In the case of *irregular* townships, invaded townships containing meanderable bodies of water, irregular or nonrectangular claims, parcels, or tracts, the drawing should be laid out from the field note data duly balanced.

It is usually sufficient to show only the true line data on the plat when the field procedure results in ascertaining the course and length of the lines being established.

**9-55.** Plats of entire townships show the complete condition of all exteriors, including closing and standard township and section corners, with connecting courses and distances (figure 9-2). The connecting courses and distances are omitted where the scope of the work is not sufficient to determine the relationship accurately.

A line common to two townships is drawn with equal completeness for both in cases where the two are surveyed concurrently and shown on separate plats. The relative position of and the data for nearby corners of one or two townships and township corners established at intersection are shown. Corners of maximum control are shown only as referring to the subdivisional survey on that plat. Separate diagrams of township exteriors are not required when the townships are subdivided.

**9-56.** The boundary of a State, surveyed reservation, or private land grant is lettered on the plat, and connecting bearings and distances are shown from line intersections to the mile posts. The tie to a geodetic reference monument from a monumented corner of the survey must show the datum, mean bearing, and ground distance, unless labeled otherwise.

**9-57.** Where only a portion of a township is being surveyed, the condition of the adjacent areas is shown clearly by words lettered thereon, such as "Unsurveyed," "Rancho San Luis," "Surveyed by John Smith, 1877," "Resurveyed by Susan Acres, 1999," and "Waste Lava Bed."

**9-58.** On plats of fragmentary surveys, areas previously surveyed do not have the sections and lots drawn in unless needed to show the relation of the old and new work along the common boundary. When the configuration and identification of adjacent parcels is necessary they may be depicted with "ghost" or dotted line work and lettering.

**9-59.** The line of demarcation between areas previously counted in the total acreage surveyed or resurveyed and the new surveys is distinctly shown. A light diagonal shading with black ink on the side previously surveyed is recommended to distinguish such a line.

**9-60.** Each regular section in an original survey plat shows the center lines only and the area as 640 acres. In other sections where lottings are required, each subdivision must be distinctly shown. Where a section





**9-64.** An alternative method would be to determine the difference between the distances of the north and south boundaries of the section. This can then be divided by the total distance along the west boundary of the same section, times the length of each segment (quarter distance) of said boundary to give an amount to either be added to or subtracted from the distance on either the north or south boundaries of the sections to obtain the measurements to be used for the area computation.

**9-65.** The surplus or deficiency in area that results from the discrepancy in the meridional measurements between the exterior boundaries and the subdivisional lines is placed normally in the lots adjoining the north boundary of the township.

Sections 1 through 5 each usually contains lots 1 through 4, whose dimensions on their latitudinal boundaries are all treated as an even 20.00 chains; the meridional dimensions of these lots and their areas are computed on the plan heretofore described for the lots adjoining the west boundary of the township.

**9-66.** The areas of lots 1, 2, and 3, section 6, are ascertained similarly, making due allowance when calculating the length of the west boundary of lot 3, for the departure across lot 4, where more or less than 20.00 chains. The area of lot 4, section 6, in acres, equals the product of its mean dimensions in chains, divided by 10.

**9-67.** The following is an example of ascertaining the areas of the regular lots in section 6, shown on the specimen original survey plat, appendix I:

	(1)	(2)	(3)	(4)	
E.	20.02	20.015	20.01	20.005	chs.
W.	20.015	20.01	20.005	20.000	chs.
	<u>40.035</u>	<u>40.025</u>	<u>40.015</u>	<u>          </u>	acres
	40.03(+)	40.03(-)	40.01(+)		acres
				<u>20.003</u>	mean
	(5)	(6)	(7)		
N.	17.78	17.81	17.84	17.75	chs.
S.	17.81	17.84	17.87	17.78	chs.
	<u>35.59</u>	<u>35.65</u>	<u>35.71</u>	<u>          </u>	acres
				<u>17.765</u>	mean
	2.0003 x 17.765 =			35.535	acres
				35.53(+)	acres

**9-68.** In irregular sections and in sections that are invaded by meanderable bodies of water, or by lines of segregation, the center lines of the section and the center lines of each

quarter section in turn are given calculated values based upon the balanced data obtained from the field note record or the best available raw field data. Points of intersection of the center lines with the meander lines or other lines of segregation are then computed in order to complete the boundaries of each irregular lot. With the results of these computations at hand the area of each irregular lot may be most readily computed by the method of “double meridian distances” (D.M.D.).

**9-69.** The method used to perform automated computation should follow the D.M.D. method. This method is described in many textbooks and is preferred to avoid large errors that can arise from coordinate based methods.

In order to compute an area by D.M.D., the closing error of the figure is eliminated, or the traverse of its boundary is balanced, by the compass rule. This rule restated is that the correction to be applied to the  $\left\{ \begin{matrix} \text{latitude} \\ \text{departure} \end{matrix} \right\}$  of any course is to the total error in  $\left\{ \begin{matrix} \text{latitude} \\ \text{departure} \end{matrix} \right\}$  as the length of the course is to the perimeter of the figure. This adjustment is based upon the record data. It is not necessary to attempt to correct the figure closure for apparent misclosure due to convergency of the meridians.

The D.M.D. of the several courses are then computed by the following rules:

- (1) The D.M.D. of the first course equals the departure, or the increment in easting or westing, of the course itself;
- (2) The D.M.D. of the second course, and each of the succeeding courses in turn, is ascertained by taking the D.M.D. of the preceding course, plus the departure of the preceding course, plus the departure of the course itself; and,
- (3) The D.M.D. of the last course is numerically equal to its departure, but with opposite sign, thus verifying the value of each preceding D.M.D.

For convenience in making the computations, the differences in  $\left\{ \begin{matrix} \text{latitude} \\ \text{departure} \end{matrix} \right\}$  to the  $\left\{ \begin{matrix} \text{north} \\ \text{east} \end{matrix} \right\}$  are treated as of positive sign, to the  $\left\{ \begin{matrix} \text{south} \\ \text{west} \end{matrix} \right\}$  as of negative sign.

The next step is to multiply the latitude of each course by the D.M.D. of the course; the positive products are arranged in a column for “north areas,” and the negative

products in a column for “south areas.” The sum of the negative products is subtracted from the sum of the positive products. The area, corresponding to the unit of measurement that is employed, is ascertained by taking one-half of the last result. Where the unit of measurement is the chain, the area in square chains is divided by 10 to give the area in acres.

Examples of D.M.D. calculations are shown in tables 9-2 through 9-5.

**9-70.** The use of computer software and automated drafting systems affords a fast method of calculating the area of irregular land and water forms. In all cases the data used in the area computation must be the same as that used and depicted as record on the plat and in the field notes. Care must be taken to assure that computation of area is not based upon unrounded or preliminary field data, grid data, etc. For example, an area of a figure is easily obtained directly from many automated mapping systems utilizing State plane, Universal Transverse Mercator (UTM) or other projected coordinate systems, yet if the base drawing is derived from rounded field

data, the areas thus computed can vary considerably from the record.

**Inking the Drawing**

**9-71.** High quality permanent ink should always be employed. The lettering should be sharp and clear, uniform in density of color, and the lettering standardized as to gage and style (figure 9-3).

Another important consideration is the size and density of information shown. Currently many public and other users of the records access them via microfilm and other imaging, scanning, and reproduction technologies. No text fonts or symbols of a very small size should be used that would make photocopied, microfilmed, or scanned images of the item illegible.

The arrangement of some of the more minute data on the specimen plats illustrates the minimum to which the work may be condensed safely. Attention is directed to the space allowed between the lettering and the adjacent lines; this is never less than the space between the upper

**Table 9-2.** Calculations of T. 15 N., R. 20 E., Diamond Rock, in Lins Lake, in section 18 (see specimen original survey field notes and plat, appendix I).

No.	Course	Distance	Latitudes		Departures		D.M.D.	N. areas	S. areas	Totals	
			North	South	East	West				Lat. N.	Dep. E.
Tie	N. 71° 30' E	21.45	6.81		20.34					6.81	20.34
5	S. 86° 46' E.	3.20		0.18	3.195	4.725		0.85		6.62	23.52
4	N. 33° 00' E.	2.20	1.845		1.20	9.12	16.825			8.465	24.72
3	N. 48° 30' W.	3.50	2.32			2.62	7.70	17.865		10.785	22.10
2	S. 61° 15' W.	2.90		1.395		2.54	2.54		3.545	9.39	19.56
1	S. 16° 30' E.	2.70		2.59	0.765		0.765		1.98	6.80	20.33
			4.165	4.165	5.16	5.16		34.69	6.375		
		14.50	4.165	4.165	5.16	5.16		28.315	Double area.		
D.M.D.											
Begin total lats. and deps. at M.C. on W. bdy. sec. 19, for purposes of platting.			(1)	0.765	9.12	(4)	14.16 Square chains. 1.42 Acres				
				+0.765	+1.20						
				+3.195	-2.62						
Numbering of courses as taken from field notes, order reversed to counterclockwise.			(5)	4.725	7.70	(3)	Begin D.M.D. at angle point of meanders farthest west, end of course No. 2 running SW., or end of course No. 1 running NW.				
				+3.195	-2.62						
				+1.20	-2.54						
			(4)	9.12	2.54	(2)					

**Table 9-3.** Calculations of T. 15 N., R. 20 E., right bank of Yellowstone River, in section 25 (see specimen original survey field notes and plat, appendix I).

No.	Course	Distance	Latitudes		Departures		D.M.D.	N. areas	S. areas	Totals	
			North	South	East	West				Lat. N.	Dep. E.
	S. 0° 01' E.	5.32		5.32	0.00		0.00			0.00	0.00
	S. 89° 57' E.	80.00		0.07	80.00		80.00	5.60		- 0.07	80.00
	North	23.20	23.20				160.00	3,712.00		23.13	80.00
1	S. 85° 00' W.	13.00		1.13	12.95		147.05	166.17		22.00	67.05
2	S. 72° 00' W.	7.10		2.19	6.75		127.35	278.90		19.81	60.30
3	S. 64° 30' W.	13.00		5.60	11.73		108.87	609.67		14.21	48.57
4	S. 40° 30' W.	5.40		4.11	3.51		93.63	384.82		10.10	45.06
5	S. 77° 45' W.	7.00		1.49	6.84		83.28	124.09		8.61	38.22
6	N. 76° 00' W.	7.40	1.79		7.18		69.26	123.97		10.40	31.04
7	S. 80° 00' W.	12.00		2.08	11.82		50.26	104.54		8.32	19.22
8	S. 81° 07' W.	19.45		3.00	19.22		19.22	57.66		5.32	0.00
			24.99	24.99	80.00	80.00		3,835.97	1,731.45		
								1,731.45			
		84.35	24.99	24.99	80.00	80.00		2,104.52	Double area.		
Begin traverse and D.M.D. at M.C. on W. bdy. of sec. 25.							1,052.26 Square chains.				
Begin total lats. and deps. at point for S. 1/16 sec. cor. on W. bdy. of sec. 25, for purposes of platting.							105.23 Acres, sum of lots 5 to 8, incl.				
Numbering of courses as taken from field notes.											

**Table 9-4.** Calculations of T. 15 N., R. 20 E., section 25, lots 5 and 6 (see specimen original survey field notes and plat, appendix I).

No.	Course	Distance	Latitudes		Departures		D.M.D.	N. areas	S. areas
			North	South	East	West			
	South	19.72		19.72					
	S. 89° 57' E.	20.00		0.02	20.00		20.00		0.40
	North	23.20	23.20				40.00	928.00	
1	S. 85° 00' W.	13.00		1.13	12.95		27.05		30.57
2	S. 72° 00' W.	7.10		2.19	6.75		7.35		16.10
3	S. 64° 30' W.	0.33		0.14	0.30		0.30		0.04
			23.20	23.20	20.00	20.00		928.00	47.11
								47.11	
								880.89	
								44.04	Lot 5
	South	9.04		9.04					
	S. 89° 57' E.	20.00		0.02	20.00		20.00		0.40
	North	19.72	19.72				40.00	788.80	
3	S. 64° 30' W.	12.67		5.45	11.43		28.57		155.71
4	S. 40° 30' W.	5.40		4.11	3.51		13.63		56.02
5	S. 77° 45' W.	5.18		1.10	5.06		5.06		5.57
			19.72	19.72	20.00	20.00		788.80	217.70
								217.70	
								571.10	
								28.55	Lot 6

**Table 9-5.** Calculations of T. 15 N., R. 20 E., section 25, lots 7 and 8 (see specimen original survey field notes and plat, appendix I).

No.	Course	Distance	Latitudes		Departures		D.M.D.	N. areas	S. areas
			North	South	East	West			
	S. 0° 01' E.	8.48		8.48					
	S. 89° 57' E.	20.00		0.02	20.00		20.00		0.40
	North	9.04	9.04				40.00	361.60	
5	S. 77° 45' W.	1.82		0.39		1.78	38.22		14.91
6	S. 76° 00' W.	7.40	1.79			7.18	29.26	52.37	
7	S. 80° 00' W.	11.21		1.94		11.04	11.04		21.42
			10.83	10.83	20.00	20.00		413.97	36.73
								36.73	
								377.24	
								18.86	Lot 7
	S. 0° 01' W.	5.32		5.32					
	S. 89° 57' E.	20.00		0.02	20.00		20.00		0.40
	N. 0° 01' W.	8.48	8.48				40.00	339.20	
7	S. 80° 00' W.	0.79		0.14		0.78	39.22		5.49
8	S. 81° 07' W.	19.45		3.00		19.22	19.22		57.66
			8.48	8.48	20.00	20.00		339.20	63.55
								63.55	
								275.65	
								13.78	Lot 8

two points of the gage for the lettering; this is the rule where the drawing is to be reproduced at the same scale; proportionately more space should be allowed on special drawings where a reduction of scale is to be made on reproduction. The same safeguards should be applied in spacing the adjoining letters, and it will be noted that the spacing between letters bears a definite relation to the gage employed.

**9-72.** Corner symbols have been standardized (table 9-6). If corner symbols are used, a legend on the plat is necessary:

**Lettering**

**9-73.** Generally all letters and figures are drafted in pure Gothic style. The use of automated drafting systems makes this relatively easy, but care should be taken to use a font or character set that is consistent with that shown on the specimen plats. Of particular concern are well formed and distinguishable numbers and symbols such as the degrees symbol. It is generally preferable to show data that is in tables with a mono-spaced font so that the data is aligned vertically. All other lettering should be of proportionally spaced type for the best and most efficient appearance. The specimen plats and other

illustrations of the Manual should provide a guide to the appropriate uses of both slanted and vertical lettering.


Figure 9-3 shows the usual styles and sizes to be followed in preparing a plat on the scale of 1 inch equals 40 chains; the number of the guide refers to thousandths of an inch. The guidelines contained in figure 9-3 apply to a full township plat, and will be varied appropriately for other scales. While some may consider the need to control line weights and letter sizes as an unnecessary


Plat corner symbols.

△	Control Station
◇	Original Corner
◆	Original Corner Remonumented
□	Local Corner Accepted
■	Local Corner Monumented
○	Proportioned Point
●	Proportioned Point Remonumented or New Corner Monumented
	No symbol or tick mark - Point Not Monumented



Figure 9-3. Lettering styles used on a full township plat.

<u>Description</u>	<u>Lettering Style</u>	<u>Guide - Pen Size</u>
Plat Heading	TOWNSHIP I NORTH	240 - 0.80mm
Subtitle	DEPENDENT RESURVEY SUPPLEMENTAL PLAT	175 - 0.60mm
North Arrow		80 - 0.30mm
Section Number	Sec. 16	120 - 0.35mm
Area (section)	160, 639.54	100 - 0.25mm
Lot Numbers & Area	10 39.95	60 - 0.18mm
Bearing	N. 89°58' W.	80 - 0.18mm
Distance	79.95	80 - 0.18mm

<u>Description</u>	<u>Lettering Style</u>	<u>Guide - Pen Size</u>
Witness Corner	<i>W.C., N.0°05'W., 0.50</i>	60 - 0.18mm
Proper Names	<b>LAKE CITY TOWNSITE</b>	100 - 0.30mm
Descriptive Names	Ivy Island, Alkali Flat	80 - 0.25mm
Hydrographic Names	<i>YELLOW RIVER</i>	100 - 0.30mm
	<i>Clear Lake</i>	100 - 0.30mm
	<i>Canal, Spring, Aqueduct, Clear Cr.</i>	80 - 0.25mm
Mineral Survey	M.S. No. 2053	80 - 0.25mm
Lode or Placer Name	NUGGET	80 - 0.25mm
Scale	 <p>Scale in Chains</p>	60 - 0.18mm
		80 - 0.25mm
Extra Sheets	<b><i>SHEET 1 OF 3</i></b>	140 - 0.50mm
Control Station	ROUNDUP 1942 U. S. C. & G. S. NORTH PEAK 1957 U. S. G. S.	60 - 0.25mm
Guide Meridian	<b><i>FIRST GUIDE MERIDIAN EAST</i></b>	120 - 0.35mm
Standard Parallel	<b><i>SECOND STANDARD PARALLEL SOUTH</i></b>	
Sectional Correction Line	<i>CORRECTION LINE</i>	80 - 0.25mm
Jurisdictional Lines	<b>STATE BOUNDARY LINE</b> <b>INDIAN RESERVATION BOUNDARY</b> <b>MILITARY RESERVATION BOUNDARY</b>	140 - 0.50mm
Geographic Position	Latitude 48° 17' 46.753" N. Longitude 121° 35' 15.581" W. (NAD 83)	80 - 0.25mm

aesthetic exercise, in fact the use of varying sizes and styles of lettering is designed to allow easier interpretation of the plat. In this regard a general rule to follow is to graduate both the line weight and width and the lettering size based upon the hierarchy of the line, graduating to more fine line work and smaller lettering on the most minor subdivisions.

The judicious use of line weights or widths and different sizes of lettering is recommended as discussed above. The weight of line work has historically been determined by standard drafting pen widths. In the movement to automated systems, line widths may be produced by alternative methods and drafting pen sizes are currently available in metric sizes.

While different manufacturers have different equivalents, table 9-7 provides an example of conversion useful in the charts.

**Table 9-7.** Line weight conversions.

Pen Size	Typical Metric Widths
0000 or 4x0	.18mm
000 or 3x0	.25mm
00	.30mm
0	.35mm
1	.50mm
2	.60mm
2.5	.70mm
3	.80mm
3.5	1.00mm

Care should be taken as to what items are to be indicated with slant lettering versus vertical lettering, and the specimen plats serve as a guide for this. In general dimensions, road and river names are in slanted lettering. Consistency is important in providing a readable and understandable product for public use.

At this stage of the drafting work attention should be given to the showing of the directions and lengths of all necessary connecting lines, in addition to the data that ordinarily appears on the section boundaries. The requirements are set out in sections 3-40, 3-77, 3-188 and 3-189, 3-198, and 4-16. Additional sheets, drawn to a larger scale, are used to show the detail of complicated situations (figure 9-1 and section 9-51).

## Topography

**9-74.** Generally only the most essential topographic data need be shown upon the plat. Some plats may not

require the showing of any topography, others may require the showing of many different features, where the drawing in addition to being a plat may be a complete topographic map. The topographic map features are delineated by the standard symbols adopted by the U.S. Geological Survey.<sup>1</sup> A summary of what is required is contained in section 3-222.

In the preparation of the drawing the first question to be considered, after the completion of the base and before adding the topography, is how the important map features are to be shown without obscuring the base data. In simple cases all work may be done readily in black ink on the base drawing. Good judgment should be exercised regarding what is essential, and how the essential things may be shown without unwarranted cost.

**9-75.** Any needed map features or groups of features are usually delineated upon the base drawing in black ink (table 9-8).

**Table 9-8.** Map features delineated as simple drawings, all black.

Low relief	Black hachure.
Roads and highways	Black lines, parallel.
Trail	Black line, broken.
Culture	Black pattern.
Alkali flats	Black depression-contour and pattern.
Sand dunes	Black pattern.
Water surface, large rivers and lakes	Black meander line, without water lines.
Minor drainage	Black line, or broken line and dots.
Wide sandy bottomed draws	Black pattern.
Ponds	Black pattern.
Marsh	Black pattern.
Timber	Marginal note.

**9-76.** The availability of well-prepared topographic maps of much of the Federal land area makes it less important to show upon the plat all of the detail relating to topography, culture, and improvements. However, it is still necessary to show the major items of topography and improvements in their correct relationship, especially close to corners of the survey and items of topography and improvements returned in the original survey.

<sup>1</sup> Standard symbol sheet may be obtained from the Director, U.S. Geological Survey, Reston, VA 20192, [www.usgs.gov](http://www.usgs.gov).

The special instructions for each survey should outline any exceptional methods to be employed in the field in obtaining topographic data. The field sketch plat should represent the situation on the ground with an accuracy in details that reflects the practical relative importance.

Occasionally, in connection with dependent resurveys, for example, the development of map data may even precede other parts of the survey work. The map data may be valuable in making searches for and restorations of lost or obliterated corners and for locating roads, improvements, and cultivated tracts upon patented and entered lands. The map features of the plat are also important in certain classes of surveys within Indian and forest reservations, coal fields, mineral areas, waterpower sites, reservoir sites, irrigation projects, swamp and overflowed lands, and other regions of relatively large prospective value.

**9-77.** The names of natural features must be given according to accepted usage. Surveyors are not authorized to report names of their own selection, but in case of doubt may submit the question through official channels to the United States Board on Geographic Names.

### Titles and Subtitles

**9-78.** Every plat is given a title similar to that on the specimen plats. This shows the township, range, meridian, and the State. Plats showing the original subdivision of only a portion of a township are usually given a similar title for the sake of simplicity. Supplemental plats, plats of fragmentary subdivisional surveys, and resurvey plats are given an appropriate subtitle to qualify the nature of the survey. The title and date of acceptance and filing usually suffice to identify the plat. The subtitle, if employed, explains the special purpose of the plat.

**9-79.** A subtitle is modeled after one of the following forms:

- (1) Supplemental Plat
- (2) Four Islands in Burntside Lake
- (3) Extension Survey
- (4) Dependent Resurvey
- (5) Independent Resurvey
- (6) Survey of Omitted Lands
- (7) Survey of Accretion Lands

- (8) Survey of Tracts 37 and 38
- (9) Subdivision of Sections
- (10) Survey of Hiatus
- (11) Survey of the Moore Coal Mine
- (12) Poplar Townsite
- (13) Segregation Survey
- (14) Protracted Township
- (15) Corrective Dependent Resurvey

Only the main purpose of the plat is included in the subtitle. The detail is carried in the memorandum.

### Memorandum

**9-80.** A memorandum is required on each plat to correlate and consolidate the record of the existing surveys so far as shown on that plat. This memorandum will have a wide variety of references. The simple form shown on the specimen plats are extended as required.

The memorandum will state that the corner descriptions and other relevant information is contained in the field notes. Where the plat represents the entire record of the survey, a statement to that effect will be placed on the plat.

**9-81.** A north arrow symbol is shown to indicate the line of the true meridian. The mean magnetic declination over the area surveyed, when determined, is shown at the base of the north arrow (section 3-223(15)).

The latitude and longitude are shown for any corner and lettered on the plat at that point. The level of precision shown should be indicative of the best available data (section 2-32).

Each plat of an original survey carries a note of the total area surveyed, derived by taking the sum of all sectional-total areas that are identified by that plat. If resurveys are involved the rule is stated in sections 9-122 and 9-146.

The scale of the plat is shown by means of a bar scale.

### Certifications

**9-82.** The executive duties appertaining to the approval, acceptance, and filing of official surveys of

the Federal interest lands are conducted under the supervision of the Director, Bureau of Land Management, subject to the direction and control of the Secretary of the Interior (43 U.S.C. 2; Rev. Stat. 453; 25 U.S.C. 176; Rev. Stat. 2115; 16 U.S.C. 472; 33 Stat. 628; 43 U.S.C. 1731 note; 106 Stat. 1378; 43 U.S.C. 1737(c); 90 Stat. 2766). It is proper for the Director, acting under this authority, to specify how surveys shall be made and plats constructed.

The certificate shows official acceptance of the survey as represented on the plat. The form and arrangement of the certificate of acceptance are shown on the specimen plats and should be followed so far as practicable on all plats. The date of official filing will be on the face of the plat.

For notes on plat returns, the certificate will be modified to read:

The survey represented by this plat, having been correctly executed in accordance with the requirements of law and the regulations of this Bureau, is hereby accepted.

For the Director

Chief Cadastral Surveyor for Alaska

The original is signed by the authorized official. If a copy of the original is prepared by a reproduction process after signature, a properly signed certificate of transcript is required for that record.

### Reproduction and Distribution of Plats

**9-83.** A copy of the original plat, designated as the duplicate original plat is produced using a medium that is high quality and archival, see section 9-53. The duplicate original plat is also referred to as “The Secretary of the Interior’s Copy” or the “Secretary’s Copy.”

A triplicate original plat, if needed, should be produced on a medium of a quality suitable for the use intended; e.g., regular quality paper, triplicate original plat in instances where they will be used for updating other documents and then discarded, or archival quality triplicate original plat where they are to be transferred to a State, local, Indian tribe, or Alaska native government that will use them as a permanent record. Extra and courtesy copies of the plats produced on regular quality paper are made for other uses.

**9-84.** Cadastral survey plats, including supplemental plats and protraction diagrams, are records vital to the mission of the BLM and are of permanent value to the Federal Government (44 U.S.C. 3101 and 3301). The original plats, supplemental plats, and protraction diagrams are officially filed in the proper BLM state survey office; the duplicate original plats and protraction diagrams are retained in the Washington Office. The original returns of current surveys within those States where the public survey offices have been discontinued and within the non-public land States are retained by the BLM Washington Office and currently filed at the BLM Eastern States Office at Springfield, Virginia. The duplicate original plats and field notes of such surveys are furnished to the proper State government office, as noted in sections 1-32 and 1-33.

**9-85.** Copies will be transmitted to the entity that requested the survey. Courtesy copies of the plat(s), in electronic format, must be furnished or made available to others, as appropriate.

**9-86.** Upon official filing of a plat showing a retracement, resurvey, or protraction diagram adjoining a State boundary, copies of the plat and field notes will be provided to the appropriate State officials with a letter stating the purpose of the retracement, resurvey, or protraction diagram.

### Notations, Amendments, and Corrections

**9-87.** Placing notations on filed plats and protraction diagrams to alter, correct, or amend the official record is rarely necessary. Normally, the only notations needed are those that suspend a plat or a portion of a plat, lift a suspension, or cancel a plat or a portion of a plat when a corrective resurvey plat is filed.

Errors, if extensive enough to materially affect the survey, will be rectified by a corrective resurvey. Errors of a minor nature may not require a plat notation, as they usually do not materially affect the survey. Erroneous bearings and/or distances may be found in filed returns that do not materially affect the ground survey. Such errors may be corrected with an amended plat. Corrections of clerical errors will be documented and filed in the survey contract or group file, and a copy furnished to the custodian of the Secretary’s Copy.

Notations must be authorized by memorandum from the approving official. An explanation of the notation will be documented by a memorandum to the survey contract or group file. A copy of the memorandum will



be sent to the custodian of the Secretary's Copy so the same notation can be placed on the duplicate original. Coordinating notations, if necessary, will be made to the field notes.

Any official returns that require corrections involving line retracement or moving official corner monuments will result in a corrective resurvey plat and/or set of field notes, which, when accepted or approved, and filed, will supersede the erroneous portion of the official record.

### Supplemental Plats

**9-88.** A supplemental plat is prepared entirely from office records and is designed to show a modified subdivision of one or more sections without change in the section boundaries and without other modification of the subsisting official record.

**9-89.** Supplemental plats are required where the subsisting plat fails to provide units suitable for administration or disposal, or where a modification of its showing is necessary. They are also required to show the segregation of alienated lands from Federal interest lands where the former are included in irregular or nonrectangular surveys of patented mineral or other private claims made subsequent to the plat of the subsisting survey or where the segregation of the claims was overlooked at the time of its approval.

**9-90.** When it is anticipated that lands will be subdivided into aliquot parts of less than 2½-acres, a supplemental plat should be prepared and lot numbers assigned. Legal descriptions by aliquot part will not go beyond a four component description. In theory, aliquot parts can be divided *ad infinitum*. However the lengthy descriptions that result from this practice tend to invite error in the preparation of documents and in recordation. It also further complicates the maintenance and interpretation of the land records. For example, a 5-acre unit described as the S½NE¼NW¼SE¼ is acceptable, as is a 2½-acre unit described as the SE¼NE¼NE¼SW¼. Aliquot parts of 1¼-acre or less described with five components or more, e.g., the W½SE¼NE¼SW¼SE¼ are unacceptable.

**9-91.** All supplemental plats will show a proper reference to the former plat, the purpose of and the authority for the preparation, and all essential data, without unnecessary duplication of that carried by the former plat. The scale of the supplemental plat may be enlarged to 1 inch equals 10 or 20 chains, as appropriate.

**9-92.** The new lots are numbered as required in sections 3-96 and 3-110, and proper areas returned. The areas of the lots are computed from the subsisting record, including the data derived by retracements where field work is required and other survey records acceptable to the approving official. The results of the computations will ordinarily require some proportionate adjustment to secure a sum of the several parts within each legal subdivision equal to the area returned on the former plat. No revision of the total area within the section is required. Unless the retracements show an excessive discrepancy in the record, as defined by sections 3-217 and 9-109, the areas derived by exact calculation will be employed. Generally there is no occasion for showing topography.

**9-93.** Where information reveals gross distortion in the section, or where a nonrectangular survey, such as a mineral survey executed subsequent to the survey of record, could create lots that do not exist in fact or not create lots that do exist in fact, or could cause the remainder of the section to be out of limits, a survey will be considered in lieu of a supplemental plat.

**9-94.** The modified lottings on supplemental plats resulting from special surveys are not confined to the subdivisions embraced within the pending entry or selection. It is desirable to lot all Federal interest land within the scope of the plat to avoid later piecemeal preparation of additional supplemental plats.

**9-95.** The plat should show an appropriate direct tie between a claim and a section corner or distances along claim and section lines to points of intersection. Complete courses and distances are shown for the claim lines that bound the Federal interest lands.

The lengths of lines are typically expressed in feet in the record of a mineral survey and in chains in the record of the rectangular net. Whenever the segregation of mineral claims is involved, the values on the face of the drawing are given in one unit only.

**9-96.** The authority for the preparation of supplemental plats issues only from the BLM Director. The specific purpose to be served and the details involved are included in the authorization signed by the Chief Cadastral Surveyor or request signed by the requesting official. In every instance the status of the surrounding subdivisions must be examined prior to authorization and care exercised that no changes are contemplated that will affect any adjoining alienated land. If field work or examinations of other records are necessary in order to prepare the plat, the regular procedure outlined for

executing a dependent resurvey will be followed. The administrative determination of the need for a supplemental plat rests with the appropriate Chief Cadastral Surveyor, subject to the plat's acceptance for the BLM Director, and filing in the official survey records.

**9-97.** Upon the determination by the approving official of the requirement for a supplemental plat, special instructions giving the detailed specifications will be set out, prepared, signed, and approved. Assignment instructions will be issued. A survey group file will be created and contain the entire record of the supplemental plat process.

**9-98.** County and other local surveys, including administrative surveys, may be used to develop supplemental plats. For local survey data to qualify for the Director's acceptance, it will be subjected to a careful examination to insure that it conforms to Manual requirements. The use of local surveys for this purpose should be performed on a limited basis and only when there is a special need and established criteria are met.

Before a nonofficial record is used it is examined, followed by field checks if necessary. The examination will include, but not be limited to, the following:

- (1) Gather and thoroughly review all pertinent records including land status (Federal and non-Federal), land descriptions, official surveys, and local surveys.
- (2) Check all calculations. Areas that do not close within the rectangular limits, or within the closure limits specified by the special instructions, will be identified for review by the approving official to determine acceptability or identification of necessary field work.
- (3) Determine the basis of bearing. If the bearings were not determined with reference to the true meridian as defined by the axis of the earth's rotation, field work may be necessary to determine the appropriate bearing rotation.
- (4) Determine if the survey has been tied directly into an official survey. If the tie is indirect or the official survey obliterated, field work may be necessary.
- (5) Evaluate existent and obliterated corner determinations. Is the corner position evidence conclusive? Is the chain of survey complete? Are the corners monumented and uniquely

identifiable? Are there conflicting positions for the corner? Identify questionable determinations for field evaluation.

- (6) Evaluate the methods used for reestablishing lost corners, including proportioning accuracy and verification of record information. Apparent discrepancies may require a field check.
- (7) Identify all lost corners to be searched for in the field.
- (8) Evaluate local corners for conformity with Manual guidelines.
- (9) Determine if the procedures used to subdivide sections or perform nonrectangular surveys are in accordance with the Manual.
- (10) Determine if common boundaries may in fact overlap or not meet. This type of discrepancy is increased when irregular or nonrectangular boundaries are involved. Are lines of occupation in agreement with record lines? Are physical improvements located within record boundaries? May unrecorded rights exist?

**9-99.** The supplemental plat official record will consist of an official plat and the survey group file. Records used for the preparation of the supplemental plat are office records and copies are retained in the survey group file. The survey group file must contain corner description information, copies of local surveys, examination reports, the authorization or request, special instructions, assignment instructions, and other relevant materials.

The survey group number, the dates of the authorization or request, special instructions, and assignment instructions, along with the beginning and completion dates will be on the plat. See section 9-84 for reproduction and distribution of supplemental plats.

If data from a nonofficial survey is utilized, the following additional information will be on the plat:

- (1) Rotation to true meridian, if applicable, based upon office examination or field verification.
- (2) History of local surveys.

The certificate of acceptance follows the arrangement shown on the specimen supplemental plat in

appendix IV and the memoranda include the pertinent data involved in the preparation of the plat, modified as may be appropriate.

Following are examples for supplemental plats.

**9-100.** Figure 9-4 illustrates:

A modified form of lotting to provide new descriptions, based entirely upon records on file in this office, and without additional field work.

Title: Township 8 North, Range 20 West, of the San Bernardino Meridian, California. Subtitle: Supplemental Plat.

Scale: Bar scale in chains (or units).

Memorandum:

This plat showing a subdivision of original lots 3 and 4, sec. 19, T. 8 N., R. 20 W., S.B.M., California, based upon the plat approved October 8, 1880, is prepared to accommodate Federal Land Policy and Management Act sale CACA-035503. Plat prepared by Larry H. Daniels, Cadastral Surveyor, beginning May 18, 2009, and completed June 1, 2009, pursuant to special instructions dated and approved May 14, 2009, and assignment instructions dated May 15, 2009, for Group No. 7344, California.

Certificate: Heading similar to that shown on the specimen supplemental plat, appendix IV.

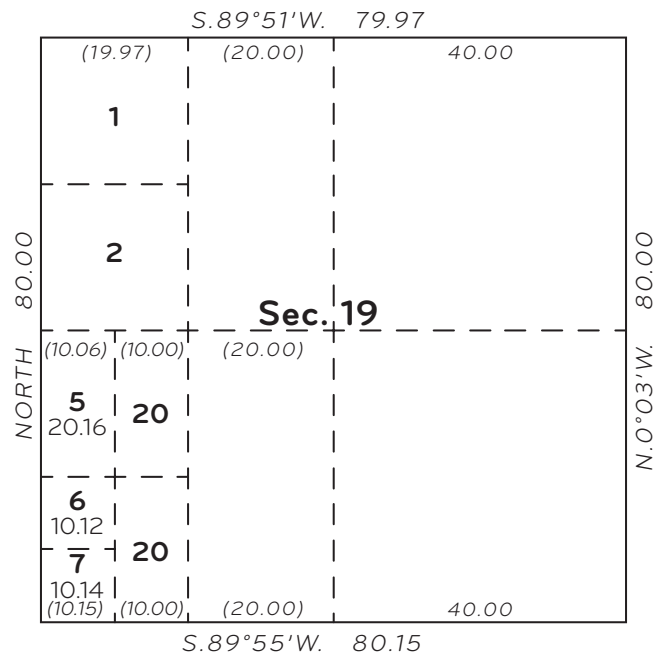
This plat, showing amended lottings, is based upon the official records and, having been correctly prepared in accordance with the requirements of the law and the regulations of this Bureau, is hereby accepted.

For the Director

Chief Cadastral Surveyor for California

**9-101.** Figure 9-5 illustrates:

A modified lotting made subsequent to a Forest Homestead Entry Survey and National Forest System Lands Small Tract surveys, based entirely upon the public land and forest survey records on file in the Bureau of Land



**Figure 9-4.** Accommodation of a land sale by providing new descriptions; E½NW¼SW¼ and lot 7, section 19.

Management, Montana State Office, Billings, Montana, and without additional field work.

Title: Township 5 South, Range 5 East, of the Black Hills Meridian, South Dakota. Subtitle: Supplemental Plat.

Scale: Bar scale in chains (or units).

Memorandum:

This plat of section 15, Township 5 South, Range 5 East, of the Black Hills Meridian, South Dakota, based upon the plat approved May 23, 1899, showing amended lottings created by the segregation of Forest Homestead Entry Survey No. 477, accepted June 30, 1917, and National Forest System Lands Small Tract surveys dated September 10, 2001, and January 23, 2006, respectively, is prepared to accommodate additional National Forest System Lands Small Tract sales MTSD-124993 and 124994. Plat prepared by C. Albert Berlin, Cadastral Surveyor, beginning May 18, 2010, and completed June 1, 2010, pursuant to special instructions dated May 13, 2010, and approved May 14, 2010, and assignment instructions dated May 17, 2010, for Group No. 3211, South Dakota.

Certificate: Heading similar to that shown on the specimen supplemental plat, appendix IV.

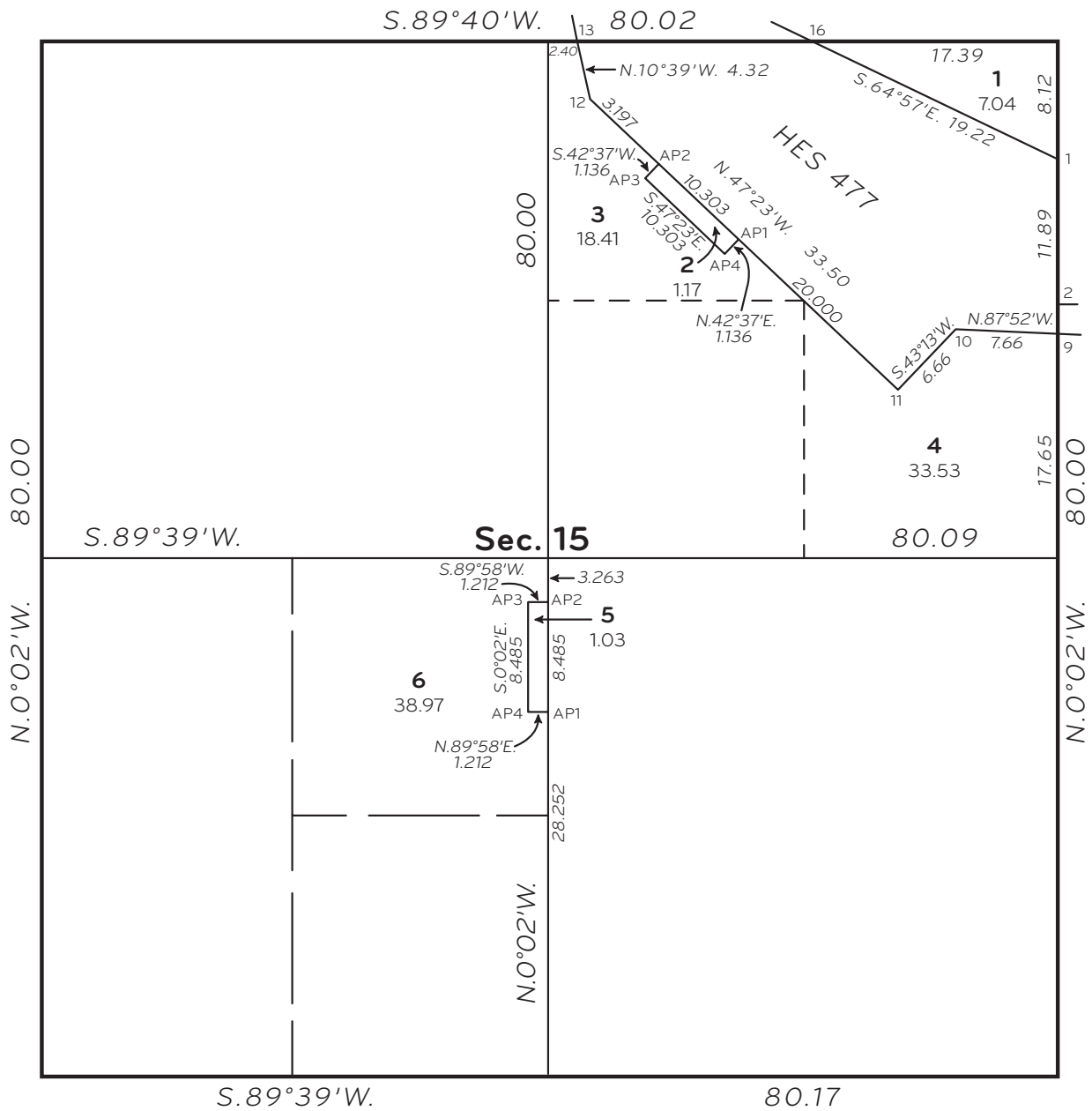


Figure 9-5. Supplemental plat for accommodation of National Forest System Lands Small Tract sales.

This plat, showing new lots, is based upon the official records and, having been correctly prepared in accordance with the requirements of the law and the regulations of this Bureau, is hereby accepted.

For the Director

Chief Cadastral Surveyor for South Dakota

**9-102.** Figure 9-6 illustrates:

Segregation of mineral claims, based entirely upon the public land and mineral survey records on file in this office, and with additional field

work. The data shown in parentheses along the lot boundaries are derived by calculation.

Title: Township 9 North, Range 2 West, of the Gila and Salt River Meridian, Arizona. Subtitle: Supplemental Plat.

Scale: Bar scale in chains, and bar scale in feet.

Memorandum:

This plat showing amended lottings created by the segregation of Mineral Survey No. 4180 in section 32, T. 9 N., R. 2 W., Gila and Salt River Meridian, Arizona, is based upon the plat

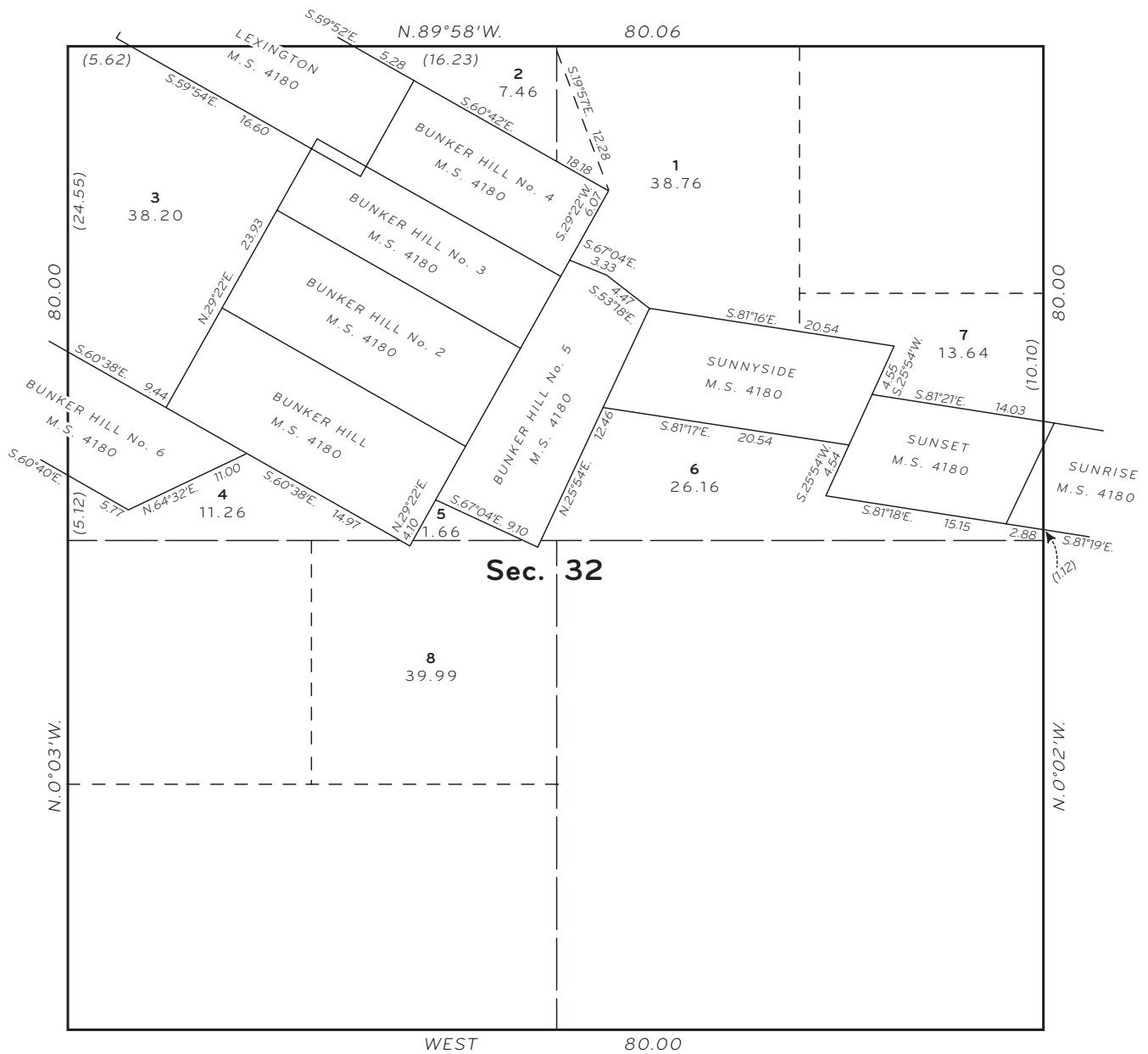


Figure 9-6. Supplemental plat with segregation of mineral claims.

approved May 14, 1920. Plat prepared by Bandy Roy, Cadastral Surveyor, beginning January 11, 2010, and completed February 11, 2010, pursuant to special instructions dated December 28, 2009, and approved January 4, 2010, and assignment instructions dated January 7, 2010, for Group No. 3070, Arizona.

Certificate: Heading similar to that shown on the specimen supplemental plat, appendix IV.

This plat, showing amended lottings, is based upon the official and office records and, having been correctly prepared in accordance with the

requirements of the law and the regulations of this Bureau, is hereby accepted.

For the Director

Chief Cadastral Surveyor for Arizona

**Plats of Mineral Surveys**

**9-103.** The following instructions relating especially to mineral plats should be observed. The returns of the survey when filed in the cadastral survey office are carefully examined and compared with the records to determine that all conflicts with prior approved surveys



are correctly shown, that all connecting lines given are in harmony with the record, that all material errors found in prior surveys are fully reported, and that the calculations of intersections and of conflicting areas are correct. The plat preparation and plat size is the same as for rectangular plats. The final plat is drawn on a scale of 200 feet to an inch when practicable. (See specimen mineral survey field notes and plat, appendix III.)

The scale should be large enough to illustrate clearly the improvements, conflicts, and physical features described in the field notes, together with all courses and distances of intersecting lines and connecting lines, where space permits. Any topographic features described in the field notes tending to confuse or obscure the plat may be omitted, but as the copy of the plat posted on the claim is a notice to the public of the ground applied for, all of the roads, streams, and other objects that may aid in locating the surveyed ground should be shown.

In case the entire survey cannot be shown on one sheet on a scale large enough to be clear, two or more sheets may be used and numbered consecutively, each sheet bearing the inscription "Survey No. \_\_\_\_\_, Sheet No. \_\_\_\_\_ of \_\_\_\_\_ Sheets." Each sheet should carry the certificate of acceptance.

**9-104.** The mineral survey is approved in the cadastral survey office. When approved, the plat is reproduced and the returns of the survey are distributed in accordance with existing regulations. (See sections 9-32 and 9-84 for reproduction and distribution of mineral survey returns.)

### Plats of Mineral Segregation Surveys

**9-105.** Plats of mineral segregation surveys are similar to supplemental plats that segregate patented mineral surveys but are based upon data obtained by a field survey rather than from examination and office records. All field data are shown and used in the computation of the amended lottings. See sections 9-32 and 9-84 for reproduction and distribution of mineral segregation survey returns. (See also sections 10-94 through 10-100.)

**9-106.** Such plats are also accepted by the Director, as indicated by the following examples.

Figure 9-7 illustrates:

Segregation of patented mineral claim, including a dependent resurvey of the section boundaries. Field work required to secure connecting line from the public land net to

the mineral monument and other data for the accurate showing of the new lots.

Title: Township 20 South, Range 10 East, of the Gila and Salt River Meridian, Arizona. Subtitle: Mineral Segregation.

Scale: Bar scale in chains, and bar scale in feet.

Memorandum:

Dependent resurvey of section 24 and survey of connecting line to U.S.M.M. No. 6 for segregation of the Lillie Lode of Mineral Survey No. 562, executed by Roger F. Wilson, Cadastral Surveyor, December 20 and 21, 2009, under Special Instructions dated August 29, 2009, for Group No. 1133, Arizona, to accommodate State grant AZA-129835.

East boundary surveyed by Lewis Wolfley, Deputy Surveyor, in 1885, and subdivision by G. J. Roskrige, Deputy Surveyor, in 1886, as shown on the plat approved March 27, 1888.

Certificate: Heading similar to that shown on the specimen mineral survey plat, appendix III.

This plat is strictly conformable to the approved field notes, and the survey, having been correctly executed in accordance with the requirements of law and the regulations of this Bureau, is hereby accepted.

For the Director

Chief Cadastral Surveyor for Arizona

**9-107.** Figure 9-8 illustrates:

Mineral segregation survey of an unsurveyed mineral claim, including a dependent resurvey of the section boundaries and the survey of connections to the mineral claim.

Title: Township 21 South, Range 70 West, of the \_\_\_\_\_ Meridian, (State). Subtitle: Mineral Segregation.

Scale: Bar scale in chains, and bar scale in feet.

Memorandum:

Mineral segregation survey of an unsurveyed mineral claim with connecting lines

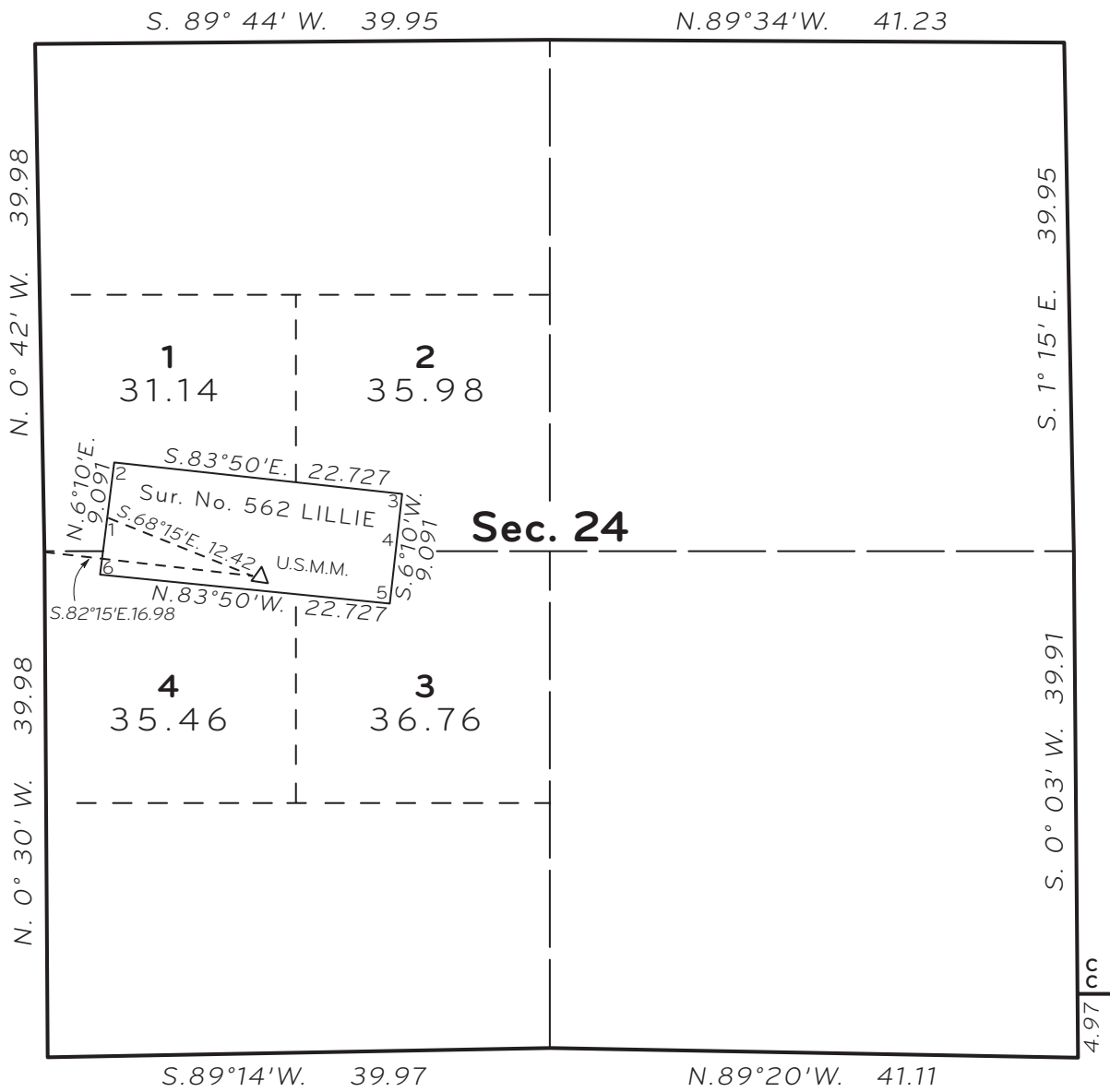


Figure 9-7. Segregation of a patented mineral lode claim.

and the incidental dependent resurvey of section 20, providing the basis for the segregation of the mineral claim, executed by John Smith, Cadastral Surveyor, October 7 to 12, 2009, inclusive, under Special Instructions dated September 14, 2009, for Group No. \_\_\_\_\_, (State), to accommodate Exchange (state and serialized case number).

Boundaries of section 20 surveyed by Albert W. Brewster, Deputy Surveyor, in 1879, as shown on the plat approved October 23, 1879.

Certificate: Heading similar to that shown on the specimen mineral survey plat, appendix III.

This plat is strictly conformable to the approved field notes, and the survey, having been correctly executed in accordance with the requirements of law and the regulations of this Bureau, is hereby accepted.

For the Director

Chief Cadastral Surveyor for (State)

**Plats of Fragmentary Surveys**

**9-108.** The term “fragmentary survey” is applied to surveys made to identify parts of townships and sections that were not completed in the first instance. This class includes partially surveyed sections; outlying

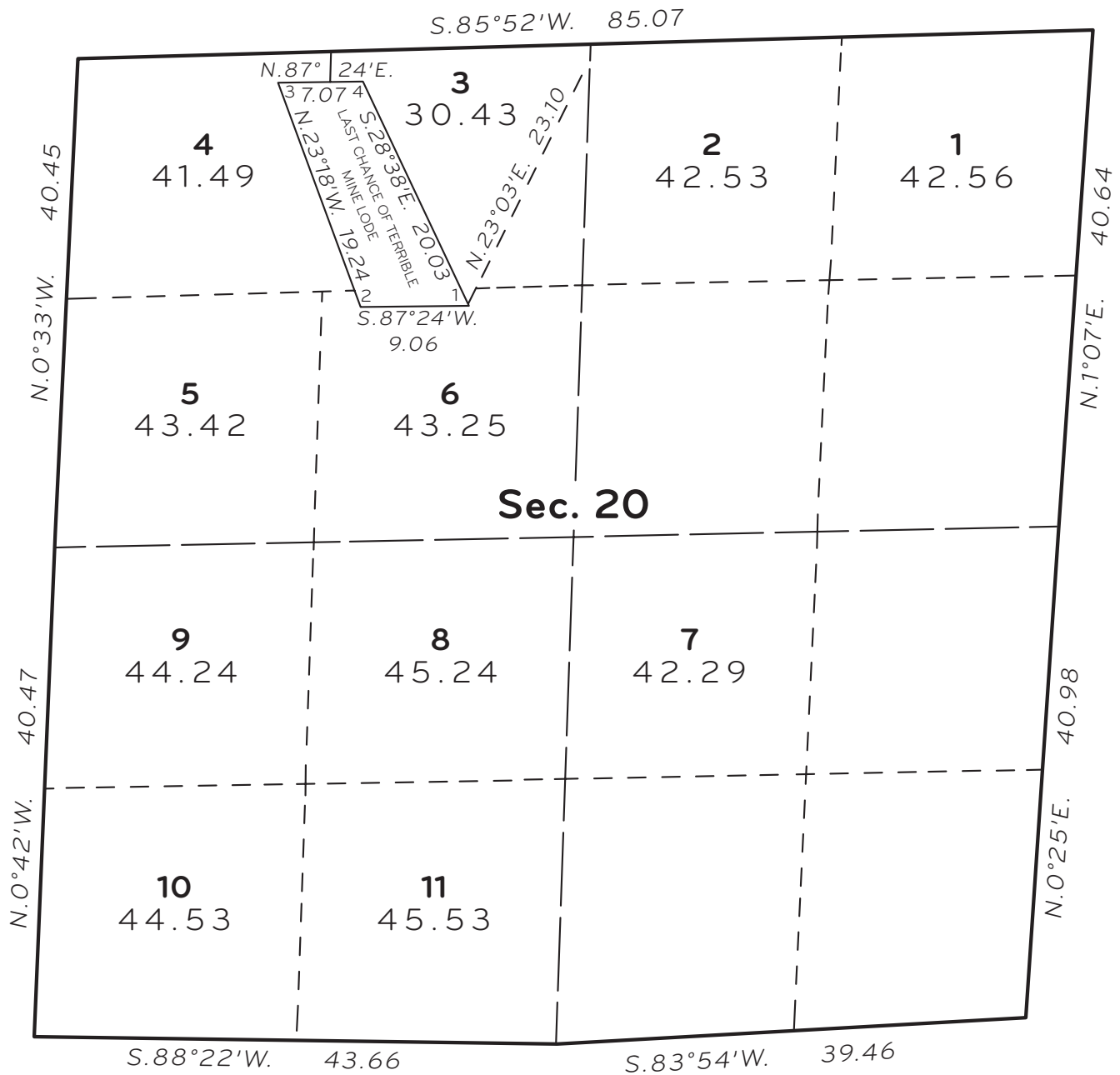


Figure 9-8. A mineral segregation survey.

areas protracted as surveyed sections; omitted or unsurveyed islands, if title is in the United States; such areas as lands in place at date of original subdivision situated between a grossly erroneous or fictitious meander line and the actual bank of a stream or lake, where riparian rights do not attach as under the usual doctrine; and other lands of substantial extent that for various reasons were not included in the original surveys.

These types of surveys frequently require consideration of the question of title involved preliminary to the extension of the former surveys.

In all such fragmentary surveys the new lottings are in addition to but without changing the former subdivisions if alienated.

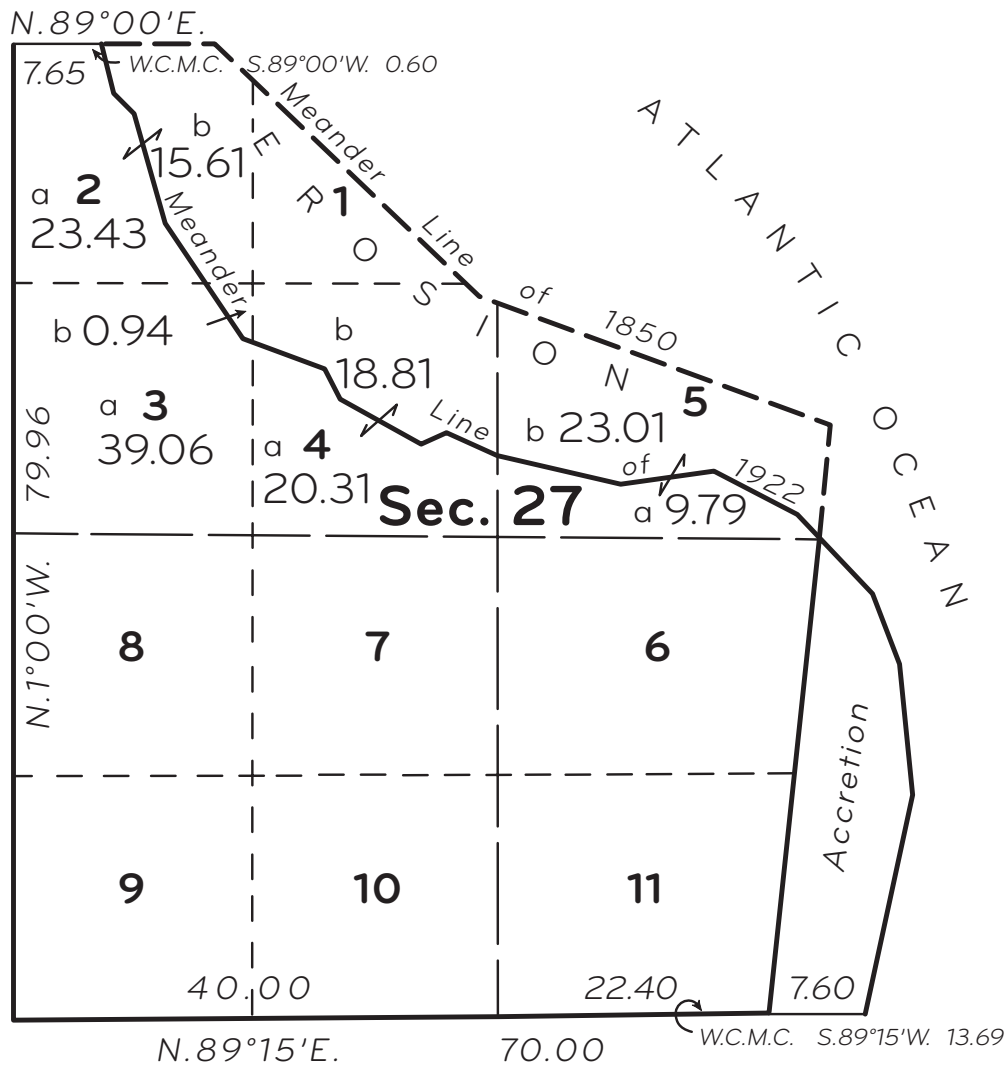
**9-109.** A notable exception to the principle that no changes should be made in the former lottings if alienated is found in those cases that involve retracements or dependent resurveys where *erosion* has occurred along the bank of a stream or lake or other body of water that substantially changes the configuration of the former lots, and where it may be desirable to show the quantity of land remaining and that destroyed. Similar problems

in platting are found in those cases of erroneous meandering where the record position of the original meander line is found to fall within the body of water. In these cases the former lot boundaries were situated within the water area and are indicated in light broken lines, and the quantities of each subdivision affected are shown in two parts; part "a" denoting land area and part "b" denoting water area. These areas are computed proportionately according to the amount shown for the original subdivision, the sum of "a" and "b" being made equal to the original total (figure 9-9). A memorandum to this effect should appear upon the plat. This procedure is applicable in showing the effect of the flooding of Federal interest lands by artificial impoundment (section 8-31).

**9-110.** All technical data in reference to the retracement, reestablishment and extension of the section boundaries

and connecting lines, and the complete topographical representation over the additional areas are shown upon the plats of fragmentary surveys. If the retracements and remonumentation assume the character of a dependent resurvey of the boundaries of one or more sections, that fact is indicated on the plat together with a proper showing of the important map data throughout the entire area surveyed and resurveyed. There is also shown an appropriate reference to the former approved plat or plats, and a citation of the authorization for the extension survey. The area statement includes separately the total areas surveyed and dependently resurveyed.

**9-111.** In some fragmentary surveys the main purpose of a retracement is (1) to ascertain the true location of previously established monuments, (2) to account for discrepancies in the directions and lengths of lines,



**Figure 9-9.** Irregular subdivisions as affected by erosion and accretion after survey, without introducing questions of riparian rights. The subdivisions affected are shown in two parts: "a" denoting land area and "b" denoting water area. A proportional adjustment is made in the computation of the quantities, if necessary, to make the sum of "a" and "b" equal to the original total.

(3) to reflect correct plat representation, and (4) to serve as a proper basis for the calculation of exact areas within the legal subdivisions where the methods customarily followed in the construction of a supplemental plat are inadequate (section 9-88). Where such field work is required, the data derived by the retracement is used for all purposes as in a dependent resurvey. Thus, where there are segregations to be made, the areas of the new lottings and other legal subdivisions are derived by exact calculation.

**9-112.** In some nonrectangular surveys (sections 10-32 through 10-39), not all of the directions and lengths of lines between monuments or between indicated corners of the subdivisions can be carried to the plat without an overburden at the scale, or it may be unnecessary to represent all such data. In these cases it may be noted on the plat that the data will be found in the field notes of the surveys.

In some cases where there are numerous and frequently very irregular lottings, it may be desirable to carry the complete data to the plat. The scale of the base drawing, and the required additional sheets is enlarged in these cases to accommodate the proper presentation of the data. Traverse lines may be shown by marginal tabulation.

Bearings and distances of meander lines should be shown in the field notes and may be depicted upon the plat.

**9-113.** The certificate of acceptance on plats of fragmentary surveys will take the usual form; the necessary memorandum should be modeled after the examples given for the special cases explained in chapter X.

### Plats of Protraction Diagrams

**9-114.** Protraction diagrams have been developed in two forms. Prior to 1998, corner positions were defined by bearing and distance with reference to the exterior boundary of the protraction. Subsequently, the process was amended and corner positions are now defined by coordinates, often called an amended protraction diagram.

The protraction diagrams should be constructed at a scale of 1 inch equals 40 chains. There should be a separate sheet for each township and an index drawing for each unit. It is not necessary to indicate scale on the index drawing. The existing survey lines should be shown as heavy-weight solid lines. Reliable protracted

lines should be shown as medium-weight long dashed lines. Protracted lines (designated bearing or random and true lines) should be shown as medium-weight short dashed lines. A legend on line weights should be put on each sheet. The six-digit Geographic Coordinate Data Base (GCDB) point identification scheme will be used to identify Plan of Survey Coordinates (POSC) section corners within the protraction and may be shown on the plat. Irregular POSC sections will be lotted in the same way sections are lotted in a survey, thereby defining how the excess or deficiency will be distributed (section 3-138).

The latitude and longitude may be shown in a table on the margin of the diagram which will reference the corners by their GCDB six-digit identifier (figure 9-10 and appendix V). The coordinates should be carried to four decimal places of a second and will be reported for POSC section corners and those corners of areas to be protected (i.e. existing withdrawals in protracted blocks).

**9-115.** The authority for the preparation of protraction diagrams issues only from the BLM Director. The specific purpose to be served and the details involved are included in the authorization signed by the Chief Cadastral Surveyor or request signed by the requesting official. In every instance the status of the surrounding subdivisions must be examined prior to authorization and care exercised that no changes are contemplated that will affect any adjoining alienated land. If field work or examinations of other records are necessary in order to prepare the diagram, the regular procedure outlined for executing a dependent resurvey will be followed. The administrative determination of the need for a protraction diagram rests with the appropriate Chief Cadastral Surveyor, subject to the diagram's acceptance for the BLM Director, and filing in the official survey records.

**9-116.** Upon the determination by the approving official of the requirement for a protraction diagram, special instructions giving the detailed specifications will be set out, prepared, signed, and approved. Assignment instructions will be issued. A survey group file will be created and contain the entire record of the protraction diagram process.

**9-117.** The protraction diagram official record will consist of a protraction diagram and the survey group file. Copies of the records used for the preparation of the protraction diagram are retained in the survey group file. The survey group file must contain corner description information, copies of local surveys, examination



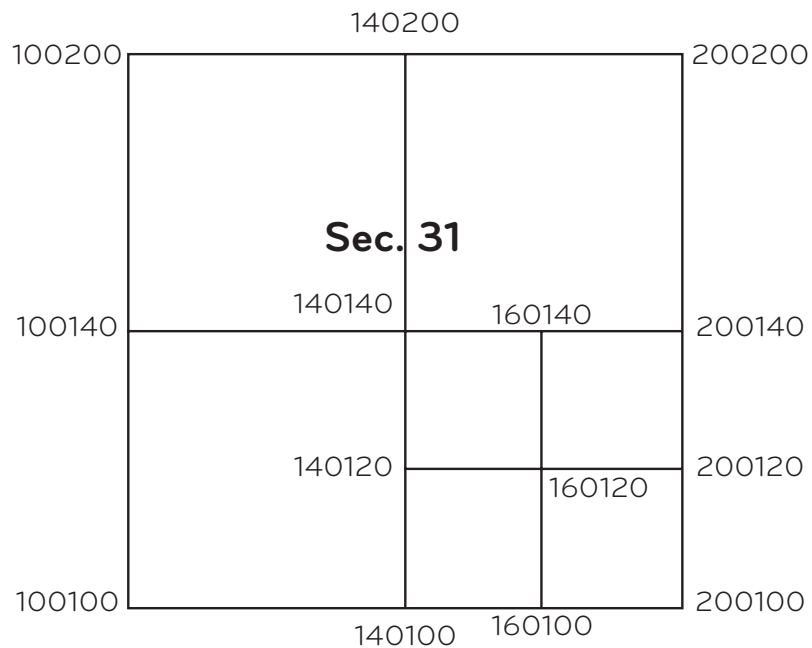
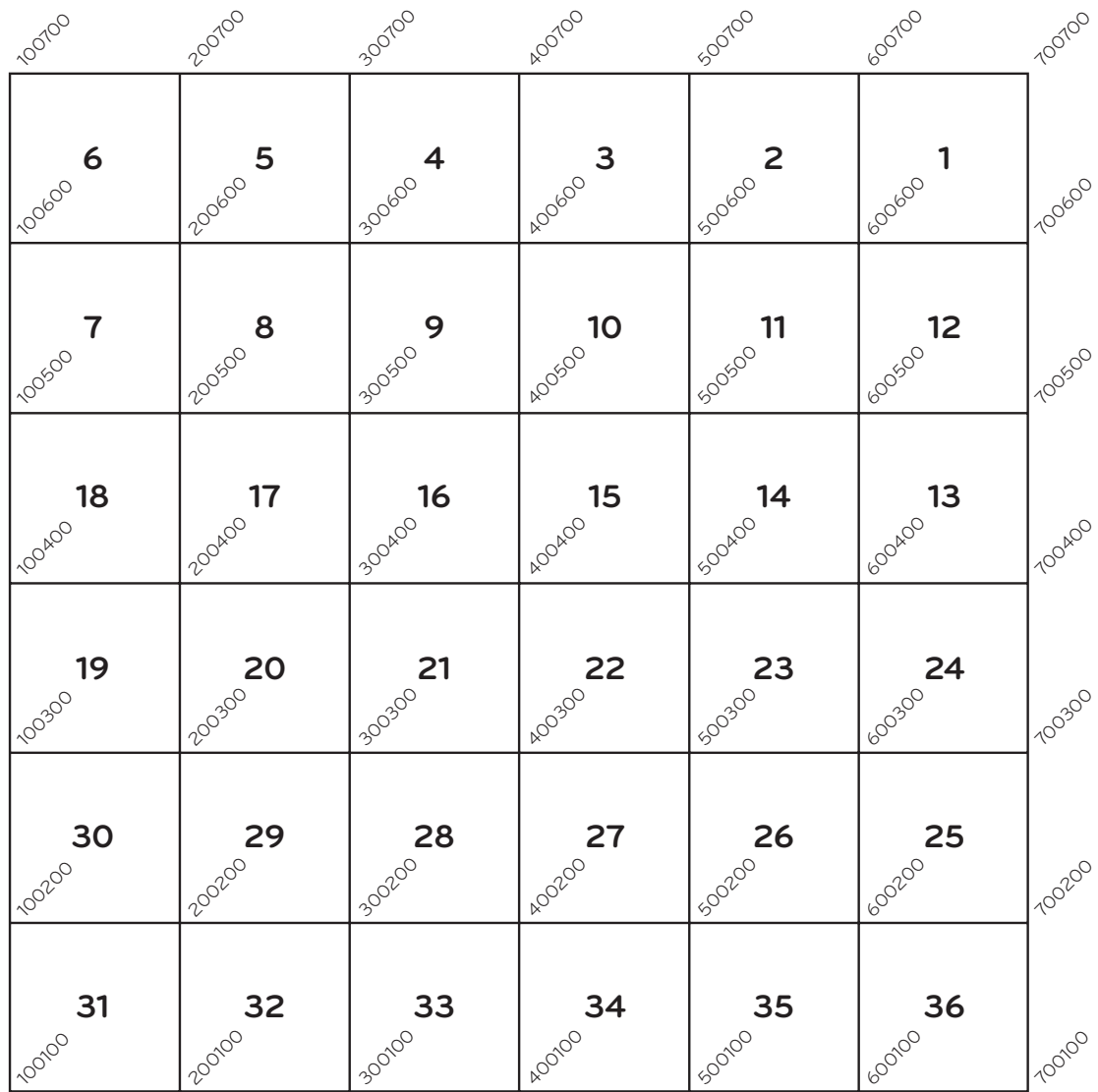


Figure 9-10. Primary corner identifier for GCDB.

reports, the authorization or request, special instructions, assignment instructions, and other relevant materials.

The survey group number, the dates of the authorization or request, special instructions, and assignment instructions, along with the beginning and completion dates will be placed on the diagram. The reproduction and distribution of protraction diagrams is described in section 9-84.

**9-118.** The certificate of acceptance follows the arrangement shown on the specimen plats, and the memoranda include the pertinent data involved in the preparation of the diagram.

### Resurvey Plats

**9-119.** A somewhat different type of plat is required for representing resurveys as defined in chapters V, VI, and VII. The identity of lands in which valid rights have been acquired based upon a prior subdivision must be preserved. The subdivision of the remaining Federal interest lands may or may not be modified, according to the type of resurvey.

### Requirements on Plats of Dependent Resurveys

**9-120.** In addition to the usual data, the plat should carry a marginal memorandum that qualifies the character of the dependent resurvey, also a reference to the previous plat (or plats) to which it is related.

For example, in case of a whole township completely dependently resurveyed, the following general statement is applicable:

This plat represents a dependent resurvey of the original township boundary and subdivisional lines designed to restore the corners in their true original locations according to the best available evidence.

Except as indicated hereon, the lottings and areas are as shown on the plat (or plats) approved \_\_\_\_\_ (date or dates) and officially filed \_\_\_\_\_ (date or dates).

If the original subdivisions were executed in two or more parts, or if the township has not been completely dependently resurveyed, the memorandum is modified.

The reference to modified lottings or revised areas is omitted when there are no exceptions.

A necessary additional citation takes the following form:

Survey executed by \_\_\_\_\_  
beginning \_\_\_\_\_, and completed  
\_\_\_\_\_, pursuant to Special  
Instructions for Group No. \_\_\_\_\_, (State),  
dated \_\_\_\_\_.

**9-121.** For notes on plat only returns, the desired historical references to (1) the field notes and plats of the earlier surveys, (2) lines more recently resurveyed that form a portion or portions of the plat outline, and (3) lines run and marked by county and other local surveyors found acceptable for the identification of tract boundaries, etc. will be elaborated upon as needed to clarify every feature of the resurvey incorporated in the marginal notation part of the plat.

**9-122.** On plats of dependent resurveys, the actual quantity of the areas of the resurveyed Federal interest subdivisions will be shown. The number of acres will be the same as the total shown on the original plat, except as modified lottings have been made or revised acreages for legal subdivisions have been shown in tabulated form on the plat. The total should reflect the actual amount of the increase or decrease.

**9-123.** In some cases, the question of a revision or modification rests upon the element of *quantity* or upon that of *distortion* or both.

For practical purposes, a variation of approximately 2.00 acres to the quarter-quarter section has been found advisable before making a revision in area. A new lot number and area are assigned to each Federal interest subdivision that is assigned a modified description. No total area within the section is shown. Alienated subdivisions cannot be assigned a modified description but a designation for administrative purposes only can be made (section 10-4). Lot numbers within a section must not be duplicated. Once an aliquot part has been modified to a lot, it should not be returned to an aliquot part.

**9-124.** An exception is sometimes made to the 2-acre minimum where it can be shown that more exact acreage is needed for proper management. The more exact acreage of a unit can be shown within the legal subdivision or in a tabulated index. When the former is used, a

new lot number is assigned. When an aliquot part legal subdivision is assigned a lot number it loses its aliquot characteristics and can only be subdivided by survey or supplemental plat.

When a more exact acreage of a unit is shown in a tabulated index, a new lot number is not assigned and the aliquot part legal subdivision retains aliquot characteristics. The plat will carry a marginal memorandum that the description listed in the tabulated index is intended to refer to precisely the same land as that which was previously identified by its original survey or description. Acreages will be tabulated to the 40 acre level or lower, depending on the need.

A tabulated index may not be advisable when a unit is grossly distorted in shape. In this case, when more exact acreage of a unit is required, lot numbers should be assigned.

The total number of Federal interest legal acres covered by a dependent resurvey, listed by section, will be shown as marginal data on the plat (specimen resurvey plat, appendix II).

**9-125.** When the legal subdivision of acquired land is identified by means of a different legal subdivision designation the plat will clearly indicate that the modified legal subdivision designation is intended to refer to precisely the same land as that which was previously identified by its original survey or description.

The following should be regarded as a general suggestion:

Lot 1, section 10, is intended to designate precisely the same land as that established as the NW $\frac{1}{4}$  NW $\frac{1}{4}$ , section 10, shown upon the plat approved \_\_\_\_\_ (date) and filed \_\_\_\_\_ (date).

Trust and restricted fee legal subdivisions should not be modified without consultation with affected parties.

### Requirements on Plats of Independent Resurveys

**9-126.** All claims should be accounted for on the plat of an independent resurvey as (1) segregated tracts, (2) conformed to the lines of the resurvey under their original description, or (3) under a modified description with outline indicated by heavy black lines. An exception to this rule is made where all the claims within a township have been conformed to the lines of the

dependent resurvey (section 5-65(5)) *under their original description*, in which event a statement should be made on the margin of the plat that:

All claims originally described as in this township are intended to conform to the lines of the dependent resurvey under their original description.

**9-127.** The additional memorandum that is placed on the plat of the independent resurvey is designed to clarify its very special and unusual character. It should especially show that a former record plat of approximately the same area has been superseded or cancelled by official action as the basis for the identification, administration, or disposal of the vacant or unappropriated Federal lands. Moreover, in protecting those rights as to location that may have been acquired based upon the superseded or cancelled plat, the locations of the alienated land are identified in accordance with the plat protraction and marks of that survey. The independent resurvey plat is identified as hereafter being the basis for the identification and description of the alienated land.

The following should be regarded as a general suggestion:

This plat represents a resurvey which is independent of and that supersedes, so far as the Federal interest lands are concerned (hereon indicated by new subdivisional lines, lottings, and areas), all such similar units that are shown upon the plat (or plats) approved \_\_\_\_\_ (date or dates) and filed \_\_\_\_\_ (date or dates).

All tract segregations shown hereon represent the position and form of claims under the original description as referred to the original survey, located on the ground according to the best available evidence of their true position and legal boundaries.

Where the boundaries of certain sections of the former survey have been restored as the best identification and form for protecting the alienated lands, and possibly including other sections of entirely Federal interest land with boundaries that have not been changed, the memorandum and historical citations take the forms that are outlined in section 9-130.

**9-128.** When a tract or a conformed claim described by a modified description is shown on an independent

resurvey plat, an amended description or correction of conveyance document should be issued. The land status records must be updated to show the identical geographic relationship of the former description under the original survey with the modified description under the resurvey. The public should be given constructive notice, and county officials where the lands are located should be given actual notice of the issuance of a modified description.

**9-129.** The memorandum in section 9-127 is modified if one or more of the claims shown on the land status diagram are conformed to the lines of the independent resurvey and described by different legal subdivision (section 5-65(5)), as follows:

All tract segregations shown hereon represent the position and form of said claims under the original description as referred to the original survey, located as such on the ground according to the best available evidence of their true position and legal boundaries. All other claims shown to conform to the lines of the independent resurvey, whether by the original or new legal subdivisions, represent the position and form of said claims under the original description as referred to the original survey, located as such on the ground according to the best available evidence of their true position and legal boundaries.

**9-130.** If the whole township has been independently resurveyed, and where the plat shows no sections with boundaries as a whole that have been restored by dependent methods, a memorandum to qualify the nature of the independent resurvey and the reference to the prior plat (or plats) may take the form that is given in section 9-127.

Where the boundaries of some of the sections have been restored by dependent resurvey methods and the remainder of the township has been subdivided on a new plan that is independent of the prior survey, the memoranda will be extended to make these facts clear, as for example:

This plat represents a resurvey that combines restored boundaries of certain sections with an entirely new subdivision of the remaining portions of the township as follows:

The boundaries and corners of sections \_\_\_\_\_,

\_\_\_\_\_, \_\_\_\_\_, etc., have been restored to their true original locations according to the best available evidence, and (excepting as new or modified Federal interest subdivisions are shown in these sections) the lottings and areas in said sections are as originally shown on the plat (or plats) approved \_\_\_\_\_ (date or dates) and filed \_\_\_\_\_ (date or dates).

The remainder of the township has been subdivided by the running of new lines and the marking of new corners, thereby superseding the former record lines and corners with reference to the Federal interest lands remaining undisposed of. The tracts identified hereon represent alienated parts of sections shown on the plat (or plats) approved \_\_\_\_\_ (date or dates) and filed \_\_\_\_\_ (date or dates).

The memoranda referred to in sections 9-126, 9-127, and 9-129 are supplied as appropriate.

A necessary additional citation takes the following form:

Survey executed by \_\_\_\_\_, beginning \_\_\_\_\_, and completed \_\_\_\_\_, pursuant to Special Instructions for Group No. \_\_\_\_\_, (State), dated \_\_\_\_\_.

**9-131.** Important items of topography and valuable permanent improvements are shown along the lines of the tract survey. It is impossible, at the usual scale, to show objects of little relative importance.

**9-132.** The requirements for showing the positions of alienated lands on the plats of independent resurveys are given in the memorandum forms, which appear in sections 9-126, 9-127, and 9-129. The following sections show how the identification is accomplished in the cases of both tract segregations and conformed claims.

**9-133.** Tract segregations are laid out on the plats of resurveys as any private land claim are shown upon an original plat. In order to show the detail of complicated situations one or more additional sheets are frequently necessary. If a claim is found to be conformable as defined in section 5-65(5), the claim boundaries may be shown by giving greater weight to such parts of the regular subdivision-of-section lines of the

independent resurvey plat. The outline of each tract segregation is shown on the first or principal sheet on the plan usually employed to show other types of private land claims.

**9-134.** On any of the several sheets, as appropriate, an index is supplied to tabulate the description of each tract in terms of the original plat. The index form shown in table 9-9 is acceptable.

**9-135.** In some cases there is a demand for the description of a tract in terms of its component parts as determined by the original survey. In these exceptional cases, and only as appropriate, the several parts may be indicated by letters A, B, C, etc. (figure 9-13), with the index modified as shown in table 9-10.

**9-136.** The above method is well adapted to the identification and subdivision of isolated tracts of Federal interest lands where said lands have been surveyed as

tracts. In these cases the arrangement of the data carried by the index is the same, and the status of the Federal tract is shown as vacant.

**9-137.** If there are one or more conformed claims to be identified by amended description or correction of conveyance document in terms of the independent resurvey, without segregation by tracts, another form of index is required, as shown in table 9-11.

**9-138.** The several forms of index may be combined into one tabulation and titled *Index to tabulate segregated tracts and appropriate subdivisions*. The bracket for “component parts” may be filled in only as needed. Tract segregations are required where modified descriptions embrace subdivisions that are smaller than the regular 40-acre unit.

**9-139.** The special requirements for lotting irregular parts of sections invaded by tract segregations are set

**Table 9-9.** Index to tabulate segregated tracts under their original legal subdivision descriptions.

No.	Tract		Original Survey		
	Entry and Status	Tp.	Rg.	Sec.	Subdvn.
39	Buffalo 2979	58	75	29	NW $\frac{1}{4}$ NW $\frac{1}{4}$
	H.E.	58	75	29	S $\frac{1}{2}$ NW $\frac{1}{4}$
	W.J. Williams	58	75	29	NW $\frac{1}{4}$ SW $\frac{1}{4}$
	Patented				
41	Buffalo 1567	58	75	20	SE $\frac{1}{4}$ SW $\frac{1}{4}$
	D. L. E.	58	75	20	W $\frac{1}{2}$ SE $\frac{1}{4}$
	W.J. Williams	58	75	29	NE $\frac{1}{4}$ NW $\frac{1}{4}$
	Pending				
77	Designated School Section	58	75	36	All
95	Sundance 03186	58	74	30	Lot 1
	D. L. E.	58	74	30	Lot 2
	C.R. Massey				
	Final certificate				
101	Vacant	58	75	24	Lot 4
102	Vacant	58	75	23	NE $\frac{1}{4}$ SE $\frac{1}{4}$

**Table 9-10.** Index to tabulate component parts of segregated tracts under their original legal subdivision descriptions.

No.	Tract		Original Survey			Component Parts	
	Entry and Status	Tp.	Rg.	Sec.	Subdvn.	Sub-Tract	Area
42	Buffalo 0833	58	75	20	NE $\frac{1}{4}$ SE $\frac{1}{4}$	B	40.00
	H.E.	58	75	21	Lot 4	A	32.00
	Thomas R. Williams	58	75	21	NW $\frac{1}{4}$ SW $\frac{1}{4}$	C	40.00
	Pending	58	75	21	SW $\frac{1}{4}$ SW $\frac{1}{4}$	D	40.00
46	Buffalo 08642	58	75	24	Lot 3	A	28.12
	H.E.	58	75	24	NW $\frac{1}{4}$ SW $\frac{1}{4}$	B	40.00
	Emmet Cain	58	75	24	NE $\frac{1}{4}$ SW $\frac{1}{4}$	C	40.00
	Pending	58	75	24	SE $\frac{1}{4}$ SW $\frac{1}{4}$	D	40.00



Table 9-11. Index to tabulate conformed claims under modified legal subdivision descriptions.

Independent Resurvey				Conformed Claim	Original Survey			
Tp.	Rg.	Sec.	Subdvn.	Entry and Status	Tp.	Rg.	Sec.	Subdvn.
45	79	12	SW¼SE¼	Buffalo 984	45	79	12	NE¼SE¼
45	79	12	SE¼SW¼	T. & S.	45	79	12	NW¼SE¼
45	79	12	SW¼SW¼	Fred A. Jones	45	79	12	NE¼SW¼
				Pending				
45	79	13	NW¼NE¼	Buffalo	45	79	12	SE¼SE¼
				S. S. List 6				
				Approved				

out in sections 5-70 through 5-72, and are illustrated by figures 9-11, 9-12, and 9-13.

**9-140.** Occasionally there is need for denoting the several parts of a tract in terms of quarter-quarter sections and lots of the independent resurvey (figure 9-13). This may be accomplished by protraction, showing lot numbers and areas as determined by the independent resurvey. The lottings within the tract should be made to complete the adjoining irregular quarter-quarter sections of the independent resurvey. This type of lotting requires no change in the index.

**9-141.** Where a tract is subdivided (figure 9-13), and (1) if it is essential to perpetuate the units of the original survey, then the lines of the original quarter-quarter sections are shown; but (2) in those cases of relinquishment or cancellation and it is probable that any new entry will be coupled with adjoining lottings by the independent resurvey, then a lotting within the segregated tract as determined by the section boundaries of the independent resurvey should be adopted. In the great majority of cases the patent eventually issues in accordance with the original entry or selection, and the necessity for the subdivision of segregated tracts is exceptional. If it is necessary to subdivide a tract on the resurvey plat, the method should be based upon the type of disposal and the purpose to be served. Where such necessity is not clearly apparent, no subdivision should be made, but a supplemental plat may be prepared at a later date to meet specific requirements.

**9-142.** If there are overlapping claims as defined in section 5-65(6), the conflict is indicated on the plat of the resurvey. No new lot numbers should be assigned nor quantities shown within the segregated tracts that are involved in the conflict (figure 9-12). The showing of the component parts must follow the construction of a supplemental plat. In these cases, the plat will carry a reference to a subsequent supplemental plat to be prepared

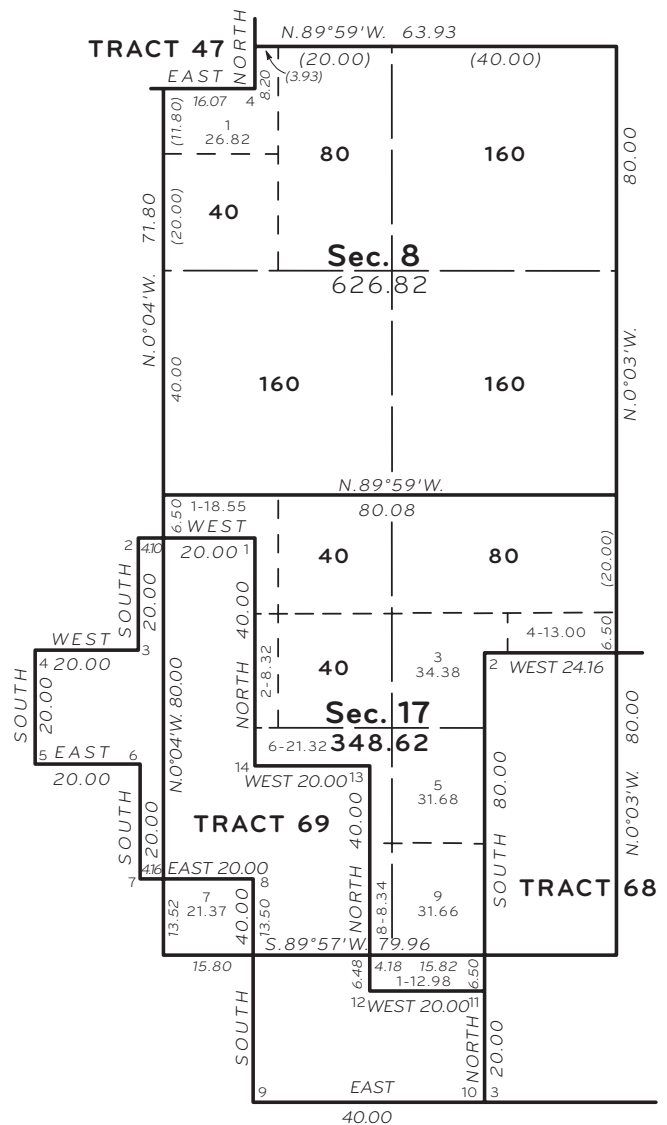


Figure 9-11. Normal tract segregations, with lotting of the adjoining Federal interest land. The tract segregations are laid out on the plat as any private land claim would be shown on an original plat.



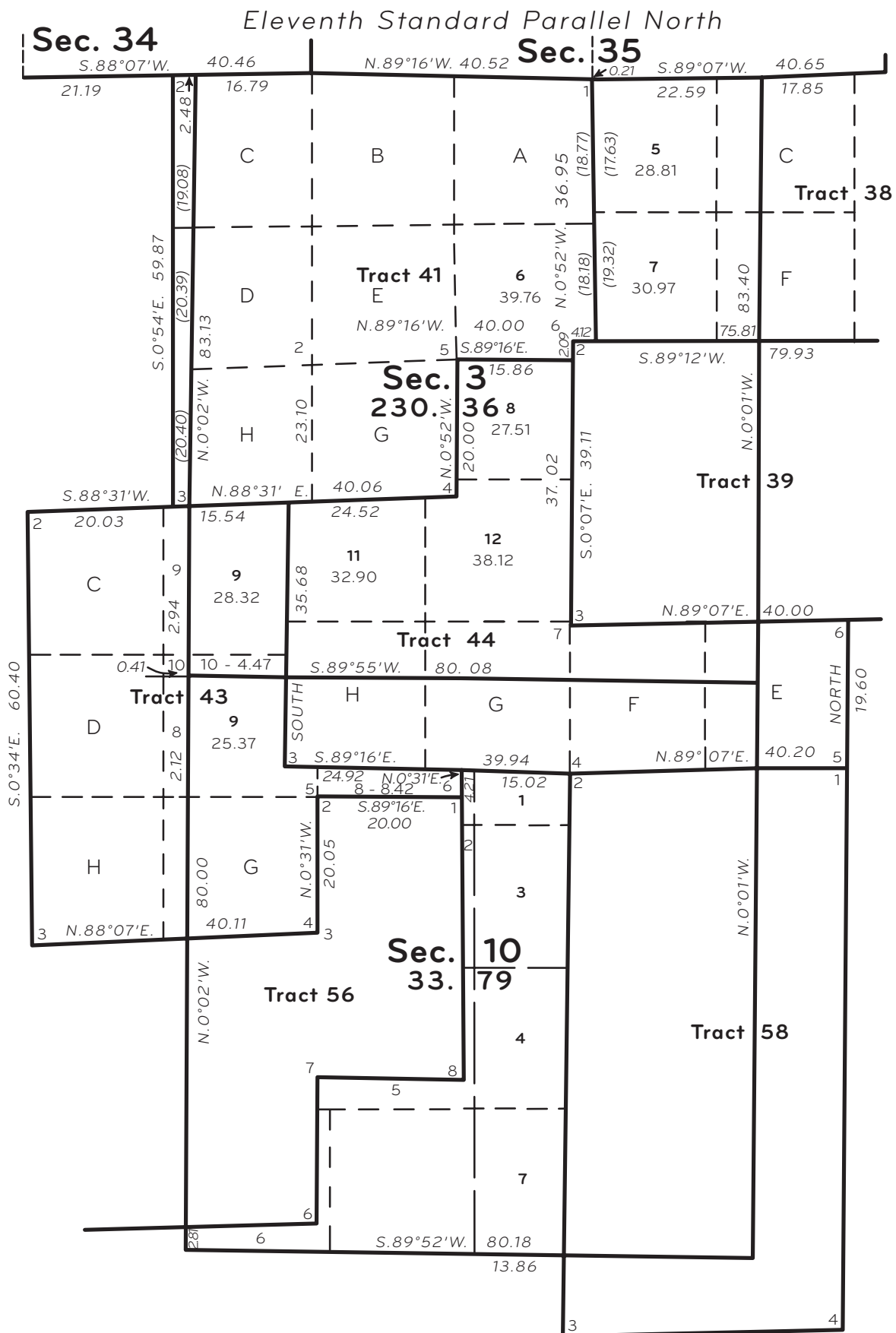


Figure 9-13. Supplemental plat issued subsequent to the adjudication of the rights involved within a conflict (figure 9-12), with revised form of conflict-free lotting (table 9-12).

after the adjudication of the rights involved within the conflict, with a revised form of conflict-free lotting.

A memorandum is added to the index as follows: *See field notes for area of any part of a tract in conflict with another tract.* The uninvolved Federal interest land outside of the segregated tracts is lotted regularly except that the description of any subdivision of the original survey embraced in a tract or conformed claim under modified description is not repeated on the resurvey plat; instead it is assigned an appropriate lot number.

**9-143.** No memorandum or other declaration should be shown upon a plat of a resurvey that can be construed as an adjudication of a settlement right, entry, or State selection or right under any grant *as to status* nor as an adjudication of a conflict, excepting as appropriate action on the case may have been taken prior to the date of the filing of the survey plat.

**9-144.** The usual technical data in reference to the direction and lengths of lines are arranged on the several sheets as may be appropriate. The fractional distances along the section lines, the record intersections of the lines of the independent resurvey with the lines of claims, and the connections to the angle points of the tract surveys are shown in such a manner as to indicate the values used in computing areas of the Federal interest land subdivisions. The complete topographical representation is carried by the first or principal sheet. The section numbers are carried on all of the sheets. The first or principal sheet carries a memorandum of the total number of sheets in the series. The sheets are numbered consecutively in the upper right corner, thus: "Sheet 1 of 7 Sheets," "Sheet 3 of 5 Sheets," etc.

**9-145.** On plats of independent resurveys, the lot numbers and areas within the sections that are invaded by nonconformable tract segregations are usually shown on the additional sheets, where such sheets are required. Otherwise, the lot numbers and areas are shown on the first or principal sheet.

**9-146.** The total area shown within each independently resurveyed section indicates the sum of the several parts that are hereafter to be identified by exclusive reference to the resurvey plat. In the total area statement to be supplied on the plat of an independent resurvey, the acreage is shown in three parts: (1) Total area of segregations; (2) Total area exclusive of segregations; and (3) Total area resurveyed. If a tract overlaps a township boundary, only the part within the township is counted in this total. If there are conflicts, the area in conflict is counted once only.

**9-147.** The first or principal sheet of the plat carries an appropriate memorandum of the authority upon which the resurvey was made. All of the sheets show the usual form of certification of acceptance.

**9-148.** A supplemental plat must be prepared after the adjudication of the rights involved within a conflict when required to facilitate an amendment of entry or patent or correction of conveyance document. On the supplemental plat, component parts that are free of conflict are protracted and designated as shown on figure 9-13. Lot numbers are assigned to the modified component parts of each adjudicated tract, serially within the sections of the resurvey, and areas shown, to afford descriptions that are conflict free. In these cases, the supplemental plat should have a revised index to the segregated tracts shown and a reference to the preceding plat. In the index all subdivisions in terms of the original survey are listed, but no sub-tracts are assigned to any subdivision that is reduced by the elimination of previous conflicts. The appropriate section numbers, lot numbers, and areas of the reduced tract subdivisions that are conflict free are listed in the columns of independent resurvey descriptions and areas of component parts. A footnote will follow the index referring to each new lot indicating the lot is a portion of the original subdivision free of conflict.

**9-149.** The usual rules of field procedure are observed in the protraction of the tract subdivisions. Where adequate control is shown in the record, the original sections are subdivided regularly. However, if tracts have been segregated by the independent resurvey with limited control, the points for intermediate sixteenth-section, quarter-section, and section corners on the original tract boundaries are determined by proportionate intervals between the established angle points, and the interior lines are drawn to connect corresponding points on the opposite sides of the tract boundaries, fixing the corners of each component part by intersections. The computed areas are based upon the data derived in the resurvey.

**9-150.** Table 9-12 is a revised index conforming to figure 9-13.

**9-151.** Not all independent resurvey plats can be treated similarly. Methods suited to situations not involved in a particular case should be set aside to avoid the introduction of unnecessary complications. The normal independent resurvey may be brought within a fairly definite, standardized drafting practice, but each unusual case needs a special analysis as to how the detail may be most suitably plated.

Table 9-12.

No.	Tract	Original Survey				Component Parts†		Independent Resurvey				
		Entry and Status	Tp.	Rg.	Sec.	Subdvn.	Sub-Tract	Area	Tp.	Rg.	Sec.	Subdvn.
38	Buffalo 010118	44	80	1	Lot 4	A	35.16					
	H.E.	44	80	2	Lot 1	B	35.86					
	Ralph R. Baldwin	44	80	2	Lot 2	C	36.06					
	Pending		44	80	2	SW¼NE¼	D	40.00				
			44	80	2	SE¼NE¼	E	40.00				
			44	80	1	SW¼NW¼	F	40.00				
			44	80	2	Lot 3		28.81	44	80	3	Lot 5 *
		44	80	2	SE¼NW¼		30.97	44	80	3	Lot 7 *	
41	Buffalo 09311	44	80	3	Lot 1	A	36.66					
	H.E.	44	80	3	Lot 2	B	36.85					
	Henry J. Brunning		44	80	3	Lot 3	C	37.00				
			44	80	3	SE¼NW¼	D	40.00				
	Pending		44	80	3	SW¼NE¼	E	40.00				
			44	80	3	NW¼SE¼	F	40.00				
			44	80	3	NE¼SW¼	G	40.00				
			44	80	3	SE¼NW¼		39.76	44	80	3	Lot 6 *
43	Buffalo 011734	44	80	3	SW¼SW¼	A	40.00					
	H.E.	44	80	10	NW¼NW¼	B	40.00					
	Perry Barnes	44	80	10	SE¼NW¼	C	40.00					
	Pending		44	80	10	SW¼NW¼	D	40.00				
								{28.32	44	80	3	Lot 9 *
			44	80	3	SE¼SW¼		{ 2.94	44	80	4	Lot 9 *
								{ 4.47	44	80	3	Lot 10 *
								{ 0.41	44	80	4	Lot 10 *
			44	80	10	NE¼NW¼						
								{ 2.12	44	80	9	Lot 8 *
								{25.37	44	80	10	Lot 9 *
			44	80	10	NW¼NE¼		8.42	44	80	10	Lot 8 *
			44	80	3	SW¼SE¼		*0.00				
44	Buffalo 07532	44	80	11	NW¼NE¼	A	40.00					
	H.E.	44	80	11	NE¼NW¼	B	40.00					
	Antoine Faure	44	80	11	NW¼NW¼	C	40.00					
	Pending		44	80	10	NE¼NE¼	D	40.00				
			44	80	2	NW¼SW¼		27.51	44	80	3	Lot 8 *
			44	80	3	SE¼SE¼		32.90	44	80	3	Lot 11 *
			44	80	2	SW¼SW¼		38.12	44	80	3	Lot 12 *
			44	80	3	NE¼SE¼		*0.00				

† See section 9-135.

\* Portion of original subdivision that is free of conflict.



## Chapter X

# Special Surveys and Mineral Surveys



## Special Surveys

**10-1.** Special surveys are surveys that involve unusual applications of or departures from the rectangular system. They often carry out the provisions of a special legislative act. A particular category of special surveys focuses on various types of water boundaries. In some cases, the special instructions merely expand the methods outlined in chapter III. In the more complicated special surveys, the methods must be carefully detailed.

The following discussion illustrates what is to be emphasized in the special instructions for each type of special survey.

### Tracts, Lots, and Parcels

**10-2.** Special surveys may involve areas of land that are not aliquot parts of sections but are designated as tracts, lots, or parcels. In common usage, the term “tract” is applied to an expanse of land of no particular size, often irregular in form. In modern Federal land surveys, the term is used specifically to mean an expanse of land that lies in more than one section or that cannot be identified in whole as a part of a particular section. It is properly described by tract number and township. Tracts within a township are numbered beginning with 37 or the next highest unused numerical designation to avoid confusion with section numbers. Tracts that have been segregated in the course of an independent resurvey are treated as described under that subject.

**10-3.** A “lot” is an irregular expanse of land with a Federal interest lying entirely within a surveyed section. Small expanses of land, when not aliquot parts of sections, are designated as lots wherever they can be identified as parts of a section. The description is by lot, section, and township.

**10-4.** A “parcel” is a special designation used for identification of an expanse of land. Parcels may include land with no Federal interest and should be so designated

except in independent resurveys, or if the proper name is “Tract \_\_\_\_.” To distinguish among several parcels, they may be called “Parcel A,” “Parcel B,” and so on. The Bureau of Land Management (BLM) does not modify land descriptions of alienated lands. The designation of alienated land as a parcel is for administrative purposes only and as a reference to the existing land description of the parcel. It does not change the chain of title.

### Subdivision of Sections—Special Cases

**10-5.** The need for subdivision of sections and any unusual methods required are brought out in the special instructions. Examples are Indian allotment surveys, subdivisions within reclamation projects, the determination of boundaries between intermingled Federal interest and patented lands within a section, and various fragmentary surveys needed to mark the boundaries of the remaining Federal interest lands. In complicated cases, particularly fractional sections, the subdivision of sections may be advisable to avoid the possibility of an incorrect local survey or in lieu of remonumentation of disputed section or quarter-section corner positions affecting Federal interest lands (see sections 3-99 through 3-137).

**10-6.** Nearly always the subdivision-of-section lines are run and marked in accordance with the showing of the official plat. An uncommon exception is when a disposal has been made of an expanse of land whose description clearly differs from the lottings or aliquot parts represented on the plat.

**10-7.** The customary lottings are often not shown on plats of very old surveys. A determination of what the disposals were intended to convey can then be made only by reference to the record of the disposals themselves. The record will more frequently show a disposal by aliquot parts, except within fractional sections, but often without the usual complement of quarter-section corners regularly established. An inquiry into the assigned areas in the record of the disposals should clarify the intended disposals.

Furthermore, in some of the old surveys quarter-section corners were not established on all true lines of the survey. Instead, the record shows that “half-mile” points were marked on the random line and not corrected to the true line midpoints. All such unusual problems should be brought out in the special instructions, as the diversity of the questions arising and the limited applicability of the answers precludes extended Manual treatment (see section 7-36).

**10-8.** Where special methods are unavoidable, they should be made to conform as nearly as may be practicable with the rules for the subdivision of sections discussed in sections 3-99, 3-100, and 3-112 through 3-137. The special instructions should specify the procedure when the areas do not conform to the rectangular system of surveys.

**10-9.** If a section is subdivided, the center quarter-section corner is established and monumented. If a quarter section is subdivided, all sixteenth-section corners are established and monumented. When requested or where impracticable, the established controlling sixteenth-section corners that are not located on the boundary of Federal interest land may not be monumented. Corners of lower order are established and monumented where necessary to mark the actual boundaries of Federal interest land within the minor subdivisions involved. Only the required boundaries need be surveyed within the sixteenth section, but, if this method is used, such lines must be connected to and balanced between corners on the sixteenth-section lines.

**10-10.** Figure 10-1 illustrates the type of plat showing the subdivision of sections. This includes a dependent resurvey of the section lines and the Indian reservation boundary, followed by the subdivision of sections as needed for administrative purposes.

### Indian Allotment Surveys

**10-11.** Indian reservation surveys should not be confused with Indian allotment surveys. Reservations and allotments are not the same. A reservation is a territorially and jurisdictionally distinct entity created by treaty, Federal purchase, Executive order or act of Congress. An allotment is a single expanse of land created from reservation land or off-reservation land and usually titled to an individual Indian.

**10-12.** Under the general and special allotment acts it has sometimes been the practice to make awards in units of less than the usual quarter-quarter section.

The appropriate act to be employed and the configuration and extent of the subdivision should be provided in the special instructions. The Bureau of Indian Affairs (BIA) is expected to advise upon the allotment process, including surveys conducted by the United States Indian Service (USIS).

**10-13.** When a proposed allotment or an existing allotment with a Federal interest is described by metes-and-bounds or by another nonrectangular description, or in some way definitely not correlated with a section line and/or statutory subdivision-of-section line, the allotment is assigned a lot number within each of the one or more sections involved. The lot numbers are independent of the serial allotment numbers. When an allotment is not conformable to aliquot parts and is located within two adjacent sections it may be assigned a tract number.

**10-14.** When executing a dependent resurvey of allotted lands that are described according to an official plat, the surveyor shall protect the plat; in other words, subdivide the section consistent with the method previously used. This is simplified when the survey field notes and plats are filed in the official survey records. See section 10-21 for further instructions if the allotment surveys were not filed in the official records.

### Subdivision of Section—Statutory Method

**10-15.** Generally, the awarded allotments conform to aliquot parts of a section where the boundary lines are located by connecting opposite corresponding corners placed as nearly as possible equidistant from two corners that stand on the same line. When this is evidenced by the record, the allotment boundaries have been run in accordance with the rules for the “statutory method” of subdivision of sections and quarter sections prescribed by 43 U.S.C. 752 and 753.

All regular subdivision corners, when located by the statutory method of section subdivision, are marked in the usual manner. When requested, the letter A (for allotment) is added and the serial allotment number, in each of the several quadrants, as appropriate. Allotment numbers are employed serially with the various Indian tribes or families, assigned by the BIA, when making an award of tribal lands. The plat may include a tabulated index outlining lot numbers, aliquot part descriptions, and serial allotment numbers. Status diagrams that show the Indian allotment awards should always be furnished with the special instructions.



### *Subdivision of Section—Three-Mile Method*

**10-16.** Surveyors working with Indian lands, on- or off-reservation, or lands that were Indian lands at the time of the survey or allotment must be aware of the “three-mile method” of section subdivision. Sometimes these sections are located in areas that are not near current Indian lands. Surveyors should always review the land’s survey and title history to identify Indian lands to determine those instances when the three-mile method might have been used. The three-mile method was used by the General Land Office (GLO) and the USIS, now the BIA, in subdividing sections. The record of those surveys indicates the methods used. This method is different from the statutory method of section subdivision. Both can create aliquot part descriptions, but each is identified by a different set of specified corner and boundary line location characteristics. The three-mile method creates specified corner and boundary line location characteristics that are determined from the survey evidence. Reading the title document only will not determine the method by which the section was subdivided into aliquot part descriptions. Problems arise when an aliquot part description based upon the three-mile method of section subdivision is attempted to be located according to the statutory method of section subdivision.

**10-17.** The “three-mile method” actually encompasses a variety of systems of section subdivision used to expedite the allotment of Indian reservations. There is no single three-mile method. The evidence, field conditions, and historical documents of the section subdivision must be carefully examined to determine which method was used. In some cases the section subdivision method can be found in special instructions for the survey, or in the Annual Instructions or Annual Reports issued by the Commissioners of Indian Affairs and GLO.

**10-18.** In its simplest and most common form, three-mile method sections were subdivided by establishing the north and south one-sixteenth section corners on the east and west boundaries of the section at midpoint between the quarter corners and section corners. The one-sixteenth section corners were sometimes called “ $\frac{1}{8}$ ” corners because by connecting them the section could be protracted into eight units, for 80-acre allotments.

The section would then be subdivided by running random and true lines from the south one-sixteenth section corner on one section line to the south one-sixteenth section corner on the opposite section line, then from the quarter corner on one section line to the quarter corner on the opposite section line, and from the north

one-sixteenth section corner on one section line to the north one-sixteenth section corner on the opposite section line. The section interior corners, including the “center quarter,” were established on the lines at equidistant positions east and west.

One-sixteenth section corners and, if required, one-sixty-fourth section corners (sometimes called “ $\frac{1}{32}$ ” corners because by connecting them with lines running north and south, the section would be divided into 32 units of 20-acre allotments) on the north and south boundaries of the section were established in a similar manner, i.e., at equidistant positions between the quarter and section corners. This method of section exterior corner placement was consistent with the statutory method.

**10-19.** The 80-acre and 40-acre allotments were often not assigned lot numbers on the survey plat, but returned as aliquot parts. The 20-acre allotments were generally returned as lots and numbered 1 to 32. For sections against the north and west boundaries of the township the excess or deficiency in distance would be placed in the last segment abutting the north or west boundary.

**10-20.** Variations of this basic system were used in different surveying districts. Unless the section is a perfect square, with all quarter section corners exactly at midpoint and on line between section corners, the aliquot part subdivisions by the three-mile method will be in a position different from the aliquot part subdivisions by the statutory method.

Because no single method was employed, each section must be dealt with on an individual basis. Within some sections, portions of lines were surveyed, north-south lines were surveyed, or centerlines of sections were surveyed by the statutory method and then the quarter sections subdivided by the three-mile method.

The surveyor must always study the survey plat and field notes thoroughly to determine how the allotments were surveyed. When dependently resurveying an allotment, patented by either an Indian trust or fee patent, where the official survey used the three-mile method, the surveyor must perform a dependent resurvey according to the official survey record. Recovered original corners shall stand as the corners of the patented lands and shall control the boundaries within the section regardless of how well the position fits the original plat position or the statutory method of subdividing a section.

If any of the original corners are lost, they must be restored using the appropriate method of proportionate measurement. Generally this is single proportionate



measurement. Corner restoration and further section subdivision must be conducted so as to “protect the plat.”

### *Indian Allotments and United States Indian Service Surveys*

**10-21.** Allotment surveys were also made subsequent to the original survey by the GLO and by the USIS. The USIS surveys were executed under an assumed survey authority read into the various Indian allotment acts, the general management responsibilities of the Commissioner of Indian Affairs, or as a duty assigned by the Secretary of the Interior in the exercise of his obligations under a special act.

**10-22.** Generally USIS surveys preceded the awarded allotments and conformed to the statutory method of subdivision of sections and quarter sections prescribed by 43 U.S.C. 752 and 753. Plats or field notes are not known to exist for some of the USIS surveys monumented on the ground. It was the practice of the USIS officials to walk the allottee to each corner to ensure that the allottee understood where the allotment was located.

How the subdivision of a section was surveyed cannot be determined from reading the conveyance document only. Often a section was subdivided by USIS using a three-mile method in the field subsequent to the GLO survey. The USIS surveys were (1) not approved as official surveys of the United States, and (2) not filed with the official Federal survey records. The GLO issued Indian trust and Indian fee patents describing the land by aliquot part subdivisions based upon the GLO official survey plat showing protracted aliquot part subdivisions by the statutory method. The result is a latent ambiguity between subdivision-of-section monuments and the conveyance document.

The USIS allotment surveys and monuments are generally accepted as marking the corners of the patent for which they were established when there is substantial evidence that was the Government’s intent. This intent is evidenced in several ways, including but not limited to (1) the allottee was shown the monuments by an Indian Service official, (2) conformance to the USIS survey record, (3) conformance to the USIS/BIA Allotment Book, (4) conformance to Annual Instructions or Annual Reports issued by Departmental officials, or (5) years of undisputed use and occupancy to USIS located positions.

**10-23.** In cases where the USIS allotment survey was subsequent to the GLO survey of the township and not

filed in the official records of the United States, the corners are not “original” corners of the GLO survey. The USIS surveys are thus akin to an administrative survey by the Government for its own purposes. When conducting a current dependent resurvey of the GLO survey (usually the section exterior), some general principles are applicable:

- (1) The USIS allotment survey and monumented corners may be the best available evidence of the position of the GLO survey;
- (2) The presumption is that care and good faith were exercised by the USIS surveyor with regard to the evidence of the original survey in existence at the time; the burden of proof to the contrary will be borne by the party claiming differently;
- (3) It may be held generally that the allottee has located his or her lands by the good faith location rule if such care was used in determining his or her boundaries as might be expected by the exercise of ordinary intelligence under existing conditions;
- (4) When an USIS reestablishment of a lost corner or establishment of a minor subdivisional corner has been made by proper methods without gross error, it will ordinarily be acceptable; and
- (5) The USIS allotment survey may be evidence of the intended patent boundary lines and corners.

**10-24.** When conducting a current section subdivision with evidence of a USIS allotment survey, the following applies: If it is determined that the Government’s intent was to patent or convey the land either by aliquot part subdivisions or lots based upon a USIS three-mile or statutory method survey, then the USIS monumented corners (in the interior of the section) are accepted as aliquot part or lot corners as the case may be. The corners are evidence of the lines and corners of the patent and may be the best available evidence of the position of corners or locations of lines of the GLO section exterior survey.

**10-25.** In cases where land descriptions in patents or other documents of conveyance are based upon administrative surveys that are in conflict with official surveys, the land descriptions and the official survey records must be reconciled. In these instances, the Secretary may correct patents or documents of conveyance relating



to Federal interest lands where necessary in order to eliminate errors and/or ambiguities. The surveyor will consult with the appropriate Lands staff when such a situation is identified.

### Subdivision of Section—Others

**10-26.** On occasion, Congress has provided specific direction to heads of agencies other than GLO to conduct surveys, including the United States Geological Survey (USGS) and the Reclamation Service (RS) of USGS, later the Bureau of Reclamation (BOR). Generally these surveys preceded the awarded patents and conformed to the statutory method of subdivision of sections and quarter sections prescribed by 43 U.S.C. 752 and 753. With the filing of these agencies' surveys in the GLO/BLM official survey record, subsequent entries and land actions were based upon these official surveys and monuments.

In some cases, a USGS or other Federal agency survey will be found to have been conducted subsequent to the GLO survey of the township. If the entries are based upon the GLO survey, the USGS or other surveys are akin to an administrative survey by the Federal Government for its own purposes and shall not impair bona fide rights or claims of any claimant, entryman, or owner of lands. In some cases the USGS survey will be found to have provided the basis for entry (the original survey) because it was officially filed and thereby was the "latest official plat" at the time of entry. Today's dependent resurveyor must know which survey record is the "original survey" for each entry. Rarely were lands patented based upon a Federal survey or any other survey not filed in the GLO/BLM official survey records.

**10-27.** When conducting a current dependent resurvey of a township with a GLO survey and a subsequent Federal agency official (re)survey, some general principles are applicable:

- (1) The subsequent Federal agency record and corners may be the best available evidence of the position of the GLO survey;
- (2) The presumption is the agency surveyor exercised care and good faith with regard to the evidence of the original survey in existence at the time of the (re)survey; the burden of proof to the contrary will be borne by the party claiming differently;
- (3) It may be held generally that the claimant, entryman, or owner has located his or her lands

by the good faith location rule if such care was used in determining his or her boundaries as might be expected by the exercise of ordinary intelligence under existing conditions;

(4) If an agency's reestablishment of a lost corner or establishment of a minor subdivisional corner has been made by proper methods without gross error, it is ordinarily acceptable; and

(5) If an entry is based upon the GLO survey and there is conclusive evidence that no attempts were made by the Federal agency surveyor to relate his or her survey in some manner to the original GLO survey, then the Federal agency survey is not evidence of the entry boundary lines and corners.

**10-28.** In some townships Federal agency surveyors did not apply dependent resurvey principles even though bona fide rights as to location had vested under an earlier survey. These surveys were approved, accepted, filed, and used as the basis for patents by the GLO. Gaps and overlaps between patent boundaries, not showing on any official record, may exist. Special instructions or, after a field investigation, supplemental special instructions are used to provide the necessary details for each township.

### Reclamation Project and Farm Unit Section Subdivision Surveys

**10-29.** The Reclamation Act of June 17, 1902 (32 Stat. 388; 43 U.S.C. 372 et seq.), provides for lands feasible of irrigation and reclamation to be utilized by the RS, now the BOR, for the construction and maintenance of irrigation works. The land was to be platted as farm units and receive water for irrigation from such irrigation works.

Section 4 of the Reclamation Act limited the acreage that could be entered. These areas became "farm units." A farm unit is the limit of area representing the acreage that, in the opinion of the Secretary, may be reasonably required for the support of a family. By 1903 the RS engineers were preparing maps, now commonly referred to as farm unit plats. The farm units are announced on the farm unit plats. The plats were transmitted to the GLO land offices to put potential entrymen on notice of the form and limit of area per entry. These farm units were then conveyed from Federal ownership. Land descriptions in the conveyances were based upon the farm unit plats.

Early on, all entries of irrigable lands had to be made according to ordinary legal subdivisions, down to the smallest legal subdivision, 40 acres. By the Reclamation Act, the Secretary had no power to subdivide or change the ordinary subdivisions fixed by law. By the Act of June 27, 1906 (34 Stat. 519; 43 U.S.C. 434) farm units could be fixed at a lesser area than 40 acres. Eventually they could be as small as 5 acres, but as a rule they were fixed by legal subdivisions from 40 to 160 acres each.

The 1906 Act also provided that when it was necessary for the purpose of accurate description or economic irrigation to further subdivide lands to be irrigated or to segregate lands to be reserved or appropriated for reclamation purposes, the Secretary was authorized to cause section subdivision surveys to be made by the officers of the RS. Such subdivision surveys were to be noted upon the GLO, and subsequently, the BLM records. Such subdivisions were to be rectangular in form, except in cases where irregular subdivisions may be necessary in order to provide for practicable and economical irrigation. These farm unit plats, amendment of farm unit plats, orders amending farm unit plats, and all other surveys of the limits of Federal interest in land were to be examined and accepted by the BLM as conformable to the surveying regulations and practice applicable in such cases. No authority was vested in the officers of the RS for the execution of original surveys upon lands embraced with reclamation projects.

After receiving authorization from the Secretary, RS officials in the Washington Headquarters Office, and officials in each project, began to issue survey instructions for these section subdivision surveys. The surveyors were instructed to make surveys in accordance with the GLO *Manual of Surveying Instructions*, and Circular on *Restoration of Lost or Obliterated Corners and Subdivision of Sections*. Soon, differences in field and platting procedures between the RS/BOR and the GLO began to appear.

**10-30.** It is the dependent resurveyor's task to determine whether bona fide rights as to location would be impaired if a careful and faithful retracement and dependent resurvey of the farm unit survey is not conducted. During a dependent resurvey involving reclamation farm units or irregular areas, a study of nationwide and project specific RS/BOR memorandums and instructions for the date and location must be made to assure proper resurvey techniques were applied. The field notes and plat and related records of the reclamation survey must be studied.

While a copy of the field notes and plat were to be filed in the Surveyors General or Cadastral Survey offices, some are missing from the official records. A search of the BOR and the State Irrigation District records for the originals or copies will be conducted. By RS/BOR instructions, some field notes of restoration of lost or obliterated corners were not forwarded to the Washington Offices of the RS/BOR or GLO.

Rights-of-way have been reserved for highways and access roads to farm units along section lines and other lines shown on the farm unit plats. Other rights-of-way may have been reserved by or issued by the Government over and across the farm units and irregular areas. Many resurveys and section subdivision surveys were made during the construction of reservoirs, irrigation works, and the areas bordering thereon, where an irregular boundary passes through several sections and closes on section or subdivision-of-section lines. Some rights to use land or an estate in land administered by the BOR have been granted by the BOR Regional Directors.

Patents or other administrative actions, based upon RS/BOR minor subdivision surveys, were and are to be described with reference to the plat thereof as approved by the GLO/BLM. In sections where no such minor subdivision has been made, the patent or other administrative action shall bear the description of the legal subdivision of the current official plat. The officially filed farm unit plat supersedes the original survey plat and the farm unit becomes the smallest legal subdivision subject to disposition. Until the description can be identified upon an official plat, the expanse of land is officially unsurveyed and is not subject to patent or administrative action.

**10-31.** By law, delegation of authority, and departmental policy, all actions taken that serve to change the official public land survey system (PLSS) records are to be conducted under BLM instructions and approval. The proper and timely identification of the boundaries of reclamation lands is paramount to instituting good land management practices. The BLM is responsible for the timely administration, coordination, and execution of the PLSS, including development and maintenance of a system for the assimilation, storage, and dissemination of survey data for use by reclamation interests.

### **Nonrectangular and Other Metes-and-Bounds Surveys**

**10-32.** Situations requiring deviation from the general rules for rectangular surveys are limited in nature and

generally authorized and governed by a specific congressional act. In addition, public land laws authorize the Secretary of the Interior to conduct a program for the marking and describing of land at his or her discretion and under such rules as he or she may prescribe. In circumstances when departure from the regular rectangular survey is necessary for coordination with other programs related to disposition, acquisition, and management of land within the Federal land tenure program, a special and detailed survey may be required. After the affected land is identified, special steps must be taken to maintain records that relate the nonconforming unit of land to the regular rectangular survey of lands under which the ownership, use, or restrictions of other lands is identified.

Notwithstanding the careful maintenance of special records, the different systems of land identification appreciably increase the likelihood of boundary disputes and conflicting claims under Federal programs. These burdens appear to amply justify the general rule of Federal boundary survey authority lying with the GLO/BLM.

**10-33.** Nonrectangular surveys, sometimes referred to as metes-and-bounds surveys, are required to define the boundaries of irregular areas of land that are not conformable to legal subdivisions. This type of survey may involve lode mineral claims, early placer claims and millsites, small-holding claims, donation land claims, private-land grants, townsites, forest-homestead entry claims, reclamation farm units, congressionally or administratively designated areas such as national parks and monuments, Indian reservations, tracts, lighthouse reservations, exchanged or acquired lands, U.S. Surveys in Alaska, or the like.

Congress has enacted numerous laws pertaining to the disposal, management, and acquisition of the Federal lands that sometimes require nonrectangular surveys. Many of these acts have been repealed. However, special legislation and Executive orders enacted in recent times have set aside certain Federal lands as special areas for specific uses or with use restrictions, such as Wilderness Areas, Wild and Scenic River corridors, Natural Areas, and Conservation easements. Though survey of these boundaries may not affect land title, the surveyor will exercise due diligence to ensure that they are properly located on the ground. Be aware that the limit of the public's rights to the use and enjoyment of the land is determined by the boundary location, and the determination of that location may become a matter of future litigation.

**10-34.** The specific requirements prescribed elsewhere in the Manual also govern nonrectangular surveys. These include such subjects as:

- (1) limits of closure;
- (2) ties to preliminary location or listing surveys;
- (3) location based upon official maps and documents;
- (4) marking corners and corner accessories;
- (5) meandering streams and other bodies of water;
- (6) connecting a corner of a tract if located upon unsurveyed land to the rectangular system of surveys;
- (7) determining geographic coordinates of monuments;
- (8) locating improvements and noting important topographic items;
- (9) determining the direction of each line with reference to the true meridian; and
- (10) closing against withdrawn areas.

**10-35.** Generally, no special surveying problems are presented in nonrectangular surveys. However, in cases of specific legislation, the Congressional intent of the boundary location is derived from an official map or other document of public record. Often these documents were prepared by persons with little or no experience with land descriptions or land surveying. Regardless of this fact, the document of record shall govern the location of the boundary to be established, unless a clerical or typographical error can be proven. In addition, the local official responsible to manage these special areas can be of great assistance in interpreting intent as it relates to natural features.

**10-36.** The survey procedure is similar for each type of claim, grant, exchange, acquisition, easement, area, or reservation having irregular boundaries. A monument is required at each angle point of the boundary. The angle points are given serial numbers beginning with No. 1 at the initial point. For special areas that require extensive numbers of angle points, it may be

advantageous to limit the sequential serialization to the individual section where the points fall (e.g. AP No. 1, No. 2, No. 3, section 13, Eagle Creek Wilderness; AP No. 1, No. 2, No. 3, section 14, Eagle Creek Wilderness; etc.). This scheme should provide additional locative information for each monument, and avoid numeric duplication or omission. Monuments on the boundary should not be more than 45 chains apart, or at lesser intervals providing practical location notice for the land management agency and the public. To this end, witness points are established on the tops of ridges, at streams, trails, roads, or other accessible and prominent places. In the survey of boundaries of large grants, areas, or reservations, mile corners are established in addition to the angle points and witness points. If practical, the numbering of the angle points will begin with No. 1 at the northeast corner and proceed around the area, running westerly from the initial corner. The plan of monumentation should be designated in the special instructions for the survey.

**10-37.** Nonrectangular surveys located upon surveyed land are connected to at least one regular corner of the subdivisional survey. If the location is within an unsurveyed township, the special instructions should call for the running of a connecting line to an established corner if within 6 miles. The geographic position of the established corner or initial point, will be determined and within a positional tolerance defined in the special instructions.

**10-38.** In cases where Federal interest lands are to be segregated and defined by an irregular boundary, and the area to be surveyed lies entirely within a surveyed section, it should be designated as a lot of that section and be numbered accordingly. Areas within a township that encompass land in multiple sections can be lotted within each involved section, such that a land description can be assembled with lot designations, by section, to embrace the entirety of the subject land. Abutting irregular non-Federal lands that require a special designation for identification should be designated as a parcel of that section and be lettered accordingly (sections 10-2 through 10-4).

**10-39.** Nonriparian boundaries of irregular areas are sometimes partly or entirely located along a natural boundary such as a watershed, offset from a road centerline, or along an elevation contour. Boundaries of this sort are normally winding, and it should be understood that they may be technically defined by the location of the natural feature and not by the straight lines between angle points. In other cases, the boundary is

defined by the monumentation at every angle point and by the straight (mean bearing) line between angle points. The legal location of the boundary is derived from the authorizing documents and subsequent technical adjustments.

### Townsite Surveys

**10-40.** Numerous general and special acts make provision for the executive withdrawal of public lands for townsite purposes. A townsite survey, in public-land surveying practice, is a survey made within one or more regular units of the township subdivision by which the land is divided into blocks, lots, streets, alleys, rights-of-way, and reservations as a basis for the disposal of title in village or town lots.

Ordinarily special instructions are prepared for a preliminary reconnaissance of the townsite and for the dependent resurvey and subdivision of sections that may be necessary. The field examination should ascertain the layout, give proper regard for existing locations where rights have already been acquired, and provide for rights-of-way, public grounds, and other important conditions that should receive consideration. These are followed by supplemental special instructions based on the findings of the examination and providing for the townsite survey proper.

### Planning the Survey

**10-41.** The Federal lands have been laid off into town blocks, lots, streets, alleys, rights-of-way, and reservations since early in the 19<sup>th</sup> century. Federal townsites have been authorized under a large umbrella of legislation, including acts specific to a single townsite, public domain townsites, townsites on shores of harbors or prospective centers of population, Alaska trustee townsites, mineral lands townsites, Indian townsites, reclamation townsites, Alaska Railroad townsites, Alaska Native trustee townsites, and National Forest townsites. In 1971, authorization to survey previously conveyed lands within Alaska native villages in the form of townsite surveys was established by the Alaska Native Claims Settlement Act (ANCSA) and are referred to as “14(c) surveys” (sections 10-55 through 10-57).

The statutes, regulations, circulars, instructions, and case files governing each townsite must be reviewed prior to survey. In addition, the special instructions, field notes and plats of the original townsite survey and any subsequent resurveys must be studied prior to dependent resurvey. Some townsites were originally surveyed



under statutory authority by authorized officials other than the GLO or BLM, with the plat being submitted to the latter for review and approval. In these cases, careful research into local records and conditions may be required.

Dependent resurveys of federally authorized townsites are akin to dependent resurveys of privately created lot and block surveys and descriptions. They both involve questions and issues of (1) simultaneously or sequentially created titles, (2) simultaneous or sequential surveys, (3) land status, (4) interior or exterior boundary line of the townsite, (5) dedications, (6) vacations, (7) court of competent jurisdiction, (8) chain of title, (9) chain of surveys, and (10) best available evidence, for example.

It follows that Federal townsite statutory and regulatory regimes, with few exceptions, have adopted common dependent resurvey principles applicable to private lot and block surveying. The exceptions are specifically addressed in the statute authorizing the townsite, or in Departmental circulars, regulations, or instructions issued to implement the authorizing statute.

Townsite resurveys vary little from the rules governing dependent resurveys of the rectangular surveys. The standards for corner identification and evaluation of evidence are the same, as are the rules for treatment of blunders, excess or deficiency, and proration, unless the contrary is clearly apparent. For simultaneous subdivisions, interior monuments that represent the actual lines run by the original surveyor are presumed to control, irrespective of whether the courses, distances, and street improvements agree with the plat. In the absence of evidence of a corner or line location, distances and angles on the plat are presumed to govern location. Streets and other rights-of-way represent more than individuals rights and the former create blocks. Generally any excess or deficiency is contained within the block. A possible exception is when a street or right-of-way location is lost and a uniform measurement index can be established.

Local markers and monuments that can be proved to be neither correct nor incorrect, but are locally accepted as being correct and have the reputation of being good faith perpetuations of the intended corner positions may be accepted per the doctrine of repose. A local marker or monument that can positively be proved as an incorrect perpetuation of the original position, although accepted by many, cannot be accepted as the original corner position.

**10-42.** Townsite surveys fall into two general classes, those with few or no prior improvements and those where villages or towns already exist at the time of survey. A townsite may be planned in connection with some Federal project or in support of a reconveyance system where the survey must fit special requirements already set up, or to identify existing improvements and occupation. Whatever class the townsite falls in, a study of approved townsite plats with similar elements is helpful in planning. A visit to some of these developed areas may be worthwhile to gain understanding of proper survey planning. For occupied towns and villages, preliminary planning requires collaboration with community officials.

**10-43.** Consideration of every facet of townsite planning is beyond the scope of this Manual. There may be need for consultation with specialists in architectural and industrial planning, landscaping, and various branches of city engineering such as water supply, sewerage, street, highway, railroad, and airport locations. Provision is needed for public school grounds, other public buildings, and park areas. For native villages in Alaska there may be need for consultation with specialists in ANCSA and reconveyance issues. All these things are interdependent, and, wherever possible, local planning bodies should be asked to present plans that meet with zoning requirements. The planner should also refer to some of the many books on the subject of town and village planning.

### *Surveying the Townsite*

**10-44.** The rules that follow set out the minimum specifications for the survey procedure, the monumentation, and the elements of plat construction by which the blocks, lottings, and rights-of-way may be identified. The detail of the plan should be set out in the special instructions.

The character of the area, including the topography, its location, and whether it is a new townsite or an addition to an old one, to a large extent determines the detail of the street, block, and utility right-of-way system. A topographic survey is of value in ascertaining the layout best suited; the special instructions should call for the appropriate contour interval. Wherever practicable, especially where there are existing improvements, photogrammetry, and remote sensing should be employed in the preliminary examination with paneled boundary monuments incorporated in the aerial control.

**10-45.** In the typical townsite the block dimensions are usually between 300 and 400 feet. The principal streets



are usually made 80 feet in width, though frequently as much as 100 feet where greater width is called for. The less important intersecting streets, though narrower, are seldom given a width of less than 60 feet.

The normal frontage of the lots is 50 feet. Unless conditions require a special plan, the whole system is laid out on cardinal. The blocks are given serial numbers, usually beginning with the northeast block and proceeding with the numbers alternately to the west and to the east. The lots are given serial numbers within the block.

**10-46.** The foot unit is employed in townsite surveys, and lengths of lines are reduced to the horizontal. The field traverse of the townsites will ordinarily be made to close within an error not to exceed 1/5000, and never to exceed 1/2000. The determined lengths of lines and their bearings are balanced to secure a perfect closure (subject to the apparent misclosure described in sections 2-21 and 2-22) for the data that are to be carried to the plat. These data should leave no discrepancy whatever in any calculated position, whether working from one monument to another, or between any two points.

**10-47.** If the proposed townsite is in an area already surveyed, great care must be exercised to identify the original section lines and to subdivide the section or sections in the proper legal manner to ascertain the assigned townsite boundaries. Permanent monuments are placed at each angle of the townsite boundary. These may be the regulation post or a magnetically detectable tablet seated in a concrete post, 3 feet long and at least 8 inches square in cross section. Markings consist of the usual subdivisional identification marks, the capital-letter initials of the townsite name, and the letters "TS" in the appropriate quadrant.

**10-48.** The boundary streets are laid out first, then the other streets, blocks, lots, rights-of-way, and reservations. Permanent control monuments are established and connecting line measurements made as necessary to afford a precise relocation of any point. All data, including true bearings, connecting lines, and dimensions of streets, blocks, lots, rights-of-way, and reservations are carried to the townsite plat. Their sufficiency may be tested by the ease with which the position of any given point can be ascertained and the area of any lot can be calculated. If there are curved lines, the curve elements are shown on the plat. A minimum of three items of curve data is required: radius, arc distance, and long chord bearing and distance. The central angle may also be included.

**10-49.** Where permanent monuments are placed at the intersections of the street center lines, connections are made to the block corners to assure a ready restoration of any block corner that might be obliterated. The regulation post or a magnetically detectable tablet seated in a concrete post, 24 inches long and at least 6 inches square in cross section, may be used. These should be magnetic subsurface monuments, placed as much as a foot below the probable grade line of the street and marked only for the point of intersection. A marker is placed at each intersection.

**10-50.** Where the street or right-of-way center-line intersection is not marked, the adjacent block or lot corners are monumented. Durable markers such as regulation posts are set at the block corners and the front corners of the lots. These points are always monumented. The lot corners are set only on the block lines. The monuments at block corners are marked with the appropriate numbering. A permanent monument is placed at each angle point within the block boundary, when irregular, and at each point of curvature and point of tangency if the line of the block has been placed on a curve.

**10-51.** Lengths of lines and all angles or bearings are determined in the field for all irregular blocks and lots. In such cases both the side lines and back lines are always measured in the field. The dimensions are carried to the plat wherever needed, as when the lines cannot be readily located by the method of intersections. The geographic position of at least one monumented corner of a townsite will be determined.

### *Use of Photogrammetry*

**10-52.** Photogrammetry is especially useful in showing the irregular layout of an existing town or village. With the extent of the improvements known, the streets, blocks, lots, rights-of-way, and reservations can be laid out on a trial basis on the photographs in order to determine the best plan. If the coordinates of lot corners, street and right-of-way center lines, monuments, and other points of significance are to be determined photogrammetrically, the work should be done with a first order plotting instrument, by analytical methods or equivalent. A sufficient number of positions are marked in advance of photography to reduce the field measurement work to a minimum.

### *Field Notes and Plats*

**10-53.** The field notes of the townsite survey describe the dependent resurvey of the old section lines, the

restoration of any needed corners, the subdivision of sections, and the controlling monuments. All important connecting lines and measurements between the boundary monuments and the corners of the block lines, or to the permanent monuments marking the street and other right-of-way lines adjacent to the boundaries, are included. The plan followed in the townsite survey is explained and a general statement made as to the monumentation. Beyond this, the further detail of all directions and lengths of lines is carried to the plat but omitted in the field note record. If any improvements are unavoidably left in conflict with the townsite layout, the information is brought out in the field notes but can be omitted from the plat. The survey record may be a plat only, with the field notes written on the plat.

**10-54.** Townsite plats are usually published at a scale of 200 feet to an inch, but they are frequently drawn at a somewhat larger scale, subject to reduction when published. A marginal diagram is usually supplied in order to show the relation of the townsite boundaries to the section lines, with lengths of lines here given in the chain unit. Tenths and hundredths of links are used where appropriate for making reduction to the lengths of lines shown on the main drawing.

On the main drawings, all lengths of lines are shown in the foot unit, with tenths where needed. All directions and lengths of lines, and connecting lines to monuments are given on the plat with a view to the location of any point by calculation from the points of permanent control. This facilitates ready calculation from the plat of the area of any individual lot or expanse of land.

The main drawing shows the block and lot numbers, areas of lots and other expanses of land to the nearest square foot, and the designation of streets and other rights-of-way by letters, numbers, or names. In drafting the data for the regular blocks, some of the figures that would be applied in each lot of the block may be omitted if it is left clear within the block that the lottings are regular for dimension and area.

All permanent monuments and positional relationships are shown on the main drawing. The widths of the streets and other rights-of-way should be plainly shown but not repeated needlessly. Where all of the lots in a block are of the same dimensions, it is sufficient to show the measurements only along the block lines. A memorandum is supplied to note the general plan of monumentation, with an outline description of the monuments.

If there are reservations for public-school grounds, or of grounds for other public buildings or parks, the provision should be stated in the special instructions. The designated blocks are shown upon the plat, numbered regularly and titled, but not subdivided.

Reference should be made to chapter IX for the usual requirements regarding the title and the certificates that are to appear on the townsite plat.

### **Alaska Native Village Corporation Conveyance of Lands Surveys**

**10-55.** Surveys authorized by 43 U.S.C. 1613(c), often called ANCSA 14(c) surveys, occur when the Secretary finds the selection by a Village Corporation for a Native village qualified, and the Secretary issues to the Village Corporation title to the surface estate. The Village Corporation, in turn, conveys parcels to qualified claimants. When all the claims are identified by the Village Corporation, they are posted on the ground and shown on a map. This map constitutes the origin of a plan of survey. The BLM then surveys, monuments, and plats the selected lands and the village conveyed lands for legal description purposes. The intent of the survey is to have the selected lands and village conveyed parcels surveyed in the same configuration, relative position, and size as shown on the map submitted by the Village Corporation, as conditions allow.

The technical survey process has much in common with the general class of townsite surveys where the town or village is occupied. A study of the authorizing statutes and regulations governing townsites highlights similarities and specific differences in administration and survey requirements from ANCSA 14(c) surveys.

The special instructions will state whether the posting on the ground, often called staking, the title descriptions, or acreage goals will control the corner positions of the survey. The special instructions will identify which lines are adjustment lines to meet the intent of the plan of survey.

**10-56.** A major conflict that is found at any phase of the plan of survey development or during the field survey is due cause to return to the Village Corporation with a request for additional clarification. The conflict is identified in a written statement, which, if appropriate, will recommend a way(s) to resolve the conflict. The assigned surveyor may be given the authority to make minor adjustments to the posting on the ground during

the course of the field work to accommodate one or more of the following situations:

- (1) to fit the designated width and produce uniform parallel sided rights-of-way;
- (2) to ensure that the boundaries do not trespass on claims or improvements originally intended for another claimant;
- (3) to ensure there are no conflicts with official surveys, or any local surveys marking bona fide rights as to location;
- (4) to avoid creating unmanageable gaps or strips of land;
- (5) to maintain the original intent of the village conveyance agreements;
- (6) to adjust for designated area; or
- (7) to ensure that the 43 U.S.C. 1613(c) claim(s) remain on lands conveyed to the Village Corporation.

The surveyor must document and submit changes made during the course of the field survey to the supervising official. Any major change requires review and approval by the Village Corporation.

**10-57.** All parcels will be tied to each other and at least one monumented corner of the village will be tied to the nearest monumented interior or exterior corner of the township that the village is in. The geographic position of at least one monumented corner of the village will be determined. The Secretary's copy of the plat, and field notes, if any, will be submitted to the BLM Washington Office for filing.

## Surveys and National Forest System Lands

### *National Forest Homestead Entry and Allotment Surveys*

**10-58.** National Forest Homestead Entry Surveys, under the Act of June 11, 1906, as amended (34 Stat. 233), and National Forest Indian Allotment Surveys, under the Act of June 25, 1910 (36 Stat. 855, 863; 25 U.S.C. 337), are examples of Congress devising legislation to meet a perceived immediate need. In this case large bodies of surveyed and unsurveyed Federal interest lands, better suited for grazing or agricultural uses than for forest uses, were being included within the National

Forest System. To obviate this defect, Congress supplied a new legal mechanism whereby the lands suitable for grazing or agricultural entry be definitely segregated from all lands that are properly required for forest uses.

In unsurveyed areas, these segregation surveys were generally nonrectangular, without regard to the lines of the public surveys, usually made by employees of the Forest Service under special instructions issued by the GLO. The surveys were often many-sided figures with the intent to encompass the grazing and/or agricultural land. Sometimes the homestead entry or allotment claim were surveyed into more than one tract, with one tract reserved in fee by the United States for road purposes.

There were often preliminary or listing surveys prior to the final or patent survey. The survey field notes and plat were examined by the GLO. The field notes and plats were approved and filed by the GLO prior to the issuance of patent by the land office. The National Forest Homestead Entry Survey Act was repealed on October 23, 1962 (76 Stat. 1157).

These departures from the rectangular system are historical examples within the PLSS that necessitated cooperative development and administration between, in this case, the Interior and Agricultural Departments. Separate and joint circulars, use books, instructions, administrative manuals, and regulations were issued. It is incumbent upon the surveyors who are to dependently resurvey these types of surveys to acquaint themselves with these general instructions as well as with the special instructions, field notes, and plats for the specific survey being retraced.

### *General Forest Exchange Surveys*

**10-59.** Exchange surveys, under the Act of March 20, 1922 (42 Stat. 465; 16 U.S.C. 485) as amended, are conducted under the Federal survey authority or by an administrative survey conducted under State authority. These surveys are in support of National Forest System landownership adjustments. Certain requirements authorized by the Act, together with the consideration of special conditions not fully covered by this Manual, are outlined in the cooperative procedures between the Forest Service and the BLM. Special consideration should be given to maintaining the integrity of the Federal land tenure records system for the orderly administration of Federal lands generally.

**10-60.** The procedure outlined in this Manual for the preparation of field notes and plats for fragmentary and nonrectangular surveys will be followed, including the

regular certificates of approval, acceptance, and filing. The purpose of an exchange survey is to mark the boundaries of a particular area on the ground and to furnish a plat and a set of field notes representing the survey as the basis for conveyance, acquisition, or other administrative action.

Under the provisions of the law, the BLM is responsible for the correctness of exchange surveys and the field surveying may be executed by employees of the Forest Service or by local surveyors under the BLM or Forest Service direction and control. All lands subject to an exchange will be properly described on the basis of either a survey executed in accordance with the PLSS laws and standards of the United States or, if those laws and standards cannot be applied, the lands must be properly described and clearly locatable by other means as may be prescribed or allowed by law.

Before title can pass land shall be identified by survey. Because the land surrendered or selected may be (1) less than a legal subdivision, (2) the applicant or the Government does not own the entire legal subdivision, (3) a portion of a legal subdivision offered the Government is not valuable for National Forest purposes, or (4) the United States desires to retain ownership of a portion or portions of a legal subdivision selected by the applicant because that lot or lots are chiefly valuable for National Forest purposes, the special instructions for such surveys issued must be complete and refer to the particular sections in the Manual pertaining to technical standards and the details involved with nonrectangular surveys (sections 10-32 through 10-39). The regular technical procedure prescribed for executing such surveys should be followed. The lands offered for exchange and not covered by public land surveys will be identified by nonrectangular surveys. Such surveys and the plats and field notes, upon request by the National Forest System Authorized Officer, are reviewed and, if found in accordance with the PLSS laws, conformal to this Manual and the standards of the United States, the surveys are approved by the BLM.

In connection with the acceptance of title to the offered land, the necessity for the execution of an exchange survey to identify on-the-ground by official survey the location of excepted strips of land is not required, unless requested by the Authorized Officer.

### *National Forest System Lands Small Tract Surveys*

**10-61.** National Forest System Lands small tract surveys authorized by the Act of January 12, 1983 (96

Stat. 2535; 16 U.S.C. 521c-521i), is another example of Congress devising legislation to meet a perceived immediate need. In this case, plots of land within the National Forest System were identified with ownership disputes associated with mineral survey fractions, encroachment problems, or management problems associated with unused road rights-of-way. To resolve these encroachment and management problems, Congress supplied a new legal mechanism whereby these plots are definitely segregated and Federal interest land is sold, exchanged, or interchanged.

**10-62.** The National Forest System Lands affected are as follows:

- (1) Plots of 40 acres or less interspersed with or adjacent to lands that have been transferred out of Federal ownership under the mining laws and that are determined, because of location or size, not to be subject to efficient administration are referred to by regulation as “mineral survey fractions”;
- (2) Plots of 10 acres or less encroached upon by improvements occupied or used under claim or color of title by persons to whom (a) no advance notice was given that the improvement encroached or would encroach upon such plots and (b) in good faith relied upon an erroneous survey, title search, or other land description indicating that there was not such encroachment; or
- (3) Road rights-of-way, reserved or acquired, substantially surrounded by lands that are not owned by the United States and that are no longer needed by the United States.

**10-63.** Many of the affected plots are fractional parts of legal subdivisions or narrow strips of land. All Federal and non-Federal interest lands subject to this authority to adjust land ownership will be properly described on the basis of either a survey executed in accordance with the PLSS laws and standards of the United States or, if those laws and standards cannot be applied, the lands must be properly described and clearly locatable by other means as may be expressly prescribed or allowed by law.

When a survey is necessary, these segregation surveys are conducted under the Federal survey authority or by an administrative survey conducted under State authority. For the administrative surveys, when transmitted by



the National Forest System Authorized Officer to the BLM for their records, the State Office Chief Cadastral Surveyor will examine them and, when found to conform to the system of surveys adopted by the United States, will construct, approve, accept, and officially file a plat of survey. When such an administrative survey is found not to be in accordance with the system of United States surveys, the Cadastral Chief returns the survey, with an explanation of changes necessary to bring it into conformity, or upon request, executes the segregation survey.

The special instructions will show the areas of land to be segregated, or acquired, if applicable. This, by regulation, is the minimum necessary to resolve the encroachment or land management problem(s). The Authorized Officer is expected to provide the extent of the segregation. It may often be the case that relotting the remaining Federal interest lands and lotting the newly acquired Federal interest lands is necessary.

**10-64.** This system is another recent example within the PLSS that necessitates cooperative development and administration between two Departments. Separate and joint memorandums of agreement, administrative manuals and handbooks, instructions, and regulations are issued. It is incumbent upon the surveyors who are to perform these types of surveys or resurveys to acquaint themselves with these general instructions as well as with the management objectives, case file, special instructions, field notes, and plats for the specific survey project.

### *National Forest Townsite Surveys and Education Land Grant Surveys*

**10-65.** By the National Forest Townsite Act of July 31, 1958 (72 Stat. 438; 7 U.S.C. 1012a; 16 U.S.C. 478a; amended by sec. 213 of the Act of October 21, 1976; 90 Stat. 2760) and the Education Land Grant Act of December 28, 2000 (114 Stat. 3070; 16 U.S.C. 479a) when a survey is necessary, these segregation surveys are conducted under the Federal survey authority or by an administrative survey conducted under State authority. For administrative surveys, when transmitted by the appropriate Authorized Officer to the BLM for their records, the State Office Chief Cadastral Surveyor will examine them and when found to conform to the system of surveys adopted by the United States will construct, approve, accept and officially file a plat of survey. In case such administrative survey is found not to be in accordance with the system of United States surveys, the Cadastral Chief returns the survey, with an explanation

of changes necessary to bring it into conformity, or upon application, executes the segregation survey.

### **Public Lands Small Tract Surveys**

**10-66.** The Act of June 1, 1938, (52 Stat. 609), as amended by the Acts of July 14, 1945 (59 Stat. 467) and June 8, 1954 (68 Stat. 239; 43 U.S.C. 682a-e), was repealed by the Act of October 21, 1976 (90 Stat. 2743, 2789). As amended, the Act provided for the sale or lease of small tracts not exceeding 5 acres of land that, upon a land classification field examination, were identified in a classification order as not suitable for agricultural use or for grazing, but suitable for a home, cabin, camp, health, convalescent, recreational, business, or community site, subject to terms.

The survey made to delineate the small tracts differed from townsite surveys in that the small tract survey normally followed a pattern of progressional subdivision down to the desired lot sizes without block designations or the segregation of streets and alleys. The small tracts were typically described by the rectangular system, being aliquot parts of a section, while many others were nonrectangular by description and described as lots. They were created in contiguous groups and by isolated tracts, with some contiguous tracts being simultaneous conveyances and some sequential conveyances, the sequential conveyances with potential junior-senior issues. Regulations provide for reserving rights-of-way for street and road purposes and for public utilities in the patents or leases.

Conducting a proper dependent resurvey of a small tract survey requires a basic understanding of how they were surveyed originally. The special instructions and the assigned surveyor should make reference to and study the small tract regulations, agency studies, and field examination prior to classification, the classification order, and the serial case file affecting each small tract. Following is a summary of general instructions for conducting small tract surveys and dependent resurveys.

### *Rectangular Small Tracts*

**10-67.** By regulation, small tracts are in compact form, in units of 5 acres or aliquot parts thereof. The official township plat provides the basis for the description of small tracts and no further surveys are necessary. However, as an aid in identifying small tracts on the ground, the areas classified for administration as small tracts should be subdivided by survey in order that at least one corner of each such small tract is marked on



the ground. The condition of the original survey and the ease of identifying the individual small tracts on the ground are governing factors in deciding whether additional survey work is required.

### *Supplemental Plats*

**10-68.** To obtain land descriptions in cases where a field survey is not required, the rectangular small tracts should be identified by lot numbers. An official supplemental plat must be prepared for that purpose by protraction from existing records. Such identification is effective as of the date of official filing of the plat in the land office. Where a small tract is situated in a previously designated lot, a supplemental plat is required to afford a suitable description. If the subdivision of the lot results in narrow strips or other areas containing less than 2½ acres not suitable for sale or lease as separate units, such excess areas may be included in the adjoining 5 acre small tracts.

### *Irregular Small Tracts*

**10-69.** When the rectangular form is not the most desirable plan for development of an area, small tracts irregular in form, not in excess of 5 acres each, may be leased or sold. An official survey is required of an irregular small tract for purpose of identification and description in the lease or patent. If the action is initiated upon an offer to lease or purchase, the applicant is required to make an advance payment, equal to the estimated cost of executing the survey, before the work begins. Any excess payments are credited prior to the issuance of the lease or patent.

Where surveys of irregular small tracts are planned for administrative purposes, the cost of the survey is considered as an expense under normal appropriations and, if the small tracts are sold, the selling price shall not be less than the cost of survey of the particular small tract. Where a group of contiguous or closely associated small tracts are surveyed at one time, the cost of survey is prorated among the several small tracts on an acreage basis. Each irregular small tract is designated as a lot on the official plat.

### *Small Tracts on Unsurveyed Land*

**10-70.** Unsurveyed Federal lands are not subject to lease or sale under the small tract acts. However, the applicant may file a request for the survey of the lands. The description on the application must be sufficiently complete to identify the location, boundary, and area of

the land. Upon completion of the survey and after the plat is officially filed, the surveyed area is subject to the provisions of the act and an offer to lease or purchase may be filed.

### *Field Survey*

**10-71.** The first requirement of the survey is the establishment or reestablishment of the section boundaries. The ensuing subdivision into small tracts should not be made without a study of the terrain. Under favorable circumstances the section may be subdivided into legal subdivisions and thereafter into lesser aliquot parts. However, it is sometimes necessary to depart from normal subdivision lines in order to make the tract layout compatible with drainage features, existent roads, and improvements on adjoining lands.

**10-72.** Aerial photographs and topographic maps are helpful in devising a suitable plan of subdivision. A preliminary survey and development of a topographic map may be necessary. The small tracts might then take an irregular form so as to fit the topography. While the individual plots are called “small tracts,” they are designated on the official plat as lots when not describable as aliquot parts of the section. If the survey is in the vicinity of urban or suburban development, the plan should be discussed with local officials as to suitability.

**10-73.** Small-tract surveys should always be executed within a closure limit of 1:2560 in either latitude or departure. If stricter limits are desirable in an urban or suburban area, provision will be made in the special instructions.

**10-74.** All corners of each lot should be monumented. Regulation monuments are used on section boundaries and on subdivisional lines down to 1/64 section lines. Further monumentation may be with approved materials called for in the special instructions. On an irregular lotting scheme regulation monuments should be used at approximate intervals of 10 chains, preferably at inter-visible points. Where all corners of an individual lot can be established on the lines of larger subdivisions, the minor subdivisional lines need not be surveyed. All monuments set will be uniquely marked to represent the corner position.

**10-75.** The final field notes contain the regular record of the survey or resurvey of the section lines and subdivisional lines to the extent of all actual field surveys. The plat shows all data relating to established lines and measurements. Lot lines and measurements developed

by protraction should be appropriately dashed and shown parenthetically. Bearings should be shown to 15" of angular value and distances to tenths of links. Each "small tract" is assigned an appropriate lot number, and the area is shown to hundredths of an acre.

**10-76.** Topographic detail on the plat should be kept to a necessary minimum and subordinated to the base data. Anticipated new rights-of-way for road and public utility purposes, to be reserved in the lease or conveyance of the lots, need not be shown. It may be desirable to show the scheme of corner monumentation on the plat by appropriate symbols.

## Mineral Leasing Act Surveys

### *Not a Mineral Survey*

**10-77.** The survey of land described by a Federal lease authorized by the Mineral Leasing Act of 1920 (30 U.S.C. 181 et seq.) or other statutes authorizing mineral leasing, is not a mineral survey. The surveyor needs to recognize that these lease boundaries are Federal interest boundaries and, when adjoining lands beneath navigable waters or lands beneath meandered nonnavigable waters, may have riparian characteristics different from those encountered under Federal law for fee ownership boundaries.

### *No Riparian Rights*

**10-78.** From the general tenor of the Mineral Leasing Act, it is evident that Congress intended that all operations under prospecting permits or leases should be conducted upon a per-acre basis. It is evident that it was not within the intention of Congress that any person whose application called for a specific tract of land, including a certain number of acres, should receive rights on any larger tract containing a greater number of acres. Congress has, in effect, established a procedure for the exploration and/or development of Federal lands containing leasable minerals, which, of necessity, excludes the applicability of the common law concept granting to riparian owners rights to the waterline or, in a stream bed, to the center thereof, unless the lease or permit expressly includes such lands (*P&M Petroleum Mgmt.*, 140 IBLA 228 (1997); *David A. Provinse*, 35 IBLA 221 (1978); *Sam K. Viersen, Jr.*, A-30063, 72 Interior Dec. 251 (1965)).

For Mineral Leasing Act purposes, whether the lease description of lands landward of lands beneath

navigable waters or lands beneath meandered non-navigable waters will include the upland between the meander line and the water line, or the accretions, or the submerged lands, must be decided in each case. Lease descriptions must make it abundantly clear that the description intends to cover all of the land within a metes-and-bounds description with fixed and limiting boundaries, and not limited by the legal subdivisions with ambulatory boundaries.

### *Meander Lines are Boundary Lines*

**10-79.** The general rule that meander lines are not boundary lines may not be applicable to lease boundaries authorized by the Mineral Leasing Act. As a general rule, a lease authorized by the Mineral Leasing Act, described by legal subdivisions of lands shown on the official plat as riparian, extends to the meander line and not to the waterline. The Federal common law rules of accretion, erosion, reliction, and submergence may not apply to lease boundaries bordering lands beneath navigable waters and lands beneath meandered nonnavigable waters. The riparian Federal common law rules are pertinent only when they affect a boundary between areas owned by the United States and third parties. When a surveyed lot of riparian public land is leased under the Mineral Leasing Act according to the plat of survey, the area covered by the original lot remains in the lease, even though part of the lot is thereafter covered by water, so long as the United States retains title to the river bed (*James L. Harden*, 15 IBLA 187 (1974)).

The boundary of a Federal mineral lease authorized by the Mineral Leasing Act landward of lands beneath navigable waters may be the meander line indicated on the official plat of survey, and not the waterline (*David A. Provinse*, 35 IBLA 221 (1978)). This same exception to the general rule is applicable for a Federal lease under the Mineral Leasing Act for lands adjoining lands beneath meandered non-navigable waters. In construing the extent of the area conveyed by a lease issued under the Mineral Leasing Act, principles of Federal law shall be applied (*Sam K. Viersen*, A-30063, 72 Interior Dec. 251 (1965)).

For Mineral Leasing Act purposes, and in the context of a lease landward of lands beneath meandered nonnavigable waters, the meander line is simply a line between two tracts of land owned by the United States, and it has been held that no lands beyond it pass with a lease of the tract it borders (*Sam K. Viersen, Jr.*, A-30063, 72 Interior Dec. 251 (1965)).

### *Unsurveyed Lands*

**10-80.** When the area to be selected for a lease is unsurveyed lands, the lease shall be surveyed under the direction and control of the BLM, in conformity with the law and regulations governing surveys of the public lands and at the expense of the applicant for the lease (25 U.S.C. 398e; 30 U.S.C. 223, 241, 262, 272, and 282).

For Mineral Leasing Act purposes, the lands between the meander line and the water line of an upland lease described by a meander line adjoining lands beneath navigable waters are unsurveyed lands, as are the lands waterward of the meander line of nonnavigable waters. The survey of these lands for purposes of a mineral lease may include several contiguous leases owned in common but, in conformity with statutory requirements, the survey record will distinguish the several leases and exhibit the boundaries of each.

### *Survey*

**10-81.** The survey shall be made in conformity with the description of the lease. The position of the official survey upon the ground is fixed by connecting it through course and distance to the nearest corner of the public land survey. In a survey embracing two or more leases, each lease will be connected. When the corner tied to is not the nearest record corner, the returns will state that after diligent search no evidence of nearer corner(s) could be found.

**10-82.** As a matter of convenience in the preparation of subsequent descriptions, it is preferable that the corner of each lease from which the connection is made be established as corner No. 1.

From corner No. 1, the successive boundaries of each lease are run in regular manner, numbering the remaining corners in consecutive order. When a boundary line of a lease, including a line connecting opposing meander corners, intersects a section line, give courses and distances from the point of intersection to the corners of the public land surveys at each end of the segment of the line so intersected. When a boundary line of a lease intersects a boundary line of an oil or gas field, give the course and distances from the point of intersection to the corners of the oil or gas field at each end of the segment of the field boundary so intersected. When the corner tied to is not the nearest record corner, the returns will state that after diligent search no evidence of closer corner(s) could be found, or when no record corner in one direction is found, the returns will state that after

diligent search no evidence of corner position(s) could be found.

**10-83.** Mineral leases shall conform to the subdivisions when the area to be selected for a lease is unsurveyed, and a protraction diagram has been approved.

In unsurveyed townships, the latest protraction diagram may be used to describe the boundaries. The local surveyor should coordinate with the cadastral survey section of the appropriate BLM state office, particularly where boundaries are uncertain or unsurveyed. In addition, for mine surveys, at least one vertical monument of the National Spatial Reference System, or equivalent, is tied to, or the geodetic elevation will be directly determined, (Helmert orthometric heights) and referenced to the North American Vertical Datum of 1988 (NAVD 88), or equivalent.

**10-84.** The survey will describe the location of the surface disturbances, surface and underground improvements, and underground workings; their proximity to the nearest lease, ownership, or special use area boundaries in geographical coordinates referenced to the National Reference System (NSRS), North American Datum 1983 (NAD 83), or equivalent; and their location in feet and direction from the nearest two adjacent section, lease, ownership, or special use area boundaries. The authorized officer has the option of approving the use of the Geographic Coordinate Data Base (GCDB) to describe the boundaries, surface disturbances, improvements, or workings when the GCDB coordinates reliability ensures that operations will be within the intended boundaries.

**10-85.** The field notes shall fully and specifically describe every corner. Corners are generally completely described with the first survey line, tie line, or connecting line. Monumentation at any given corner needs to be completely described only once in the field notes.

Corner monuments will consist of the types described in chapter IV. If it is necessary to vary from these instructions, the returns should contain an explanation. If the point for the corner is inaccessible or unsuitable, a witness corner is established. Witness corners are established at a place where the permanency of the monument will not be endangered by water movements, mining activities or other causes. The reason for the establishment of a witness corner should be stated in the field notes.

The position of each corner must be recorded by course and distance to bearing trees, rocks, and other permanent

objects, as prescribed in chapter IV, and when no objects are available the field notes should so state. A magnetic memorial, where practicable, will be deposited at the corner and described in the field notes. The field notes and plats will conform to chapter IX.

## Mine Surveys

**10-86.** These surveys are conducted for three primary purposes:

- (1) Production verification, authorized by the Mineral Leasing Act of 1920 and related acts, administered by the BLM (see regulations at 43 CFR 3482.3 and Subpart 3592).
- (2) Safety, authorized by the Federal Mine Health and Safety Acts of 1969 and 1977, as amended, administered by the Department of Labor, Mine Safety and Health Administration (see regulations at 30 CFR Parts 75 and 77, Subparts M).
- (3) Reclamation, authorized by the Surface Mining Control and Reclamation Act of 1977, as amended, administered by the Office of Surface Mining Reclamation and Enforcement (see regulations at 30 CFR Parts 779, 780, 783, 784, 816, and 817).

**10-87.** For mine survey purposes, “mine” means an underground or surface excavation or series of excavations and the surface or underground support facilities that contribute directly or indirectly to mining, production, preparation, and handling of materials that are severed from the leased lands. Mine surveys are the survey and platting of surface or underground disturbances, operations, improvements, reclamations, and boundaries. Mine surveys produce surface maps, underground maps, or both.

Mine surveys are essential to the planning and safe operation of the mine. They provide data and graphic presentation of information essential to mine rescue. The information is essential to the safe operation of adjacent mines and mines approaching the worked out areas of active or abandoned mines.

**10-88.** Federal mineral leases are typically described by the rectangular system of survey. As with any three-dimensional data initially collected for different purposes, a common frame of reference is critical so the data collected at different times by different surveyors can be readily superimposed.

This class of survey is important in connection with the leasing of mineral lands and compliance with the stipulations of the mineral lease(s) conducted on Federal and acquired lands of the United States and on Indian lands. The field work usually consists of a dependent resurvey and partial subdivision of the section or sections involved, a traverse of the main entries of the mine, with ties to the portals and improvements, and the marking of the section and subdivision-of-section lines within the mine, which divide non-Federal and Federal interest ownership.

**10-89.** A plat showing the subdivisions of the section or sections is prepared with additional diagram(s) added to show the surface disturbances, and the underground and surface workings and improvements of the mine or mines. The diagram(s) should generally be drawn to the same scale as that used on the plat of the mine operations, which is usually 1 inch to 50 or 100 feet, thus permitting a direct comparison. The traverses of the underground workings should be shown by broken lines and the section and surveyed subdivision-of-section boundaries indicated by solid lines.

Mine survey plats must bear, in addition to specific information required by authorized officers, the name and address of the mine, lessee and operator, the lease and mine identification number, the boundary lines of the lease and mine and the name and certificate of the surveyor. The plats must show a scale of the plat, the direction of each line determined with reference to the true meridian as defined by the axis of the earth’s rotation, the horizontal and vertical datum used, the location and description of at least two permanent intervisible horizontal base line points coordinated with the underground and surface measurements, and the location and description of at least two permanent vertical bench marks used in connection with establishing or referencing mine elevation surveys. For new surveys tied to an existing mine survey with a different horizontal or vertical reference than above, the surveyor will show the necessary conversions on the new plat or field notes.

**10-90.** Surveys of new workings, improvements, or surface disturbances will be made when directed by the authorized officer. The new surveys will be extended to show all changes of a permanent character that have taken place during the period between successive surveys. All excavations in each separate bed shall be shown in such a manner that the amount of material that has been severed from the lease can be accurately calculated by comparison of surveys for successive reporting periods.



**10-91.** Before any mine or section of a mine located on or under Federal interest lands is abandoned, closed, or becomes inaccessible, a survey of such mine or section must be made to show conditions at the date of the closure and filed in the official survey record system. Mine surveys must identify those areas of the mine that are inaccessible or cannot be entered safely, and on which no information is available.

**10-92.** Mine surveys are to inform and provide the distance to any boundary of the mine or lease from any surface or underground working, improvement, surface disturbance, or reclamation. Specific requirements for special purpose mine surveys are provided by the authorized officer. Surveyors are reminded to inform themselves what mine survey data is confidential and subject to restricted access.

**10-93.** Surveyors shall comply with all applicable Federal, State, or mine specific safety requirements whenever their work requires entry into surface or underground mines. Entry into an underground mine is only allowed if work is planned and executed in compliance with established BLM safety policy, which regulates how BLM employees may enter an underground mine.

### Mineral Segregation Surveys

**10-94.** A mineral segregation survey is a survey made to define the limits of nonmineral Federal interest land adjoining one or more mining claims and to supply data for lotting the nonmineral land against the claims. Although a necessary part of the survey is to ascertain the boundaries and position of the mining claims, it is not a mineral survey and confers no permanent rights upon the mining claimant. If the subsisting records furnish the information necessary for a proposed segregation of mining claims from the nonmineral Federal interest lands, no mineral segregation survey is required. Prior to the 1947 edition of the Manual, a plat for these surveys was subtitled "Supplemental Plat" (see sections 9-105 through 9-107).

**10-95.** Mineral segregation surveys fall into two classes:

- (1) Where the record of official mineral surveys is faulty or fails to locate the mining claims accurately with respect to the rectangular net. Proper segregation usually requires the resurvey of section boundaries with connections to the mineral surveys.

- (2) Where unsurveyed mining claims require segregation from land embraced in a pending administrative action. The field work consists of surveys of the mining claims, with connections to corners of the rectangular net, and the resurvey of section boundaries.

**10-96.** Where regular conditions are found, the mineral segregation survey consists only in running not less than two connecting lines from identified corners of the rectangular survey to a corner or corners of the mineral location survey, followed by a survey of the outboundaries of the mining claim or group of claims.

Monuments are placed at the angle points or at intersections of mineral location boundaries, between controlling mineral location corners, along the boundary of the mining claim or outboundaries of a group of claims as needed to mark the limits of the nonmineral land. The angle points of the claim are numbered in accordance with the practice in mineral surveys and the intersection points may be marked as witness points. Each monument is marked with the initials of the name of the claim or claims and the angle point number. If the monument at the corner of the mineral location survey is in proper position, constructed of durable material, and suitably marked, the monument may be adopted without any alterations, and its description entered in the field notes.

**10-97.** In townships where there appears to be an extensive obliteration of monuments or where the condition of the lines does not conform to the original plat and field notes, the survey will consist of such retracements and restoration of the corners of the section lines as may be necessary to define the nonmineral land or pending transaction. If the distortion of the section lines is so great as to warrant the subdivision of one or more sections, the work authorized should be described in the special instructions or supplemental special instructions.

**10-98.** The retracement of the lines of the mineral location survey should be made with the same degree of accuracy as a mineral survey. The laws and regulations that govern locating mining claims or sites include provisions for how locations should be described and marked. Therefore, when a surveyor conducts a mineral segregation survey, it is essential that the surveyor observe the requirements regarding the legal length and width of the mining claims, including parallelism of end lines. That is, the surveyor should ensure the claim is confined to the legal length along the mineral lode,



the side lines are placed within the legal width, and the end lines of each claim are parallel. The mining claim, as returned in a mineral segregation survey, should conform to the regulatory specifications for mining claims boundaries. If the mining claim, as returned by the mineral segregation survey, is not identical to (or embraced within) the boundaries of the location survey, the surveyor should give the bearing, distance, and description from each established corner of the mineral segregation survey to the corresponding corner of the location survey.

**10-99.** The rectification of any boundary of unsurveyed mining claims or millsites to meet legal requirements is a complex mixture of mining law, legal principles, policy, and mineral survey judgment. The surveyor cannot change a mineral location boundary outward or in a way that interferes with an intervening right. The Federal authority surveyor conducting the mineral segregation survey under special instructions, typically in concert with the BLM mineral examiner and the Office of the Solicitor, will mark the boundary of the Federal interest lands adjoining the mining claims. The surveyor will examine the history of surveys and titles of all affected claims, alienated lands, and Federal lands to make necessary but lawful adjustments to minimize unmanageable slivers of Federal interest lands.

Because the mineral segregation survey is not a mineral survey, the surveyor does not need to be concerned with potential boundary changes because of changed conditions since the mining claim was located, such as contiguous prior location claims subsequently becoming abandoned or forfeited.

The types of boundary rectification the surveyor is mostly concerned with are parallelism and casting off excess area. The discussion of what is substantial parallelism is in section 10-193. The surveyor is controlled by the record of the location certificate and the markings on the ground. The latter is controlling where there is a variation between the descriptive calls of the record and the monuments (30 U.S.C. 34). For a lode mining claim, if the difference between the location description and the location survey monuments is slight, and casting off excess area is not applicable, the corner with the shortest move distance to obtain parallelism will be moved along the side line and inward.

**10-100.** In cases of casting off excess area, the intent should be to cure defects in the location claim and to put the locator, where no other rights have intervened, in the same position that he or she would have occupied

if no such defect had occurred. Some methods that have been adopted include:

- (1) Where the area to which a location claim can be determined by measurements following the calls for distances from the discovery contained in the location notice, the surveyor may measure out the location and then locate and cast off the excess.
- (2) The location notice specifies the linear distance claimed from the discovery point.
- (3) When the location notice does not specify the linear distance claimed from the discovery point, the locator can only claim 750 feet along the vein on each side of the discovery notice.
- (4) Where the locator mistakes the course of the vein and locates across instead of along it, an excess of lateral side line surface results and should be cast off. The surface rights would be defined by lines drawn 300 feet on each side of the center of the vein as it actually ran. However, a material deviation of the vein from the center line is of no consequence to the Government in a patent proceeding, as long as the claim was located in good faith for mining purposes, and the side lines may exceed 300 feet from the center line on one side in such cases.
- (5) Where a placer claim or millsite is located on unsurveyed land, is in a square or rectangular form, and is oversized, the excess area has to be cast-off; the intent will be to change each boundary inward, by an equal amount, to obtain regularity and legal area.

The locator is entitled to possession of the mining claim as located until he or she readjusts the lines voluntarily or is called upon to do so by the BLM. The locator should be asked to select the portion he or she intends to hold and be afforded a reasonable time to comply. In any case the surveyor will coordinate boundary rectification with the BLM mineral examiner.

In the cases of significant differences between the location certificate and the mineral or location survey monuments, significant corner movement for parallelism, significant excess area, or other complexities, the authorized officer of the BLM will be contacted for further instructions.

## Mineral Surveys

**10-101.** These sections set out the field and office procedure to be followed in the execution of *mineral surveys*, and the filing of the returns. These surveys are made to mark the legal boundaries of mining claims or mill or tunnel sites on the Federal interest lands. In the cases where the boundaries of the mineral surveys are determined by legal subdivisions, survey procedures for the location of such legal subdivisions are identical to those set forth in the proceeding chapters of this Manual.

**10-102.** The early discoveries of free gold were made far in advance of settlement, mainly in the stream beds of the western territories that included the Black Hills, the Rocky Mountains, and the Pacific Slope. Mineral deposits in these regions were appropriated and their values extracted under varied local camp or mining district rules with the tacit approval but without any regulations by the Federal Government.

The functions of a mining district were to provide rules governing the size of claims, manner of location and discovery requirements, recording of location notice, descriptions, and surveys, work required to hold a claim, and period of absence constituting abandonment.

The miners were not without precedents in establishing their rules. In Europe, Germanic or Prussian laws similarly provided for the discovery and location of mineral deposits.

Finally, with the spread and development of the mining industry, Congress adopted legislation not only recognizing the possessory right of citizens of the United States to minerals on public lands but also providing for their disposition. Present procedures are derived from this legislation, which was based in large part on the regulations of the old mining districts.

Today, mining districts exist in name only. As county governments were set up (recording districts in Alaska), the mining districts turned their records over to the county recorders and left the making and enforcement of local mining laws to State or county governments.

**10-103.** Originally, almost all minerals were disposed of through the mining claim location system under the Mining Laws of 1866, 1870, and 1872. Over the years, Congress removed certain minerals from the purview of these Mining Laws. Today, there are three basic ways of appropriating minerals on Federal interest lands through location, lease, and sale. The minerals subject to each

of these methods of disposition have been defined by Federal laws, regulations, policies, and legal decisions, with which the surveyor must gain familiarity.

**10-104.** Mining claims may only be located on Federal lands that are open to the operation of the Mining Law of 1872. When Federal lands are open to the operation of the Mining Law, the Mining Law allows citizens to enter the lands, explore for and discover certain valuable mineral deposits, and purchase the lands containing those deposits. The most significant Federal laws governing mineral lands pertinent to surveying are:

- Lode Law of 1866, as amended (Act of July 26, 1866; 14 Stat. 251), 30 U.S.C. 35, 36, 38, 43, 44 note, 45 note, 46, 47, 51, 52, and 43 U.S.C. 661, covering locatable minerals;
- Placer Law of 1870, as amended (Act of July 9, 1870; 16 Stat. 217), 30 U.S.C. 35, 36, 38, 47, 52, and 43 U.S.C. 661, 766, covering locatable placer claims;
- General Mining Law of 1872, as amended (Act of May 10, 1872; 17 Stat. 91), 30 U.S.C. 22-24, 26-30, 33-35, 37, 39-42, 47, covering locatable minerals;
- Act of May 17, 1884 (23 Stat. 24), as amended by 31 Stat. 321 (June 6, 1900), 48 Stat. 663 (May 4, 1934), 52 Stat. 588 (May 31, 1938), and 61 Stat. 916 (August 8, 1947), found in 30 U.S.C. 49a, 49b, 49c, 49d, extending the Mining Law to Alaska;
- Act of April 28, 1904 (33 Stat. 545), 30 U.S.C. 34, requiring that, if inconsistent, the monumented location will control over the description location;
- Mineral Leasing Act of 1920, as amended (Act of February 25, 1920; 41 Stat. 437), 30 U.S.C. 22, 48, 49, 171, 181-193, 194 note, 201-203, 204 note, 205-214, 221 note, 223-229a, 241, 251, 261-263, withdrawing oil, gas, and other minerals from mining claim location, and disposing of them through leases;
- Materials Act of 1947, as amended (Act of July 31, 1947; 61 Stat. 681), July 23, 1955 (69 Stat. 367), 30 U.S.C. 601, covering saleable minerals;
- Surface Resources Act of 1955 (Act of July 23, 1955; 69 Stat. 367), 30 U.S.C. 601, 603, 611-615, withdrawing common variety mineral materials from mining claim location;

- Millsite Act of March 18, 1960 (74 Stat. 7), 30 U.S.C. 42, authorizing millsites for placer mining claims;
- Federal Land Policy and Management Act of 1976, as amended (Act of October 21, 1976; 90 Stat. 2743), 43 U.S.C. 1732, 1744, amending the Mining Law to impose assessment work filing requirements, an environmental regulation standard, and mandatory requirements that all mining claims, or mill or tunnel sites located on or after October 21, 1976, be recorded within 90 days of their location, and that all mining claims, or mill or tunnel sites located prior to October 21, 1976, be recorded by October 22, 1979, with the proper BLM State Office and maintained according to this law;
- Hardrock Mining Claim Maintenance Fee Act of 1993, as amended (Act of August 10, 1993; 107 Stat. 312, 405), 30 U.S.C. 28f to 28l, establishing an annual per-claim maintenance fee and a one-time location fee for all unpatented mining claims, mill-sites, and tunnel sites.

**10-105.** The Federal mining laws are supplemented by State laws. There are State statutes that govern locating, recording, discovery, and surveying mining claims. Each mineral surveyor should obtain a copy of the State mining laws upon receiving an order for survey in a given State. Mining claimants must comply with State law requirements if those requirements do not conflict with the United States mining laws (*South Dakota v. Madill*, 53 Interior Dec. 195 (1930)). Surveyors may obtain information about State laws and pertinent local regulations from State officials.

**10-106.** The holder of a valid mining claim or millsite is not required to seek patent; a valid unpatented mining claim or millsite remains a fully recognized property right. Under the Mining Law, a mining claimant with a valid mining claim or millsite may seek and, upon satisfaction of the requirements in 30 U.S.C. 29 and all other pertinent laws, obtain a patent, which is a conveyance of full legal title to the claimant. The mineral survey is part of the patent application process. Since 1994, Congress has prohibited the filing of new mineral patent applications.

**10-107.** Mineral patent application surveys, commonly called mineral surveys, are under the direction of the Chief Cadastral Surveyor having jurisdiction within the State in which the mining claim lies.

Special instructions, often called orders, are prepared and issued to the U.S. Mineral Surveyor. Mineral surveys are official surveys. The work that mineral surveyors do is the work of the Federal Government, and the surveys that they make are its surveys (*Waskey v. Hammer*, 223 U.S. 85, 92 (1912)).

When necessary for the orderly administration of the Federal interest land, the BLM conducts a mineral segregation survey (section 10-94). However, such a mineral segregation survey is entirely distinct from a mineral survey, and no permanent rights confer upon the mining claimant as a result of the mineral segregation survey.

### Distinguishing Features of the Mineral Survey

**10-108.** Mineral surveys are required for lode claims and when a placer claim or millsite cannot be conformed to the public land survey or when the land itself is unsurveyed.

Under 30 U.S.C. 35 (Rev. Stat. 2331) “all placer-mining claims located after the 10<sup>th</sup> day of May 1872, shall conform as near as practicable with the United States system of public-land surveys, and the rectangular subdivision of such surveys, and no such location shall include more than twenty acres for each individual claimant.” An “association” placer mining claim may be located by an association of two or more locators, with up to 20 acres each. In other words, two locators may locate a single mining claim up to 40 acres, three locators up to 60 acres, and so on. The statutory limit for an association placer mining claim is 160 acres, which requires a minimum association of eight locators. A company or other business entity is considered a single locator.

Surveys of placer claims are conformed to the legal subdivisions of the public land survey, unless they are located on unsurveyed land or the configuration of the mineral deposit makes conformation impracticable. Consequently, the mineral survey procedures apply especially to lode claims, although those procedures are also followed in appropriate circumstances when surveying placer claims (sections 10-139 and 10-140).

Millsites that embrace nonmineral land not contiguous to the vein or lode and that are occupied for milling purposes or used incidental to mining operations may be located, surveyed, and patented in a manner similar to lode claims. The Act of March 18, 1960 (74 Stat. 7), 30 U.S.C. 42, provides for the location of mill-sites in conjunction with placer claims, and for their

description to be in the same manner as the placer mining claim. State law may require monumentation, even when described by legal subdivisions.

**10-109.** A U.S. mineral surveyor is appointed under the authority of 30 U.S.C. 39, and as such, is included within the term “officers, clerks, and employees” of the BLM as that term is used in 43 U.S.C. 11 and construed in *Waskey v. Hammer*, 223 U.S. 85 (1912). Mineral surveyors are also considered to be special government employees (43 CFR 20. 401(c)(1)(ii)).

The appointment of mineral surveyors, and the renewal, suspension, or revocation of their appointments, is the responsibility of the BLM Chief Cadastral Surveyor. Rules for these administrative procedures and also the procedures for locating, maintaining, and obtaining patent to mining claims and millsites are contained in the Code of Federal Regulations, Title 43, Chapter II, Subchapter C.

**10-110.** The special instructions or mineral survey order for a mineral survey issues from the BLM office administering the Federal interest lands where the mining claim or millsite is located. Estimating the cost of the office work associated with the mineral survey, approving the mineral survey, and refunding any unused funds on deposit is the responsibility of the respective State Office Chief Cadastral Surveyor.

The selection of a particular mineral surveyor from the list of mineral surveyors provided by BLM, payment for his or her services, and the cost of the office work associated with the mineral survey is the responsibility of the claimant.

### Surveyor—Claimant Interrelationships

**10-111.** The mineral surveyor or cadastral surveyor responsible for processing mineral surveys, and the cadastral surveyor when processing mineral segregation surveys, must be thoroughly familiar with both Federal and State laws relating to the appropriation of minerals on Federal lands.

If the location of the mining claim does not meet the requirements set forth by law, the mineral surveyor should advise the mining claimant that corrective steps are necessary, including that it may be necessary for the claimant to amend the location. If the location certificate is too vague, an amended certificate is in order. If corrective measures concerning mining claim location and boundaries are not completed, the surveyor should

then ask the State Office Chief Cadastral Surveyor for further instructions on how to proceed.

As the mineral surveyor is required to prepare the certificate of the value of the improvements (section 10-168), if the development work includes improvements that may not count as patent expenditures or if common improvements may not meet the tests set forth in the regulations, policies, and instructions, the mineral surveyor should bring this to the attention of the mining claimant.

The matter of what constitutes a valid discovery or sufficient mineralization to satisfy the legal requirements for patent is complex and is a matter for the mineral examiner and adjudicators to determine.

### Requirements of Field Work

#### Location Survey

**10-112.** The mineral surveyor and the cadastral surveyor need to be familiar with certain activities that have preceded their involvement with a particular mining claim or site, and upon which their work is dependent, including, but not limited to, the location survey. To be valid, mining claims or sites must satisfy four basic elements, which are (1) discovery of a valuable mineral deposit, (2) proper location, (3) timely recordation, and (4) ongoing maintenance of the mining claim or millsite.

**10-113.** In a group of claims, a discovery of a valuable mineral deposit must be present on each mining claim. If a vein or deposit extends across several claims and the mining claimant has exposed the valuable mineral in the vein or deposit within the limits of each mining claim, then one of the requirements for a discovery is demonstrated for each mining claim.

With respect to a block of contiguous mining claims, located on the same mineral deposit, a valuable mineral deposit exists where the quality and quantity of mineralization on each claim is sufficient to justify a reasonable person in the expenditure of his or her labor and means with a reasonable prospect of success in developing a paying mine. In the case of a group of claims, it is not necessary to show that the deposit on each claim is likely to support a profitable operation were it to be worked by itself. Rather, it may be demonstrated that, were all of the claims to be worked together, sharing the costs of operation, they are likely to support a profitable operation.



**10-114.** The Mining Law, 30 U.S.C. 28 (Rev. Stat. 2324), expressly provides that: “The location must be distinctly marked on the ground so that its boundaries can be readily traced. All records of mining claims made after May 10, 1872, shall contain the name or names of the locators, the date of the location, and such a description of the claim or claims located by reference to some natural object or permanent monument as will identify the claim.” Each location notice or location certificate must include the name or number, or both, of the mining claim or site.

The object of the law in requiring the mining claim location to be marked on the ground is to fix its position and provide notice to other prospectors that the land has been appropriated. It also prevents floating or swinging of the claim, unless amended. Marking the mining claim in this manner, that is performing a location survey, enables those who, in good faith, are looking for unoccupied ground in the vicinity of previous mining claim locations to ascertain exactly what has been appropriated and make their mining claim location on the remainder.

Some States have enacted laws defining the character of monuments or marks to be placed on the ground by the locator. In the absence of such State legislation or local regulation, what constitutes a sufficient marking is determined according to the circumstances in any particular case. The general rule is that the requirement is fulfilled when a person accustomed to tracing the lines of mining claims can, after reading the description of the claim in the posted location notice, by a reasonable and bona fide effort to do so, find all of the monuments or marks, and thereby can retrace all of the lines. It is necessary to mark the locus in a way that the boundary may be readily traced (*United States v. Webb*, 132 IBLA 152 (1995)).

**10-115.** Surveyors must comply strictly with the provisions of law regarding location, recording, and maintenance because of the importance of a mineral survey in the patenting process. If the surveyor is able to ascertain that the mining claimant has not complied with location, recording, or maintenance requirements, the surveyor must decline to make the mineral survey and report the facts to the respective State Office Chief Cadastral Surveyor for further instruction (*Philip Dephanger*, 1 Pub. Lands Dec. 581 (1882)).

The location survey is typically done by or under the supervision of the mining claimant. Even when the location survey happens to have been performed by the

mineral surveyor, such survey cannot be substituted for the actual mineral survey.

The difficulties surrounding the location and location survey frequently render it impossible to accurately mark the location boundary. The locator is generally permitted to rectify and readjust the location boundaries, if it can be done without impairing the intervening rights of others. The rectification of such boundaries is often handled by a second location survey, and the recording of an amended location notice, prior to applying for an order for mineral survey.

**10-116.** In lode mining claim adverse proceedings, it has been found that a locator should not be permitted to hold an excess of ground, and subsequent locators may be governed by the statement in the notice and not by monuments and marks that include and excess of surface ground within their boundary.

For placer mining claims and millsites containing excess area, the rule is that the locator must not be deprived of the right to select the part of the mining claim or mill-site that is to be cast off. This right of selection is to be exercised within a reasonable time after the locator has been notified that the location as marked on the ground is excessive.

In the case of placer mining claims and millsites located by legal subdivisions, and containing excess area by more than the rule of approximation (section 10-197), the excess would have to be cast off by survey. If, however, the excess is negligible, the locations would be permitted.

**10-117.** There is a distinction between amending an original location claim by moving boundaries and rectifying errors, and the inclusion of new ground or the relocation of abandoned ground. The amendment, if properly made and no other rights have intervened, takes effect back to the date of the original location claims, whereas the relocation becomes operative only from the date of the new location claim or relocation.

### *Mineral Patent Application Survey*

**10-118.** The mineral survey is performed after recordation of the location notice or amended location notice as required by State law. It must be completed and officially filed before filing the patent application. The survey includes the usual technical procedure of permanently monumenting and witnessing the location on the ground, identifying all conflicts with prior mineral surveys, fee



lands with or without Federal mineral interests, lands withdrawn from mineral entry, and prior locations that the mining claimant wishes to exclude. Also included is the examination required for preparing affidavits of the value of expenditures for development purposes and any other reports to be made by the mineral surveyor. The survey itself does not confer legal title; legal title is conveyed by the final certificate and patent.

**10-119.** The duties of the mineral surveyor begin with special instructions or an order for survey and cease with the expiration of the period of publication of the mineral patent survey. After receipt of the special instructions or survey order, the mineral surveyor should obtain, among other items, copies of:

- (1) the relevant legal descriptions of the mining claim and of the surrounding mining claims documented in the location and amended location certificate(s), contest file(s), quiet title action judgment roll(s), or mining claim recordation file(s), adverse proceedings judgment roll(s), or patent file(s), final certificates, and patents;
- (2) relevant survey information of the mining claim and of the surrounding land, including official public land and mineral land surveys, canceled mineral surveys, mining claim location maps or diagrams, plats or maps included in contests, quiet title actions or adverse proceedings, and local surveys;
- (3) Federal and non-Federal land ownership and mineral status records;
- (4) Federal survey records such as National Forest Homestead Entry Surveys, General Forest Exchange Surveys and Small Tract Surveys on National Forest System Lands, Small Holding Claims, Small Tracts, Townsites, U.S. Surveys, Rights-of-Way and withdrawals, special use areas, etc.;
- (5) the reports as to the condition of corners and survey discrepancies contained within other corner descriptions and supplemental data of approved mineral surveys; and
- (6) connecting sheets, if available, that show in outline all approved mineral surveys, which should be examined for conflicts with prior mineral surveys. The BLM record of unsurveyed locations should also be searched.

**10-120.** The mineral survey must be an actual survey on the ground, made by the mineral surveyor in person after the receipt of the order. It must be made without reference to or reliance upon any knowledge previously acquired by having made the location survey or otherwise. The record must show the actual facts existing at the time of the survey. This precludes a calculation of the connections to corners of the public land survey and to mineral or location monuments, or of any other lines of the survey, through prior surveys, unless it is satisfactorily shown in the report that he or she has retraced such lines and found them to be correct as approved and filed (*Veta Grande Lode*, 6 Pub. Lands Dec. 718 (1888); *Lincoln Placer*, 7 Pub. Lands Dec. 81 (1888); *Walter Bartol*, 19 IBLA 82 (1975)).

The survey may include several contiguous locations owned in common, but such survey must, in conformity with statutory requirements, distinguish the several locations and exhibit the boundaries of each (*S.F. Mackie*, 5 Pub. Lands Dec. 199 (1886); *Golden Sun Mining Co.*, 6 Pub. Lands Dec. 808 (1888); *Argillite Ornamental Stone Co.*, 29 Pub. Lands Dec. 585 (1900)).

**10-121.** The patenting provisions of the Mining Law, 30 U.S.C. 29 (Rev. Stat. 2325), expressly provide that the mineral survey shall show the boundaries of the claim or claims, which, pursuant to 30 U.S.C. 28, the claimant should have distinctly marked by monuments on the ground with reference to natural objects or permanent monuments as will identify the claim(s).

Lengths of lines are returned as their true horizontal equivalents in the *foot unit* (U.S. Survey Foot). The degree of accuracy required in making mineral surveys calls for careful use of all direct or indirect measuring devices. These measuring devices should be compared to a known base line prior to commencing the survey.

Mineral surveys must be made with an instrument by which the meridian may be determined independently of the magnetic needle, and the directions of lines must be referred to the true meridian. The true course of at least one line of each survey is to be ascertained at the time of the survey through the use of satellite based geodetic positioning system, by observation of the sun, Polaris, an equatorial star, or equivalent, with proper verification of the time and latitude.

The direction of each line is reported in bearings. Bearings are stated in terms of angular measure referred to the true meridian. The basis for reporting directions is called mean bearing referenced to the true meridian

at the point of record (sections 2-3 and 2-5). The methods employed and the results are recorded in the field notes of the survey. The mean magnetic declination of the survey, when observed, is to be recorded in the field notes. Specimen field notes of a mineral survey will be found in appendix III.

**10-122.** For lines of any east-west extent, the true meridians passing through each end point of the line are not parallel, and thus, the basis of bearing is not orthogonal with reference to a plane surface (section 2-11). Therefore, reference meridians are not parallel but converge towards the pole, and parallel lines, in mineral surveys, are two lines a constant distance apart, such as the end lines of a lode claim. Thus, parallel lines that are not true east and west will have different bearings (section 10-193).

**10-123.** The survey must be made in strict conformity with, or be embraced within, the lines of the location survey upon which the order is based. If the lands to be surveyed and the location survey are identical, the field notes will clearly state that fact and the description of the corners of the location survey entered in the field notes. If not identical, a bearing, distance, and description of the corners of the location survey are to be given in the field notes from each established corner of the survey to the corresponding corner of the location. The lines of the location as found upon the ground should be laid down upon the preliminary plat only in such manner as to contrast and show their relation to the lines of survey (*Philip Dephanger*, 1 Pub. Lands Dec. 581 (1882)).

**10-124.** The mineral survey is given a single number. A location claim under the mining laws can legally be made only of a tract or piece of land embraced within one set of boundary lines. Two or more tracts merely cornering with each other cannot legally be embraced in a single location claim (*Tomera Placer Claim*, 33 Pub. Lands Dec. 560 (1905); *Hidden Treasure Mine*, 35 Pub. Lands Dec. 485 (1907)). An owner of several unpatented mining claims who has received patent for certain contiguous mining claims in the group may apply for patent to the remainder in one application, even though the unpatented claims are not contiguous to each other, if each is contiguous to the body of land embraced in the patented claims (*Wagner Assets Realization Corp.*, 53 Interior Dec. 614 (1932)).

**10-125.** In accordance with the principle that courses and distances must give way when in conflict with fixed objects and monuments, the mineral surveyor may not change the corners of the location survey for the

purpose of making them conform to the description in the record. If the difference from the location certificate is slight, it may be explained in the field notes.

**10-126.** If after having obtained an order for survey the surveyor finds that the record of location does not practically describe the location as marked upon the ground, the applicant should file a certified copy of an amended location certificate, correctly describing the claim, and obtain an amended order for survey. In fact, any change in the original order including the addition or dropping of locations or designation of a different surveyor calls for an amended survey order.

**10-127.** If the mining claim or site to be surveyed was located prior to May 10, 1872 (see 30 U.S.C. 22-24, 26-30, 33-35, 37, 39-42, 47; Rev. Stat. 2319-2328, 2331), the mineral surveyor is governed by the special instructions accompanying the order for survey.

**10-128.** No lode claim located subsequent to May 10, 1872, shall exceed the statutory limit of 300 feet in width on each side of the center of the vein, or 1,500 feet in length. All surveys must close within 0.25 feet in 1,000 feet, and the error must not be such as to make the mining claim exceed the statutory limit. Stricter limits of closure will be specified in the survey order where higher precision is indicated by the values involved. No placer claim may exceed 20 acres for each locator up to the statutory limit of 160 acres in an association placer claim, and millsites may not exceed 5 acres. The per-claim limit of 20 acres for each placer claim locator and the 5-acre limit for each mill-site will be governed by the rule of approximation (section 10-197).

**10-129.** Corner No. 1 of each claim and site will be tied to a section or quarter section corner or a corner of record. If a corner of the PLSS cannot be recovered or if the township is unsurveyed, corner No. 1 of each mining claim or site will be tied to a permanent monument. The geographic position of the mineral survey will be determined by a tie to a geodetic monument or determined directly.

#### ***Lode Lines and End Lines***

**10-130.** In the absence of proof to the contrary, the discovery point is held to be the center of the vein on the surface. In the case of a mineral deposit that is not in vein or lode form, the discovery point is presumed to lie at the center of the lode mining claim. The course and length of the lode line or presumed course of the vein

will be marked upon the plat and specifically described in the field notes. The record of the intersections of the end lines with the lode line are given in the field notes from the lowest numbered corner on each end line running toward the next higher numbered corner. Where conditions permit, the distances are shown on the plat.

**10-131.** In a mineral survey, slight variation from the lines as originally located is acceptable. The surveyor may draw in the end lines to make them parallel and is permitted to cast off the area in excess of the statutory limit. The requirement of the statute as to end line parallelism is satisfied with a reasonable compliance. Substantial parallelism is acceptable.

It was held in *Belligerent and Other Lode Mining Claims*, 35 Pub. Lands Dec. 22 (1906), (syllabus), that:

There is no warrant in the mining laws for extending, arbitrarily and without any basis of fact therefor, the vein or lode line of a location in an irregular and zigzag manner for the purpose of controlling the length or situation of the exterior lines of the location to suit the convenience, real or imagined, of the locator.

The end lines of a lode location must be straight and parallel to each other, and when at right angles with the side lines may not exceed six hundred feet in length.

The mining laws contemplate that the end lines of a lode claim shall have substantial existence in fact, and in length shall reasonably comport with the width of the claim as located.

**10-132.** Except in jurisdictions where State law requires differently, in the case of blanket veins that are essentially horizontal or mineral deposits where the valuable mineral is in disseminated form, a presumed lode line or center line need not be shown, and the discovery working may be anywhere on the mining claim. In such cases, the tie to the discovery point should be given from the nearest corner of the survey and included in the description of that corner, or a right angle tie may be given from a point on the nearest end line. For such claims the centerline is considered to be equidistant between the sidelines.

For horizontal or disseminated mineral deposits, if a subsurface point where a hole drilled on an angle intersects the ore body is designated as the discovery point, such point will be tied to the surface hole by bearing and

distance, and the tie to the surface hole should be given from the nearest corner of the survey. The description of the hole will include the vertical angle and the slope distance. The description of the drill hole will include the direction drilled, the dip angle as measured from the horizontal, and the downhole slope distance as drilled.

### Method and Order of Procedure

**10-133.** The position of the official survey upon the ground is fixed by connecting it by course and distance either to the nearest corner of the public land survey, or to a mineral monument (section 10-152). In either case the connecting line may not exceed a length of 2 miles. If both a corner of the public land survey and a mineral monument are within the limiting distance, the connection should be made to the public land survey corner. Each location claim of a survey embracing two or more location claims must be so connected.

When a mining claim is situated within the limits of a township the survey of which is in good standing, but where no corner of the survey can be found within 2 miles of the claim, after diligent search, connection may be made with a mineral monument, which must be connected with an established public land survey corner. The full particulars must be described in the field notes.

As a matter of convenience in the preparation of subsequent metes-and-bounds descriptions, it is preferable that the corner of each location from which the connection is made be established as corner No. 1.

The three preceding paragraphs are intended to permit the surveyor to obtain connections in a practicable manner based upon existing field conditions. Any unusual conditions that may be encountered in obtaining connections should be explained in the field notes. When the corner tied to is not the nearest record corner, the field notes will state that it is the nearest corner that could be found after diligent search.

**10-134.** From corner No. 1 the successive boundaries of each location are run in regular manner, numbering the remaining corners in consecutive order. When a boundary line of a mining claim or millsite intersects a section line, give courses and distances from the point of intersection to the corners of the public land survey at each end of the segment of section line so intersected. When the corners tied to do not include the nearest record corner, or when a record corner in one direction is not found, the field notes will state that, after diligent

search, no evidence of nearer corner position(s) could be found.

**10-135.** A lode or placer claim, and a millsite embraced in one survey are distinguished by the letters A and B, respectively, following the number of the survey. The corners of the millsite are numbered independently of those of the lode or placer. A corner of the millsite, preferably corner No. 1, is connected with the nearest corner of the public land survey or mineral monument, and a corner of the millsite is connected with a corner of the lode or placer claim.

**10-136.** When a placer claim includes one or more lodes, or when several contiguous placer or lode locations are included as one claim in one survey, the corners of each location are given a separate consecutive numerical designation, beginning with corner No. 1 in each case. The placer claim should be described in the field notes before describing the lodes.

When a placer claim includes one or more lodes, and the lode is claimed by the placer claimant, the lode claims will be surveyed in the same manner as if they were elsewhere situated, although the plats of the placer and lode surveys may be combined and constitute but one plat.

**10-137.** In all cases, whether the lode is claimed or excluded, the lode(s) and invaded legal subdivisions must be surveyed and marked upon the plat. The field notes and plat are to indicate the area of the lode and the area of the placer separately.

**10-138.** In the case of a subsequently located lode claim within an existing placer claim, the extent of surface ground may be the minimum, i.e., 25 feet on each side of the vein unless the lode is less than 25 feet from the nearest boundary of the placer. The 25-foot rule applies whether the placer is owned by the applicant or a third party.

**10-139.** Nonrectangular placers are permissible where use of a description by legal subdivisions would result in conflicts with other mining claims. In such cases, the placer claim must be surveyed around existing claims, so that no conflict is created.

**10-140.** Placer claims that do not conform to the legal subdivisions of the public land survey require a mineral survey. When such claims are on unsurveyed land, they should be conformed as nearly as practicable to the protraction diagram.

**10-141.** For nonrectangular placer mining claims and millsites, in applying the 10-acre rule for placers or the 2½-acre rule for millsites, each claim or site must be subdivided along the axis in which it was laid out on the ground. The 10-acre rule for placer claims or the 2½-acre rule for millsites is properly applied by subdividing a claim or site into lots as nearly square as possible (*United States v. Lara (On Reconsideration)*, 80 IBLA 215 (1984), *aff'd.*, *Lara v. Secretary of the Interior*, 820 F.2d 1535 (9<sup>th</sup> Cir. 1987)).

If the placer claims consist of a bench or gulch placer, they must be contained within the required number of 40-acre legal subdivisions, according to the rules given in *Snow Flake Fraction Placer*, 37 Pub. Lands Dec. 250 (1908); 43 C.F.R. 3832.12(c)(3).

**10-142.** If a mineral examination determines that certain portions of a nonrectangular placer claim or millsite do not qualify for a patent, then the following procedures must be applied to subdivide the placer claim or millsite per *United States v. Lara (On Reconsideration)*, 80 IBLA 215 (1984), *aff'd.*, *Lara v. Secretary of the Interior*, 820 F.2d 1535 (9<sup>th</sup> Cir. 1987):

Where the placer claim is in a rectangular form, and a portion of it is found to be nonmineral in character, then the claim must be subdivided to exclude the nonmineral land. The mineral examiner will establish a baseline and, along the long axis of the claim, mark off 10-acre parcels perpendicular to the long axis. The surveyor will then subdivide the claim pursuant to the mineral examiner's map and report.

Where the millsite is in a rectangular form, and a portion of it is not being used or occupied for mining or mineral purposes, then the millsite must be subdivided to exclude the unused or unoccupied land. The mineral examiner will establish a baseline and, along the long axis of the millsite, mark off 2½-acre parcels perpendicular to the long axis. The surveyor will then subdivide the millsite pursuant to the mineral examiner's map and report.

If the placer claim or millsite is in square form, the surveyor will then subdivide the placer claim or millsite pursuant to the mineral examiner's map and report.

**10-143.** The field notes of a placer claim must contain a descriptive report describing:



- (1) the quality and composition of the soil;
- (2) the character, extent, and position of all surface and underground workings for mining purposes;
- (3) the proximity of centers of trade or residence;
- (4) the proximity of well known systems of lode deposits or of individual lodes;
- (5) the use or adaptability of the claim for placer mining, including the availability of water in sufficient quantity for practical operations. Streams should be fully described as to their course, amount of water carried, and the vertical drop in elevation of the stream within the claim;
- (6) works or expenditures made by the claimant or his or her grantors for the development of the claim;
- (7) the true position of all known mines, salt licks, salt springs, and millsites. When none is known to exist on the claim, that fact will be so stated;
- (8) the natural features of the claim; and
- (9) the kind and amount of timber and other vegetation thereon, and adaptability to mining or other uses.

In the case of placer claims taken by legal subdivisions, no such descriptive report by a mineral surveyor is required.

### Conflicts

**10-144.** When an exterior line of a claim intersects the surveyed line of another claim, the field notes must show (1) the distance to the point of intersection and (2) the course and distances from the point of intersection along the intersected line of the conflicting claim to the corners at the endpoints of the intersected line. When the same line of a conflict is intersected by two lines of the survey being executed, the tie is given to the opposite corner of the conflicting survey at each point of intersection.

It is necessary to search diligently for each corner controlling a line in conflict. If the necessary corners cannot be found, the boundaries shall be reestablished.

**10-145.** When the lines of two locations of the survey intersect, the point of intersection is given on the line being described, including the course and distances along the intersected line to the nearest corners.

**10-146.** Conflicts with unsurveyed locations may not be reported unless it is the wish of the claimant to exclude them from the area claimed.

If there are prior locations, it may be well to report conflicts in order to avoid an adverse suit. Conflicts with unsurveyed locations, owned by the claimant and not a part of the survey, need not be shown nor excluded unless the area of conflict contains the discovery of the unsurveyed location. In cases where two claims of the survey are in conflict, the area of conflict may not contain both discovery points.

**10-147.** Surveyed claims owned by the applicant that are in conflict with or contiguous to the survey being executed must be reported in the field notes.

**10-148.** If surface fee lands are in conflict as to boundary, whether or not the mineral estate was reserved to the United States, a subdivision of the section(s) should be done. Special surveys such as town-sites, Forest Homestead Entry Surveys and, in Alaska, U.S. Surveys and Coal Surveys are treated as prior mineral surveys.

**10-149.** A connecting line should be run from a corner of the survey to a corner of each conflicting survey and to a corner of each conflicting unsurveyed location to be excluded, unless a connection can be identified by virtue of intersect ties developed during the survey.

**10-150.** Connection is also made to any survey, the record position of which is within 100 feet of the lines of the survey being executed; also to any other neighboring survey, the position of which is not definitely fixed by the record. Such connections should be made and conflicts shown according to the boundaries of the neighboring or conflicting claims as each is marked, defined, and actually established upon the ground.

**10-151.** The field notes must fully and specifically state how and by what visible evidence the several conflicting surveys were identified on the ground, as well as those that appear to conflict, according to their returned tie or boundary lines, and report all material errors or discrepancies found in such surveys. In the survey of a group of contiguous claims where any corner is common to two or more claims of the group, bearings should be mentioned but once, and such corner should be described



as a common corner in the claim first mentioned in the field notes.

### Mineral Monuments

**10-152.** In previous practice, if a survey was situated in a district where there were no public land survey corners and no mineral or location monuments within 2 miles, a mineral or location monument was established. The site, when practicable, was to be some prominent point, visible from every direction, where the permanency of the monument would not be endangered by snow, rock, or land movements or other natural causes. The geographic position of the monument, determined as accurately as the known data and the instruments used would permit, was recorded in the field notes.

However, in subsequent surveys the current geographic position of the mineral monument will be determined within a positional tolerance defined by the office issuing the special instructions or mineral order.

There was a period of time when such monuments were called “Location Monuments” and were designated “USLM.”

**10-153.** In the event a mineral monument is to be established the mineral monument should consist of a regulation post similar to the type used for rectangular surveys, set three-fourths of its length in the ground, with a magnetic memorial beneath, and with a conical mound of stone 4 feet high and having a 6-foot base alongside. The letters “USMM” followed by the number of the survey are marked on the brass cap. The exact reference point is indicated on the top of the monument by a cross. Any necessary departure from the prescribed material and size of monument is to be explained in the returns.

**10-154.** From the monument the precise course and distance is to be taken to two or more bearing trees or rocks, and to any well-known and permanent objects in the vicinity, such as buildings, shafts, mouths of adits, prominent rocks, or the confluence of streams. Bearing trees are scribed “XBT” and the bearing rocks chiseled “XBO” together with the number of the mineral monument. A detailed description of the mineral monument, including its geographic position, approximate distance, and direction to the nearest town, is to be furnished in the record of the survey.

### Corner Monuments

**10-155.** Corner monuments will consist of the types described in chapter IV. If it is necessary to vary

from these instructions, the returns should contain an explanation.

The field notes shall fully and specifically describe every corner monument. These are generally completely described on the first survey line, tie line, or connecting line. The monument at any given corner needs to be completely described only once in the field notes.

All corners must be monumented in a permanent and workmanlike manner, constructed as prescribed in sections 4-11 through 4-15. The distinguishing initial letter or letters, corner numbers, and survey numbers will be stamped on the cap of the monument. The precise corner point is permanently indicated on the monument. When a rock in place is used, its dimensions above ground should be stated, and a brass tablet set at the corner point. If a brass tablet at the corner point is impracticable, a cross should be chiseled at the corner point and a reference monument set. Corners common to two or more locations are marked with the initial letter and corner number of each location.

**10-156.** In case the point for the corner is inaccessible or unsuitable, a witness corner is established, which will bear the letters “WC” in addition to the regular markings. When practicable the witness corner should be located as near as possible to the true corner point, with which it must be connected by course and distance. The reason for the establishment of a witness corner should be stated in the field notes (sections 4-16 and 6-27).

**10-157.** The position of each corner will be recorded by course and distance to bearing trees, rocks, and other permanent objects, as prescribed in chapter IV, and when no objects are available the field notes should so state. A magnetic memorial, if practicable, should be deposited at the corner and described in the field notes.

**10-158.** In contrast to the method of measuring the distance to bearing trees of the public land survey corners (to the center of the tree at its root crown), the distance is taken to the point indicated by a scribed X located immediately above the scribe marks BT. If the distance is taken to a point other than the X then the field notes will state the point to which the distance is measured.

### Topography

**10-159.** The topographic features of mining claims and millsites should be noted carefully. Distances on the lines are shown to intersections with significant streams, gulches, ditches, ravines, roads, trails, etc., with their

widths, courses, and other data required for mapping. If the claim or site lies within a townsite, all important municipal improvements, and the street and block system within the claim or site should also be located for mapping purposes.

### Field Notes and Preliminary Plat

**10-160.** Field notes and other reports must be upon the proper forms and/or in the proper format, which are furnished with the order for survey or upon application. No interlineations or erasures are permissible, and no abbreviations or symbols may be used excepting those shown in section 9-20 and as employed in the specimen mineral survey field notes in appendix III.

**10-161.** The mineral surveyor prepares and files a preliminary plat, drawn on a scale of 200 feet to an inch, if practicable, in conformity with specimen plat no. 4, the lines of the claim surveyed being shown heavier in contrast with conflicting claims. The geographic position of a corner of the survey will also be furnished (see section 9-103). It should clearly state that it is a "PRELIMINARY PLAT SUBJECT TO CORRECTION."

**10-162.** In order that the results of the survey may be reported in a uniform manner, the field notes and preliminary plat are to be prepared in strict conformity with the specimen field notes and plat. These are designed to furnish all needed information concerning the manner of describing the boundaries, corners, lode lines, connections, intersections, conflicts, and improvements, and of stating the geographic position, magnetic declination, area, location, and other data connected with the survey of mineral claims, and to prescribe certain forms of certificates for the surveyor, and for listing his or her assistants.

**10-163.** Throughout the description of the survey, after each reference to the lines or corners of a claim or site location, give the name thereof, and if unsurveyed, state the fact. If reference is made to a claim or site location included in a prior official survey, the survey number is given, followed by the name of the claim or site.

**10-164.** The total area of each mining claim or mill-site in a group embraced by its exterior boundaries, and also the area in conflict with each intersecting survey or claim, will be stated. When mining claims or mill-sites of the survey conflict with each other, such conflicts should be stated only in connection with the mining claim or millsite from which the conflicting area is excluded.

**10-165.** The field notes and plat of survey should not show exclusions, or attempt to specify the net area of the claim. These are matters for the applicant to state in connection with an application for patent, and the notices posted and published. The field notes should merely show the total and net areas of conflict, so that any exclusion desired may be made readily.

**10-166.** The field notes will state specifically whether the claim is upon surveyed or unsurveyed Federal lands, giving in the former case the quarter-quarter-section, township, range, meridian, and state in which it is located, and in the latter the township and range as nearly as can be determined by the protraction diagram or, if not protracted, the information at hand. When upon surveyed lands, the section boundaries should be indicated by full lines and protracted legal subdivision boundaries by broken lines.

**10-167.** The title page should contain the mailing address of the claimant or authorized agent.

### Improvements

**10-168.** In 30 U.S.C. 29 (Rev. Stat. 2325), it is directed that at least \$500 shall be expended upon a mining claim as a prerequisite to obtaining a patent.

In preparing the certificate of the value of the improvements, the form shown in the specimen mineral survey field notes in appendix III is followed.

Only actual expenditures and mining improvements made by the patent applicant or the applicant's grantors, and having a direct relation to the development of the claim, are to be included in the estimate. The expenditures required may be made on the surface or in running a tunnel, drifts, crosscuts, or drill holes for the development of the claim. Improvements of any other character, such as buildings, machinery, or roadways are excluded from the estimate unless it is clearly shown that they are associated with actual excavations, such as cuts, tunnels, and shafts, and are essential to the practical development and to actually facilitate the extraction of mineral. Mills for ore treatment, or roadways, tramways, or trails built for transporting the extracted ore from the mine, are not to be included in the estimate.

**10-169.** All mining and other improvements on the claim are located by course and distance from corners of the survey, or from points on the indicated lode line, specifying with particularity the dimensions and character of each. The improvements upon each location

should be numbered consecutively, the point of discovery always being No. 1. Improvements such as cabins, ore bins, roads, bridges, etc., that do not develop the claim and improvements made by a former locator who has abandoned the claim are not to be included in the estimate but should be described by separate statement in the field notes and shown on the plat.

The field notes should show in detail the value of all improvements included in the estimate of expenditures. When a tunnel or other improvement has been made for the development of other claims in connection with the one for which survey is made, the name, ownership, and survey number, if any, of each claim to be credited, and the value of the interest credited to each should be stated.

**10-170.** When a lode or placer claim, and millsite are included in the same survey, an expenditure of \$500 at the time of application for patent is required upon the lode or placer claim only.

**10-171.** When a survey embraces several mining claims held in common, constituting one contiguous block of mining claims, whether lode or placer, an expenditure of \$500 at the time of application for patent for each mining claim embraced in the group is required.

**10-172.** The Secretary's decision in *James Carretto and Other Lode Claims*, 35 Pub. Lands Dec. 361 (1907) (syllabus), has been summarized as follows:

Where several contiguous mining claims are held in common and expenditures are made upon an improvement intended to aid in the common development of all of the claims so held, and which is of such character as to redound to the benefit of all, such improvement is properly called a common improvement.

Each of a group of contiguous mining claims held in common and developed by a common improvement has an equal, undivided interest in such improvement, which is to be determined by a calculation based upon the number of claims in the group and the value of the common improvement.

There is no authority in law for an unequal assignment of credits out of the cost of an improvement made for the common benefit of a number of mining claims, or the apportionment of a physical segment of an improvement of

that character to any particular claim or claims of the number, such an arbitrary adjustment of credits, as the exigencies of the case may seem to require, being utterly at variance with the essential idea inherent in the term a common improvement.

In any patent proceedings where a part of a group of mining claims is applied for and reliance is had upon a common improvement, the land department should be fully advised as to the total number of claims embraced in the group, as to their ownership, and as to their relative situations, properly delineated upon an authenticated map or diagram. Such information should always be furnished in connection with the first proceeding involving an application of credit from the common improvement, and should be referred to and properly supplemented in each subsequent patent application in which a like credit is sought to be applied.

**10-173.** The Deputy Solicitor's decision in *United States v. Smith*, 66 Interior Dec. 169 (1959) (syllabus), has been summarized as follows:

While it is permissible to allocate among a group of contiguous claims the value of improvements placed on one of the claims in the group, this can only be done where there is a showing that the labor performed or the improvements made on that claim were intended to aid in the development of all the claims and that the labor and improvements are of such a character as to redound to the benefit of all.

**10-174.** The IBLA's decision in *Brattain Contractors, Inc.*, 37 IBLA 233 (1978) (syllabus), for common off-site improvements, has been summarized as follows:

Where in a patent application for a group of claims, prorate credit for the value of a common, off-site improvement is to be attributed to each claim, it must be shown that the improvement was subsequent to the location of each claim so credited, and that the improvement is essential to the practical development and actually facilitates the extraction of ore from each claim.

The explanatory statement in such cases should be given in the field notes or affidavit at the conclusion of the description of the improvements included in

the estimate of expenditure, and should be as full and explicit as the facts in the case warrant, dealing only with improvements, conditions, and circumstances as they actually existed at the time of survey or subsequent field examination.

**10-175.** If the value of the improvements upon a mining claim is less than \$500 at the time of survey, authority is given to file thereafter supplemental proof showing \$500 expenditure made prior to the expiration of the period of publication for patent. The information on which to base this proof must be derived by the mineral surveyor, who makes the actual survey, from a careful examination upon the premises.

**10-176.** Only improvements made by the patent applicant or the applicant's grantors subsequent to the location of the claim are counted under the statutes toward patent expenditure. The BLM Cadastral Survey Office certifies to this fact according to the record, and, as the certificate is based on the report of the mineral surveyor, the latter should exercise special care to see that only such improvements are reported.

**10-177.** The expenditure for the mineral survey may not be accredited as labor or improvement as a prerequisite to patent, nor as annual assessment work upon the claim (*Cost of Official Survey of a Mining Claim Not Acceptable as Annual Assessment Work*, 52 Pub. Lands Dec. 561 (1929)).

### Millsite

**10-178.** A millsite may be dependent, encompassing nonmineral land not contiguous to a vein or lode, if used or occupied by the owner of the vein or lode for mining or milling purposes as of the date of the BLM mineral examination or withdrawal, whichever is earlier. The millsite may be independent, encompassing "a quartz mill or reduction works" (30 U.S.C. 42(a)), if not dependent on a particular mining claim and the owner not necessarily the owner or claimant of a claim. A millsite claim may also encompass nonmineral land used or occupied by the owner of a placer deposit for mining or milling purposes (30 U.S.C. 42(b)).

**10-179.** The maximum size of each individual millsite is 5 acres, governed by the rule of approximation (section 10-197). Only that amount of millsite acreage that is reasonably necessary to be used or occupied for efficient and reasonably compact mining or milling operations is locatable (43 CFR 2832.32). Each 2½-acre portion of a millsite must be used or occupied in order for

that portion of the millsite to be valid (43 CFR 3832.33 (a)(2)).

All improvements and projected improvements should be shown. If the ground is to be used for a tailings or evaporation pond, the dam should be shown with its ultimate height and the high water line of the pond delineated by the survey.

### Amended Orders

**10-180.** An amended (supplemental) order is based on an amended application from the claimant. It is usually occasioned by the filing of amended location certificates. The amended application is processed exactly the same as the original application.

If amended location certificates are filed for record, it will be necessary to make an amended application for survey based on the amended certificates, and receive an amended order for survey.

An amended order is also called for if there is an addition or deletion of claims from the survey.

A change in mineral surveyor will call for an amended order, and the order to the original mineral surveyor must be cancelled.

If the claimant sells the claims, an amended order will be required to show the new claimant.

An amended order may be used to authorize the survey of additional expenditures if the survey was approved without the necessary expenditures made.

An amended location notice prior to applying for an order for patent survey can be used when it is found necessary to change location claim boundaries.

### Amended Surveys

**10-181.** Amended surveys are ordered in the same manner as original mineral surveys. The conditions and circumstances peculiar to each separate case and the object sought by the required amendment are set forth in the special instructions, order, or amended order, and alone govern all special matters relative to the manner of making such surveys and the form and subject matter to be embraced in the field notes.

**10-182.** An amended survey must be made in strict conformity with, or be embraced within, the lines of the



original survey. If a portion of the amended and original surveys is identical, that fact must be distinctly stated in the field notes. If not identical, the bearing and distance are given from each established corner of the amended survey to the corresponding corner of the original survey. The lines of the original survey, as found upon the ground, are laid down upon the preliminary plat in such manner as to contrast and show their relation to the lines of the amended survey.

**10-183.** The field notes of the amended survey are prepared on the same size and same forms as are required for the field notes of the original survey, and the abbreviation “Am.” will be used after the survey number wherever it occurs.

**10-184.** A new mineral survey is required if the claim boundaries are changed by amendment after the original survey is approved. A new survey is also required where the claim has been abandoned and relocated by another.

### Cancellation of Mineral Surveys

**10-185.** A mineral survey may be cancelled only after the claim has been relinquished by the claimant, declared forfeited, or determined null and void. It can be cancelled only by the BLM Chief Cadastral Surveyor authorized to approve mineral surveys within the administrative jurisdiction.

When it becomes necessary to cancel a mineral survey, the plat is clearly marked “Canceled” but is not removed from the official records. No notations are made on the field notes. The survey corner monuments normally are not removed. Monuments should be removed only for clearly advantageous reasons and only in connection with an official survey where the positions of the old monuments are tied in before destruction.

If the mineral survey is canceled, it is still available for other uses. If the mineral survey and corner monuments could be used for future disposal or administrative purposes, they are incorporated in an official survey or supplemental plat. This is done by assigning lot numbers to the area within the canceled mineral survey. Where the survey is retained, the field notes of the canceled survey may become the basis for the new lot designation and support the new plat.

### Tunnel Sites

**10-186.** A tunnel site is a subsurface right-of-way under Federal land open to mineral entry. It is used for access

to lode mining claims or to explore for blind or undiscovered veins, lodes, or ledges not currently claimed or known to exist on the surface. A tunnel site is a possessory right only and cannot be patented (30 U.S.C. 27; Rev. Stat. 2323; Act of May 10, 1872, ch. 152, sec. 4; 17 Stat. 92).

Tunnel sites are a possessory right to any blind veins, ledges, or lodes cut by the line of the tunnel, not previously known to exist, for a distance of 3,000 feet from the face of such tunnel. The term “face” is held to mean the first working face formed in the tunnel. It is the point at which the tunnel enters cover. The face is the point from which the 3,000 feet are to be measured. The line of the tunnel, within the meaning of 30 U.S.C. 27, is theoretically a cylinder that is 3,000 feet long and with a radius of 1,500 feet from the tunnel axis.

To take advantage of the benefits of this provision of law, the proprietors of a tunnel site shall give proper notice of their tunnel location by erecting a substantial post, board, or monument at the face or point of commencement. In order to provide notice to others whether or not they are within the boundary lines of the tunnel site, the proprietors must also establish the boundary lines of the tunnel sites. It is customary to monument and mark the line of the tunnel at such interval so that each succeeding monument or mark is visible from the last, beginning at the face or point of commencement of the tunnel and continuing a maximum of 3,000 feet to the end. From the end points, the four corners of the tunnel site should also be monumented, up to 1,500 feet each side.

**10-187.** Upon discovery, a mining claimant may use a tunnel site to acquire the mineral rights by locating a lode mining claim. The location date of the lode claim relates back to the location date of the tunnel site.

The right to a tunnel site location is lost by failure to develop the tunnel for a period in excess of 6 months or the failure to otherwise diligently prosecute (*United States v. Swanson*, 98 Interior Dec. 185 (1991)).

**10-188.** Where an exterior line of a claim intersects the boundary of a tunnel site, give the course and distances from the point of intersection to the corners of the site at each end of the segment of the boundary so intersected. If the corner tied to is not the nearest record corner or a record corner in a direction is not found, a statement will be made that a diligent search had been made but no evidence of the corner position was recovered.



## Extralateral Rights

**10-189.** The doctrine of extralateral rights allows a lode mining claimant to follow a vein beyond the vertical planes drawn through the side lines of the claim (30 U.S.C. 26). As such, the owner of a mining claim may develop “all veins, lodes and ledges throughout their entire depth, the top or apex of which lies” within the boundary lines extended downward vertically, even though the veins, lodes, or ledges extend outside the boundaries of the claim (*Del Monte Mining and Milling Co. v. Last Chance Mining and Milling Co.*, 171 U.S. 55 (1898)).

**10-190.** A mining claim location entitles the claimant to occupy the surface for mining purposes and to possess the underlying valuable mineral deposit, be it vein, lode, ledge, or disseminated in nature. The surface location is made to locate the rights beneath the surface. The end lines place the limits of the locator’s appropriation of any vein or veins along their course or strike, which illustrates the importance of the end lines parallelism concept when compared to the purposes of the side lines. The side lines measure the surface extent of the claim on each side of the middle of the vein at the surface (*Del Monte Mining and Milling Co. v. Last Chance Mining and Milling Co.*, 171 U.S. 55 (1898)).

In practice, during the location process, the best survey methods are frequently not used because of a desire to save both time and money. Indeed, it has been and was to be expected that such location surveys and markings would be made by the miners themselves, inexperienced in the matter of surveying. The result has been innumerable difficulties. For the mineral surveyor, the question is not what equity is, but what is the law, policy, and good survey judgment. The U.S. Supreme Court explained in *Iron Silver Mining Co. v. Elgin Mining & Smelting Co.*, 118 U.S. 196, 207 (1886), that:

If the first locator will not or cannot make the explorations necessary to ascertain the true course of the vein, and draws his end lines ignorantly, he must bear the consequences. He can only assert a lateral right to so much of the vein as lies between vertical planes drawn through those end lines.

**10-191.** Every vein having a top or apex lying inside the surface boundary lines of a lode mining claim extended downward belongs to the locator and may be pursued to any depth beyond the vertical side lines, even though in doing so, the locator may enter beneath the surface of another mining claim, or Federal or non-Federal lands

where the mineral estate was open to mineral location at the time of the location date. Conditions upon which extralateral rights may be acquired by locators of mining claims have been prescribed by Congress in 30 U.S.C. 26. Mining claimants shall satisfy those conditions when locating and developing their claims, or else be limited to minerals beneath the surface of their territories (*Del Monte Mining & Milling Co. v. Last Chance Mining & Milling Co.*, 171 U.S. 55 (1898)).

The existence of an apex within a given lode mining claim is not essential to the validity of the lode mining claim, but only to the mining claimant’s ability to assert an extralateral right derived from that mining claim.

Extralateral rights do not include the right of the lode claimant to trespass upon the surface of adjacent lands claimed or owned by others. However, location lines of a lode mining claim are used only to describe, define, and limit property rights in the claim. The location lines may be laid within, upon, or across the surface of patented or unpatented mining claims for the purpose of claiming the free and unappropriated ground within such lines and the veins apexing in such. The location lines serve in defining and securing extralateral underground rights upon all such veins, where such lines, (1) are established openly and peaceably and (2) do not embrace any larger area of surface, claimed and unclaimed, than the law permits (*The Hidee Gold Mining Co.*, 30 Pub. Lands Dec. 420 (1901)).

**10-192.** The primary consequence of a locator’s failure to locate his or her claim boundaries according to the actual course of the lode, whether by lack of care or lack of data, is that the claimant may be limited in his or her extralateral rights.

The actual course of a vein may materially deviate from the center line of a lode claim without adversely affecting the validity of the claim. The relationship between the actual course of the lode and the position of the mining claim’s lateral boundaries and center line does not affect the validity of the claim. Originally marked claim boundaries need not be adjusted to comport with the actual course of the vein, so long as the claim has been located in good faith for mining purposes. No portion of a lode mining claim shall be considered excessive where the statutory dimensions of 1,500 feet by 600 feet and, 300 feet on each side of the middle of the vein at the surface, are not exceeded.

The statute intends to prescribe the limit of the extent along the course of the lode that locators may claim,

and does not prescribe that they shall locate so that the greatest dimension of their claim shall coincide with the course of the lode. It is provided that the extreme extent along the lode shall not exceed 1,500 feet. It may be less and if the claimants, in making their locations, should mistake the direction of the lode upon which they locate, and thus make the extreme dimensions of the claim in a direction other than that of the lode, that fact does not invalidate their claims. It only operates to diminish the extent of the lode within the boundaries of the claim. The only result of so locating is that locators get less, in extent of the lode, than they would have otherwise. And that if the side lines, instead of the end lines, cross the course of the lode, in order to define the locators' rights to pursue the lode on its dip, the side lines will be treated as end lines (*Apex & Extralateral Rights Issues Raised by the Stillwater Mineral Patent*, M-36955, 93 Interior Dec. 369 (1986)).

**10-193.** Since the Act of May 10, 1872, parallelism in the end lines is essential to the existence of any extralateral rights. End lines mean such lines as are crossed by the lode on its course. Side lines may become end lines, sometimes called side-end lines.

The principle of the parallelism doctrine is that parallel means substantially parallel, not a mathematical precision, not exact (*Grant v. Pilgrim*, 95 F.2d. 562 (9<sup>th</sup> Cir. 1938)). A reasonable compliance with the law is all that is required. In a case where the end lines converge in the direction of the dip, the locator is entitled to the extralateral right between the converging planes. In a case where the end lines diverge in the direction of the dip, the locator is without extralateral rights. Where the location claim as originally marked upon the ground has nonparallel end lines, it may be rectified at any time, if such rectification does not interfere with intervening rights.

### Legal Subdivisions

**10-194.** Where placer claims or millsites are upon surveyed lands and conform to legal subdivisions, and properly executed and monumented, the official surveys are as permanent and fixed as is practicable. It is not required that the claim or site corners and boundaries be further marked on the ground. However, the object of the law is to inform other miners as to what portion of the ground is already occupied, which may not be satisfied in those surveyed areas where:

- (1) complicated conditions involve a double set of corners, both of which may be regarded as authentic;

- (2) there are no existing corners in one or more directions for an excessive distance;

- (3) existing marks are improperly related to an extraordinary degree; or

- (4) all evidences of the original survey that have been adopted by the claimant as a basis for his or her location have been lost before the subsequent claim is made.

**10-195.** The mere reference to the legal subdivision, in these latter areas, while providing a valid land description, in fact may not inform other miners as to what portion of the ground is within the claim, and the claim may, in fact, float or swing until the legal subdivision lines are definitely located on the ground by a survey or resurvey. Also, State law may require marking of the legal subdivision boundaries and monumentation of claim or site corners.

**10-196.** For location of placer claims or millsites that conform to the legal subdivisions, or for the segregation of mineral land from agricultural land by legal subdivisions, per 43 U.S.C. 766 (Rev. Stat. 2406; Act of July 9, 1870, ch. 235, secs. 12, 16; 16 Stat. 217), the subdividing may be done by county or other local surveyors at the expense of the claimants and under the direction and control of the Chief Cadastral Surveyor (30 U.S.C. 35; Rev. Stat. 2329; Act of July 9, 1870, ch. 235, sec. 12; 16 Stat. 217, and Rev. Stat. 2331; Act of May 10, 1872, ch. 152, sec. 10; 17 Stat. 94).

**10-197.** Where lots or irregular surveys of the PLSS are encountered, the rule of approximation may be applied to excess acreage. The rule is that the amount of excess may not exceed the amount of loss, if the smallest lot or legal subdivision of 10 acres for placers, or lot or legal subdivision of 5 acres for millsites, were eliminated. On the basis of 10-acre tracts for placers the allowable excess would be 4.99 acres, and on the basis of 5-acre tracts for millsites the allowable excess would be 2.49 acres (*Ventura Coast Oil Co.*, 42 Pub. Lands Dec. 453 (1913)).

**10-198.** When a mining claim or millsite cannot be described by legal subdivision, either because the land is unsurveyed or the claim or site does not conform to a legal subdivision, the BLM must reject a patent application when the applicant fails to survey the claim or site and submit the mineral survey along with his or her application (*Jack K. Carter*, 142 IBLA 1 (1997)).

When a mining claim or millsite cannot be described by legal subdivision, a nonrectangular description that fixes the position of the claim or site corners with respect to an official survey monument is required.

**10-199.** When a placer claim or millsite is on unsurveyed lands and cannot be described by legal subdivision, the claim or site should be described by the protraction diagram, if one is of record. If located by legal subdivision based upon a protraction diagram and the land is subsequently surveyed, an amended location certificate will be filed to properly fix the position of the claim or site on the ground.

Protraction diagrams are not official surveys. Therefore, the requirement that a placer mining claim or millsite patent application be accompanied by a mineral survey of the unsurveyed land is not waived when the unsurveyed land is covered by a protraction diagram (*Dennis J. Kitts*, 84 IBLA 338 (1985)).

**10-200.** Lots, whether those (1) on the north and west boundaries of a township, (2) created by segregation and patenting of lode mining claims, (3) created by meandered bodies of water, or (4) created by other special surveys, are a legal subdivision of official surveys. The subdivision of such lots into smaller legal subdivisions requires an official survey. A location certificate description “W $\frac{1}{2}$  of lot 1” does not conform and cannot be made to conform to the rectangular or legal subdivisions of the PLSS, and an official survey of the land located and claimed is necessary (*Holmes Placer*, 29 Pub. Lands Dec. 368 (1899)).

In many of the cases just described, a supplemental plat is prepared to show the modified legal subdivisions.

### Riparian Rights—Mining Claims and Millsites

**10-201.** The United States acquired the title to the lands beneath navigable waters equally with the title to upland but held the lands beneath navigable waters only in trust for the future States that might be created out of that territory (see chapters III and VIII for discussions on navigable waters). This principle is not applicable, however, to lands beneath navigable waters that Congress clearly intended to include within a reservation or affirmatively intended to defeat with respect to future State title to such land (*Ownership of Submerged Lands in Northern Alaska in Light of Utah Division of State Lands v. United States*, M-36911 (Supp. I), 100 Interior Dec. 103 (April 20, 1992)).

Therefore, title to the lands beneath navigable waters passed to the State upon statehood, including the mineral estate, subject to certain recognized exceptions. The lands beneath navigable waters are subject to the laws of the State in which they are situated and are not locatable under the United States mining laws (*Charles B. Reynolds, Jr., et al.*, 56 Interior Dec. 60 (1937)). However, in some States, title to lands beneath navigable waters has been relinquished to riparian owners to varying degrees, some completely. The United States and a State may sometimes have a dispute over whether certain waters are navigable waters. In those circumstances, a determination of whether those waters qualify as navigable waters may be necessary before a State can assert ownership over the lands beneath those waters.

By the acts of 1849, 1850, and 1860, some States were granted swamp and overflowed lands. The United States did not retain the mineral estate to these lands.

**10-202.** When mining claims or millsites not described by legal subdivisions contain language in the location notice or claim map that clearly indicates that a line of the claim or site adjoins or overlaps lands beneath navigable waters, the ordinary high water mark for inland waters or the line of mean high tide for tidal waters becomes the boundary of the side line of the claim and of the millsite. The end line of the claim, for extralateral purposes, can be located out in the water body.

In such instances, it is proper to run a meander line as a boundary, and where this is done the field notes of the mineral survey or mineral segregation survey will state that it is a meander line of the ordinary high water mark or the line of mean high tide, and that the corners of such line are meander corners or angle points on the meander line. The situation is well stated in *Alaska United Gold Mining Co. v. Cincinnati-Alaska Mining Co.*, 45 Pub. Lands Dec. 330, 343 (1916):

The Department is clearly of the opinion that the rule as to meander lines is, both in principle and reason, as applicable to mining claims as to other classes of claims, and that where in the course of an official patent survey of a mining claim abutting upon a navigable body of water a meander line, which follows as nearly as practicable the shore line of such water, has been run, such shore line and not the meander line must be taken as a boundary of the claim when patented according to the plat and field notes of the survey of such claim.

If one entire end of a claim is delineated by a meander line, the end line is protracted parallel to the inland end line at the farthest waterward point of the meander line for the purpose of determining extralateral rights.

**10-203.** In States where title to lands beneath navigable waters has been relinquished to riparian owners and the mining claim or millsite contains language in the location notice or claim map that clearly indicates that a line of the claim or site adjoins or overlaps lands beneath navigable waters, the surveyor will consult with the BLM mineral adjudicator prior to the completion of the mineral survey.

**10-204.** Where one of the boundaries of a claim or site, not described by legal subdivisions, is a navigable body of water, all insubstantial land formed by accretion due to natural or artificial causes since the date of patent survey passes to the patentee, as do accretions formed after patent. The Department having no jurisdiction, such lands become the property of the riparian proprietor.

**10-205.** Federal lands open to the operation of the Mining Law of 1872 and lying beneath nonnavigable waters are subject to location under the United States mining laws. Meandered lands beneath nonnavigable waters are subject to location when the abutting upland is unappropriated, or patented with a mineral reservation.

When a mining claim or millsite, not described by legal subdivisions, adjoins, or is within meandered lands beneath nonnavigable waters, by current practice the field notes of the mineral survey or mineral segregation survey will state whether the boundary is, or is not, a meander line of the ordinary high water mark, and whether the corners of such line are meander corners and angle points on the meander line governed by the doctrine of accretion. If not clearly stated in the location notice or on a claim map, the presumption is that the boundary of the claim or site is a fixed boundary with no riparian rights.

**10-206.** For mining claims or millsites described by legal subdivisions, the doctrine of accretion governs the movement of boundaries of meandered lands adjoining nonnavigable waters. Movement of the boundaries of legal subdivisions resulting from accretion, erosion, reliction, or avulsion, after survey and prior to location of the claim or site, and thereafter, all govern the claim or site boundary of the riparian proprietor. This is subject to the standard exceptions where there is fraud, gross error shown in the survey, or an intention to limit

a grant, conveyance, claim, or site to the actual meander lines as disclosed in the facts or circumstances.

**10-207.** For mining claims or millsites described by legal subdivisions of meandered lands adjoining nonnavigable waters, the medial line of the body of water, that is, a line located midway between the opposite ordinary high water marks, is the boundary of the claim or site. In such instances, it is proper to run such a boundary as a claim or site boundary line, and the field notes of the mineral survey or mineral segregation survey will state that it is a survey of the medial line of the body of water, that it is ambulatory, and that the corners of such line are claim or site corners (see sections 8-21 through 8-31).

The principles described in sections 8-187 through 8-189 also apply to mineral lands surveys.

### Resurveys—Mineral Lands

#### *The Nature of Dependent Resurveys of Mineral Surveys*

**10-208.** Dependent resurveys of mineral lands involve many of the same considerations and principles as dependent resurveys of rectangular public lands. In addition, the surveyor must know the processes governing mineral lands location, notice, survey, entry, and patent that vary from other public land laws, and how each could affect the position of the rights on and beneath the surface of the earth. There are three overlapping objects of such dependent resurveys: First is the adequate protection and marking of existing rights acquired under the original survey in the matter of position beneath the surface of the earth. Second is the adequate protection and marking of existing rights acquired under the original survey in the matter of position on the surface of the earth. Third is the proper marking of the boundaries of the remaining Federal interest lands.

**10-209.** A principle governing the physical location of boundary lines extending downward beneath the surface is that the end lines of lode claims are to be substantially parallel based upon the degree of precision accepted at the time of the original survey.

**10-210.** As to position on the surface of the earth, contiguous mining claims, not described by legal subdivisions, are either simultaneous or sequential grants with simultaneous or sequential surveys. This characteristic differs from rectangular grants and surveys, which are predominately simultaneous in character. This



distinction is fundamental to the work of the dependent resurveyor of mineral lands and mining claims.

**10-211.** Retracement principles of public land surveys are also applicable to mineral land surveys. The recognition of questions caused by significant discrepancies between survey or patent records, from the actual, found, on-the-ground-conditions, led to Congressional action. For mineral lands, acknowledgement and remedy appears at 30 U.S.C. 34 (Act of April 28, 1904; 33 Stat. 545), which states that monuments are to be the highest authority to which inconsistent descriptions shall give way, thereby making even more explicit this existing statutory and common law retracement principle. The statute reads as follows:

The description of vein or lode claims upon surveyed lands shall designate the location of the claims with reference to the lines of the public survey, but need not conform therewith; but where patents have been or shall be issued for claims upon unsurveyed lands, the Director of the Bureau of Land Management in extending the public survey, shall adjust the same to the boundaries of said patented claims so as in no case to interfere with or change the true location of such claims as they are officially established upon the ground. Where patents have issued for mineral lands, those lands only shall be segregated and shall be deemed to be patented which are bounded by the lines actually marked, defined, and established upon the ground by the monuments of the official survey upon which the patent grant is based, and the Director of the Bureau of Land Management in executing subsequent patent surveys, whether upon surveyed or unsurveyed lands, shall be governed accordingly. The said monuments shall at all times constitute the highest authority as to what land is patented, and in case of any conflict between the said monuments of such patented claims and the descriptions of said claims in the patents issued therefor the monuments on the ground shall govern, and erroneous or inconsistent descriptions or calls in the patent descriptions shall give way thereto.

The practical effect of this statute is that when the locus of a mining claim becomes uncertain, the surveyor shall locate the land embraced in the survey and bounded by the lines actually marked, defined, and established on the ground by monuments substantially within the requirements under the law and official regulations and

corresponding to the description thereof in the patent (*Sinnott v. Jewett*, 33 Pub. Lands Dec. 91 (1904)).

**10-212.** The standards of evidence governing existent, obliterated, and lost corners outlined in chapters V, VI, and VII are applicable to resurveys of mineral survey.

### *Lost Corners*

**10-213.** There is no hard and fast rule for reestablishing lost corners of lode mining claims. The method should be selected that will give the best results, bearing in mind that end lines of lode claims should remain substantially parallel, if parallel by record. When the original surveys were made faithfully, the application of the principles of parallelism, record distances, record angular relationships, and record relationships between the claim and the workings on it, in combination with the presumption that the original intent was to be conformable with the statutes governing dimensions and area, should substantially meet the objectives stated above.

In restoring lost corners of irregular claims, such as nonrectangular placers or millsites, the secondary methods of broken boundary adjustments (sections 7-53 and 7-54) should be considered. These may also be applied to lode claims if application of the methods described in the previous section does not give adequate results.

In restoring lost corners of a block of claims, originally surveyed at the same time, the primary methods of proportionate measurement should be considered. The field notes and order should be consulted to determine if the basis for record directions deviates from the general plan (section 10-121).

As with all lost or obliterated corners, the position of a corner of a mineral survey must be determined from the best available evidence and in such a configuration that will place the lines as nearly as possible in their original positions.

**10-214.** Caution should be exercised in the use of any ties to or from adjoining surveys when the descriptions for the conflicting claim corners, PLSS corners, or mineral monuments are not mentioned in the field notes memorandum and may in fact have only been calculated and not surveyed on the ground. Such calculated ties, as a rule, should not be used.

### *Physical Location and Title Conflict*

**10-215.** In cases where physical locations or titles of claims or sites are in conflict, the surveyor should be



familiar with critical actions in order to gather facts relevant for the deciding officer(s)'s determination of the physical limits of rights.

As a general rule, "first in time, first in right" will determine the priority of conflicting mining claims or sites. Determining the extent of rights to a mining claim or site typically depends on evidence gathered from prior sequential grants and surveys.

**10-216.** The date of a specific act, whether by the claimant, Government, or a third party, will often determine, or provide evidence of, the priority of physical location and ownership rights on or beneath the surface of the earth. Generally, (1) the date of the official filing of the mineral survey is the controlling event for survey and survey corners and boundary purposes, i.e., physical location or position, and (2) the date of the mineral patent is the controlling event for title purposes.

To determine if there is a physical location or title conflict, the following actions and dates must be known:

(1) Location Date – The location date is the date the claimant has attested that the corners and exterior lines of the claim were marked on the ground and the location notice was posted on the ground. The amended location date is the date the claimant has attested that the amended location notice was posted on the ground. To maintain the priority of either such date, the claimant shall subsequently comply with all appropriate Federal and State laws and regulations. The claimant shall record (file) the location certificate and amended location certificate (if the location is amended) with the BLM and the county within the allotted time. The location notice (and amended location notice, when necessary) shall include the name of the location (claim), type of location (claim), the location date, the name and address of the locator (claimant), and location (claim) description including legal subdivision within the quarter section. The location date and amended location date may determine:

- (a) the date of the possessory right,
- (b) the spatial relationship of the boundaries of the location (claim) and other lands held by the United States, and

- (c) the relative junior-senior title rights as to third party claimants.

(2) Mineral Survey Filing Date – The mineral survey filing date is the date the mineral survey plat and any adjustments, amended surveys, or supplemental plats thereto, approved upon signature by the BLM State Office Chief Cadastral Surveyor are officially filed. A bona fide right as to physical location (position) relates back to the filing date of the mineral survey.

(3) Final Certificate Date – By Departmental procedure applicable from 1866 to 1958, the Department issued a single "mineral entry final certificate" to patent applications before they received the patent to show that the applicant had complied with all of the "paperwork" requirements for obtaining a patent under the Mining Law. A patent application is subject to protest and appeal until the date of the patent. When the patent was ultimately issued, the date of the property interest related back to the location date. The position or physical location associated with this interest is fixed as of the filing date of the mineral survey of the mining claim. This is done in an effort to ensure any bona fide rights or claims of any claimant, entryman, or owner of lands are protected pursuant to 43 U.S.C. 772. The final certification date is also known as the mineral entry date.

If the Department verified that the applicant had a valid discovery of a valuable mineral deposit (or, in the case of a millsite, verified that the land was nonmineral in character and was being used and occupied in support of a previously or concurrently patented mining claim), and otherwise satisfied the requirements for patenting under the Mining Law, the Department issued a patent, which contained any applicable reservations, exceptions, and restrictions.

(4) First and Second Half Final Certificates – Under Departmental procedures in effect from 1958 until Congress imposed a moratorium in 1994 prohibiting the Department from processing new and nongrandfathered patent applications, the final certificate was issued in two parts. When the first half was signed, the signature date was called the date of mineral entry. From a resource management standpoint,

this meant that surveyors were to protect any physical position associated with this “mineral entry,” per 43 U.S.C. 772, in the event the claim ever went to patent.

The second half of the mineral entry final certificate was completed after the mineral examination, and listed only those claims or sites for which the Department had verified discovery of a mining claim or proper use and occupancy of a millsite. The second half of the mineral entry final certificate is generally signed at the same time as the patent, and it is the patent that transfers legal title to the claim to the applicant. The date of the property interest relates back to the signature date of the first half certificate and the physical position associated with the mining claims and millsites that are included in the patent is fixed as of the filing date of the mineral survey of the mining claim and millsites. This is done in an effort to ensure any bona fide rights or claims of any claimant, entryman, or owner of lands are protected pursuant to 43 U.S.C. 772.

(5) Post-Moratorium Patenting Procedures – In 1997, the Solicitor issued a legal opinion recommending that BLM discontinue using the two-part final certificate system and return to the previous procedure of issuing only one final certificate (see *Entitlement to a Mineral Patent Under the Mining Law of 1872*, M-36990 (November 12, 1997)). However, although grandfathered patent applications are still being processed, because of the Congressional moratorium on new patent processing, BLM has not revised its policies as to issuance of final certificates.

(6) Patent Date – The patent date is the date of the signature on the patent, i.e., the date when full and final legal title from the Federal Government is transferred to the applicant. The patentee’s property right as to title relates back to the location date, but the physical position associated with that right relates back to the filing date of the mineral survey. This is done in an effort to ensure any bona fide rights or claims of any claimant, entryman, or owner of lands are protected pursuant to 43 U.S.C. 772. The patent issuance is final, except in cases of fraud or mistake, which are subject to a statute of limitations.

These various dates and positions may be affected by a contest, quiet title action, adverse proceeding, mineral survey, amended mineral survey, supplemental plat, confirmation of a discovery of a valuable mineral deposit, protest, appeal, fraud, or mistake. The dates may also be affected by a new location, relocation, new mineral survey, or other causes.

**10-217.** The mining laws of the United States involve two classes of rights or titles: (1) mining claims, which, if valid, include a right of possession, and (2) patents, which convey title from the Federal Government to the extent permitted by the relevant authorizing legislation.

**10-218.** A patent from the United States vests in the grantee of the Government an indefeasible title to the mineral deposits (and, in most cases, the surface estate as well), whereas a mining claim may be defeated at any time by the failure of the claimant to, for example, properly maintain the mining claim or site, or perform the labor or make the annual improvements required by statute (see *Benson Mining & Smelting Co. v. Alta Mining & Smelting Co.*, 145 U.S. 428 (1892); *Am. Hill Quartz Mine*, Copp’s *U.S. Mineral Lands*, p. 254), or to prove discovery of a valuable, i.e., profitable, mineral deposit.

**10-219.** Legal title transfers from the Government immediately upon issuance of the patent.

**10-220.** The property right in a valid mining claim or site may continue for an indefinite term of years and can only be terminated by a failure of the claimant to comply with the terms of the statute or a successful assertion of claim to the land by another. There is nothing in the law, however, that requires the holder of a valid mining claim to patent or purchase the land from the Government. As long as the claimant complies with the applicable laws, his or her right to use and benefit from the land, for all practical purposes, is as good as though the land were secured by patent.

**10-221.** The previous discussion addresses rights to both the surface estate and the subsurface estate, including the extralateral estate. It can be inferred that similar rationale applies to the bona fide rights, for all classes and rights, as to position on the earth’s surface and beneath the earth’s surface. As to position, once the statutory requirements have been met, the claimants “shall have the exclusive right of possession and enjoyment of all the surface included *within the lines* of their location claims although the United States retains title to the land” (*California Coastal Commission v. Granite*

*Rock Co.*, 480 U.S. 572, 575 (1987), emphasis added). The surveyor must be able to recognize when bona fide rights as to position of the surface estate are not identical with the bona fide rights as to position of the subsurface estate.

**10-222.** Therefore, in very general terms and by today's rules and regulations, the point at which the position on and beneath the earth's surface of a mining claim becomes fixed by survey, for each class of title, may be described as follows:

(1) Possessory Right – When a mining claimant locates a mining claim but the claim is not yet perfected, the physical position of the claim is, to a degree, floating on the location date. This is so because: (1) the position of the mineral patent survey corners may be positioned inward of the location survey corners in order to meet statutory size limitation requirements; (2) one or more 10-acre aliquot parts of a placer claim may be determined to be nonmineral, or (3) a 2½-acre aliquot part of a millsite may be determined mineral in character or not.

(2) Perfected Unpatented Mining Claim – When a mining claimant locates a mining claim and then perfects the claim, the position or physical location becomes fixed on the filing date of the mineral survey, amended mineral survey, or supplemental plat, subject to adverse proceedings and mineral examination validation. One survey plat may cover a portion of the patent description, and another plat with a different filing date may cover the remainder of the patent description.

(3) Patented Mining Claim – The position or physical location of a patented mining claim becomes fixed on the filing date of the mineral survey, and/or on the filing date of any amended mineral survey or supplemental plat. One survey plat may cover a portion of a patent description, and another plat with a different filing date may cover the remainder of the patent description. Upon issuance of the patent, the physical position of the claim boundaries becomes the full legal boundaries between the land held by the new legal owner of the patented land and the United States. The physical position of such boundaries is subject to preexisting boundary conflicts with previously alienated lands on one or more sides.

**10-223.** Before the date that title vests, as evidenced by the patent, the claimant's right as to position on the surface of the earth between the applicant and the United States is still to be determined. This is apparent, for example, if during the patent application survey, the mineral surveyor determines the location to be in excess of the statutory maximum area. This is also apparent where a portion of a placer claim is determined by adjudication to be nonmineral in character. In cases like these, the claim or site boundaries are adjusted without impairing bona fide rights as to position on the surface of the earth.

#### *“Gaps and Overlaps” Not of Record*

**10-224.** Patented and unpatented claims and sites were often surveyed as contiguous to each other by sequential surveys. When the record is clear that monuments were set to mark corners common to two claims, the presumption is that the claim line as marked is common to the two claims. Experienced surveyors know in the case of offset claim corners along a boundary between contiguous claims that, after monumentation, technical gaps or overlaps will exist. These are not legal or title conflicts. It is known that every measurement contains some error, and it is impossible to put a monument exactly on the straight line between two other monuments; slight variations in direction or distance are unavoidable and acceptable.

During the retracement, the extent of the falling of the intermediate monument from the straight line between the two other monuments is measured. An analysis of conditions will be conducted and a determination made as to whether the line is common to the claims or the error is so gross as to impair a legal right as to position so that the claims were never contiguous.

**10-225.** When the relationship between the monuments is substantially as approved, and there is no evidence of fraud, mistake, or gross error, the line running through the intermediate monument, as measured, will be returned as common to the claims.

When determining whether the conditions found during the retracement are substantially as approved, the surveyor shall be guided by law, rules, official policy, effect on extralateral rights, and survey principles thereof.

**10-226.** When duly authorized, the surveyor is acting under the authority of the Secretary of the Interior. Congress has empowered the Secretary, or such officer as he or she may designate, to perform all executive

duties appertaining to the survey of Federal lands, including mineral, lands.

It is also for the Secretary, acting through the Chief Cadastral Surveyor, to determine the boundary location of lands within Federal province. The surveyor is required to give effect to the conditions existing when the monument was established. The general surveying principle is applied: if the monumented position was valid at the time set, the surveyor is not at liberty to disapprove it by reason of a subsequent change in conditions. Furthermore, the extent of recognition given by neighboring claimants to a monument used for the control of the position of claims and patents very often carries with it the necessity for a consideration of its influence in the matter of the acceptability of such positions under the good faith location rule (section 6-35).

The intermediate monument in its original position, but not at its record position, was approved even though based on false assumptions. Unless set aside by direct proceedings, such a decision of approval, even with the technical error, will bind the Government except when fraud, mistake, or gross error can be proven. Questions respecting position are to be determined by the conditions existing at the time when all requirements necessary to approve the survey had been complied with, and no subsequent change in such conditions can affect this physical location.

Reviewing courts will hold unlawful and set aside agency action, findings, and conclusions found to be arbitrary, capricious, an abuse of discretion, or otherwise not in accordance with law or in excess of statutory authority. However, a reviewing court may not substitute its judgment for that of the agency. An agency's interpretation of its own regulations and of the statutes it administers is entitled to deference.

**10-227.** Once accepted, an official survey and the monumented positions thereof can affect title to private land, at least to the extent of giving rise to an apparent boundary conflict and establishing a cloud on title. The United States retains the power to make corrective adjustments for prior erroneous survey monument positions, and the BLM has the burden of proving that a monument position of an official survey is erroneous. Changing the position of duly authorized lines or monuments years after approval may result in calling into question title to narrow strips of land (*de minimis*). The courts have emphasized they are very reluctant to overturn long-established and accepted boundaries, as is Congress, as demonstrated by the limitation

of Government's authority to conduct resurveys once the physical position of a mining claim is fixed on the basis of an official survey (see 43 U.S.C. 772) (*State of Oregon v. Bureau of Land Management*, 876 F.2d 1419 (1989)).

Where questions arise which affect title to land it is of great importance to the public that when they are once decided they should no longer be considered doubtful. Such decisions become rules of property, and many titles may be injuriously affected by their change. Legislatures may alter or change their laws, without injury, as they affect the future only, but where courts vacillate and overrule their own decisions on the construction of statutes affecting title to real property, their decisions are retrospective and may affect titles purchased on the faith of their stability (*Minnesota Mining Co. v. National Mining Co.*, 70 U.S. 332 (1865)).

**10-228.** An official resurvey cannot impair any bona fide rights or claims of any claimant, entryman, or owner of lands affected by such resurvey (43 U.S.C. 772). In cases where gaps or overlaps are not in the official record, the subsequent identification of long narrow strips and isolated small plots of land by rigorous application of modern technology during a mineral dependent resurvey or retracement will ordinarily not be accepted as defining survey and title lines. The issue of good faith based upon stability and substantially as approved has been raised by the courts and the land department. The single line running through an intermediate monument will ordinarily be supported by returning, on the official resurvey plat and field notes, a single monument and a single line. This reflects the actual conditions and will be adopted unless there is an overwhelmingly compelling public policy or due process reason not to do so.

**10-229.** For claims described and surveyed as contiguous, the intent of the Federal Government is neither to retain unmanageable slivers of land nor to convey land described in a senior grant or conveyance.

By policy no longer in effect, monuments were set on existing lines without benefit of retracement. The reported intersection point was tied to only one corner of the existing line. In these cases where the monument is found to be not at the record position, the monument should determine the direction of the line but not its legal terminus. The true position is at the point determined by extending or terminating the line to intersect



with the fixed line (see section 7-45 for survey and monumentation procedures).

Where field notes report clearly that the monuments were set at intersection points and an obviously careful retracement of a line had been made, the monuments become the best available evidence of the position of both lines. In such a case, all monuments will exercise control for both measurement and alinement of the lines.

On rare occasions the second surveyor patently established a completely separate line, creating a hiatus or overlap. In this case, each set of corners would then control only its respective line. Where complications develop, the surveyor will report to the supervising office the identity and correlation of corners and other evidence.

## Special Cases

**10-230.** Experience, thoroughness, and good judgment are indispensable for the successful retracement and recovery of any survey when it reaches a stage of extensive obliteration, there is manifest distortion, or there are years of unofficial boundary determinations resulting in confused and conflicting lines and corners. It is an axiom among experienced cadastral and mineral surveyors that the true location of the original lines and corners can be restored, if the original survey was made faithfully, and was supported by a reasonably good field-note record. That is the condition for which the basic principles have been outlined, and for which the

rules have been laid down. The rules cannot be elaborated to reconstruct a grossly erroneous survey or a survey having fictitious field notes. The methods applicable to dependent resurveys of mineral surveys and mineral segregation surveys are designed to rectify the conditions that are at variance with the representations of the official field notes and plat.

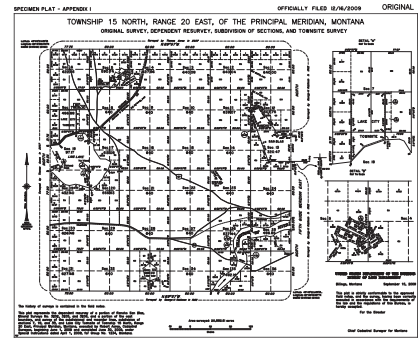
**10-231.** The records of official resurveys cover many special cases. The records in the BLM Cadastral Survey offices include special cases from all mineral-land States. These plats, field notes, reports of office and field examinations and investigations, office opinions, supplements to this Manual (section 1-12), Departmental decisions, opinions from the Interior Solicitor or Attorney General of the United States, court opinions and decrees, and administrative land law decisions are drawn upon when needed to assist the surveyor in the study of situations that are new to his or her own experience. In administrative appeals of official surveys and trials of boundary suits, the board or court will generally consider many additional questions besides the purely technical. The surveyor will likely find that the proper exercise of discretion lies in the realm where technical and nontechnical matters overlap. When the surveyor encounters unusual situations, or finds it difficult to apply the normal rules for good faith location and substantially as approved or for the restoration of lost corners, the surveyor will report the facts to the proper administrative office. If it is determined that additional retracements are necessary, these may be provided for by supplemental special instructions or order.





# Appendix I

# Specimen Field Notes



## ORIGINAL SURVEY

---

UNITED STATES  
DEPARTMENT OF THE INTERIOR  
BUREAU OF LAND MANAGEMENT

### FIELD NOTES

OF THE

DEPENDENT RESURVEY

OF A PORTION OF RANCHO SAN BLAS,  
MINERAL SURVEYS NO. 3202, 3205, AND 3206,  
AND A PORTION OF THE EAST BOUNDARY,

AND

SURVEY OF THE

SUBDIVISIONAL AND MEANDER LINES,  
SUBDIVISION OF SECTIONS 7, 18, AND 33

AND LAKE CITY TOWNSITE

OF

TOWNSHIP 15 NORTH, RANGE 20 EAST,

OF THE PRINCIPAL MERIDIAN

IN THE STATE OF MONTANA

---

### EXECUTED BY

Robert Acres, Cadastral Surveyor

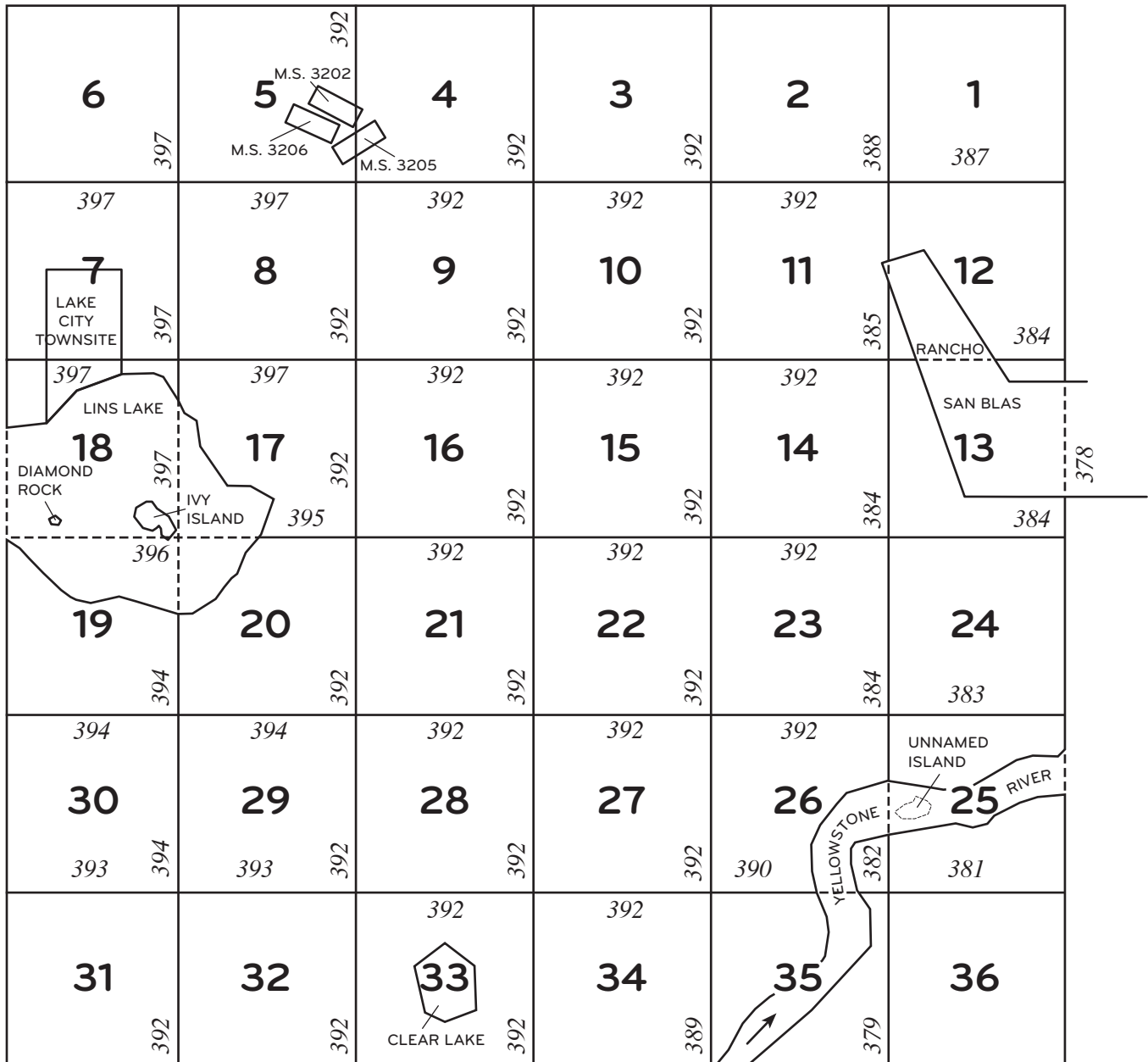
Under special instructions dated April 1, 2009,  
which provided for the surveys included under Group Number 1234,  
approved April 10, 2009, and assignment instructions dated May 20, 2009.

Survey commenced: June 1, 2009  
Survey completed: June 30, 2009



### INDEX DIAGRAM

TOWNSHIP 15 NORTH, RANGE 20 EAST, PRINCIPAL MERIDIAN, MONTANA



Resurvey of a portion of Rancho San Blas .....page 378  
 Resurvey of Mineral Surveys No. 3202, 3205, and 3206 ....page 378  
 Meanders of Lins Lake .....page 398  
 Meanders of Diamond Rock .....page 399  
 Meanders of Ivy Island .....page 400  
 Meanders of Yellowstone River.....page 400  
 Meanders of Clear Lake.....page 401  
 Subdivision of Section 7 .....page 401  
 Subdivision of Section 18 .....page 404  
 Subdivision of Section 33 .....page 404  
 Survey of Lake City Townsite .....page 405



## Township 15 North, Range 20 East, Principal Meridian, Montana

CHAINS	<p>The following field notes are those of the dependent resurvey of a portion of Rancho San Blas, Mineral Surveys No. 3202, 3205, and 3206, and a portion of the east boundary, and the survey of the subdivisional and meander lines, subdivision of sections 7, 18 and 33, and Lake City Townsite of Township 15 North, Range 20 East, Principal Meridian, Montana.</p> <p>The history of surveys pertaining to this survey is as follows:</p> <p>Rancho San Blas was surveyed by S. W. Groom, U.S. Deputy Surveyor, in 1857, as shown on the official plat of survey approved February 9, 1862.</p> <p>Mineral Survey No. 3202 Gold Dust lode, Mineral Survey No. 3205 Nugget lode, and Mineral Survey No. 3206 Primrose lode, were surveyed by Roy P. Brandy, Mineral Surveyor, in 1889, as shown on the official plat of surveys accepted July 4, 1889.</p> <p>The south and east boundaries were surveyed by George H. Robinson, U.S. Deputy Surveyor, in 1902, as shown in the official field notes approved January 20, 1903.</p> <p>The north and west boundaries were surveyed by Thomas Acres, U.S. Deputy Surveyor, in 1907, as shown on the official plat of survey accepted February 1, 1908.</p> <p>The preliminary exterior of the Lake City townsite was surveyed by Waverly J. Kayner, Yellowstone County Surveyor, in 1947, as shown in Townsite Entry Helena 039976.</p> <p>The resurvey of a portion of the Rancho San Blas private land grant, of Mineral Surveys Nos. 3202, 3205, and 3206, and a portion of the east boundary were made prior to the subdivision of the township.</p> <p>The meandering of all islands was not authorized in the special instructions. Title determination and survey of the remaining islands will be accomplished under future special instructions. Lins Lake, Yellowstone River, and Clear Lake were segregated for lotting purposes only.</p> <p>An examination on the ground and consultation with the surveyor who was employed by the applicants for the subdivision of the Lake City townsite reveals that a preliminary survey was initiated at the <math>\frac{1}{4}</math> section corner of sections 7 and 12, on the west boundary of the township. A line was then run easterly with the intention of conformance of the north boundary of the townsite to the east and west center line of section 7, when officially established. A calculated position for the center west <math>\frac{1}{16}</math> section corner on that line was adopted as the preliminary northwest corner of the townsite, and the preliminary northeast corner was placed at a point where a line running south would include all contemplated improvements. The preliminary east and west boundaries were run south to Lins Lake. This preliminary plan was adhered to.</p> <p>The location of the rights-of-way of the Montana and Manitoba Railroad, U.S. Highway No. 87, State Highway No. 25, and Big Sky Telephone lines with reference to the subdivisional survey is ascertained by notation of the intersections on the section boundaries, and by aid of the maps filed with the application for rights-of-way across</p>
--------	---



## Township 15 North, Range 20 East, Principal Meridian, Montana

## CHAINS

public land. Land occupied by the railroad, highways, and telephone lines was not segregated.

The survey was executed in accordance with specifications set forth in the Manual of Surveying Instructions (2009) and the Special Instructions for Group No. 1234, Montana, dated April 1, 2009.

The direction and length of lines were determined by Global Positioning System (GPS) Real-Time Kinematic (RTK) observations using Brand Name Model No. 357XZ, and augmented by means of lines projected by fore and backsights and distances measured with a Brand Name TXY778 Total Station. The instruments were calibrated by comparison with the National Geodetic Survey Calibration Base Line located at the Worden State Park, and were found to be within accepted tolerances. The direction of each line is with reference to the true meridian. All bearings are mean bearings. The distances are reported as horizontal measurement at a mean ground elevation of 3,500 feet above sea level, in U.S. Survey Foot. All lines not forming a closure were measured twice to preclude blunder.

Preliminary to the survey search was made for all corners, lines, other calls of the official record, and where available, collateral evidence of local surveys and corners. Identified corners were remonumented in their original positions. The lines of this survey were posted and blazed where indicated by the phrase "posting and blazing true line."

A magnetic memorial was deposited beneath the base of each monument where indicated. This memorial consists of a magnet, 1 in. long,  $\frac{7}{8}$  in. diam., housed in a cellulose acetate tube,  $2\frac{5}{8}$  ins. long, 1 in. diam., with 1 in. sq. polyethylene end caps, one black and one white.

The geographic positions, in NAD 83 (CORS96), epoch 2002.00, for the corners below were determined by GPS observations to a *Network Accuracy* of less than 0.10 meters, 95 percent confidence circle, as defined in Standards and Guidelines for Cadastral Surveys Using Global Positioning System Methods, May 9, 2001, Version 1.0.

The southeast corner of the township is as follows:

Latitude 45°45'02.458" N.      Longitude 107°54'13.367" W.

The northwest corner of the township is as follows:

Latitude 45°50'15.065" N.      Longitude 108°01'38.273" W.

The mean magnetic declination is 18°10' E.

---

EDITOR NOTE.— The field notes of the resurvey of a portion of Rancho San Blas, Mineral Surveys No. 3202, 3205, and 3206, and a portion of the east boundary are omitted. The full complement of corner accessories at some corners is omitted.

---





Subdivision of T. 15 N., R. 20 E., Principal Meridian, Montana

CHAINS	<p>From the cor. of secs. 1, 2, 35, and 36, on the S. bdy. of the Tp., monumented with a sandstone, 8 x 6 x 5 ins. above ground, firmly set, mkd. with 1 notch on E. and 5 notches on W. edge, from which the original bearing trees</p> <p style="padding-left: 40px;">A sawed cottonwood stump, 14 ins. diam., bears N. 10° E., 25 lks. dist., with the marks T15N visible on opened blaze.</p> <p style="padding-left: 40px;">A cottonwood, 10 ins. diam., bears S. 55° E., 10 lks. dist., with healed blaze.</p> <p style="padding-left: 40px;">A green ash, 13 ins. diam., bears S. 25° W., 33 lks. dist., with fragmentary scribe marks visible on open and partly rotted blaze.</p> <p style="padding-left: 40px;">A cottonwood, 12 ins. diam., bears N. 25° W., 50 lks. dist., with healed blaze.</p> <p>At the corner point</p> <p>Set a stainless steel post, 30 ins. long, 2½ ins. diam., 23 ins. in the ground, and in a mound of stone, 2 ft. diam., to top, with brass cap mkd.</p> <div style="text-align: center; margin: 10px 0;"> <table style="border-collapse: collapse; margin: auto;"> <tr> <td style="border-right: 1px solid black; padding: 0 5px;">T 15 N</td> <td style="padding: 0 5px;">R 20 E</td> </tr> <tr> <td style="border-right: 1px solid black; padding: 0 5px;">S 35</td> <td style="padding: 0 5px;">S 36</td> </tr> <tr> <td style="border-right: 1px solid black; padding: 0 5px;">S 2</td> <td style="padding: 0 5px;">S 1</td> </tr> <tr> <td colspan="2" style="text-align: center; padding: 0 5px;">T 14 N</td> </tr> <tr> <td colspan="2" style="text-align: center; padding: 0 5px;">2009</td> </tr> </table> </div> <p>from which</p> <p style="padding-left: 40px;">A lodgepole pine, 12 ins. diam., bears N. 4° E., 41 lks. dist., mkd. T15N R20E S36 BT.</p> <p>Raise a mound of stone, 3 ft. base, 2 ft. high, 5 lks. dist., W. of cor.</p> <p>Buried the sandstone alongside and deposit a magnet beneath the stainless steel post.</p> <p>N. 0°01' W., bet. secs. 35 and 36.</p> <p>Over level bottom land.</p> <p>20.00 Enter scattering timber; edge bears N and S.</p> <p>29.30 SE cor. of field; leave scattering timber.</p> <p>31.50 NE cor. of cabin, 15 x 12 ft., bears West, 6.15 chs. dist.; long side bears N. 10° E. and S. 10° W.</p> <p>39.50 Center line strip of State Highway No. 25, asphalt surface, 35 lks. wide, bears North along sec. line, and East.</p>	T 15 N	R 20 E	S 35	S 36	S 2	S 1	T 14 N		2009	
T 15 N	R 20 E										
S 35	S 36										
S 2	S 1										
T 14 N											
2009											



## Subdivision of T. 15 N., R. 20 E., Principal Meridian, Montana

CHAINS 40.00	<p>Point for the ¼ sec. cor. of secs. 35 and 36.</p> <p>Set a stainless steel post, 12 ins. long, 2½ ins. diam, with top 2 ft. below surface of highway, with brass cap mkd.</p> <div style="text-align: center;"> <table style="margin: auto;"> <tr><td>T 15 N</td><td>R 20 E</td></tr> <tr><td>1/4</td><td></td></tr> <tr><td>S 35</td><td>S 36</td></tr> <tr><td colspan="2"> </td></tr> <tr><td colspan="2">2009</td></tr> </table> </div> <p>from which</p> <p style="padding-left: 40px;">An iron post, 28 ins. long, 2½ ins. diam., set 24 ins. in the ground and over a magnet, for a reference monument, bears East, 46 lks. dist., with brass cap mkd. T15N R20E 1/4 S36 RM 2009 and an arrow pointing to the cor.</p> <p style="padding-left: 40px;">An iron post, 28 ins. long, 2½ ins. diam., set 24 ins. in the ground and over a magnet, for a reference monument, bears West, 46 lks. dist., with brass cap mkd. T15N R20E 1/4 S35 RM 2009 and an arrow pointing to the cor.</p> <p>Deposit a magnet beneath the stainless steel post.</p>	T 15 N	R 20 E	1/4		S 35	S 36			2009			
T 15 N	R 20 E												
1/4													
S 35	S 36												
2009													
51.50	Leave center line strip of highway, bears N. 70° W. and South.												
57.50	Enter heavy timber and dense undergrowth, edge bears N. 54° E and S. 54° W.												
72.00	Leave undergrowth; continue through heavy timber.												
80.00	<p>Point for the cor. of secs. 25, 26, 35 and 36.</p> <p>Set an iron post, 28 ins. long, 2½ ins. diam., 24 ins. in the ground, with brass cap mkd.</p> <div style="text-align: center;"> <table style="margin: auto;"> <tr><td>T 15 N</td><td>R 20 E</td></tr> <tr><td>S 26</td><td>S 25</td></tr> <tr><td colspan="2"> </td></tr> <tr><td>S 35</td><td>S 36</td></tr> <tr><td colspan="2"> </td></tr> <tr><td colspan="2">2009</td></tr> </table> </div> <p>from which</p> <p style="padding-left: 40px;">A green ash, 13 ins. diam., bears N. 22° E., 26 lks. dist., mkd. T15N R20E S25 BT.</p> <p style="padding-left: 40px;">A green ash, 23 ins. diam., bears S. 71¼° E., 37 lks. dist., mkd. T15N R20E S36 BT.</p> <p style="padding-left: 40px;">A green ash, 17 ins. diam., bears S. 64° W., 41 lks. dist., mkd. T15N R20E S35 BT.</p> <p style="padding-left: 40px;">A cottonwood, 13 ins. diam., bears N. 21¼° W., 36 lks. dist., mkd. T15N R20E S26 BT.</p>	T 15 N	R 20 E	S 26	S 25			S 35	S 36			2009	
T 15 N	R 20 E												
S 26	S 25												
S 35	S 36												
2009													



Subdivision of T. 15 N., R. 20 E., Principal Meridian, Montana

CHAINS	<p>Deposit a magnet beneath the iron post.</p> <hr/> <p>From the cor. of secs. 25, 30, 31, and 36, on the E. bdy. of the Tp., monumented with a sandstone, 8 x 5 x 5 ins. above ground, firmly set, mkd. with 1 notch on S and 5 notches on N edge, from which the original bearing tree</p> <p style="padding-left: 40px;">A green ash, 20 ins. diam., bears S. 15° E., 32 lks. dist., with healed blaze.</p> <p>At the corner point</p> <p>Set a stainless steel post, 30 ins. long, 2½ ins. diam., 23 ins. in the ground, and in a mound of stone, 2 ft. diam., to top, with brass cap mkd.</p> <div style="text-align: center; margin: 10px 0;"> <table style="margin: auto; border-collapse: collapse;"> <tr><td colspan="2">T 15 N</td></tr> <tr><td>R 20 E</td><td>R 21 E</td></tr> <tr><td style="border-right: 1px solid black;">S 25</td><td>S 30</td></tr> <tr><td style="border-right: 1px solid black;">S 36</td><td>S 31</td></tr> <tr><td colspan="2">2009</td></tr> </table> </div> <p>from which</p> <p style="padding-left: 40px;">A lodgepole pine, 12 ins. diam., bears N. 4° E., 41 lks. dist., mkd. T15N R21E S30 BT.</p> <p>Buried the sandstone alongside and deposit a magnet beneath the stainless steel post.</p> <p>N. 89°57' W., bet. secs. 25 and 36, posting and blazing true line.</p> <p>Over level bottom land, through scattering timber.</p> <p>16.20 Cherry Creek, 12 lks. wide, course NW.</p> <p>40.00 Point for the ¼ sec. cor. of secs. 25 and 36.</p> <p>Set an iron post, 28 ins. long, 2½ ins. diam., 24 ins. in the ground, with brass cap mkd.</p> <div style="text-align: center; margin: 10px 0;"> <table style="margin: auto; border-collapse: collapse;"> <tr><td colspan="2">T 15 N</td><td>R 20 E</td></tr> <tr><td colspan="2">S 25</td><td></td></tr> <tr><td>1/4</td><td colspan="2">_____</td></tr> <tr><td></td><td>S 36</td><td></td></tr> <tr><td></td><td>2009</td><td></td></tr> </table> </div> <p>from which</p> <p style="padding-left: 40px;">A green ash, 7 ins. diam., bears S. 65¼° W., 189 lks. dist., mkd. 1/4 S36 BT.</p>	T 15 N		R 20 E	R 21 E	S 25	S 30	S 36	S 31	2009		T 15 N		R 20 E	S 25			1/4	_____			S 36			2009	
T 15 N																										
R 20 E	R 21 E																									
S 25	S 30																									
S 36	S 31																									
2009																										
T 15 N		R 20 E																								
S 25																										
1/4	_____																									
	S 36																									
	2009																									



Subdivision of T. 15 N., R. 20 E., Principal Meridian, Montana

CHAINS	<p>A green ash, 8 ins. diam., bears N. <math>64\frac{3}{4}^{\circ}</math> W., 124 lks. dist., mkd. 1/4 S25 BT.</p> <p>Deposit a magnet beneath the iron post.</p>
80.00	<p>The cor. of secs. 25, 26, 35 and 36.</p> <hr style="width: 100%;"/> <p>N. <math>0^{\circ}01'</math> W., bet. secs. 25 and 26.</p> <p>Over level bottom land, through heavy timber.</p>
25.32	<p>Ordinary high water mark on the right bank of Yellowstone River, bears N. <math>81^{\circ}</math> E. and S. <math>81^{\circ}</math> W., course N. <math>80^{\circ}</math> E.; banks 2 to 12 ft. high; water is high at present stage and from 1 to 8 ft. deep; point for the meander cor. of secs. 25 and 26.</p> <p>Set an iron post, 28 ins. long, <math>2\frac{1}{2}</math> ins. diam., 24 ins. in the ground, with brass cap mkd.</p> <div style="text-align: center; margin: 10px 0;"> <p style="margin: 0;">MC</p> <p style="margin: 0;">S 26   S 25</p> <p style="margin: 0;">T 15 N   R 20 E</p> <p style="margin: 0;">2009</p> </div> <p>from which</p> <p>A stainless steel post, 30 ins. long, <math>2\frac{1}{2}</math> ins. diam., set 23 ins. in the ground and over a magnet, for a reference monument, bears S. <math>18\frac{1}{4}^{\circ}</math> E., 16 lks. dist., mkd. T15N R20E S25 MC RM 2009 and an arrow pointing to the cor.</p> <p>A green ash, 11 ins. diam., bears S. <math>74\frac{1}{2}^{\circ}</math> W., 25 lks. dist., mkd. T15N R20E S26 MC BT.</p> <p>Deposit a magnet beneath the iron post.</p>
49.46	<p>Ordinary high water mark on the left bank of Yellowstone River; bears S. <math>80^{\circ}</math> E. and S. <math>80^{\circ}</math> W., point for the meander cor. of secs. 25 and 26.</p> <p>Drove a metal fence post, 8 ft. long, 6 ft. in the ground; impractical for regulation post as cor. point falls on bank liable to destruction.</p> <p>from which</p> <p>A green ash, 10 ins. diam., bears N. <math>34\frac{1}{4}^{\circ}</math> E., 228 lks. dist., mkd. T15N R20E S25 MC BT.</p> <p>A stainless steel post, 30 ins. long, <math>2\frac{1}{2}</math> ins. diam., set 23 ins. in the ground and over a magnet, for a reference monument, bears N. <math>65^{\circ}</math> W., 50 lks. dist., with brass cap mkd. T15N R20E S26 MC RM 2009 and an arrow pointing to the cor.</p>



Subdivision of T. 15 N., R. 20 E., Principal Meridian, Montana

CHAINS	<p>Raise a mound of stone, 5 ft. base, 3 ft. high, 5 lks. dist., N. of cor.</p> <p>Enter scattering timber, edge bears N. 81° E. and S. 81° W., posting and blazing line.</p>																		
52.60	<p>Top of bluff, 20 ft. high, bears E and W; leave timber.</p>																		
63.80	<p>Telephone line, bears E and W.</p>																		
80.00	<p>Point for the cor. of secs. 23, 24, 25, and 26.</p> <p>Set an iron post, 28 ins. long, 2½ ins. diam., 24 ins. in the ground, with brass cap mkd.</p> <div style="text-align: center; margin: 10px 0;"> <table style="border-collapse: collapse; margin: auto;"> <tr> <td style="border-right: 1px solid black; padding: 2px 5px;">T 15 N</td> <td style="padding: 2px 5px;">R 20 E</td> </tr> <tr> <td style="border-right: 1px solid black; padding: 2px 5px;">S 23</td> <td style="padding: 2px 5px;">S 24</td> </tr> <tr> <td style="border-right: 1px solid black; padding: 2px 5px;">S 26</td> <td style="padding: 2px 5px;">S 25</td> </tr> <tr> <td colspan="2" style="padding: 2px 5px;">2009</td> </tr> </table> </div> <p>Deposit a magnet beneath the iron post.</p> <hr style="border: 0.5px solid black; margin: 10px 0;"/> <p>From the cor. of secs. 19, 24, 25, and 30, on the E. bdy. of the Tp., monumented with a sandstone, 12 x 9 x 5 ins. above ground, loosely set at the E. side of a small mound of stone, poorly mkd. with 4 notches on N. and 2 notches on S. edge.</p> <p>At the corner point</p> <p>Set an iron post, 28 ins. long, 2½ ins. diam., 24 ins. in the ground, with brass cap mkd.</p> <div style="text-align: center; margin: 10px 0;"> <table style="border-collapse: collapse; margin: auto;"> <tr> <td colspan="2" style="padding: 2px 5px;">T 15 N</td> </tr> <tr> <td style="border-right: 1px solid black; padding: 2px 5px;">R 20 E</td> <td style="padding: 2px 5px;">R 21 E</td> </tr> <tr> <td style="border-right: 1px solid black; padding: 2px 5px;">S 24</td> <td style="padding: 2px 5px;">S 19</td> </tr> <tr> <td style="border-right: 1px solid black; padding: 2px 5px;">S 25</td> <td style="padding: 2px 5px;">S 30</td> </tr> <tr> <td colspan="2" style="padding: 2px 5px;">2009</td> </tr> </table> </div> <p>Raise a mound of stone, 3 ft. base, 2 ft. high, 7 lks. dist., W. of cor.</p> <p>Bury the mkd. stone alongside and deposit a magnet beneath the iron post.</p> <p>N. 89°57' W., bet. secs. 24 and 25.</p> <p>Over level land.</p>	T 15 N	R 20 E	S 23	S 24	S 26	S 25	2009		T 15 N		R 20 E	R 21 E	S 24	S 19	S 25	S 30	2009	
T 15 N	R 20 E																		
S 23	S 24																		
S 26	S 25																		
2009																			
T 15 N																			
R 20 E	R 21 E																		
S 24	S 19																		
S 25	S 30																		
2009																			
38.00	<p>NE cor. of State Highway maintenance station building, bears South, 8.03 chs. dist.</p>																		
40.00	<p>Point for the ¼ sec. cor. of secs. 24 and 25.</p> <p>Set an iron post, 28 ins. long, 2½ ins. diam., 24 ins. in the ground, with brass cap mkd.</p>																		





## Subdivision of T. 15 N., R. 20 E., Principal Meridian, Montana

CHAINS	
	T 15 N   R 20 E S 24 1/4 ————— S 25 2009
	Set a pressure treated wood post, 7 ft. long, 8 x 6 ins. cross section, 3 ft. in the ground, at W. side of and deposit a magnet beneath the iron post.
70.00	Center line strip of U.S. Highway No. 87, asphalt surface, 40 lks. wide, bears S. 73° E. and N. 73° W.
80.00	The cor. of secs. 23, 24, 25, and 26.
	<hr/> EDITOR NOTE.— The field notes continue in the regular order and in the same form; the record of 3 miles omitted. <hr/>
	From the cor. of secs. 7, 12, 13, and 18, on the E. bdy. of the Tp., previously described.
	N. 89° 57' W., bet. secs. 12 and 13.
	Over nearly level land.
31.51	Intersect the NE bdy. of the Rancho San Blas grant.
	Set an iron post, 28 ins. long, 2½ ins. diam., 24 ins. in the ground, with brass cap mkd.
	T 15 N   R 20 E RSB \ S12 ————— LG \ S13 2009
	Raise a mound of stone, 3 ft. base, 2 ft. high, 5 lks. dist., E. of cor.
	Deposit a magnet beneath the iron post.
	From this point the 5th Mi. Cor. of the grant bdy. bears S. 32°59' E., 7.11 chs. dist., previously described.
	From this same point the 4½ Mi. Cor. of the grant bdy. bears N. 32°59' W., 32.89 chs. dist., previously described.
	Thence on a blank line across the grant.
40.00	Point for the ¼ sec. cor. of secs. 12 and 13; no permanent monument established.



Subdivision of T. 15 N., R. 20 E., Principal Meridian, Montana

<p>CHAINS 67.05</p>	<p>Intersect the SW bdy. of the grant.</p> <p>Set an iron post, 28 ins. long, 2½ ins. diam., 24 ins. in the ground, with brass cap mkd.</p> <div style="text-align: center; margin: 10px 0;"> </div> <p>Raise a mound of stone, 2 ft. base, 1½ ft. high, 7 lks. dist., W. of cor.</p> <p>Deposit a magnet beneath the iron post.</p> <p>From this point the 3 Mi. Cor. of the grant bdy. bears S. 19°30' E., 28.14 chs. dist., previously described.</p> <p>From this same point the 3½ Mi. Cor. of the grant bdy. bears N. 19°30' W., 11.86 chs. dist., previously described</p> <p>The cor. is located on the top of a ridge bearing S. 15° E. and N. 15° W.; thence over rough, rocky ground.</p>
<p>76.00</p>	<p>Begin descent over broken SW slope.</p>
<p>80.00</p>	<p>The cor. of secs. 11, 12, 13, and 14.</p> <hr style="border: 0.5px solid black; margin: 10px 0;"/> <p>N. 0°01' W., bet. secs. 11 and 12.</p> <p>Asc. over broken SW slope.</p>
<p>11.00</p>	<p>Top of ascent, bears S. 50° E. and N. 50° W.; thence over nearly level land.</p>
<p>36.58</p>	<p>Intersect the SW bdy. of the Rancho San Blas grant.</p> <p>Set an iron post, 28 ins. long, 2½ ins. diam., 24 ins. in the ground, with brass cap mkd.</p> <div style="text-align: center; margin: 10px 0;"> </div> <p>from which</p> <p style="text-align: center;">A juniper, 20 ins. diam., bears S. 34¼° W., 484 lks. dist., mkd. T15N R20E S11 BT.</p>



## Subdivision of T. 15 N., R. 20 E., Principal Meridian, Montana

CHAINS	
	<p>Raise a mound of stone, 2 ft. base, 1½ ft. high, 5 lks. dist., S. of cor.</p> <p>Deposit a magnet beneath the iron post.</p> <p>From this point the 3½ Mi. Cor. of the grant bdy. bears S. 19°30' E., 26.96 chs. dist., previously described.</p> <p>From this same point the Cor. No. 7 of the grant bdy. bears N. 19°30' W., 7.33 chs. dist., previously described.</p> <p>Thence on a blank line across the grant.</p>
40.00	Point for the ¼ sec. cor. of secs. 11 and 12; no permanent monument established.
44.23	<p>Intersect the NW bdy. of the grant.</p> <p>Set an iron post, 28 ins. long, 2½ ins. diam., 15 ins. in the ground to bedrock, encircled by a mound of stone, 4 ft. base, to top, with brass cap mkd.</p> <div style="text-align: center;"> <p>T 15 N   R 20 E</p> <p>S 11   S 12</p> <hr style="width: 50%; margin: 0 auto;"/> <p>RSB   LG</p> <p>2009</p> </div> <p>Deposit a granite stone, 10 x 7 x 6 ins., mkd. X, alongside the iron post, as a memorial.</p> <p>From this point the 4 Mi. Cor. of the grant bdy. bears N. 73°00' E., 3.15 chs. dist., previously described.</p> <p>From this same point the Cor. No. 7 of the grant bdy. bears S. 73°00' W., 2.56 chs. dist., previously described.</p> <p>Thence over rolling ground.</p>
60.80	Creek, 6 lks. wide, course SE.
80.00	<p>Point for the cor. of secs. 1, 2, 11, and 12.</p> <p>Falls on a rock slide, no permanent monument established.</p> <p>from which</p> <p style="padding-left: 40px;">A stainless steel post, 30 ins. long, 2½ ins. diam., 23 ins. in the ground and over a magnet, for a witness corner, bears N. 0°02' W., 100 lks. dist with brass cap mkd. WC T15N R20E S1 S2 S11 S12 2009 and an arrow point to the cor.</p> <p>from the witness corner</p>



Subdivision of T. 15 N., R. 20 E., Principal Meridian, Montana

CHAINS	<p>A live oak, 16 ins. diam., bears N. 24° E., 141 lks. dist., mkd. X at breast height and BT at base.</p> <p>An aspen, 15 ins. diam., bears S. 42° W., 32 lks. dist., mkd. X at breast height and BT at base, in bark.</p> <hr/> <p>From the cor. of secs. 1, 6, 7, and 12, on the E. bdy. of the Tp., monumented with a burr oak, 12 ins. diam., with healed blazes on NE, SE, SW, and NW sides, and with a mound of stone, 2 ft. base, 1½ ft. high, 10 lks. dist., W. of cor.</p> <p>from which new bearing objects</p> <p>A stainless steel post, 30 ins. long, 2½ ins. diam., set 23 ins. in the ground and over a magnet, for a reference monument, bears S. 83° W., 50 lks. dist., with brass cap mkd. T15N R20E S12 RM 2009 and an arrow pointing to the cor.</p> <p>A stainless steel post, 30 ins. long, 2½ ins. diam., set 23 ins. in the ground and over a magnet, for a reference monument, bears N. 7° W., 50 lks. dist., with brass cap mkd. T15N R20E S1 RM 2009 and an arrow pointing to the cor.</p> <p>N. 89°57' W., bet. secs. 1 and 12 posting and blazing line.</p> <p>Over rolling land.</p> <p>3.50 Enter grove of heavy timber, edge bears N and S. 20° W.</p> <p>40.00 Point for the ¼ sec. cor. of secs. 1 and 12.</p> <p>Set an iron post, 28 ins. long, 2½ ins. diam., 24 ins. in the ground, with brass cap mkd.</p> <div style="text-align: center; margin: 10px 0;"> <p>T 15 N R 20 E</p> <p>S 1</p> <p>1/4 —————</p> <p>S 12</p> <p>2009</p> </div> <p>from which</p> <p>A burr oak, 9 ins. diam., bears N. 19½° W., 22 lks. dist., mkd. 1/4 S1 BT.</p> <p>A burr oak, 11 ins. diam., bears S. 65¾° W., 129 lks. dist., mkd. 1/4 S12 BT.</p> <p>Deposit a magnet beneath the iron post.</p> <p>41.10 Ravine, course S. 20° W.</p>
--------	--



## Subdivision of T. 15 N., R. 20 E., Principal Meridian, Montana

CHAINS											
49.60	Ravine, course S. 30° W.										
69.00	Leave timber, edge bears NE and SE.										
80.00	The cor. of secs. 1, 2, 11, and 12.										
	_____										
	N. 0° 01' W., bet. secs. 1 and 2.										
	Desc. slightly over rolling land.										
40.00	Point for the ¼ sec. cor. of secs. 1 and 2.										
	Falls at an inaccessible point on a cliff, no permanent monument established.										
	from which										
	A stainless steel post, 30 ins. long, 2½ ins. diam., 23 ins. in the ground and over a magnet, for a witness corner, bears South, 50 lks. dist with brass cap mkd. WC T15N R20E 1/4 S1 S2 2009 and an arrow point to the cor.										
	from the witness corner.										
	A live oak, 19 ins. diam., bears N. 21° E., 53 lks. dist., mkd. X at breast height and BT at base.										
	A burr oak, 12 ins. diam., bears S. 46° W., 33 lks. dist., mkd. X at breast height and BT at base.										
	Raise a mound of stone, 3 ft. base, 2 ft. high, 5 lks. dist., W. of the witness cor.										
49.30	Arroyo, course N. 70° E.										
80.00	Intersect N. bdy. of the Tp. at the cor. of secs. 1, 2, 35, and 36, monumented with a limestone, 16 x 6 x 5 ins. above ground, loosely set, mkd. with 1 notch on E. and 5 notches on W. edge, with a small mound of stone, 2 ft. base, 1½ ft. high, 3 lks. dist., W. of cor.										
	At the cor. point										
	Set an iron post, 28 ins. long, 2½ ins. diam., 10 ins. in the ground to bedrock, encircled by a mound of stone, 4 ft. base, to top, with brass cap mkd.										
	<table style="margin: auto; border-collapse: collapse;"> <tr> <td style="padding: 0 5px;">T 16 N</td> <td style="border-left: 1px solid black; padding: 0 5px;">R 20 E</td> </tr> <tr> <td style="padding: 0 5px;">S 35</td> <td style="border-left: 1px solid black; padding: 0 5px;">S 36</td> </tr> <tr> <td style="border-top: 1px solid black; padding: 0 5px;">S 2</td> <td style="border-left: 1px solid black; border-top: 1px solid black; padding: 0 5px;">S 1</td> </tr> <tr> <td style="padding: 0 5px;">T 15 N</td> <td></td> </tr> <tr> <td style="padding: 0 5px;">2009</td> <td></td> </tr> </table>	T 16 N	R 20 E	S 35	S 36	S 2	S 1	T 15 N		2009	
T 16 N	R 20 E										
S 35	S 36										
S 2	S 1										
T 15 N											
2009											





Subdivision of T. 15 N., R. 20 E., Principal Meridian, Montana

CHAINS	<p>Bury the marked stone alongside and deposit a magnet beneath the iron post.</p> <hr/> <p>From the cor. of secs. 2, 3, 34, and 35, on the S. bdy. of the Tp., monumented with a sandstone, 14 x 8 x 8 ins. above ground, firmly set, mkd. with 2 notches on the E. and 4 notches on the W. edge, with a mound of stone, 2 ft. base, 1½ ft. high, 5 lks. dist., W. of cor.</p> <p>At the corner point</p> <p>Set an iron post, 28 ins. long, 2½ ins. diam., 27 ins. in the ground, and in a mound of stone, 2 ft. diam. to top, with brass cap mkd.</p> <div style="text-align: center; margin: 10px 0;"> <table style="border-collapse: collapse; margin: auto;"> <tr> <td style="border-right: 1px solid black; padding: 2px 5px;">T 15 N</td> <td style="padding: 2px 5px;">R 20 E</td> </tr> <tr> <td style="border-right: 1px solid black; padding: 2px 5px;">S 34</td> <td style="padding: 2px 5px;">S 35</td> </tr> <tr> <td style="border-right: 1px solid black; padding: 2px 5px;">S 3</td> <td style="padding: 2px 5px;">S 2</td> </tr> <tr> <td colspan="2" style="padding: 2px 5px;">T 14 N</td> </tr> <tr> <td colspan="2" style="padding: 2px 5px;">2009</td> </tr> </table> </div> <p>from which</p> <p style="margin-left: 40px;">A lodgepole pine, 12 ins. diam., bears N. 14° E., 74 lks. dist., mkd. T15N R20E S35 BT.</p> <p style="margin-left: 40px;">A lodgepole pine, 8 ins. diam., bears S. 81° E., 14 lks. dist., mkd. T14N R20E S2 BT.</p> <p style="margin-left: 40px;">A lodgepole pine, 10 ins. diam., bears S. 44° W., 43 lks. dist., mkd. T14N R20E S3 BT.</p> <p style="margin-left: 40px;">A spruce, 34 ins. diam., bears N. 31° W., 16 lks. dist., mkd. T15N R20E S34 BT.</p> <p>Rebuilt the mound of stone, 4 ft. base, 3 ft. high, 5 lks. dist., W. of cor.</p> <p>Bury the mkd. stone alongside and deposit a magnet beneath the iron post.</p> <p>N. 0°02' W., bet. secs. 34 and 35.</p> <p>Over level bottom land.</p>	T 15 N	R 20 E	S 34	S 35	S 3	S 2	T 14 N		2009	
T 15 N	R 20 E										
S 34	S 35										
S 3	S 2										
T 14 N											
2009											
40.00	<p>Point for the ¼ sec. cor. of secs. 34 and 35.</p> <p>Set a stainless steel post, 30 ins. long, 2½ ins. diam, 23 in. in the ground, with brass cap mkd.</p>										



Subdivision of T. 15 N., R. 20 E., Principal Meridian, Montana

CHAINS	<p style="text-align: center;">T 15 N   R 20 E 1/4 S 34   S 35 2009</p> <p>Raise a mound of stone, 4 ft. base, 3 ft. high, 7 lks. dist., W of cor.</p> <p>42.00    Leave bottom land, edge bears N. 70° E. and S. 70° W.; asc. sandy ridge.</p> <p>46.00    Top of windblown sandy ridge, bears N. 70° E. and S. 70° W.</p> <p>50.00    Foot of sandy ridge; thence over nearly level land.</p> <p>80.00    Point for the cor. of secs. 26, 27, 34, and 35.</p> <p>Set an iron post, 28 ins. long, 2½ ins. diam., in a concrete form, 8 ins. upper diam., 14 ins. lower diam., 30 ins. long, 24 ins. in the ground, with brass cap mkd.</p> <p style="text-align: center;">T 15 N   R 20 E S 27   S 26 S 34   S 35 2009</p> <p>Bury a magnet at N. side of concrete monument.</p> <hr/> <p>From the cor. of secs. 25, 26, 35 and 36.</p> <p>N. 89°57' W., bet. secs. 26 and 35.</p> <p>Over level bottom land, through heavy timber.</p> <p>13.73    Ordinary high water mark on the right bank of Yellowstone River, bears S. 20° E. and N. 20° W., course N. 20° W.; banks 2 to 10 ft. high; water is high at present stage and from 1 to 8 ft. deep; point for the meander cor. of secs. 26 and 35.</p> <p>Set an iron post, 28 ins. long, 2½ ins. diam., 24 ins. in the ground, with brass cap mkd.</p> <p style="text-align: center;">T 15 N S 26 MC ——— S 35 R 20 E 2009</p> <p>from which</p> <p style="text-align: center;">A green ash, 9 ins. diam., bears N. 49¼° E., 26 lks. dist., mkd. T15N R20E S26 MC BT.</p>
--------	---



Subdivision of T. 15 N., R. 20 E., Principal Meridian, Montana

CHAINS	<p>A stainless steel post, 30 ins. long, 2½ ins. diam., set 23 ins. in the ground and over a magnet, for a reference monument, bears S. 38½° E., 21 lks. dist., with brass cap mkd. T15N R20E S35 MC RM 2009 and an arrow pointing to the cor.</p> <p>Deposit a magnet beneath the iron post.</p>
31.91	<p>Ordinary high water mark on the left bank of Yellowstone River; bears S. 20° E. and N. 20° W., point for the meander cor. of secs. 26 and 35.</p> <p>Set an iron post, 28 ins. long, 2½ ins. diam., 23 ins. in the ground, with brass cap mkd.</p> <div style="text-align: center; margin: 10px 0;"> </div> <p>from which</p> <p>A stainless steel post, 30 ins. long, 2½ ins. diam., set 23 ins. in the ground and over a magnet, for a reference monument, bears S. 77° W., 52 lks. dist., mkd. T15N R20E S35 MC RM 2009 and an arrow pointing to the cor.</p> <p>A cottonwood, 33 ins. diam., bears N. 68° W., 20 lks. dist., mkd. T15N R20E S26 MC BT.</p> <p>Raise a mound of stone, 5 ft. base, 3 ft. high, 5 lks. dist., W. of cor.</p> <p>Deposit a magnet beneath the iron post.</p> <p>Asc. gradually through scattering timber.</p>
37.50	<p>Leave timber.</p>
40.00	<p>Point for the ¼ sec. cor. of secs. 26 and 35.</p> <p>Set a stainless steel post, 30 ins. long, 2½ ins. diam., 23 ins. in the ground, with brass cap mkd.</p> <div style="text-align: center; margin: 10px 0;"> </div> <p>from which</p> <p>A green ash, 14 ins. diam., bears N. 28¾° E., 328 lks. dist., mkd. 1/4 S26 BT.</p>



## Subdivision of T. 15 N., R. 20 E., Principal Meridian, Montana

CHAINS	<p>A green ash, 9 ins. diam., bears S. 78° E., 278 lks. dist., mkd. 1/4 S35 BT.</p> <p>Deposit a magnet beneath the stainless steel post.</p>										
70.50	<p>Center line strip of State Highway No. 25, asphalt surface, 35 lks. wide, bears S. 68° E. and N. 68° W.</p>										
80.00	<p>The cor. of secs. 26, 27, 34, and 35.</p> <hr/> <p>EDITOR NOTE.— The field notes continue in the regular order and in the same form; the record of 31 miles is omitted.</p> <hr/> <p>From the cor. of secs. 5, 6, 31, and 32, on the S. bdy. of the Tp., monumented with a limestone, 15 x 8 x 6 ins., lying on the surface at E. side of a small mound of stone, poorly marked with 5 notches on one edge and 1 notch on the opposite edge.</p> <p>At the corner point</p> <p>Set an iron post, 28 ins. long, 2½ ins. diam., 24 ins. in the ground, with brass cap mkd.</p> <div style="text-align: center;"> <table style="border-collapse: collapse; margin: auto;"> <tr> <td style="padding: 0 5px;">T 15 N</td> <td style="border-left: 1px solid black; padding: 0 5px;">R 20 E</td> </tr> <tr> <td style="padding: 0 5px;">S 31</td> <td style="border-left: 1px solid black; padding: 0 5px;">S 32</td> </tr> <tr> <td style="border-top: 1px solid black; padding: 0 5px;">S 6</td> <td style="border-left: 1px solid black; border-top: 1px solid black; padding: 0 5px;">S 5</td> </tr> <tr> <td colspan="2" style="text-align: center; padding: 5px 0;">T 14 N</td> </tr> <tr> <td colspan="2" style="text-align: center; padding: 5px 0;">2009</td> </tr> </table> </div> <p>Raise a mound of stone, 4 ft. base, 2 ft. high, 7 lks. dist., W. of cor.</p> <p>Bury the mkd. stone alongside and deposit a magnet beneath the iron post.</p> <p>N. 0°05' W., bet. secs. 31 and 32.</p> <p>Over level land.</p>	T 15 N	R 20 E	S 31	S 32	S 6	S 5	T 14 N		2009	
T 15 N	R 20 E										
S 31	S 32										
S 6	S 5										
T 14 N											
2009											
40.00	<p>Point for the ¼ sec. cor. of secs. 31 and 32.</p> <p>Set a brass tablet, 3¼ ins. diam., 3½-in. stem, in a cylindrical concrete form, 36 ins. long, 6 ins. diam., 24 ins. in the ground, with top mkd.</p> <div style="text-align: center;"> <table style="border-collapse: collapse; margin: auto;"> <tr> <td style="padding: 0 10px;">T 15 N</td> <td style="padding: 0 10px;">R 20 E</td> </tr> <tr> <td colspan="2" style="text-align: center; padding: 5px 0;">1/4</td> </tr> <tr> <td style="padding: 0 5px;">S 31</td> <td style="border-left: 1px solid black; padding: 0 5px;">S 32</td> </tr> <tr> <td colspan="2" style="text-align: center; padding: 5px 0;">2009</td> </tr> </table> </div> <p>Bury 6 fragments of blue crockery at the base of the concrete monument.</p>	T 15 N	R 20 E	1/4		S 31	S 32	2009			
T 15 N	R 20 E										
1/4											
S 31	S 32										
2009											



Subdivision of T. 15 N., R. 20 E., Principal Meridian, Montana

CHAINS 80.00	<p>Point for the cor. of secs. 29, 30, 31, and 32.</p> <p>Set an iron post, 28 ins. long, 2½ ins. diam., 24 ins. in the ground, with brass cap mkd.</p> <div style="text-align: center; margin: 10px 0;"> <table style="border-collapse: collapse; margin: auto;"> <tr> <td style="border-right: 1px solid black; padding: 2px 5px;">T 15 N</td> <td style="padding: 2px 5px;">R 20 E</td> </tr> <tr> <td style="border-right: 1px solid black; padding: 2px 5px;">S 30</td> <td style="padding: 2px 5px;">S 29</td> </tr> <tr> <td style="border-right: 1px solid black; padding: 2px 5px;">S 31</td> <td style="padding: 2px 5px;">S 32</td> </tr> <tr> <td colspan="2" style="padding: 2px 5px;">2009</td> </tr> </table> </div> <p>Raise a mound of stone, 3 ft. base, 2 ft. high, 10 lks. dist., W. of cor.</p> <p>Deposit a magnet beneath the iron post.</p> <hr style="width: 80%; margin: 10px auto;"/> <p>From the cor. of secs. 28, 29, 32, and 33.</p> <p>N. 89°57' W., bet. secs. 29 and 32.</p> <p>Over level land.</p>	T 15 N	R 20 E	S 30	S 29	S 31	S 32	2009	
T 15 N	R 20 E								
S 30	S 29								
S 31	S 32								
2009									
14.50	Base of slope, edge bears N. 30° E. and S. 30° W.								
16.50	Top of slope.								
28.50	Spring, bears South, 2.50 chs. dist., course SE.								
40.00	<p>Point for the ¼ sec. cor. of secs. 29 and 32.</p> <p>Set a brass tablet, ¾ ins. diam., 3½-in. stem, in a cylindrical concrete form, 30 ins. long, 6 ins. diam., 24 ins. in the ground, with top mkd.</p> <div style="text-align: center; margin: 10px 0;"> <table style="border-collapse: collapse; margin: auto;"> <tr> <td style="padding: 2px 5px;">T 15 N</td> <td style="padding: 2px 5px;">R 20 E</td> </tr> <tr> <td style="padding: 2px 5px;">S 29</td> <td style="padding: 2px 5px;">S 32</td> </tr> <tr> <td style="padding: 2px 5px;">1/4</td> <td style="padding: 2px 5px;">2009</td> </tr> </table> </div> <p>Bury a cast-iron stove lid, 8 ins. diam., ½ in. thick, at the base of the concrete monument.</p>	T 15 N	R 20 E	S 29	S 32	1/4	2009		
T 15 N	R 20 E								
S 29	S 32								
1/4	2009								
80.00	<p>The cor. of secs. 29, 30, 31, and 32.</p> <hr style="width: 80%; margin: 10px auto;"/> <p>N. 89°57' W., bet. secs. 30 and 31.</p> <p>Over level land.</p>								
40.00	Point for the ¼ sec. cor. of secs. 30 and 31.								



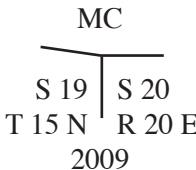


## Subdivision of T. 15 N., R. 20 E., Principal Meridian, Montana

CHAINS	<p>Set an iron post, 28 ins. long, 2½ ins. diam., 24 ins. in the ground, with brass cap mkd.</p> <p style="text-align: center;">T 15 N R 20 E S 30 1/4 ————— S 31 2009</p> <p>from which</p> <p style="padding-left: 40px;">A blue spruce, 18 ins. diam., bears N. 12° E., 28 lks. dist., mkd. 1/4 S30 BT.</p> <p style="padding-left: 40px;">An alder, 14 ins. diam., bears S. 67° E., 48 lks. dist., mkd. 1/4 S 31 BT, in bark.</p> <p>Deposit a magnet beneath the iron post.</p>
78.37	<p>Intersect the W. bdy. of the Tp., at the cor. of secs. 25, 30, 31, and 36, identified by traces of four pits, one in each sec., NE, SE, SW, and NW, with a part of the original corner stake bearing fragmentary scribe marks lying in the SE pit.</p> <p>At the corner point</p> <p>Set an iron post, 28 ins. long, 2½ ins. diam., 24 ins. in the ground, with brass cap mkd.</p> <p style="text-align: center;">T 15 N R 19 E   R 20 E S 25   S 30 ----- S 36   S 31 2009</p> <p>Deposit a sandstone, 6 x 6 x 6 ins., mkd. X at the base of the iron post, as a memorial, and bury the old stake alongside.</p> <hr/> <p>EDITOR NOTE.— The field notes continue in the regular order and in the same form; the record of 3 miles is omitted.</p> <hr/> <p>N. 0°05' W., bet. secs. 19 and 20.</p> <p>Desc. over rocky N slope.</p>
2.00	Base of slope, bears N. 80° E. and S. 80° W.
40.00	<p>Point for the ¼ sec. cor. of secs. 19 and 20.</p> <p>Set an iron post, 28 ins. long, 2½ ins. diam., 24 ins. in the ground, with brass cap mkd.</p>



Subdivision of T. 15 N., R. 20 E., Principal Meridian, Montana

CHAINS	
	T 15 N R 20 E 1/4 S 19   S 20 2009
	Raise a mound of stone, 4 ft. base, 2 ft. high, 5 lks. dist., W. of cor.  Deposit a magnet beneath the iron post.
44.50	Ordinary high water mark on the south bank of Lins Lake, bears East and N. 74° W.; point for the meander cor. of secs. 19 and 20.  Set an iron post, 28 ins. long, 2½ ins. diam., 24 ins. in the ground, with brass cap mkd.
	MC 
	from which  A box elder, 8 ins. diam., bears S. 77½° E., 221 lks. dist., mkd. T15N R20E S20 MC BT.  A stainless steel post, 30 ins. long, 2½ ins. diam., set 23 ins. in the ground and over a magnet, for a reference monument, bears West, 327 lks. dist., mkd. T15N R20E S19 MC RM 2009 and an arrow pointing to the cor.  Deposit a magnet beneath the iron post.
	<hr/> From the cor. of secs. 16, 17, 20, and 21.  N. 89°57' W., bet. secs. 17 and 20.  Desc. gradually over gently rolling land.
20.50	Road, ungraded dirt, 15 lks. wide, bears N and S.
28.70	Ditch, bears N. 30° E. and S. 30° W., course S. 30° W.; enter cultivated field, edge bears same as ditch.
36.50	Leave field; enter heavy timber, edge bears N. 30° E. and S. 30° W.
40.00	Point for the ¼ sec. cor. of secs. 17 and 20.  Set an iron post, 28 ins. long, 2½ ins. diam., 24 ins. in the ground, with brass cap mkd.



Subdivision of T. 15 N., R. 20 E., Principal Meridian, Montana

CHAINS	<div style="text-align: center; margin-bottom: 20px;"> <p>T 15 N   R 20 E</p> <p>      S 17</p> <p>1/4 ———</p> <p>      S 20</p> <p>      2009</p> </div> <p>from which</p> <p style="margin-left: 40px;">A green ash, 13 ins. diam., bears S. 70½° W., 28 lks. dist., mkd. 1/4 S20 BT.</p> <p style="margin-left: 40px;">A box elder, 12 ins. diam., bears N. 22¼° W., 119 lks. dist., mkd. 1/4 S17 BT.</p> <p>43.20 Ordinary high water mark on the east bank of Lins Lake, bears N. 19° E. and S. 39¾° W.; point for the meander cor. of secs. 17 and 20, occupied by a green ash, 8 ins. diam., mkd.</p> <p style="margin-left: 40px;">S17 on N, T15N R20E on E, S20 on S, and MC on W side;</p> <p>from which</p> <p style="margin-left: 40px;">A green ash, 10 ins. diam., bears N. 40¾° E., 20 lks. dist., mkd. T15N R20E S17 MC BT.</p> <p style="margin-left: 40px;">A stainless steel post, 30 ins. long, 2½ ins. diam., set 23 ins. in the ground and over a magnet, for a reference monument, bears S. 62¼° E., 114 lks. dist., mkd. T15N R20E S20 MC RM 2009 and an arrow pointing to the cor.</p> <hr style="width: 60%; margin: 20px auto;"/> <p>In order to establish the line bet. secs. 18 and 19, which crosses Ivy Island in Lins Lake, the meander cor. on the SE bank of the island was determined from the cor. of secs. 19, 20, 29, and 30, at N. 0°05' W., 80 chs. dist., thence N. 89°57' W. to intersect with the ordinary high water mark,</p> <p>Point for the meander cor. of secs. 18 and 19, on the SE bank of Ivy Island at the ordinary high water mark; the bank bears N. 47¼° E. and S. 47¼° W.</p> <p>Set an iron post, 28 ins. long, 2½ ins. diam., 24 ins. in the ground, with brass cap mkd.</p> <div style="text-align: center; margin-top: 20px;"> <p>T 15 N</p> <p>      S 18</p> <p>      ——— MC</p> <p>      S 19</p> <p>R 20 E</p> <p>      2009</p> </div>
--------	---



Subdivision of T. 15 N., R. 20 E., Principal Meridian, Montana

CHAINS	<p>from which</p> <p style="padding-left: 40px;">A green ash, 8 ins. diam., bears S. <math>78\frac{3}{4}^{\circ}</math> W., 127 lks. dist., mkd. T15N R20E S19 MC BT.</p> <p style="padding-left: 40px;">A burr oak, 9 ins. diam., bears N. <math>16\frac{1}{4}^{\circ}</math> W., 29 lks. dist., mkd. T15N R20E S18 MC BT.</p> <p>Deposit a magnet beneath the iron post.</p> <p>From this point the meander cor. of 19 and 20 on the south bank of Lins Lake bears S. <math>5^{\circ}20'30''</math> E., 35.66 chs. dist.</p> <p>Thence N. <math>89^{\circ}57'</math> W., bet. secs. 18 and 19.</p> <p>Over level land, across Ivy Island.</p> <p>4.11 Ordinary high water mark on the SW bank of the island, bears S. <math>53^{\circ}</math> E.; and N. <math>5\frac{1}{2}^{\circ}</math> W., point for the meander cor. of secs. 18 and 19.</p> <p>Set an iron post, 28 ins. long, <math>2\frac{1}{2}</math> ins. diam., 24 ins. in the ground, with brass cap mkd.</p> <div style="text-align: center; margin: 10px 0;"> </div> <p>Raise a mound of stone, 6 ft. base, 3 ft. high, 10 lks. dist., E of cor.</p> <p>Deposit a magnet beneath the iron post.</p> <hr style="width: 60%; margin: 10px auto;"/> <p style="padding-left: 40px;">EDITOR NOTE.— The line bet. secs. 8 and 17 is established next by running from the cor. of secs. 8, 9, 16 and 17, N. <math>89^{\circ}57'</math> W., 80.00 chs. dist., with the <math>\frac{1}{4}</math> sec. cor. at 40.00 chs.</p> <p style="padding-left: 40px;">The line bet. secs. 17 and 18 is then established by running from the cor. of secs. 7, 8, 17, and 18, S. <math>0^{\circ}05'</math> E., 20.19 chs. dist., to the ordinary high water mark on the north bank of Lins Lake.</p> <p style="padding-left: 40px;">The resultant line across Lins Lake is N.<math>0^{\circ}05'</math>W. 95.31 chs. dist.</p> <p style="padding-left: 40px;">The line bet. secs. 7 and 18 is established by the random and true line method with angle points on the E. and W. bdrs. of the Lake City Townsite. The field notes call for the <math>\frac{1}{4}</math> sec. cor. at 40.00 chs. dist. from the east.</p>
--------	---



Subdivision of T. 15 N., R. 20 E., Principal Meridian, Montana

CHAINS

The remaining 4 miles of the regular subdivisional lines are established in the normal manner, and at the ¼ sec. cor. on the line bet. secs. 5 and 8 the bearing and dist. to the U.S. Mineral Monument in the SW¼ of the SE¼ of sec. 5 is determined and recorded.

---

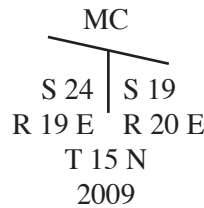
Meanders of Lins Lake  
T. 15 N., R. 20 E., Principal Meridian, Montana

---

From the meander cor. of secs. 19 and 24, on the W. bdy. of the Tp. and the south bank of Lins Lake, monumented with a limestone, 14 x 8 x 8 ins. above ground, firmly set, mkd. MC on N and with 3 grooves on S face, with a mound of stone, 2 ft. base, 1½ ft. high, 10 lks. dist., S. of cor.

At the corner point

Set a stainless steel post, 30 ins. long, 2½ ins. diam., 23 ins. in the ground, with brass cap mkd.



from which

A stainless steel post, 30 ins. long, 2½ ins. diam., set 23 ins. in the ground and over a magnet, for a reference monument, bears S. 1° E., 50 lks. dist., mkd. T15N R20E S19 MC RM 2009 and an arrow pointing to the cor.

Buried the mkd. stone alongside the cor. and deposit a magnet beneath the stainless steel post.

Thence with the meanders of Lins Lake in sec. 19.

Along the ordinary high water mark and the bottom edge of a well-defined bank, 2 to 4 ft. high, on the upper side of a gravelly beach.

- S. 56°00' E., 7.20 chs.
- S. 46°30' E., 3.40 chs.
- S. 44°00' E., 2.40 chs.
- S. 43°15' E., 5.70 chs.
- S. 45°15' E., 4.40 chs.
- S. 44°45' E., 5.80 chs.

On this course the bank increases in height from 3 to 15 ft.; the beach becomes narrow and rocky.





Meanders of Lins Lake  
T. 15 N., R. 20 E., Principal Meridian, Montana

CHAINS	<p>S. 45°30' E., 2.00 chs. S. 49°30' E., 4.00 chs.      On this course the bank becomes a nearly vertical cliff, 35 ft. above ordinary high water mark.</p> <p>S. 54°15' E., 5.00 chs. S. 67°45' E., 2.00 chs. S. 78°06' E., 6.72 chs.      On this course leave cliff; bank gradually becomes lower to a height of about 4 ft.</p> <p>N. 85°22' E., 1.88 chs. N. 77°45' E., 11.00 chs. S. 77°45' E., 7.20 chs. S. 73°47' E., 21.20 chs.      The meander cor. of secs. 19 and 20 on the south bank, previously described.</p> <hr/> <p style="text-align: center;">EDITOR NOTE.— The meanders continue around the north bank of the lake through secs. 20, 17, and 18 in the same form; the record is omitted.</p> <hr/> <p style="text-align: center;">Meanders of Lins Lake – Diamond Rock T. 15 N., R. 20 E., Principal Meridian, Montana</p> <hr/> <p>The meanders of a small island called Diamond Rock, in Lins Lake, in sec. 18, was begun at the meander cor. of secs. 19 and 24, on the W. bdy. of the Tp. and the south bank of the lake, previously described.</p> <p>N. 71°30' E., on a connecting line.</p> <p>Over water.</p> <p>21.45      SW bank of Diamond Rock at ordinary high water mark; point for auxiliary meander cor. in sec. 18.</p> <p>Set a brass tablet, 3¼ ins. diam., 3½-in. stem, in drill hole in solid rock, with top mkd.</p> <p style="text-align: center;">AMC T 15 N   R 20 E S 18 2009</p> <p>Raise a mound of stone, 3 ft. base, 2 ft. high, 10 lks. dist., NE of cor.</p> <p>From this point the meander cor. of secs. 13 and 18, on the W. bdy. of the Tp. and on the north bank of the lake, bears N. 25°02' W., 48.06 chs. dist. The meander cor. is mkd. by a juniper, 14 ins. diam., with healed blazed on N and S sides.</p> <p>Thence with the meanders of the island.</p>
--------	--



Meanders of Lins Lake – Diamond Rock  
T. 15 N., R. 20 E., Principal Meridian, Montana

CHAINS

Along the top of a low but well-defined bank, on the upper side of a gravelly beach.

N. 16°30' W., 2.70 chs.

N. 61°15' E., 2.90 chs.

S. 48°30' E., 3.50 chs.

S. 33°00' W., 2.20 chs.

N. 86°46' W., 3.20 chs.

The auxiliary meander cor. and place of beginning.

---

Meanders of Lins Lake – Ivy Island  
T. 15 N., R. 20 E., Principal Meridian, Montana

EDITOR NOTE.— The record of the meanders of Ivy Island is omitted. The detail of the improvements on the island is carried to the general description at the close of the field notes.

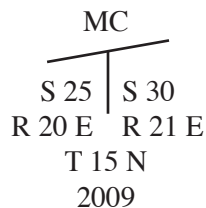
---

Meanders of Yellowstone River  
T. 15 N., R. 20 E., Principal Meridian, Montana

From the meander cor. of secs. 25 and 30, on the E. bdy. of the Tp. and the right bank of the Yellowstone River, monumented with a sandstone, 16 x 9 x 7 ins. above ground, firmly set, mkd. MC on N and with 2 grooves on S face, with a mound of stone, 2 ft. base, 1½ ft. high, 5 lks. dist., S. of cor.

At the corner point

Set a stainless steel post, 30 ins. long, 2½ ins. diam., 23 ins. in the ground, with brass cap mkd.



from which

A stainless steel post, 30 ins. long, 2½ ins. diam., set 23 ins. in the ground and over a magnet, for a reference monument, bears S. ¼° W., 50 lks. dist., mkd. T15N R20E S25 MC RM 2009 and an arrow pointing to the cor.

Buried the mkd. stone alongside the cor. and deposit a magnet beneath the stainless steel post.



Meanders of Yellowstone River  
T. 15 N., R. 20 E., Principal Meridian, Montana

CHAINS	<p>Thence upstream with the meanders of the right bank of the river, in sec. 25; over bottom land, along a well-defined cutbank, 2 to 12 ft. high, through heavy timber.</p> <p>S. 85°00' W., 13.00 chs.                  S. 72°00' W., 7.10 chs.                  S. 64°30' W., 13.00 chs.                  S. 40°30' W., 5.40 chs.      At end of course, mouth of Cherry Creek, 14 lks. wide.                  S. 77°45' W., 7.00 chs.                  N. 76°00' W., 7.40 chs.                  S. 80°00' W., 12.00 chs.      At end of course, the downstream end of an unsurveyed island bears N.10°W., 10 chs. dist.                    S. 81°07' W., 19.45 chs.      At 17 chs. dist. on this course, the upstream end of the same unsurveyed island bears N.10°W., 10 chs. dist.                    At end of course, the meander cor. of secs. 25 and 26, previously described.</p> <hr/> <p style="text-align: center;">EDITOR NOTE.— The meanders of the right bank are continued upstream in secs. 26 and 35, to the S. bdy. of the Tp. The field notes then show the meanders of the left bank running downstream in secs. 35, 26, and 25, in the same form. The record is omitted.</p> <hr/> <p style="text-align: center;">Meanders of Clear Lake T. 15 N., R. 20 E., Principal Meridian, Montana</p> <hr/> <p style="text-align: center;">EDITOR NOTE.— The record of the meanders of Clear Lake is omitted.</p> <hr/> <p style="text-align: center;">Subdivision of Section 7, T. 15 N., R. 20 E., Principal Meridian, Montana</p> <hr/> <p>From the ¼ sec. cor. of secs. 7 and 18.</p> <p>N. 0°05' W., on the N. and S. center line of sec. 7.</p> <p>40.01      Point for the center ¼ sec. cor. of sec. 7, at intersection with the E. and W. center line, identical with Angle Point No. 2, Lake City Townsite, hereinafter surveyed.</p> <p>Set an iron post, 28 ins. long, 2½ ins. diam., in a concrete form, 8 ins. upper diam., 14 ins. lower diam., 30 ins. long, 24 ins. in the ground, with brass cap mkd.</p>
--------	---



Subdivision of Section 7,  
T. 15 N., R. 20 E., Principal Meridian, Montana

CHAINS	
	T 15 N R 20 E C1/4 S 7 <hr style="width: 50%; margin: auto;"/> AP 2 LCTS 2009
	Deposit a magnet beneath the iron post.
80.02	The ¼ sec. cor. of secs. 6 and 7.
	<hr style="width: 80%; margin-left: 20px;"/> From the ¼ sec. cor. of secs. 7 and 8.  N. 89°57' W., on the E. and W. center line of sec. 7.
2.00	Center line strip of U.S. Highway No. 87, asphalt surface, 40 lks. wide, bears S. 30° E. and N. 30° W.
25.80	Point for Angle Point No. 3, Lake City Townsite, hereinafter surveyed.
	Set an iron post, 28 ins. long, 2½ ins. diam., in a concrete form, 8 ins. upper diam., 14 ins. lower diam., 30 ins. long, 24 ins. in the ground, with brass cap mkd.
	S 7 C ——— C   AP 3 LCTS 2009
	Deposit a magnet beneath the iron post.
	From this point the preliminary NE cor. monument bears North, 7 lks. dist., a limestone, 21 x 14 x 9 ins. above ground, firmly set, mkd. NE COR LC on SW side. The stone is now removed and buried alongside the iron post as a memorial.
	Continue on the E. and W. center line, along the N. bdy. of the townsite, posting and blazing true line.
40.00	The center ¼ sec. cor. of sec. 7, identical with Angle Point No. 2, Lake City Townsite, hereinafter surveyed.
60.00	Point for the center west 1/16 sec. cor. of sec. 7, identical with Angle Point No. 1, Lake City Townsite, hereinafter surveyed.
	Set an iron post, 28 ins. long, 2½ ins. diam., in a concrete form, 8 ins. upper diam., 14 ins. lower diam., 30 ins. long, 24 ins. in the ground, with brass cap mkd.



Subdivision of Section 7,  
T. 15 N., R. 20 E., Principal Meridian, Montana

CHAINS	
77.94	<div style="text-align: center;"> <p>W 1/16</p> <p>C ——— C</p> <p>     </p> <p>    AP 1</p> <p>    LCTS</p> <p>    S 7</p> <p>    2009</p> </div> <p>Deposit a magnet beneath the iron post.</p> <p>From this point the preliminary NW cor. monument bears N. 81°45' E., 14 lks. dist., an oak post, 4 ins. sq., 4 ft. long, mkd. NW COR LC on SE side. The post is now removed and reset, inverted, alongside the iron post.</p> <p>Continue on the E. and W. center line of sec. 7.</p> <p>The ¼ sec. cor. of secs. 7 and 12, on the W. bdy. of the Tp., monumented with a limestone, 12 x 10 x 8 ins. above ground, firmly set, mkd. ¼ on W face, with a mound of stone, 2 ft. base, 1½ ft. high, 10 lks. dist., W. of cor.</p> <p>At the corner point</p> <p>Set a stainless steel post, 30 ins. long, 2½ ins. diam., 23 ins. in the ground, with brass cap mkd.</p>
40.00	<div style="text-align: center;"> <p>T 15 N</p> <p>R 19 E R 20 E</p> <p>    1/4</p> <p>    S 12   S 7</p> <p>    2009</p> </div> <p>Raise a mound of stone, 4 ft. base, 2 ft. high, 5 lks. dist., W. of cor.</p> <p>Deposit a magnet beneath the stainless steel post.</p> <hr/> <p>From the W. 1/16 sec. cor. of secs. 7 and 18, identical with Angle Point No. 8, Lake City Townsite, hereinafter surveyed.</p> <p>N. 0°05' W., on the N. and S. center line of the SW¼ of sec. 7, identical with the W. bdy. of the townsite, posting and blazing true line.</p> <p>The center west 1/16 sec. cor. of sec. 7, identical with Angle Point No. 1, Lake City Townsite, hereinafter surveyed.</p> <hr/>





Subdivision of Section 18,  
T. 15 N., R. 20 E., Principal Meridian, Montana

CHAINS	
	<p>From the W. 1/16 sec. cor. of secs. 7 and 18, identical with Angle Point No. 8, Lake City Townsite, hereinafter surveyed.</p> <p>S. 0°05' E., parallel with the E. boundary of the section, on the N. and S. center line of the NW¼ of sec. 18, identical with the W. bdy. of Lake City Townsite, hereinafter surveyed, posting and blazing true line.</p>
27.50	Center of tracks of the Montana and Manitoba Railroad, bears N. 60° E. and S. 70° W.
29.50	<p>Ordinary high water mark on the north bank of Lins Lake, bears N. 70° E. and S. 70° W, identical with Angle Point No. 7, Lake City Townsite, hereinafter surveyed, and point for the special meander cor.</p> <p>Set an iron post, 28 ins. long, 2½ ins. diam., in a concrete form, 8 ins. upper diam., 14 ins. lower diam., 30 ins. long, 24 ins. in the ground, with brass cap mkd.</p> <div style="text-align: center; margin: 20px 0;"> </div> <p>from which</p> <p style="padding-left: 40px;">A stainless steel post, 30 ins. long, 2½ ins. diam., set 23 ins. in the ground and over a magnet, for a reference monument, bears N. ¼° W., 75 lks. dist., mkd. S18 MC RM 2009 and an arrow pointing to the cor.</p> <p>Deposit magnets beneath the posts.</p> <p>From this point the preliminary SW cor. monument bears East, 4 lks. dist., a limestone, 16 x 8 x 6 ins. above ground, firmly set, mkd. SW COR LC on NE side. The stone is now removed and buried alongside the iron post as a memorial.</p> <hr style="width: 60%; margin: 20px auto;"/> <p style="text-align: center;">Subdivision of Section 33, T. 15 N., R. 20 E., Principal Meridian, Montana</p> <hr style="width: 60%; margin: 20px auto;"/> <p>From the ¼ sec. cor. of secs. 4 and 33, on the S. bdy. of the Tp., monumented with a granite outcrop, 10 x 6 x 5 ft above ground, mkd. XBO near upper right edge.</p>



Subdivision of Section 33,  
T. 15 N., R. 20 E., Principal Meridian, Montana

CHAINS	<p>from which a new bearing object</p> <p style="text-align: center;">A stainless steel post, 30 ins. long, 2½ ins. diam., set 23 ins. in the ground and over a magnet, for a reference monument, bears N. 1° E., 50 lks. dist., mkd. T15N R20E 1/4 S33 RM 2009 and an arrow pointing to the cor.</p> <p>N. 0°03' W., on the N. and S. center line of sec. 33.</p> <p>Over level land.</p>
20.45	<p>Ordinary high water mark on the south bank of Clear Lake bears N. 70° E. and S. 60° W.; across lake.</p>
56.00	<p>Ordinary high water mark on the north bank of Clear Lake, bears S. 53° E. and S. 52° W.; point for the special meander cor.</p> <p>Set an iron post, 28 ins. long, 2½ ins. diam., 24 ins. in the ground, with brass cap mkd.</p> <div style="text-align: center; margin: 10px 0;"> <pre> C   S   33   ---   C   SMC 2009                     </pre> </div> <p>Raise a mound of stone, 2 ft. base, 1½ ft. high, 10 lks. dist., N of cor.</p> <p>Over level ground.</p>
76.50	<p>Creek, 8 lks. wide, course S. 80° E.</p>
80.00	<p>The ¼ sec. cor. of secs. 28 and 33.</p> <hr style="border: 0.5px solid black; margin: 10px 0;"/> <p style="text-align: center;">Survey of Lake City Townsite T. 15 N., R. 20 E., Principal Meridian, Montana</p> <hr style="border: 0.5px solid black; margin: 10px 0;"/> <p>From Angle Point No. 1, Lake City Townsite, identical with the center west 1/16 sec. cor. of sec. 7, previously described.</p> <p>S. 89°57' E., on the N. boundary of the Townsite, identical with the E. and W. center line of sec. 7.</p>
20.00	<p>Angle Point No. 2, Lake City Townsite, identical with the center ¼ sec. cor. of sec. 7, previously described.</p>
34.20	<p>Angle Point No. 3, Lake City Townsite, previously described.</p>



Survey of Lake City Townsite  
T. 15 N., R. 20 E., Principal Meridian, Montana

CHAINS	
40.00	<p style="text-align: center;">—————</p> <p>S. 0°05' E., on the E. bdy. of the townsite, posting and blazing true line.</p> <p>Angle Point No. 4, Lake City Townsite, at intersection with the line bet. secs. 7 and 18, previously described.</p> <p style="text-align: center;">—————</p> <p>Thence in sec. 18.</p> <p>S. 0°05' E., on the E. bdy. of the townsite, posting and blazing true line.</p>
5.10	Center of tracks of the Montana and Manitoba Railroad, bears N. 70° E. and S. 70° W.
7.53	<p>Ordinary high water mark on the north bank of Lins Lake; point for meander cor. in sec. 18, identical with Angle Point No. 5, Lake City Townsite.</p> <p>Set an iron post, 28 ins. long, 2½ ins., diam., in a concrete form, 8 ins. upper diam., 14 ins. lower diam., 30 ins. long, 24 ins. in the ground, with brass cap mkd.</p> <div style="text-align: center;"> <p>S 18 LCTS AP 5 MC 2009</p> </div> <p>from which</p> <p style="text-align: center;">A stainless steel post, 30 ins. long, 2½ ins. diam., set 23 ins. in the ground and over a magnet, for a reference monument, bears N. ¼° E., 75 lks. dist., mkd. S18 MC RM 2009 and an arrow pointing to the cor.</p> <p>Deposit a magnet beneath the iron post.</p> <p>From this point the preliminary SE cor. monument bears West, 6 lks. dist., a limestone, 18 x 9 x 6 ins. above ground, firmly set, mkd. SE COR LC on NW side. The stone is now removed and buried alongside the iron post as a memorial.</p> <hr/> <p style="text-align: center;">EDITOR NOTE.— The field notes show the meanders of Lins Lake to Angle Point No. 7, Lake City Townsite, identical with the special meander cor. on the N. and S. center line of the NW¼ of sec. 18. The record is omitted</p> <hr/> <p>N. 0°05' W., on the W. bdy. of the townsite, identical with the N. and S. center line of the NW¼ of sec. 18.</p> <p>Intervening items of topography are omitted.</p>



Survey of Lake City Townsite  
T. 15 N., R. 20 E., Principal Meridian, Montana

CHAINS 29.50	<p>Angle Point No. 8, Lake City Townsite, identical with the W. 1/16 sec. cor. of secs. 7 and 18, previously described.</p> <hr style="width: 20%; margin: 10px auto;"/> <p>N. 0°05' W., on the W. bdy. of the townsite, identical with the N. and S. center line of the SW¼ of sec. 7.</p>
40.00	<p>Angle Point No. 1, identical with the center W. 1/16 sec. cor. of sec. 7, and place of beginning.</p> <hr style="width: 80%; margin: 10px auto;"/> <p style="text-align: center;">GENERAL DESCRIPTION</p> <p>A considerable variety of land and soil are found in T. 15 N., R. 20 E., of the Principal Meridian, Montana. The general elevation of the township ranges from about 3,500 to 3,800 feet above sea level. The summit of the Little Snowy Mountains, which extend into sections 2 and 3, is about 1,200 feet higher. Most of the northern and northeastern portion of the township is rough and rocky, the central part gently rolling, and the southern part nearly level, is about 1,200 feet lower. The soil of the bottom land along the Yellowstone River is alluvial silt and loam; much of the soil in the center part of the township is a black loam, but the southwestern part is very sandy. There is one small alkali flat which is located along the line between Sections 23 and 24. There is a heavy stand of cottonwood and green ash along the right bank of the river in section 25, a heavy grove of burr oak along the line between Sections 1 and 12, and a good growth of yellow pine, burr oak, and fir timber over most of the mountainous region.</p> <p>The Yellowstone River crosses the southeastern portion of the township; it is a meanderable stream under surveying rules, but there is no navigation on the river, owing principally to the swift current and occasional rapids. A ferry is operated in section 35. There is some navigation on Lins Lake, which is a deep and permanent body of water; only the upper end of the lake extends into this township. Clear Lake is a permanent body of water, meanderable under the Manual regulations. There is an extensive marsh in Sections 16, 21, and 22, which evidently was the bed of a former shallow lake. The marsh and several springs situated along the line between Sections 9 and 16 drain into Lins Lake. Three good springs in Sections 28 and 32, all of considerable flow, are tributary to Clear Lake.</p> <p>The most important developments at the present time are the gold-bearing quartz mineral claims in Sections 4 and 5, and the Montana and Manitoba Railroad, which crosses the northwestern part of the township. A limestone quarry in the NW¼ of the SW¼ of Section 9 may be expanded considerably if there should be a demand for building stone in this vicinity. The proposed Lake City townsite is well chosen and offers many advantages. The applicants for the townsite subdivision are making a bona fide effort to encourage an interest in the area.</p> <p>There are three settlers in Sections 17 and 20 who have small fields in cultivation, under irrigation; three other settlers, one each in Sections 19, 25, and 35, have made</p>



T. 15 N., R. 20 E., Principal Meridian, Montana

CHAINS	<p>their first improvements, and one of them has about 40 acres in cultivation. At present the predominating interest is in stock grazing on the excellent growth of native grasses over most of the township. The township has an excellent water supply. There are several cottages on Ivy Island, in Lins Lake, which are occupied during the summer months.</p> <p>Because of site conditions or a lack of available accessories, superior monuments were constructed at several corner points in the township by setting iron posts or brass tablets in concrete cylinders or cones.</p> <p>The average of a considerable number of readings over all parts of the township gives a value of <math>18^{\circ}10'</math> E. for the mean magnetic declination. There is a range of 20' in local attraction.</p>
--------	---





**UNITED STATES  
DEPARTMENT OF THE INTERIOR  
BUREAU OF LAND MANAGEMENT**

FIELD ASSISTANTS

NAMES	CAPACITY
Eli R. Marker	Surveying Technician
Rebecca N. Link	Surveying Technician
William T. Tally	Survey Aid



### CERTIFICATE OF SURVEY

(I) (~~We~~), Robert Acres, Cadastral Surveyor, HEREBY CERTIFY upon honor that, in pursuance of special instructions bearing the date of the 1st day of April, 2009, (I) (~~We~~) have dependently resurveyed a portion of Rancho San Blas, Mineral Surveys No. 3202, 3205, and 3206, and a portion of the east boundary, and surveyed the subdivisional and meander lines, subdivided sections 7, 18, and 33, and surveyed Lake City Townsite of Township 15 North, Range 20 East, of the Principal Meridian, in the State of Montana, which are represented in the foregoing field notes as having been executed by (me) (~~us~~) and under (my) (~~our~~) direction; and that said survey has been made in strict conformity with the Manual of Surveying Instructions, the special instructions, and in the specific manner described in the foregoing field notes.

July 31, 2009  
Date

Robert Acres  
Cadastral Surveyor

\_\_\_\_\_  
Date

\_\_\_\_\_  
Cadastral Surveyor

### CERTIFICATE OF APPROVAL BUREAU OF LAND MANAGEMENT Billings, Montana

The foregoing field notes of the dependent resurvey of a portion of Rancho San Blas, Mineral Surveys No. 3202, 3205, and 3206, and a portion of the east boundary, and survey of the subdivisional and meander lines, subdivision of sections 7, 18, and 33, and Lake City Townsite of Township 15 North, Range 20 East, Principal Meridian, Montana, executed by Robert Acres, Cadastral Surveyor, having been critically examined and found correct, are hereby approved.

September 15, 2009  
Date

James A. Minnier  
Chief Cadastral Surveyor for Montana

### CERTIFICATE OF TRANSCRIPT

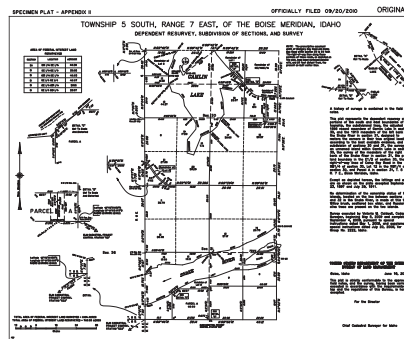
I HEREBY CERTIFY that the foregoing transcript of the field notes of the above described survey, in Township 15 North, Range 20 East, Principal Meridian, Montana, is a true copy of the original field notes.

\_\_\_\_\_  
Date

\_\_\_\_\_  
Chief Cadastral Surveyor for Montana

## Appendix II

# Specimen Field Notes



### DEPENDENT RESURVEY

---

UNITED STATES  
DEPARTMENT OF THE INTERIOR  
BUREAU OF LAND MANAGEMENT

### FIELD NOTES

OF THE  
DEPENDENT RESURVEY OF PORTIONS OF THE  
SOUTH AND WEST BOUNDARIES OF THE TOWNSHIP,  
THE SUBDIVISIONAL LINES,  
THE ADJUSTED 1896 RECORD MEANDERS OF GAMLIN LAKE IN SECTION 30, AND  
THE 1910 MEANDERS OF THE LEFT BANK OF THE SNAKE RIVER IN SECTION 31,  
AND THE  
SUBDIVISION OF SECTIONS 30 AND 31,  
THE SURVEY OF AN UNNAMED ISLAND WITHIN GAMLIN LAKE IN SECTION 30,  
THE SURVEY OF THE MEANDERS OF THE RIGHT BANK OF THE  
SNAKE RIVER IN SECTION 31,  
THE PUBLIC LAND BOUNDARY IN THE E1/2 OF SECTION 30,  
THE RIGHT-OF-WAY LINES OF CAMP BAY ROAD IN THE SW1/4 OF SECTION 30,  
LOT 12 IN THE NW1/4 OF SECTION 30,  
AND PARCEL A IN SECTION 31,  
TOWNSHIP 5 SOUTH, RANGE 7 EAST,  
OF THE BOISE MERIDIAN,  
IN THE STATE OF IDAHO

---

### EXECUTED BY

Victoria M. Caldwell, Cadastral Surveyor

Under special instructions dated and approved May 1, 2009, and supplemental special instructions dated and approved July 20, 2009, which provided for the surveys included under Group Number 2222, Idaho, and assignment instructions dated May 1, 2009.

Survey commenced: May 5, 2009  
Survey completed: September 4, 2009



# INDEX DIAGRAM

T. 5 S., R. 7 E., B.M., IDAHO

Dep. Res. of the Adjusted  
1896 Record Meanders  
of "Gamble" Lake in  
Section 30. . . . . 431-432

Dep. Res. of the 1910 Meanders  
of the Left Bank of the Snake  
River in Section 31. . . . . 432-433

Subdivision of Section 30. . . 433-439

Subdivision of Section 31. . . 439-440

Survey of the 2009 Meanders  
of an Unnamed Island  
within Gamlin Lake in  
Section 30. . . . . 440-441

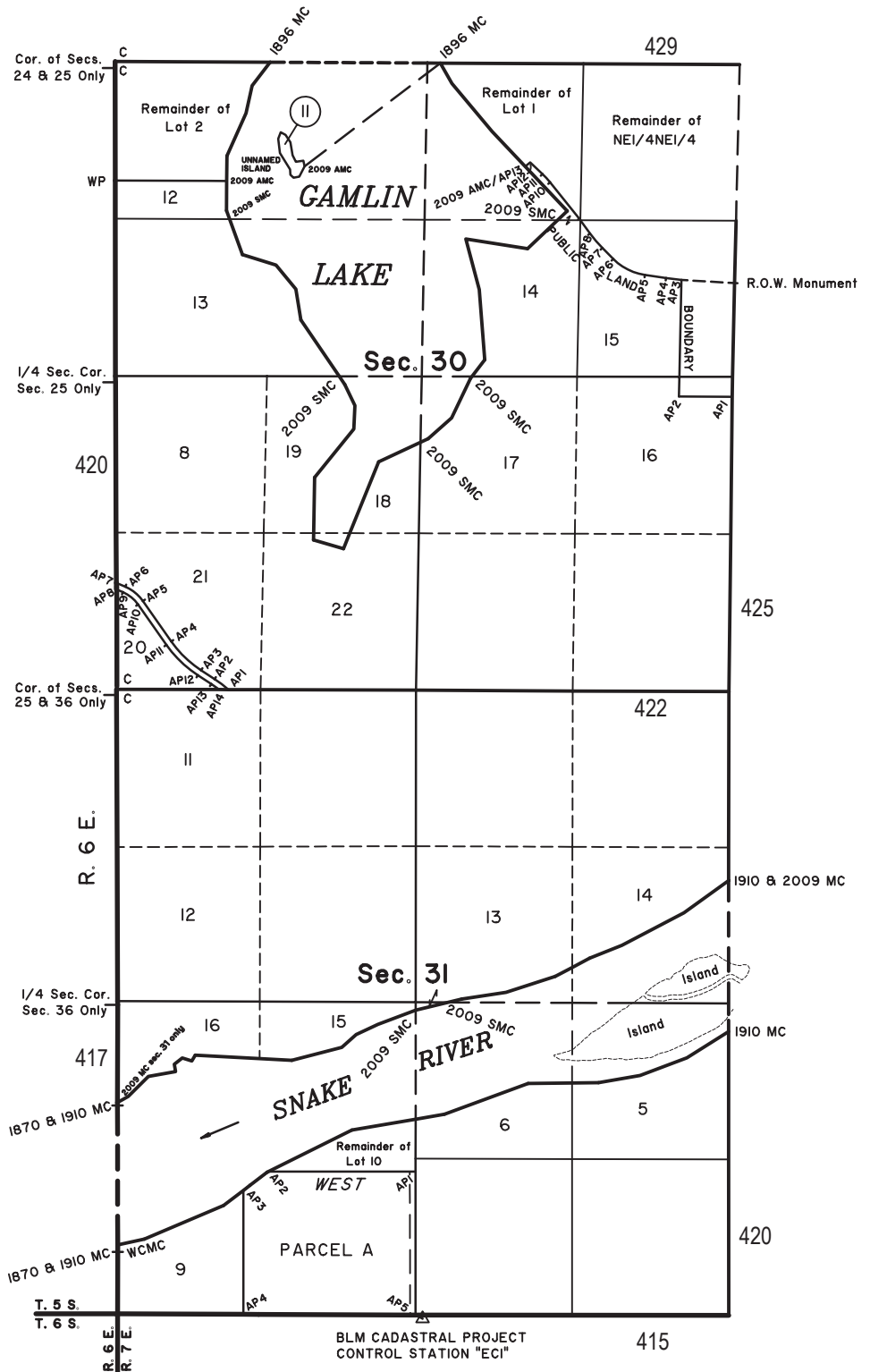
Survey of the 2009 Meanders  
of the Right Bank of  
the Snake River in  
Section 31. . . . . 441-442

Survey of the Public Land  
Boundary in the E1/2  
of Section 30. . . . . 442-443

Survey of the ROW Lines of  
Camp Bay Road in the  
SW1/4 of Section 30. . . . 444-445

Survey of Lot 12 in the  
NW1/4 of Section 30. . . . 445-447

Survey of Parcel A in  
Section 31. . . . . 447-448





## Township 5 South, Range 7 East, Boise Meridian, Idaho

CHAINS	<p>The following field notes are those of the dependent resurvey of portions of the south and west boundaries of the township, the subdivisional lines, the adjusted 1896 record meanders of Gamlin Lake in section 30, and the 1910 meanders of the left bank of the Snake River in section 31, and the subdivision of sections 30 and 31, the survey of an unnamed island within Gamlin Lake in section 30, the survey of the meanders of the right bank of the Snake River in section 31; the public land boundary in the E1/2 of section 30, the right-of-way lines of Camp Bay Road in the SW1/4 of section 30, lot 12 in the NW1/4 of section 30, and Parcel A in section 31, Township 5 South, Range 7 East, Boise Meridian, Idaho.</p> <p>The history of official surveys pertaining to this survey is as follows:</p> <p style="padding-left: 40px;">Theophilus W. Randall, U.S. Deputy Surveyor, surveyed the south boundary in 1870, as shown in the official field notes approved October 20, 1870.</p> <p style="padding-left: 40px;">Theophilus W. Randall, U.S. Deputy Surveyor, surveyed the west boundary (east boundary of Township 5 South, Range 6 East) in 1870, as shown on the official plat of survey approved November 28, 1870.</p> <p style="padding-left: 40px;">Oscar Sonnenkalb, U.S. Deputy Surveyor, surveyed a portion of the subdivisional lines, and the meanders of Gamlin Lake in 1896, as shown on the official plat of survey accepted September 23, 1897.</p> <p style="padding-left: 40px;">Frank D. Maxwell, U.S. Surveyor, resurveyed the south boundary, the west boundary (east boundary of Township 5 South, Range 6 East), and surveyed a portion of the subdivisional lines and meanders of the Snake River in 1910, as shown on the official plat of survey accepted July 29, 1911.</p> <p style="padding-left: 40px;">Dell Cazier, Cadastral Surveyor, resurveyed the west boundary (east boundary of Township 5 South, Range 6 East) in 1967, under Group No. 427, as shown on the official plat of survey accepted November 15, 1972.</p> <p style="padding-left: 40px;">William Y. Kimmel, Cadastral Surveyor, resurveyed a portion of the west boundary (east boundary of Township 5 South, Range 6 East) in 1992, under Group No. 835, as shown on the official plat of survey accepted January 20, 1993.</p> <p>Portions of two islands in the Snake River were identified within section 31 in the course of this survey. Their approximate locations are shown on the official plat. No determination of the status of the two islands located on the line between sections 31 and 32 is made at this time. Willow brush, scattered box elder, and Russian olive trees are present on the two islands.</p> <p>The resurvey was executed in accordance with specifications set forth in the <u>Manual of Surveying Instructions</u> (2009) the Special Instructions, and supplemental Special Instructions for Group No. 2222, Idaho, dated May 1, 2009, and July 20, 2009.</p> <p>The direction of lines were determined by hour-angle observations of the sun, and carried forward by means of fore and backsights, and angles to the right, or by Global</p>
--------	--





## Township 5 South, Range 7 East, Boise Meridian, Idaho

## CHAINS

Positioning System (GPS) Real-Time Kinematic (RTK). The distances were measured on the slope with a Brand Model GTO-68 total-station instrument, or by GPS RTK positioning methods, utilizing Brand Model 4000ESS and Model 4700 dual frequency GPS receivers, conducted in accordance with the Bureau of Land Management "Standard and Guidelines For Cadastral Surveys using Global Positioning System Methods," dated May 9, 2001. The direction of each line is with reference to the true meridian. All bearings are mean bearings. The distances are reported as horizontal measurement at a mean ground elevation of 2,700 feet above sea level. All lines not forming a closure were measured twice to preclude blunder.

Preliminary to the resurvey the lines of the official original survey(s) and resurvey(s) were retraced and search was made for all corners, lines, other calls of the record, and where available, collateral evidence of local surveys and corners. Identified corners were remonumented in their original positions; lost corners were restored and monumented at proportionate positions based on the official record. The retracement data were thoroughly verified and only the true line field notes are given herein. The lines of this survey were posted and blazed in accordance with U.S. Forest Service specifications where indicated by the phrase "posting and blazing true line."

A magnetic memorial was deposited beneath the base of each monument, so indicated. This memorial consists of a magnet, 1 in. long,  $\frac{7}{8}$  in. diam., housed in a cellulose acetate tube,  $2\frac{3}{8}$  ins. long, 1 in. diam., with 1 in. sq. polyethylene end caps, one black and one white.

The geographic coordinates, in NAD 83 (CORS 96) (2002) of the following BLM Cadastral Project Control Stations, as determined in the 1992 resurvey, are:

EC1

Latitude: 42°56'18.685" N. Longitude: 115°40'02.266" W.

EC2

Latitude: 42°55'59.309" N. Longitude: 115°41'17.518" W.

The geographic coordinates, in NAD 83 (CORS 96) (2002) of the following corners, as determined from ties to BLM Cadastral Project Control Stations "EC1" and "EC2", are:

The  $\frac{1}{4}$  sec. cor. of secs. 6 and 31, on the S. bdy. of the Tp.

Latitude: 42°56'18.989" N. Longitude: 115°40'03.073" W.

The cor. of Tps. 5 and 6 S., Rs. 6 and 7 E.

Latitude: 42°56'19.089" N. Longitude: 115°40'36.908" W.

The magnetic declination was not observed.



Dependent Resurvey of a Portion of the South Boundary,  
T. 5 S., R. 7 E., Boise Meridian, Idaho

CHAINS	<p style="text-align: center;">Restoring the 1870 survey executed by Theophilus W. Randall and the 1910 resurvey executed by Frank M. Maxwell</p> <hr style="width: 20%; margin: auto;"/> <p>Beginning at the cor. of secs. 5, 6, 31, and 32, monumented with a basalt stone, 11 x 10 x 4 ins., (Record, 14 x 12 x 6 ins.) broken but firmly set, upright, 8 ins. in the ground, with 5 grooves on the E. and 1 groove on the W. edges.</p> <p>At the corner point</p> <p>Set an aluminum post, 30 ins. long, 2½ ins. diam., 27 ins. in the ground, in a mound of stone, 1 ft. diam., with aluminum cap mkd.</p> <div style="text-align: center; margin: 20px 0;"> <table style="border-collapse: collapse; margin: auto;"> <tr> <td style="padding: 0 5px;">T 5 S</td> <td style="border-left: 1px solid black; padding: 0 5px;">R 7 E</td> </tr> <tr> <td style="padding: 0 5px;">S 31</td> <td style="border-left: 1px solid black; padding: 0 5px;">S 32</td> </tr> <tr> <td colspan="2" style="border-top: 1px solid black; padding: 5px 0 0 0;"></td> </tr> <tr> <td style="padding: 0 5px;">S 6</td> <td style="border-left: 1px solid black; padding: 0 5px;">S 5</td> </tr> <tr> <td colspan="2" style="padding: 5px 0 0 0;"></td> </tr> <tr> <td colspan="2" style="padding: 0 5px;">T 6 S</td> </tr> <tr> <td colspan="2" style="padding: 0 5px;">2009</td> </tr> </table> </div> <p>from which a new bearing object</p> <p style="text-align: center;">A power pole, 12 ins. diam., bears S. 4°46' E., 41.8 lks. dist., power lines bear E. and S.</p> <p>Deposit the mkd. stone and set a steel fence post alongside, and buried a magnet beneath the aluminum post.</p> <p>N. 89°56' W., bet. secs. 6 and 31, posting and blazing true line.</p> <p>20.06 Point for the E. 1/16 sec. cor. of secs. 6 and 31.</p> <p>Set an aluminum post, 30 ins. long, 2½ ins. diam., flush with the surface of the ground, in an embedded mound of stone, 1 ft. diam., with aluminum cap mkd.</p> <div style="text-align: center; margin: 20px 0;"> <table style="border-collapse: collapse; margin: auto;"> <tr> <td style="padding: 0 10px;">E 1/16</td> <td style="border-top: 1px solid black; padding: 0 5px;">S 31</td> </tr> <tr> <td></td> <td style="padding: 0 5px;">S 6</td> </tr> <tr> <td></td> <td style="padding: 0 5px;">2009</td> </tr> </table> </div> <p>Set a steel fence post alongside and buried a magnet beneath the aluminum post.</p>	T 5 S	R 7 E	S 31	S 32			S 6	S 5			T 6 S		2009		E 1/16	S 31		S 6		2009
T 5 S	R 7 E																				
S 31	S 32																				
S 6	S 5																				
T 6 S																					
2009																					
E 1/16	S 31																				
	S 6																				
	2009																				



Dependent Resurvey of a Portion of the South Boundary,  
T. 5 S., R. 7 E., Boise Meridian, Idaho

CHAINS	
	Corner is located on a sandy W. slope.
30.30	From this point, a cor. of fences, bears North, 0.26 chs. dist., fences bear N. 80° E. and S. 89° W.
39.90	Irrigation pipeline, 28 ins. diam., bears N. and S.
40.12	The ¼ sec. cor. of secs. 6 and 31, identical with angle point No. 5, Parcel A, section 31, hereinafter surveyed, monumented with a basalt stone, 26 x 12 x 5 ins., (Record, 24 x 12 x 5 ins.) lying flat, 3 ins. in the ground, mkd. ¼ on the N. face.
	At the corner point
	Set a stainless steel post, 30 ins. long, 2½ ins. diam., 29 ins. in the ground, with brass cap mkd.
	T 5 S   R 7 E S 31 ¼ ————— S 6 T 6 S 2009
	Deposit the mkd. stone alongside and buried a magnet beneath the stainless steel post.
	Corner is located in a barbed wire fence, bears N. 89° E. and W.
	From this cor., BLM Cadastral Project Control Station "EC1," bears S. 62°48'50" E., 1.022 chs. dist., monumented with an aluminum post, 2½ ins. diam., firmly set, flush with the surface of the ground, and in a collar of stone, with aluminum cap mkd. as described in the official field notes of the 1992 resurvey.
	—————
	N. 89°46' W., beginning new measurement, identical with line 5-4 of Parcel A, section 31, hereinafter surveyed, along and near a barbed wire fence.
0.675	South end of the center line of an existing road across Parcel A, section 31, 30 ft. wide, bears N. 0°10' W., identical with angle point No. 3 of an easement in section 6, T. 6 S., R. 7 E., 30 ft. wide, bears S. 0°13' E., said easement is described in the concurrent resurvey in T. 6 S., R. 7 E., under this same Group. Point is located in the center of graveled road, 20 ft. wide, bears S. 0°13' E. and N. 0°10' W.; no permanent monument established.
0.87	Intersect a corner of barbed wire fences bearing E., S., and W., changing to irregularly W.
15.70	From this point, the end of a barbed wire fence, extends irregularly E., bears North, 1.10 chs. dist.



Dependent Resurvey of a Portion of the South Boundary,  
T. 5 S., R. 7 E., Boise Meridian, Idaho

CHAINS	
17.25	Ascend rimrock, bears generally N. and S.; thence over nearly level land on top of Flatiron Butte.
22.03	Point for angle point No. 4, Parcel A, hereinafter surveyed; no permanent monument established.
25.85	Top of rimrock, bears NE and SW; descend.
27.15	From this point, the end of a barbed wire fence, extends W., bears South, 0.11 chs. dist.
38.14	<p>The cor. of Tps. 5 and 6 S., Rs. 6 and 7 E., monumented with a brass disk, 3½ ins. diam., firmly set in concrete, 6 x 6 ins, flush with the surface of the ground, mkd. as described in the official field notes of the 1910 resurvey.</p> <p>Corner is located on top of a boulder, 5 x 4 ft., projecting 4½ ft. above ground, with a brown PVC post, 4 ins. diam., signed IDAHO POWER PROJECT BOUNDARY, located N., 4 ft. dist. of corner.</p> <p>From this corner, BLM Cadastral Project Control Station "EC2," bears S. 56°27'38" W., 54.923 chs. dist., monumented with an iron post, 2½ ins. diam., firmly set, projecting 1 in. above ground, with brass cap mkd. as described in the official field notes of the 1992 resurvey.</p> <hr/> <p style="text-align: center;">Dependent Resurvey of a Portion of the West Boundary, (East Boundary of T. 5 S., R. 6 E.), T. 5 S., R. 7 E., Boise Meridian, Idaho</p> <hr/> <p style="text-align: center;">Restoring the 1870 survey executed by Theophilus W. Randall, the 1910 resurvey executed by Frank M. Maxwell, the 1967 resurvey executed by Dell Cazier, and the 1992 resurvey executed by William Y. Kimmel.</p> <hr/> <p>From the cor. of Tps. 5 and 6 S., Rs. 6 and 7 E., heretofore described.</p> <p>N. 0°07' E., bet. secs. 31 and. 36,.</p> <p>Desc. gradual N. slope, through pasture land, and westerly of a barbed wire fence.</p>
7.920	<p>The point established as the witness cor. to the 1870 and 1910 meander cor. of secs. 31 and 36, on the left bank of Snake River, by William A. Smith, PLS No. 554, in 1965, as shown on Owyhee County Record of Survey Instrument No. 36876, monumented with an iron bar, 1 in. diam., firmly set, 6 ins. below the surface of the ground, and is accepted as a careful and faithful determination of the position of the range line.</p> <p>At the corner point</p>



Dependent Resurvey of a Portion of the West Boundary,  
(East Boundary of T. 5 S., R. 6 E.),  
T. 5 S., R. 7 E., Boise Meridian, Idaho

CHAINS	
	<p>Set a stainless steel post, 30 ins. long, 2½ ins. diam., 28 ins. in the ground, with brass cap mkd.</p> <div style="text-align: center;"> <p style="margin: 0;">WC MC ↑ S 36   S 31 T 5 S R 6 E R 7 E 2009</p> </div> <p>Deposit the iron bar and set a steel fence post alongside, and buried a magnet beneath the stainless steel post.</p> <p>From the witness cor. meander cor., a corner of barbed wire fences, bearing South and N. 50° W., bears S. 20° E., 35 lks. dist.</p> <hr style="width: 20%; margin: 10px auto;"/> <p>N. 0°06' W., beginning new measurement.</p>
0.91	<p>Point for the 1870 and 1910 meander cor. of secs. 31 and 36, on the left bank of Snake River, at proportionate dist., at the present left bank, bears NE and SW; there is no remaining evidence of the original corner; falls on river bank where it is impracticable to establish a permanent monument; over river, course SW.</p>
18.755	<p>Point for the 1870 and 1910 meander cor. of secs. 31 and 36, on the right bank of Snake River, at proportionate dist. by the irregular boundary adjustment method, based on the official record of the 1910 resurvey; falls in river; there is no remaining evidence of the original corner; no permanent monument established.</p> <hr style="width: 20%; margin: 10px auto;"/> <p>N. 0°06' E., beginning new measurement.</p>
0.37	<p>Right bank of Snake River, course S. 60° W.; point for the meander cor. of sec. 31 only.</p> <p>Set a stainless steel post, 30 ins. long, 2½ ins. diam., 28 ins. in the ground, with brass cap mkd.</p> <div style="text-align: center;"> <p style="margin: 0;">T 5 S R 6 E R 7 E   S 31 MC 2009</p> </div> <p>Set a steel fence post alongside and buried a magnet beneath the stainless steel post.</p>





Dependent Resurvey of a Portion of the West Boundary,  
(East Boundary of T. 5 S., R. 6 E.),  
T. 5 S., R. 7 E., Boise Meridian, Idaho

CHAINS	
1.49	<p>From this point, an iron pipe, 2 ins. diam., firmly set, projecting 13 ins. above ground, in a scattered mound of stone, bears East, 0.120 chs. dist., with brass cap mkd. IPCO 50 9L W 36 31 1951 with a brown PVC post, 4 ins. diam., signed IDAHO POWER PROJECT BOUNDARY, set alongside. Through contact with personnel of Idaho Power Company, it was determined that this monument was established using improper procedures, was not properly placed on the range line, and is not utilized in this resurvey.</p>
12.87	<p>The ¼ sec. cor. of sec. 36 only, T. 5 S., R. 6 E., monumented with an iron post, 2½ ins. diam., firmly set, projecting 7 ins. above a mound of stone, 4 ft. base, 1½ ft. high, with brass cap mkd. as described in the official record of the 1967 resurvey, except with the marks R7E present, with a brown PVC post, 4 ins. diam., signed IDAHO POWER PROJECT BOUNDARY, set alongside.</p> <p>From this corner, an iron bar, of no known record, 1½ ins. diam., firmly set, projecting 20 ins. above ground, bears North, 4 lks. dist.</p> <hr style="width: 20%; margin: 10px auto;"/> <p>N. 0°14' W., beginning new measurement.</p>
0.49	<p>The ¼ sec. cor. of sec. 31 only, monumented with an iron post, 2½ ins. diam., firmly set, projecting 12 ins. above ground, in a mound of stone, 3 ft. base, 1 ft. high, with brass cap mkd. as described in the official record of the 1967 resurvey, except with the marks R6E present.</p> <p>From this corner, a railroad tie fence post for a corner of barbed wire fences extending N. and S. 50° E., bears N. 9½° E., 0.65 chs. dist.</p>
39.67	<p>The cor. of secs. 25 and 36, T. 5 S., R. 6 E., monumented with an iron post, 2½ ins. diam., firmly set and leaning, projecting 6 ins. above ground, in a collar of stone, with brass cap mkd. as described in the official record of the 1967 resurvey.</p> <p>At the corner point</p> <p>Reset the iron post, 30 ins. long, flush with the surface of the ground, in an embedded mound of stone, 2½ ft. diam., from which new bearing objects</p> <p style="padding-left: 40px;">A power line brace pole, 8 ins. diam., bears N. 87½° E., 34.5 lks. dist.</p> <p style="padding-left: 40px;">A power pole, 13 ins. diam., bears S. 33° W., 25 lks. dist.</p> <p>Buried a magnet beneath the iron post.</p> <p>Corner is located in a field road, 15 lks. wide, bears N. and S., and W., 5 lks. dist. of a barbed wire fence, bears same.</p> <hr style="width: 20%; margin: 10px auto;"/>



Dependent Resurvey of a Portion of the West Boundary,  
(East Boundary of T. 5 S., R. 6 E.),  
T. 5 S., R. 7 E., Boise Meridian, Idaho

CHAINS	<p>N. 0°57' W., bet. secs. 25 and 31.</p>
0.735	<p>The closing cor. of secs. 30 and 31, monumented with an iron post, 2½ ins. diam., firmly set, projecting 5 ins. above ground, in a collar of stone, with brass cap mkd. as described in the official field notes of the 1910 resurvey.</p> <p>Corner is located E., 6 lks. dist. of the middle of a field road, 15 lks. wide, bears N. and S., and W., 3 lks. dist. of a fence, bears N. and S.</p> <p>From this corner, the amended closing cor. of secs. 30 and 31, bears S. 89°51' E., 0.15 chs. dist., hereinafter described.</p> <hr/> <p>N. 0°05' W., bet. secs. 25 and 30.</p> <p>Asc. over SW slope, through light timber and moderate brush.</p> <hr/> <p>EDITOR NOTE. — Remainder of the west boundary of the township is omitted.</p> <hr/> <p style="text-align: center;">Dependent Resurvey of a Portion of the Subdivisional Lines, T. 5 S., R. 7 E., Boise Meridian, Idaho</p> <hr/> <p style="text-align: center;">Restoring the 1910 survey executed by Frank D. Maxwell</p> <hr/> <p>From the cor. of secs. 5, 6, 31, and 32, on the S. bdy. of the Tp., heretofore described.</p> <p>N. 0°02' W., bet. secs. 31 and 32.</p> <p>Asc. over SE slope through rocky open land.</p>
19.97	<p>Point for the S. 1/16 sec. cor. of secs. 31 and 32.</p> <p>Set a stainless steel post, 30 ins. long, 2½ ins. diam., 26 ins. in the ground, in an embedded mound of stone, 2½ ft. base, to top, with brass cap mkd.</p> <div style="text-align: center; margin: 10px 0;"> <p>S 1/16</p> <p>S 31   S 32</p> <p>2009</p> </div> <p>Set a steel fence post alongside and buried a magnet beneath the stainless steel post.</p>
21.30	<p>Top of rimrock, bears irregularly N. 60° E. and S. 60° W.; descend.</p>

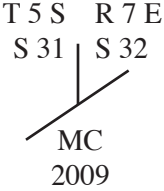


Dependent Resurvey of a Portion of the Subdivisional Lines,  
T. 5 S., R. 7 E., Boise Meridian, Idaho

<p>CHAINS 33.88</p>	<p>An iron post, established by the Idaho Power Company, in 1951, as shown on drawings 20R-9475 and 20-D-16552, 2 ins. diam., loosely set and leaning, projecting 28 ins. above ground, in a scattered mound of stone, with brass cap, 2 ins. diam., mkd. IPCO 31132 NM 64 59 1951, with a brown PVC post, 4 ins. diam., signed IDAHO POWER, alongside, and is accepted as a careful and faithful determination of the section line.</p> <p>At the corner point</p> <p>Set a stainless steel post, 2½ ins. diam., 30 ins. long, 10 ins. in the ground to bedrock, in a mound of stone, 4 ft. base, to top, with brass cap mkd.</p> <div style="text-align: center; margin: 10px 0;"> <p>WP</p> <p>S 31   S 32</p> <p>2009</p> </div> <p>Set a steel fence post alongside deposited a magnet beneath the stainless steel post.</p> <hr style="width: 20%; margin: 10px auto;"/> <p>N. 0°02' E., beginning new measurement.</p>
<p>2.30</p>	<p>Present left bank of Snake River, vertical, 10 ft. high, bears NE and SW; across a secondary channel of Snake River.</p>
<p>2.46</p>	<p>Point for the meander cor. of secs. 31 and 32, on left bank of Snake River, at proportionate dist., falls in a secondary channel of the river; there is no remaining evidence of the original corner; no permanent monument established.</p>
<p>4.60</p>	<p>The SE bank of an island, bears NE and SW. No determination of the status of this island has been made at this time.</p>
<p>6.06</p>	<p>Point for the ¼ sec. cor. of secs. 31 and 32, at proportionate dist.; located within the Snake River in the 1910 survey and not previously monumented. Point falls on an island in the Snake River. No permanent monument established.</p>
<p>8.90</p>	<p>North bank of same island, bears NE turning SE and SW. Thence across a secondary channel of Snake River, 50 lks. wide.</p>
<p>9.40</p>	<p>South bank of an island, bears SE and SW. No determination of the status of this island has been made at this time.</p>
<p>11.40</p>	<p>North bank of same island, bears NW and SE. Thence across the main channel of the Snake River, course SW.</p>
<p>21.78</p>	<p>The meander cor. of secs. 31 and 32, on right bank of Snake River, monumented with a basalt stone, 18 x 15 x 5 ins. (Record, 14 x 12 x 6 ins.), firmly set, 13 ins. in the ground, mkd. MC on the S. face and with 5 grooves on the E. edge, with a mound of stone, 3 ft. base, 1 ft. high, to N.</p>



Dependent Resurvey of a Portion of the Subdivisional Lines,  
T. 5 S., R. 7 E., Boise Meridian, Idaho

<p>CHAINS</p>	<p>At the corner point</p> <p>Set a stainless steel post, 30 ins. long, 2½ ins. diam., 25 ins. in the ground, with brass cap mkd.</p> <div style="text-align: center;"> <p>T 5 S    R 7 E</p> <p>S 31    S 32</p>  <p>MC 2009</p> </div> <p>Deposit the mkd. stone alongside and buried a magnet beneath the stainless steel post.</p> <p>Enlarge the mound of stone to 4 ft. base, 2 ft. high, N. of corner.</p> <p>From this corner, an iron post, established by Acme Water Irrigation Company, in 1933, as a reference monument for irrigation works, 2 ins. diam., firmly set, projecting 15 ins. above ground, bears N. 1°13' E., 0.346 chs. dist., with brass plug mkd. AWIC RM NM75 1933, as shown on Owyhee County Watermaster drawing 20R-9475. Through contact with personnel of Current Water Irrigation District and Owyhee County Surveyor it was determined that this monument had never intended to be placed on the section line, and is not utilized in this resurvey.</p> <hr style="width: 20%; margin: 10px auto;"/> <p>N. 0°06' E., beginning new measurement.</p>
<p>24.21</p>	<p>The cor. of secs. 29, 30, 31, and 32, monumented with a basalt stone, 20 x 9 x 5 ins. (Record, 18 x 10 x 5), firmly set, 15 ins. in the ground, with 1 groove on the S. face and 5 grooves on the E. edge, with evidence of a mound of earth, 5 ft. diam., 5 ins. high, to the W.</p> <p>At the corner point</p> <p>Set a stainless steel post, 30 ins. long, 2½ ins. diam., 28 ins. in the ground, with brass cap mkd.</p> <div style="text-align: center;"> <p>T 5 S    R 7 E</p> <p>S 30    S 29</p> <hr style="width: 50%; margin: 0 auto;"/> <p>S 31    S 32</p> <p>2009</p> </div> <p>Deposit the mkd. stone and set a steel fence post alongside, and buried a magnet beneath the stainless steel post.</p> <hr style="width: 80%; margin: 10px auto;"/> <p>N. 89°50' W., bet. secs. 30 and 31, posting and blazing true line.</p>



Dependent Resurvey of a Portion of the Subdivisional Lines,  
T. 5 S., R. 7 E., Boise Meridian, Idaho

CHAINS	<p>Over rolling land, through moderate timber and undergrowth, generally on S. side of old, poorly maintained barbed-wire fence.</p>
20.01	<p>The E. 1/16 sec. cor. of secs. 30 and 31, established by Lance G. Miller, PLS No. 6107, in 1994, but not depicted as having been monumented, as shown on Owyhee County Record of Survey Instrument No. 452400; monumented with a steel rebar, 5/8 in. diam., firmly set, projecting 3 ins. above ground, with yellow plastic cap, 1 1/4 ins. diam., mkd. MILLER 6107, and is accepted as a careful and faithful establishment of the corner, from which new bearing trees</p> <p style="padding-left: 40px;">A ponderosa pine, 20 ins. diam., bears N. 46° W., 64 1/2 lks. dist., mkd. E 1/16 S30 BT.</p> <p style="padding-left: 40px;">A ponderosa pine, 10 ins. diam., bears N. 3° W., 17 lks. dist., mkd. X BT.</p> <p>Set a steel fence post E., 2 lks. dist. of corner.</p> <p>Corner is located in moderate timber and undergrowth, in old, poorly maintained and down barbed-wire fence, bears irregularly E. and W.</p> <hr style="width: 20%; margin: 10px auto;"/> <p>N. 89°39' W., beginning new measurement.</p> <p>Over rolling land, through moderate timber and undergrowth, generally on N. side of old, poorly maintained barbed wire fence.</p>
20.06	<p>The 1/4 sec. cor. of secs. 30 and 31, monumented with a basalt stone, 20 x 9 x 7 ins. (Record, 18 x 8 x 6), loosely set, 1 in. in the ground, mkd. 1/4 on the N. face.</p> <p>At the corner point</p> <p>Set a stainless steel post, 30 ins. long, 2 1/2 ins. diam., 25 ins. in the ground, with brass cap mkd.</p> <div style="text-align: center; margin: 10px 0;"> <p>T 5 S R 7 E</p> <p>S 30</p> <p>1/4 —————</p> <p>S 31</p> <p>2009</p> </div> <p>Deposit the mkd. stone and set a steel fence post alongside, and buried a magnet beneath the stainless steel post.</p> <p>Corner is located on a gentle SW slope.</p> <hr style="width: 20%; margin: 10px auto;"/>





Dependent Resurvey of a Portion of the Subdivisional Lines,  
T. 5 S., R. 7 E., Boise Meridian, Idaho

CHAINS	<p>N. 89°51' W., beginning new measurement.</p> <p>Continue over rolling land, through moderate timber and undergrowth, on N. side of old, poorly maintained barbed-wire fence.</p>
19.915	<p>Point for W 1/16 sec. cor. of secs. 30 and 31.</p> <p>Set a stainless steel post, 30 ins. long, 2½ ins. diam., 25 ins. in the ground, with brass cap mkd.</p> <div style="text-align: center; margin: 10px 0;"> </div> <p>from which</p> <p style="margin-left: 40px;">A pine, 9 ins. diam., bears N. 18° E., 37 lks. dist., mkd. W1/16 S30 BT.</p> <p style="margin-left: 40px;">A white oak, 14 ins. diam., bears S. 37° E., 74½ lks. dist., mkd. W1/16 S31 BT.</p> <p>Buried a magnet beneath and set a steel fence post W., 2 lks. dist. of corner.</p> <p>Corner is located on level land, on N. side of down barbed-wire fence, bears E. and W.</p>
24.01	<p>Point for angle point No. 1, on the northeasterly right-of-way line of Camp Bay Road, hereinafter surveyed, determined at intersection, 25 ft. dist. from, and at right angle to, the present road center line.</p> <p>Set a brass tablet, ¾ ins. diam., ¾-in. stem, in a drill hole in the top of a basalt rock outcrop, 10 x 4 ft., projecting 3 ft. above ground, with top mkd.</p> <div style="text-align: center; margin: 10px 0;"> </div> <p>from which</p> <p style="margin-left: 40px;">A ponderosa pine, 14 ins. diam., bears N. 79° E., 13 lks. dist., mkd. AP1 S30 BT.</p> <p>Set a steel fence post, NE, 3 lks. dist. of corner.</p>
24.61	<p>Camp Bay Road, graded gravel, 30 lks. wide, in a curve, from S. 50° E. to N. 55° W.</p>



Dependent Resurvey of a Portion of the Subdivisional Lines,  
T. 5 S., R. 7 E., Boise Meridian, Idaho

<p>CHAINS 25.22</p>	<p>Point for angle point No. 14, on the southwesterly right-of-way line of Camp Bay Road, hereinafter surveyed, determined at intersection, 25 ft. dist. from, and at right angle to, the present road center line.</p> <p>Drove a steel rebar, 28 ins. long, <math>\frac{3}{4}</math> in. diam., 26 ins. in the ground, cement an aluminum post, 7 ins. long, <math>2\frac{1}{2}</math> ins. diam., over top, with aluminum cap mkd.</p> <div style="text-align: center; margin: 10px 0;"> <p>T 5 S R 7 E S 30 AP 14 CBR S 31 2009</p> </div> <p>Set a steel fence post, N, 2 lks. dist. of corner.</p>
<p>38.225</p>	<p>The amended closing cor. of secs. 30 and 31, monumented with a basalt stone, 14 x 9 x 4 ins. (Record, 15 x 10 x 7), mkd. CC on the E. face with 1 notch on the S. and 5 notches on the N. edges.</p> <p>At the corner point</p> <p>Set a stainless steel post, 30 ins. long, <math>2\frac{1}{2}</math> ins. diam., 36 ins. in the ground, with brass cap mkd.</p> <div style="text-align: center; margin: 10px 0;"> <p>AM T 5 S R 6 E R 7 E S 25 S 30 S 31 CC 2009</p> </div> <p>Deposit the mkd. stone alongside and buried a magnet beneath the stainless steel post.</p>
<p>38.365</p>	<p>The closing cor. of secs. 30 and 31, on the W. bdy. of the Tp., heretofore described.</p> <hr style="width: 80%; margin: 10px auto;"/> <p style="text-align: center;">Restoring the 1896 survey executed by Oscar Sonnenkalb</p> <hr style="width: 30%; margin: 10px auto;"/> <p>From the cor. of secs. 29, 30, 31, and 32.</p> <p>N. <math>0^{\circ}39'</math> E., bet. secs. 29 and 30.</p> <p>Over rolling land, through moderate timber and undergrowth, on the W. side of barbed-wire fence.</p>



Dependent Resurvey of a Portion of the Subdivisional Lines,  
T. 5 S., R. 7 E., Boise Meridian, Idaho

CHAINS 20.14	<p>The S. 1/16 sec. cor. of secs. 29 and 30, established and recorded by Scott M. Rasor, Idaho PLS No. 6374, in 2002, as shown on Owyhee County Record of Survey Instrument No. 608089; monumented with a steel rebar, 5/8 in. diam., firmly set, projecting 2 ins. above ground, with an aluminum cap, 2 ins. diam., mkd. S 1/16 S29 S30 2002 PLS 6374. This is accepted as a careful and faithful establishment of the corner, from which new bearing trees</p> <p style="padding-left: 40px;">A larch, 19 ins. diam., bears N. 38° E., 27 lks. dist., mkd. S1/16 S29 BT.</p> <p style="padding-left: 40px;">A cedar, 34 ins. diam., bears N. 37° W., 64½ lks. dist., mkd. S1/16 S30 BT.</p> <p>Set a steel fence post W., 2 lks. dist. of corner.</p> <p>Corner is located on level land, in light timber and moderate undergrowth, W., 30 lks. dist. of barbed-wire fence.</p> <p style="text-align: center;">_____</p> <p>N. 0°38' E., beginning new measurement, posting and blazing true line.</p> <p>Continue over level land, through moderate timber and undergrowth, along W. side of barbed-wire fence.</p>
0.56	<p>Old, poorly maintained barbed-wire fence, bears E., 31 lks. dist. to corner of fences extending S. and W.; continue over level land, along W. side of barbed-wire fence.</p>
17.584	<p>Point for angle point No. 1, Public Land Boundary in the E1/2 of sec. 30, determined at record dist. (168.70 ft.) from the ¼ sec. cor. of secs. 29 and 30, heretofore described, based on the land description of the exceptions contained in Owyhee County Warranty Deed Instrument No. 402708, heretofore described.</p> <p>Set a stainless steel post, 30 ins. long, 2½ ins. diam., 27 ins. in the ground, with brass cap mkd.</p> <div style="text-align: center; margin: 20px 0;"> <p>T 5 S    R 7 E</p> <p>   </p> <p>S 30 ——— S 29</p> <p>   </p> <p>  AP 1</p> <p>   </p> <p>  2009</p> </div> <p>Buried a magnet beneath and set a steel fence post, SW, 2 lks. dist. of corner.</p> <p>Corner is located on level land, in light timber and dense brush, E., 4½ lks. dist. of old barbed-wire fence. End of posting and blazing true line.</p>
20.14	<p>The ¼ sec. cor. of secs. 29 and 30, first identified and perpetuated by person(s) unknown; subsequently verified and further perpetuated by Richard C. Tucker, Idaho</p>



Dependent Resurvey of a Portion of the Subdivisional Lines,  
T. 5 S., R. 7 E., Boise Meridian, Idaho

<p>CHAINS</p>	<p>PE No. 1947, as shown on Owyhee County Corner Perpetuation and Filing Record and Record of Survey Instrument No. 210438, both recorded in 1979; and further verified, accepted, and recorded by other local surveyors, and most recently by Scott M. Razor, Idaho PLS No. 6374, in 2002, as shown on Owyhee County Record of Survey Instrument No. 608089; monumented with a galvanized iron pipe, ¾ in. diam., loosely set, projecting 8 ins. above a mound of stone, 3 ft. base, 10 ins. high, and with a brass cap, 2 ins. diam., mkd. T5S R7E 1/4 S29 S30 TUCKER IDAHO NO. 1947, from which the remaining evidence of the original bearing trees</p> <p style="padding-left: 40px;">A sawed and rotted ponderosa pine stump, 36 ins. diam., bears S. 28½° E., 56½ lks. dist., with an old chopped-open blaze. (Record, S. 25° E., 57 lks. dist.)</p> <p>and the 1979 accessory by Tucker</p> <p style="padding-left: 40px;">A Douglas fir, 18 ins. diam., bears N. 60½° E., 51 lks. dist., with healed-blaze.</p> <p>and 2002 accessories by Razor</p> <p style="padding-left: 40px;">A ponderosa pine, 12 ins. diam., bears S. 45° E., 45 lks. dist., mkd. by an aluminum location tag, head high, on side facing corner, and by a nail and shiner, side center.</p> <p style="padding-left: 40px;">A ponderosa pine, 7 ins. diam., bears S. 75½° W., 32½ lks. dist., mkd. by an aluminum location tag, head high, on side facing corner, and by a nail and shiner, side center.</p> <p>This position has been well verified and long recognized by the local surveying community, adjoining landowners, and other interested parties, and is accepted as a careful and faithful perpetuation of the original corner.</p> <p>Corner is located on level land, in light timber and undergrowth, in an old, abandoned and down barbed-wire fence, extends N. and S., and E., 76 lks. dist. of gravel driveway, 15 lks. wide, in a curve, from N. 40° E. to S. 60° W., leading to the "Blue Heron" bed-and-breakfast residence.</p> <hr style="width: 20%; margin: 20px auto;"/> <p>N. 1°19' E., beginning new measurement.</p> <p>Over rolling land, through light timber and moderate undergrowth, generally along old barbed-wire fence line.</p>
<p>12.003</p>	<p>A local property corner, established, but not recorded, by Alan V. Kiebert, Idaho PLS No. 974, in 1984, at intersection with the southwesterly right-of-way line of Glengary Bay Road, at a point 25 ft. dist. from, and at a right angle to, the present road center line, and at record dist. (792.14 ft.) from the ¼ sec. cor. of secs. 29 and 30, based on the land description of the exceptions contained in Owyhee County Warranty Deed</p>



Dependent Resurvey of a Portion of the Subdivisional Lines,  
T. 5 S., R. 7 E., Boise Meridian, Idaho

CHAINS	<p>Instrument No. 402708, heretofore described; monumented with a steel rebar, ½ in. diam., firmly set, projecting 2 ins. above ground, with a yellow plastic cap, mkd. KIEBERT PLS974. This is accepted as a careful and faithful establishment of the point described in Owyhee County Warranty Deed Instrument No. 402708, and is used as a controlling element for a portion of the survey of the Public Land Boundary in the E1/2 of sec. 30, heretofore described.</p> <hr style="width: 20%; margin: 10px auto;"/> <p>N. 1°20' E., beginning new measurement.</p> <p>Continue over open, level land, within the right-of-way of Glengary Bay Road.</p>
0.38	<p>Glengary Bay Road, asphalt surface, 30 lks. wide, bears E. and W., at intersection with graded gravel road, 30 lks. wide, bears irregularly N.; continue over nearly level land, generally along W. edge of gravel road.</p>
7.20	<p>Road curving to N. 35° E; leave road and continue within open, power line clear-cut.</p>
7.985	<p>The N. 1/16 sec. cor. of secs. 29 and 30, established and recorded by Douglas R. Meigs, Idaho PLS No. 5576, in 1994, as shown on Owyhee County Record of Survey Instrument No. 453656; monumented with a steel rebar, 5/8 in. diam., firmly set, projecting 10 ins. above, with a yellow plastic cap, 1¼ ins. diam., mkd. D.R. MEIGS PLS5576. This is accepted as a careful and faithful establishment of the corner.</p> <p>From this cor., the cor. of secs. 19, 20, 29, and 30, bears N. 1°20' E., 19.99 chs. dist., first reported as identified and recorded by Richard C. Tucker, Idaho PE No. 1947, in 1979, as shown on Owyhee County Corner Perpetuation and Filing Record by Philip J. Bloom, Idaho PLS No. 3318 (Tucker Engineering), and Owyhee County Record of Survey Instrument No. 213569; subsequently verified, accepted, and recorded by other local surveyors, and most recently by Lance G. Miller, Idaho PLS No. 6107, in 2000, as shown on Owyhee County Record of Survey Instrument No. 568524; monumented with a galvanized iron pipe, 1 in. diam., firmly set, projecting 19 ins. above ground, with a brass cap, 2 ins. diam, mkd. T5S R7E S19 S20 S29 S30 TUCKER IDAHO NO. 1947, with the original slate stone, 18 x 12 x 4 ins., loosely deposited along the W. side, and when oriented properly, plainly mkd. with 5 grooves on the E. and S. faces, from which the remaining original bearing trees</p> <p style="padding-left: 40px;">A rotted out fir root socket, 32 ins. diam., bears N. 59° E., 27 lks. dist., with no marks. (Record, N. 56½° E., 30 lks.)</p> <p style="padding-left: 40px;">A Douglas fir snag, 22 ins. diam., bears S. 80° W., 111 lks. dist., with a partially chopped open healed-blaze. (Record, 115 lks.)</p> <p style="padding-left: 40px;">A sawed Douglas fir stump, 21 ins. diam., bears N. 46° W., 187 lks. dist., with the lower portion of a healed-blaze.</p> <p>and the 1979 accessories by Tucker</p>





Dependent Resurvey of a Portion of the Subdivisional Lines,  
T. 5 S., R. 7 E., Boise Meridian, Idaho

CHAINS	<p style="text-align: center;">A Douglas fir, 12 ins. diam., bears N. <math>71\frac{1}{2}^{\circ}</math> E., 88 lks. dist., with a healed-blaze.</p> <p style="text-align: center;">A Douglas fir snag, 12 ins. diam., bears S. <math>62\frac{1}{2}^{\circ}</math> E., 112<math>\frac{1}{2}</math> lks. dist., with a healed-blaze.</p> <p style="text-align: center;">A sawed Douglas fir stump, 16 ins. diam., bears N. <math>65\frac{1}{2}^{\circ}</math> W., 45 lks. dist., with the lower portion of a healed-blaze.</p> <p>This position has been well verified and long recognized by the local surveying community, adjoining landowners, and other interested parties, and is accepted as a careful and faithful perpetuation of the original corner.</p> <p>Corner is located on an ENE slope, near the center of an open power line clear-cut, and in an old, abandoned and down barbed-wire fence, bears N. and S,</p> <hr style="width: 50%; margin: 10px auto;"/> <p>From the cor. of secs. 19, 20, 29, and 30.</p> <p>N. <math>89^{\circ}42'</math> W., bet. secs. 19 and 30.</p> <p>Over rolling land, through moderate timber and undergrowth.</p>
19.99	<p>Point for the E. 1/16 sec. cor. of secs. 19 and 30, at proportionate dist. bet. the cor. of secs. 19, 20, 29, and 30, and the 1896 meander cor. of secs. 19 and 30, on the E. shore of Gamlin Lake, hereinafter described, based on the official record of the 1896 survey. Point falls on private land and at request of landowner no permanent monument established.</p>
38.315	<p>The 1896 meander cor. of secs. 19 and 30, on the E. shore of Gamlin Lake, first reestablished and monumented, but not recorded, by Alan V. Kiebert, Idaho PLS No. 974, in 1984, at proportionate dist. bet. the cor. of secs. 19, 20, 29, and 30, and the amended closing cor. of secs. 19 and 30, on the W. bdy. of the Tp., based on the official record of the 1896 survey; subsequently verified and accepted by James R. Weatherly, Idaho PE/LS No. 2896, as shown on Owyhee County Corner Perpetuation and Filing Record and Record of Survey Instrument No. 316993, both recorded in 1986; identified by magnetic location, and presumably monumented with Kiebert's 1984 railroad spike, as described by Weatherly in 1986, at a presently undetermined depth below the asphalt surface of Glengary Bay Road. (The monument was not exposed for practical reasons related to county road maintenance.) There is no remaining evidence of the original corner. This position has been well verified and long recognized by the local surveying community, adjoining landowners, and other interested parties, and is accepted as a careful and faithful reestablishment of the original corner, from which the 1984 accessories by Kiebert, as reported by Weatherly in 1986</p> <p style="text-align: center;">A Douglas fir, 10 ins. diam., bears N. <math>7\frac{1}{4}^{\circ}</math> E., 67<math>\frac{1}{2}</math> lks. dist., with a healed-blaze.</p>



Dependent Resurvey of a Portion of the Subdivisional Lines,  
T. 5 S., R. 7 E., Boise Meridian, Idaho

CHAINS	
	<p style="text-align: center;">A steel rebar, 5/8 in. diam., firmly set, projecting 8 ins. above ground, bears S. 89°42' E., 41.5 lks. dist., with an aluminum cap, 1½ ins. diam., mkd. T5S R7E 1984 21.41/WC S19/S30 MC RLS 974, and an arrow pointing to the corner.</p> <p>Corner is located E., 4½ lks. dist. of the center of Glengary Bay Road, asphalt surface, 35 lks. wide, bears S. 33° E. and N. 33° W., curving to S. 30° E.</p> <hr style="width: 20%; margin: 10px auto;"/> <p>N. 89°42' W., beginning new measurement.</p> <p>Over level land, across Glengary Bay Road.</p>
0.30	<p>Present water's edge, at toe of road fill-slope, on the E. shore of Gamlin Lake; continue across lake.</p>
1.67	<p>Point for the ¼ sec. cor. of secs. 19 and 30, first established and recorded, but not monumented, by Richard C. Tucker, Idaho PE No. 1947, in 1979, at proportionate dist. bet. the cor. of secs. 19, 20, 29, and 30, and the amended closing cor. of secs. 19 and 30, on the W. bdy. of the Tp., based on the official record of the 1896 survey, as shown on Owyhee County Record of Survey Instrument No. 213569; presently determined at proportionate dist. bet. the 1896 meander cors. of secs. 19 and 30, on the E. and W. shores of Gamlin Lake. This point has long been recognized by the local surveying community, adjoining landowners, and other interested parties, and is accepted as a careful and faithful establishment of the position of the original corner. Point falls in Gamlin Lake; no permanent monument established.</p> <hr style="width: 20%; margin: 10px auto;"/> <p>N. 89°42' W., beginning new measurement.</p> <p>Continue across Gamlin Lake.</p>
20.13	<p>True point for the 1896 meander cor. of secs. 19 and 30, on the W. shore of Gamlin Lake, first reestablished and recorded, but not monumented, by Richard C. Tucker, Idaho PE No. 1947, in 1979, at proportionate dist. bet. the cor. of secs. 19, 20, 29, and 30, and the amended closing cor. of secs. 19 and 30, on the W. bdy. of the Tp., based on the official record of the 1896 survey, as shown on Owyhee County Record of Survey Instrument No. 213569; subsequently verified, accepted, and witnessed by James R. Weatherly, Idaho PE/LS No. 2896, as shown on Owyhee County Corner Perpetuation and Filing Record and Record of Survey Instrument No. 316993, both recorded in 1986; presently determined on line with, and at Weatherly's plat-record dist. (410.19 ft.) from, his 1986 witness cor. to the meander cor., hereinafter described. There is no remaining evidence of the original corner. This point has been well verified and long recognized by the local surveying community, adjoining landowners, and other interested parties, and is accepted as a careful and faithful reestablishment of the point for the original corner. Point falls on marshland, in high cattails and standing water, on the W. shore of Gamlin Lake; no permanent monument established.</p>



Dependent Resurvey of a Portion of the Subdivisional Lines,  
T. 5 S., R. 7 E., Boise Meridian, Idaho

CHAINS	<p>From this point, Weatherly's 1986 witness cor. to the 1896 meander cor. of secs. 19 and 30, on the W. shore of Gamlin Lake, bears N. 89°42' W., 6.215 chs. dist.; monumented with a steel rebar, 5/8 in. diam., firmly set, top flush with the surface of the ground, with an aluminum cap, 2 ins. diam., mkd. T5S R7E S19 S30 WCMC 410.25 1986 PE LS 2896, and located on level, wet marshland, in high cattails.</p> <hr style="width: 20%; margin: 10px auto;"/> <p>N. 89°42' W., beginning new measurement.</p> <p>Continue over level, wet marshland, through high cattails.</p>						
19.86	<p>The closing cor. of secs. 19 and 30, on the W. bdy. of the Tp., heretofore described.</p>						
20.00	<p>The amended closing cor. of secs. 19 and 30, monumented with a basalt stone, 14 x 9 x 4 ins. (Record, 15 x 10 x 7), mkd. CC on the E. face with 1 notch on the S. and 5 notches on the N. edges, with evidence of a mound of earth, 5 ft. diam., 5 ins. high, alongside to the W.</p> <p>At the corner point</p> <p>Set a stainless steel post, 30 ins. long, 2½ ins. diam., 36 ins. in the ground, with brass cap mkd.</p> <div style="text-align: center; margin: 10px 0;"> <p>AM T 5 S R 6 E R 7 E</p> <table style="margin: auto; border-collapse: collapse;"> <tr> <td style="border-right: 1px solid black; padding: 0 5px;">S 24</td> <td style="border-right: 1px solid black; padding: 0 5px;">S 19</td> <td style="padding: 0 5px;">CC</td> </tr> <tr> <td style="border-right: 1px solid black; padding: 0 5px;"></td> <td style="border-right: 1px solid black; padding: 0 5px;">S 30</td> <td style="padding: 0 5px;"></td> </tr> </table> <p>2009</p> </div> <p>Deposit the mkd. stone and set a steel fence post alongside, and buried a magnet beneath the stainless steel post.</p> <hr style="width: 80%; margin: 10px auto;"/> <div style="text-align: center; margin: 10px auto;"> <p>Dependent Resurvey of the Adjusted 1896 Record Meanders of Gamlin Lake in Section 30, T. 5 S., R. 7 E., Boise Meridian, Idaho</p> </div> <hr style="width: 80%; margin: 10px auto;"/> <div style="text-align: center; margin: 10px auto;"> <p>Restoring the 1896 survey by Oscar Sonnenkalb</p> </div> <hr style="width: 20%; margin: 10px auto;"/> <p>From the true point for the 1896 meander cor. of secs. 19 and 30, on the W. shore of Gamlin Lake, heretofore described.</p>	S 24	S 19	CC		S 30	
S 24	S 19	CC					
	S 30						



Dependent Resurvey of the Adjusted 1896 Record Meanders of  
Gamlin Lake in Section 30,  
T. 5 S., R. 7 E., Boise Meridian, Idaho

## CHAINS

Thence with the adjusted 1896 record meanders of the shore of Gamlin Lake, in front of private land, in sec. 30.

S. 37° 01' W., 3.795 chs.

S. 11° 59' W., 3.595 chs.

S. 23° 30' W., 5.99 chs.

S. 0° 02' E., 6.99 chs.

At 3.215 chs. on this course, the NE corner of lot 12, hereinafter described, identical with the 2009 auxiliary meander cor. on the W. shore of Gamlin Lake, at a point from which the witness cor. to the 2009 auxiliary meander cor., bears N. 89°49' W., 2.362 chs. dist., hereinafter described.

Continue in front of Federal interest land, lot 12.

S. 20°33' E., 5.995 chs.

At 1.175 chs. on this course, the SE corner of lot 12, hereinafter described, identical with the 2009 special meander cor. on the W. shore of Gamlin Lake, at intersection with the E. and W. center line of the NW1/4 of sec. 30, heretofore described, at a point from which the witness cor. to the 2009 special meander cor., bears N. 89°49' W., 0.505 chs. dist., hereinafter described.

---

EDITOR NOTE.— Remainder of the Dependent Resurvey of the Adjusted 1896 Record Meanders of Gamlin Lake in Section 30 is omitted.

---

Dependent Resurvey of the 1910 Meanders of the  
Left Bank of the Snake River in Section 31,  
T. 5 S., R. 7 E., Boise Meridian, Idaho

---

Restoring the 1910 survey executed by Frank D. Maxwell

---

From the point for the 1910 meander cor. of secs. 31 and 32, for the left bank of the Snake River, heretofore described.

Thence with the adjusted 1910 meanders of the left bank, downstream in sec. 31.

S. 57°50' W., 6.315 chs.

S. 69°19' W., 6.41 chs.

S. 80°18' W., 5.405 chs.

S. 89°17' W., 9.005 chs.

At 3.36 chs. dist. on this course, intersect the N. and S. center line of the SE1/4 of sec. 31; the SE 1/16 sec. cor. of sec. 31 bears S. 0°02' W., 9.74 chs. dist.; no permanent monument established.



Dependent Resurvey of the 1910 Meanders of the  
Left Bank of the Snake River in Section 31,  
T. 5 S., R. 7 E., Boise Meridian, Idaho

CHAINS	<p>At 6 chs. dist on this course the downstream end of an island bears N., 4 chs. dist.</p> <p>S. 69°49' W., 11.42 chs. S. 80°18' W., 12.015 chs.</p> <p>At 3.73 chs. dist. on this course, intersect the N. and S. center line of sec. 31; angle point No. 1, Parcel A, sec. 31 bears S. 0°03' W. 6.715 chs. dist.; no permanent monument established.</p> <p>S. 63°35' W., 12.125 chs. S. 52°36' W., 7.02 chs.</p> <p>At 2.77 chs. dist. on this course, intersect line 2-3, of Parcel A, sec. 31; angle point No. 2, bears N. 53°15' E., 2.94 chs. dist.</p> <p>At 3.84 chs. dist. on this course, intersect line 3-4 of Parcel A, sec. 31; angle point No. 3, Parcel A, bears N. 0°02' W., 0.015 chs. dist.</p> <p>S. 67°04' W., 11.02 chs. S. 77°48' W., 3.505 chs.</p> <p>At end of course, the true point for the 1870 and 1910 meander cor. of secs. 31 and 36, for the left bank of the Snake River, on the E. bdy. of sec. 36, T. 5 S., R. 6 E., heretofore described.</p> <hr/> <p style="text-align: center;">Subdivision of Section 30, T. 5 S., R. 7 E., Boise Meridian, Idaho</p> <hr/> <p>From the ¼ sec. cor. of secs. 30 and 31.</p> <p>N. 1°02' E., on the N. and S. center line of sec. 30.</p> <p>Over rolling land, through moderate timber and undergrowth.</p> <p>20.08 Point for the center south 1/16 sec. cor. of sec. 30, occupied by a pine, 18 ins. diam., mkd. S30 on E. side and CS on W. side, from which</p> <p style="padding-left: 40px;">A stainless steel post, 28 ins. long, 2½ ins. diam., set 23 ins. in the ground, for a reference monument, bears N. 60° 45' E., 125.6 lks. dist., with brass cap mkd. RM C S30 C 2009 and an arrow pointing to the corner.</p> <p style="padding-left: 40px;">A stainless steel post, 28 ins. long, 2½ ins. diam., set 23 ins. in the ground, for a reference monument, bears S. 30° 45' E., 125.6 lks. dist., with brass cap mkd. RM C S30 C 2009 and an arrow pointing to the corner.</p>
--------	--





Subdivision of Section 30,  
T. 5 S., R. 7 E., Boise Meridian, Idaho

CHAINS	
31.09	<p>Point selected for a witness cor. to the 2009 special meander cor. on the S. shore of Gamlin Lake, at intersection with the adjusted 1896 record meanders in sec. 30.</p> <p>Set a stainless steel post, 28 ins. long, 2½ ins. diam., 26 ins. in the ground, and in a collar of stone, with brass cap mkd.</p> <div style="text-align: center;"> <p style="margin: 0;">WC SMC C ↑ S 30 C 2009</p> </div> <p>from which</p> <p style="margin-left: 40px;">A larch, 20 ins. diam., bears S. 68° E., 36 lks. dist., mkd. X BT.</p> <p style="margin-left: 40px;">A fir, 16 ins. diam., bears S. 46° W., 39½ lks. dist., mkd. X BT.</p> <p>Buried a magnet beneath and set a steel fence post, E., 2 lks. dist. of corner.</p> <p>Corner is located on level land, in moderate timber and undergrowth, S., 27 lks. dist. of the present water's edge, on the S. shore of Gamlin Lake, bears N. 70° E. and S. 70° W.</p> <p>Continue within, and across, Gamlin Lake.</p>
31.735	<p>True point for the 2009 special meander cor. on the S. shore of Gamlin Lake, at intersection with the adjusted 1896 record meanders in sec. 30; point falls in Gamlin Lake; no permanent monument established.</p>
40.15	<p>Point for the center ¼ sec. cor. of sec. 30, at intersection with the E. and W. center line, falls in Gamlin Lake; no permanent monument established.</p>
60.215	<p>Point for the center north 1/16 sec. cor. of sec. 30, falls in Gamlin Lake; no permanent monument established.</p>
80.28	<p>The point for the ¼ sec. cor. of secs. 19 and 30.</p> <hr/> <p>From the ¼ sec. cor. of secs. 29 and 30.</p> <p>N. 89°56' W., on the E. and W. center line of sec. 30.</p> <p>Over rolling land, through moderate timber and undergrowth.</p>
6.795	<p>Intersect line 2-3, Public Land Boundary in the E1/2 of sec. 30; angle point No. 2, bears S. 1°12' W., 2.517 chs. dist., hereinafter described; no permanent monument established.</p>



Subdivision of Section 30,  
T. 5 S., R. 7 E., Boise Meridian, Idaho

<p>CHAINS 19.895</p>	<p>Point for the center east 1/16 sec. cor. of sec. 30.</p> <p>Set a stainless steel post, 30 ins. long, 2½ ins. diam., 26 ins. in the ground, and in a collar of stone, with brass cap mkd.</p> <div style="text-align: center; margin: 10px 0;"> <math display="block">\begin{array}{c} \text{E } 1/16 \\ \text{C} \text{ --- } \text{C} \\ \text{S } 30 \\ 2009 \end{array}</math> </div> <p>from which</p> <p style="margin-left: 40px;">A fir, 19 ins. diam., bears S. 68° W., 16 lks. dist., mkd. CE1/16 S30 BT.</p> <p style="margin-left: 40px;">A larch, 20 ins. diam., bears N. 39½° W., 67 lks. dist., mkd. CE1/16 S30 BT.</p> <p>Buried a magnet beneath and set a steel fence post, SW, 2 lks. dist. of corner.</p> <p>Corner is located on nearly level land, in moderate timber and undergrowth, S., 80 lks. dist. of hiking trail, 3 lks. wide, bears E. and N. 80° W.</p>
<p>32.312</p>	<p>Point selected for a witness cor. to the 2009 special meander cor. on the E. shore of Gamlin Lake, at intersection with the adjusted 1896 record meanders in sec. 30.</p> <p>Set a stainless steel post, 30 ins. long, 2½ ins. diam., 24 ins. in the ground, and in a collar of stone, with brass cap mkd.</p> <div style="text-align: center; margin: 10px 0;"> <math display="block">\begin{array}{c} \text{WC} \\ \text{S} \\ \text{SMC } \text{C} \text{ --- } \text{C} \\ 30 \\ 2009 \end{array}</math> </div> <p>from which</p> <p style="margin-left: 40px;">A ponderosa pine, 18 ins. diam., bears N. 75° E., 93 lks. dist., mkd. X BT.</p> <p style="margin-left: 40px;">A larch, 13 ins. diam., bears S. 30° E., 65½ lks. dist., mkd. X BT.</p> <p>Set a steel fence post, E., 2 lks. dist. of corner.</p> <p>Corner is located on level land, in moderate timber and undergrowth, E., 30 lks. dist. of the present water's edge, on the E. shore of Gamlin Lake, bears N. 30° E. and S. 50° W.</p> <p>Continue within, and across, Gamlin Lake.</p>
<p>33.36</p>	<p>True point for the 2009 special meander cor. on the E. shore of Gamlin Lake, at intersection with the adjusted 1896 record meanders in sec. 30; point falls in Gamlin Lake; no permanent monument established.</p>



Subdivision of Section 30,  
T. 5 S., R. 7 E., Boise Meridian, Idaho

CHAINS	
39.79	The center ¼ sec. cor. of sec. 30.
50.15	Present water's edge, on the W. shore of Gamlin Lake, bears S. 30° E. and N. 45° W.
50.34	Point for the 2009 special meander cor. on the W. shore of Gamlin Lake, at intersection with the adjusted 1896 record meanders in sec. 30.  Drove a steel rebar, 24 ins. long, ¾ in. diam., 24 ins. in the ground, cement an aluminum post, 8 ins. long, 2½ ins. diam., over top, with aluminum cap mkd.  <div style="text-align: center;"> <math display="block">C \frac{S}{30} C \text{ SMC}</math> <math display="block">2009</math> </div> <p>from which</p> <p style="margin-left: 40px;">A fir, 23 ins. diam., bears S. 55° E., 44 lks. dist., mkd. SMC S30 BT.</p> <p style="margin-left: 40px;">A Douglas fir, 16 ins. diam., bears S. 35° E., 8½ lks. dist., mkd. SMC S30 BT.</p> <p>Set a steel fence post, S., 2 lks. dist. of corner.</p> <p>Continue over rolling land, through moderate timber and undergrowth.</p>
19.815	Point for the center west 1/16 sec. cor. of sec. 30.  Set a stainless steel post, 30 ins. long, 2½ ins. diam., 26 ins. in the ground, and in a mound of stone, 2 ft. base, to top, with brass cap mkd.  <div style="text-align: center;"> <math display="block">C \frac{W \ 1/16}{S \ 30} C</math> <math display="block">2009</math> </div> <p>from which</p> <p style="margin-left: 40px;">A fir, 9 ins. diam., bears S. 18° E., 16 lks. dist., mkd. CW1/16 S30 BT.</p> <p style="margin-left: 40px;">A granite boulder, 20 x 8 ft., projecting 10 ft. above ground, bears N. 79½° W., 67¼ lks. dist., mkd. BXO near the SW corner, 2 ft. above surface of the ground.</p> <p>Buried a magnet beneath and set a steel fence post, W, 2 lks. dist. of corner.</p>
78.99	The ¼ sec. cor. of sec. 30 only, on the W. bdy. of the Tp.  _____



Subdivision of Section 30,  
T. 5 S., R. 7 E., Boise Meridian, Idaho

CHAINS	<p>From the center east 1/16 sec. cor. of sec. 30.</p> <p>N. 1°11' E., on the N. and S. center line of the NE1/4 of sec. 30.</p> <p>Over rolling land, through moderate timber and undergrowth.</p>
0.80	<p>Hiking trail, 3 lks. wide, bears E. and N. 80° W.</p>
2.70	<p>Leave timber, edge bears N. 50° E. and N. 30° W.; continue over open, grassy meadow and across wet marshland.</p>
18.85	<p>Leave marshland, edge bears S. 40° E. and N. 40° W.; continue through moderate timber and undergrowth.</p>
20.025	<p>Point for the NE 1/16 sec. cor. of sec. 30, at intersection with the E. and W. center line of the NE1/4.</p> <p>Drove a steel rebar, 28 ins. long, 3/4 in. diam., 26 ins. in the ground, cement an aluminum post, 8 ins. long, 2 1/2 ins. diam., over top, with aluminum cap mkd.</p> <p style="text-align: center;">NE 1/16 S 30</p> <p style="text-align: center;">2009</p> <p>from which</p> <p style="padding-left: 40px;">A Douglas fir, 13 ins. diam., bears S. 42° W., 23 1/2 lks. dist., mkd. AP9 S30 BT, identical with the SW bearing tree for angle point No. 9, Public Land Boundary in the E1/2 of sec. 30, hereinafter described.</p> <p style="padding-left: 40px;">A Douglas fir, 13 ins. diam., bears N. 67° W., 61 1/2 lks. dist., mkd. AP9 S30 BT, identical with the NW bearing tree for angle point No. 9, Public Land Boundary in the E1/2 of sec. 30, hereinafter described.</p> <p>Set a steel fence post, SW, 2 lks. dist. of corner.</p> <p>Corner is located on level land, in moderate timber and undergrowth, near the toe of fill-slope, on the SW side of Glengary Bay Road.</p>
20.035	<p>Intersect line 8-9, Public Land Boundary in the E1/2 of sec. 30; angle point No. 9, bears N. 36°06' W., 0.229 chs. dist., hereinafter described; no permanent monument established.</p>
20.64	<p>Glengary Bay Road, asphalt surface, 30 lks. wide, bears S. 37° E. and N. 39° W.</p> <p>Continue across road and asc. over rolling SW slope, through moderate timber and undergrowth.</p>



Subdivision of Section 30,  
T. 5 S., R. 7 E., Boise Meridian, Idaho

CHAINS	
40.055	<p>The E. 1/16 sec. cor. of secs. 19 and 30.</p> <hr/> <p>From the N. 1/16 sec. cor. of secs. 29 and 30.</p> <p>N. 89°49' W., on the E. and W. center line of the NE1/4 of sec. 30.</p> <p>Over rolling SSW slope, through moderate timber and undergrowth.</p>
19.465	<p>Glengary Bay Road, asphalt surface, 30 lks. wide, bears S. 37° E. and N. 39° W.</p>
19.933	<p>Intersect line 8-9, Public Land Boundary in the E1/2 of sec. 30; angle point No. 9, bears N. 36°06' W., 0.241 chs. dist., hereinafter described; no permanent monument established.</p>
19.94	<p>The NE 1/16 sec. cor. of sec. 30.</p>
20.75	<p>Edge of wet marshland, bears S. 40° E. and N. 30° W.; continue through cattails and across standing water.</p>
22.86	<p>Point for a special meander cor. on the E. shore of Gamlin Lake, at intersection with the adjusted 1896 record meanders in sec. 30; point falls in Gamlin Lake; no permanent monument established.</p> <p>Continue within, and across, Gamlin Lake.</p>
39.885	<p>The center north 1/16 sec. cor. of sec. 30.</p> <hr/> <p>From the point for the center north 1/16 sec. cor. of sec. 30.</p> <p>N. 89°49' W., on the E. and W. center line of the NW1/4 of sec. 30.</p> <p>Within, and across, Gamlin Lake.</p>
24.96	<p>True point for the 2009 special meander cor. on the W. shore of Gamlin Lake, at intersection with the adjusted 1896 record meanders in sec. 30, identical with the SE corner of lot 12, hereinafter described; point falls in Gamlin Lake; no permanent monument established.</p>
25.23	<p>Present water's edge, on the W. shore of Gamlin Lake, bears S. 13° E. and N. 24° W.</p>
25.465	<p>Point selected for a witness cor. to the 2009 special meander cor. on the W. shore of Gamlin Lake, at intersection with the adjusted 1896 record meanders in sec. 30.</p> <p>Set a stainless steel post, 30 ins. long, 2½ ins. diam., 24 ins. in the ground, and in a mound of stone, 3 ft. base, to top, with brass cap mkd.</p>





Subdivision of Section 30,  
T. 5 S., R. 7 E., Boise Meridian, Idaho

CHAINS	<div style="text-align: center; margin-bottom: 20px;"> </div> <p>from which</p> <p style="margin-left: 40px;">A larch, 32 ins. diam., bears N. 54° W., 59 lks. dist., mkd. X BT.</p> <p style="margin-left: 40px;">A fir, 29 ins. diam., bears N. 22° W., 139 lks. dist., mkd. X BT.</p> <p>Buried a magnet beneath and set a steel fence post, W., 2 lks. dist. of corner.</p> <p>Continue over rolling land, through moderate timber and undergrowth.</p> <p>39.59 The N. 1/16 sec. cor. of sec. 30 only, on the W. bdy. of the Tp., identical with the SW corner of lot 12, sec. 30, hereinafter described.</p> <hr/> <p style="text-align: center;">Subdivision of Section 31, T. 5 S., R. 7 E., Boise Meridian, Idaho</p> <hr/> <p>From the ¼ sec. cor. of secs. 6 and 31, on the S. bdy. of the Tp., heretofore described, identical with angle point No. 5 Parcel A, sec. 31, hereinafter described.</p> <p>N. 0°03' E., on the N. and S. center line of sec. 31, identical with line 5-1, Parcel A.</p> <p>18.355 Point for angle point No. 1, Parcel A, determined at intersection with a line described as East, 1320 ft.+/- from the previous angle point as described in the legal description in Owyhee County Warranty Deed Instrument No. 85209, hereinafter described in the survey of Parcel A, sec. 31.</p> <p>Set a stainless steel post, 30 ins. long, 2½ ins. diam., 28 ins. in the ground, with brass cap mkd.</p> <div style="text-align: center; margin-bottom: 20px;"> <p>T 5 S R 7 E</p> <p>S 31</p> <p>C</p> <p>2009</p> </div> <p>Buried a magnet beneath and set a steel fence post alongside the stainless steel post.</p>
--------	--




Subdivision of Section 31,  
T. 5 S., R. 7 E., Boise Meridian, Idaho

CHAINS	<p>Corner is located W., 50 lks. of a water pipeline, 28 ins. diam., bears NNE and SSW curving S.</p> <hr/> <p>EDITOR NOTE.— Remainder of the Subdivision of Section 31 is omitted.</p> <hr/> <p style="text-align: center;">Survey of the 2009 Meanders of an Unnamed Island Within Gamlin Lake in Section 30, T. 5 S., R. 7 E., Boise Meridian, Idaho</p> <hr/> <p>Memorandum: An investigation preliminary to this survey determined that the present shore of Gamlin Lake has remained essentially unchanged since the time of the original survey. It was also determined the unnamed island in the northwesterly portion of Gamlin Lake, in section 30, was in existence at the time of statehood, has always been surrounded by water, and is within the adjusted 1896 record meander line. Certain facts relevant to this determination are as follows: (1) The largest trees on this island are a minimum of 140 years old; and (2) Local residents have always known this island to exist, and a very-early local resident kept goats on this island to prevent them from straying. Affidavits attesting to these facts is attached to, and made a part of, this record. In view of the above this island has been classified as unsurveyed public domain land, and is surveyed accordingly.</p> <hr/> <p>From the 1896 meander cor. of secs. 19 and 30, on the E. shore of Gamlin Lake, heretofore described.</p> <p>S. 52°46' W., on a connecting line.</p> <p>Over water, across Gamlin Lake.</p>
21.83	<p>Point for the 2009 auxiliary meander cor. in sec. 30, on the mean high water line and present water's edge, on the SE shore of island, in cattails at a location where it is impracticable to establish a permanent monument; no permanent monument established.</p> <p>From this point, the point selected for a witness cor. to the 2009 auxiliary meander cor. in sec. 30, bears S. 49°20' W., 1.407 chs. dist.</p> <p>Set a stainless steel post, 30 ins. long, 2½ ins. diam., 28 ins. in the ground, with brass cap mkd.</p>



Survey of the 2009 Meanders of an  
 Unnamed Island Within Gamlin Lake in Section 30,  
 T. 5 S., R. 7 E., Boise Meridian, Idaho

CHAINS	<div style="text-align: center; margin-bottom: 20px;">                 WC                  AMC                  T 5 S R 7 E                  S 30                    2009             </div> <p>from which</p> <p style="margin-left: 40px;">A ponderosa pine, 25 ins. diam., bears N. 10½° E., 44 lks. dist., mkd. X BT.</p> <p style="margin-left: 40px;">A ponderosa pine, 27 ins. diam., bears N. 70½° W., 55 lks. dist., mkd. X BT.</p> <p>Buried a magnet beneath the stainless steel post.</p> <p>Corner is located in scattered timber and light undergrowth, on a prominent high spot near the S. end of the island.</p> <p>Thence with the 2009 meanders of the island.</p> <p>N. 14° 10' W., 0.73 chs.                  S. 81° 37' W., 0.975 chs.                  N. 26° 15' W., 0.94 chs.                  N. 10° 32' W., 1.68 chs.                  N. 33° 18' W., 1.13 chs.                  N. 62° 41' W., 0.695 chs.                  S. 20° 45' W., 0.895 chs.                  S. 7° 22' E., 1.84 chs.                  S. 32° 30' E., 2.47 chs.                  S. 3° 18' E., 0.69 chs.                  S. 47° 37' E., 0.55 chs.                  N. 79° 21' E., 0.76 chs.                  N. 26° 29' E., 1.495 chs.</p> <p style="margin-left: 100px;">At end of course, the true point for the 2009 auxiliary meander cor. in sec. 30, on the SE shore of island, and place of beginning.</p> <hr style="border: 0.5px solid black; margin: 20px 0;"/> <p style="text-align: center;">Survey of the 2009 Meanders of the                  Right Bank of the Snake River in Section 31,                  T. 5 S., R. 7 E., Boise Meridian, Idaho</p> <hr style="border: 0.5px solid black; margin: 20px 0;"/> <p>Memorandum: The 2009 meanders of the right bank of the Snake River supersede the 1910 meanders in section 31. The meanders represent the ordinary high water mark.</p> <hr style="border: 0.5px solid black; margin: 20px 0;"/>
--------	--



Survey of the 2009 Meanders of the  
Right Bank of the Snake River in Section 31,  
T. 5 S., R. 7 E., Boise Meridian, Idaho

CHAINS	<p>From the 1910 and 2009 meander cor. of secs. 31 and 32, on the 2009 right bank of the Snake River, heretofore described.</p> <p>Thence with the 2009 meanders of the right bank, in front of Federal interest land, downstream in sec. 31.</p> <p>S. 54° 14' W., 7.05 chs. S. 62° 23' W., 8.97 chs.      At 6 chs. dist. on this course, the downstream end of an island, bears S., 7 chs. dist.</p> <p>S. 68° 10' W., 4.43 chs. S. 62° 09' W., 5.02 chs. S. 72° 03' W., 6.62 chs. S. 81° 25' W., 5.73 chs. S. 76° 33' W., 6.03 chs.      At 1.795 chs. dist. on this course, the point for the 2009 special meander cor. of sec. 31, on the E. and W. center line of sec. 31; no permanent monument established.</p> <p>At end of course, the point for the 2009 special meander cor. of sec. 31, on the N. and S. center line of sec. 31; no permanent monument established.</p> <p>S. 69° 24' W., 5.20 chs. S. 64° 56' W., 3.07 chs. S. 48° 05' W., 2.47 chs. S. 75° 31' W., 6.63 chs. N. 86° 58' W., 12.37 chs. S. 32° 04' W., 0.86 chs. N. 73° 13' W., 1.26 chs. S. 52° 20' W., 1.29 chs. S. 8° 43' E., 0.95 chs. S. 79° 43' W., 3.63 chs. S. 60° 36' W., 1.58 chs.      At end of course, the true point for the 2009 meander cor. of sec. 31 only, for the 2009 right bank of the Snake River, on the W. bdy. of the Tp.</p> <hr/> <p style="text-align: center;">Survey of the Public Land Boundary in the E1/2 of Section 30, T. 5 S., R. 7 E., Boise Meridian, Idaho</p> <hr/> <p>Memorandum: This survey of the public land boundary in the E1/2 of section 30 is based on the land description of the exception contained in Owyhee County Warranty Deed Instrument No. 402708, dated and recorded March 13, 1992, conveying land from J.D. Lumber Inc. to the United States of America. The public land boundary is identical with the southwesterly right-of-way line of Glengary Bay Road and is surveyed parallel with, and 25 feet distance from, the present road center line. The</p>
--------	---



Survey of the Public Land Boundary in the  
 E1/2 of Section 30,  
 T. 5 S., R. 7 E., Boise Meridian, Idaho

CHAINS	<p>exception is 50 feet in width based upon the fact that the prescriptive easement width along this portion of Glengary Bay Road is 50 feet. And further, that Owyhee County, local surveyors, adjoining land owners, and other interested parties, all recognize and agree with the fact that the southwesterly right-of-way line along this portion of the road is 25 feet distant from the present road center line. Because the present road center line has remained unchanged since before the time of the conveyance, the necessary portion of the present road center line was surveyed as a reference line prior to the survey of the southwesterly right-of-way line. This reference line was then used as controlling elements for determining the public land boundary, identical with the road right-of-way location.</p> <hr/> <p>From angle point No. 1, Public Land Boundary, on line bet. secs. 29 and 30, heretofore described.</p> <p>N. 89°36' W., on line 1-2.</p> <p>Over rolling land, through light timber and dense brush.</p> <p>6.818 Point for angle point No. 2, Public Land Boundary, determined latitudinally at deed-record distance (984.68 ft.) from angle point No. 3, hereinafter described, and longitudinally at deed-record distance (450.00 ft.) from angle point No. 1, heretofore described.</p> <p>Set a stainless steel post, 30 ins. long, 2½ ins. diam., 26 ins. in the ground, and in a mound of stone, 2 ft. base, to top, with brass cap mkd.</p> <div style="text-align: center; margin: 10px 0;"> <p>T 5 S   R 7 E</p> <p>    S 30</p> <p>     </p> <p>    └──</p> <p>    AP 2</p> <p>    2009</p> </div> <p>from which</p> <p style="padding-left: 40px;">A Douglas fir, 14 ins. diam., bears S. 57° W., 81½ lks. dist., mkd. AP2 S30 BT.</p> <p>Buried a magnet beneath and set a steel fence post, SW, 2 lks. dist. of corner.</p> <p>Corner is located on level land, in dense small timber and undergrowth.</p> <hr/> <p>EDITOR NOTE.— Remainder of the Public Land Boundary is omitted.</p> <hr/>
--------	---







Survey of the Right-of-Way Lines of  
Camp Bay Road in the SW1/4 of Section 30,  
T. 5 S. R. 7 E., Boise Meridian, Idaho

CHAINS	<p style="text-align: center;">A Douglas fir, 19 ins. diam., bears N. 78° E., 29 lks. dist., mkd. AP2 S30 BT.</p> <p style="text-align: center;">A Douglas fir, 17 ins. diam., bears N. 34° W., 24½ lks. dist., mkd. AP2 S30 BT.</p> <p>Set a steel fence post, N., 4½ lks. dist. of corner.</p> <hr style="width: 20%; margin: 10px auto;"/> <p>N. 56°53' W., on line 2-3, on the northeasterly right-of-way line of Camp Bay Road, parallel with, and 25 ft. dist. from, the present road center line.</p> <hr style="width: 80%; margin: 10px auto;"/> <p>EDITOR NOTE.— Remainder of the Survey of the Right-of-Way Lines of Camp Bay Road is omitted.</p> <hr style="width: 80%; margin: 10px auto;"/> <p style="text-align: center;">Survey of Lot 12 in the NW1/4 of Section 30, T. 5 S., R. 7 E., Boise Meridian, Idaho</p> <hr style="width: 80%; margin: 10px auto;"/> <p>Memorandum: This survey of lot 12 in the NW1/4 of section 30 is based on the land description contained in Owyhee County Warranty Deed Instruction No. 622165, dated and recorded April 9, 2003, conveying land from The Nature Conservancy to the United States of America. Lot 12 is riparian to Gamlin Lake.</p> <hr style="width: 80%; margin: 10px auto;"/> <p>From the NW corner of lot 12, identical with the witness point on the W. bdy. of sec. 30, heretofore described.</p> <p>S. 89°49' E., on the N. boundary of lot 12, parallel with, and 322 ft. dist. from, the E. and W. center line of the NW1/4 of sec. 30, heretofore described.</p> <p>Over nearly level land, through moderate timber and undergrowth.</p>
11.908	<p>Point selected for a witness cor. to the 2009 auxiliary meander cor. on the W. shore of Gamlin Lake.</p> <p>Set a stainless steel post, 30 ins. long, 2½ ins. diam., 28 ins. in the ground, with brass cap mkd.</p> <div style="text-align: center; margin: 20px 0;"> <p>WC</p> <p>T 5 S R 7 E</p> <p>S</p> <p>→ AMC</p> <p>30</p> <p>2009</p> </div> <p>from which</p>



Survey of Lot 12 in the NW1/4 of Section 30,  
T. 5 S., R. 7 E., Boise Meridian, Idaho

<p>CHAINS</p>	<p>A Douglas fir, 8 ins. diam., bears S. 12° W., 36 lks. dist., mkd. X BT.</p> <p>A Douglas fir, 12 ins. diam., bears S. 87° W., 46½ lks. dist., mkd. WC AMC S30 BT.</p> <p>Buried a magnet beneath and set a steel fence post, S., 2 lks. dist. of corner.</p> <p>Corner is located on level land, in grassy meadow, near E. edge of moderate timber and undergrowth, W., 31 lks. dist. of present water's edge, on the W. shore of Gamlin Lake, bears N. 8° E. and S. 35° E.</p> <p>Continue within Gamlin Lake, through cattails, and across water.</p> <p>14.27 The NE corner of lot 12, identical with the true point to the 2009 auxiliary meander cor. on the W. shore of Gamlin Lake, at intersection with the adjusted 1896 record meanders in sec. 30; point falls in Gamlin Lake; no permanent monument established.</p> <hr style="width: 20%; margin: 10px auto;"/> <p>S. 0°02' E., beginning new measurement, along the meanders of lot 12.</p> <p>In front of Federal interest land, lot 12, identical with the adjusted 1896 record meanders of the shore of Gamlin Lake, heretofore described.</p> <p>3.775 An angle point on the adjusted 1896 record meanders of the shore of Gamlin Lake, heretofore described; no permanent monument established.</p> <hr style="width: 20%; margin: 10px auto;"/> <p>S. 20°33' E., beginning new measurement, along the meanders of lot 12.</p> <p>In front of Federal interest land, lot 12, identical with the adjusted 1896 record meanders of the shore of Gamlin Lake, heretofore described.</p> <p>1.175 The SE corner of lot 12, identical with the true point for the 2009 special meander cor. on the W. shore of Gamlin Lake, at intersection with the E. and W. center line of the NW1/4, heretofore described; point falls in Gamlin Lake; no permanent monument established.</p> <hr style="width: 20%; margin: 10px auto;"/> <p>N. 89° 49' W., beginning new measurement.</p> <p>On the S. boundary of lot 12, identical with the E. and W. center line of the NW1/4, heretofore described.</p> <p>0.505 The witness cor. to the 2009 special meander cor. on the W. shore of Gamlin Lake, heretofore described.</p> <p>14.63 The SW corner of lot 12, identical with the N. 1/16 sec. cor. of sec. 30 only, on the W. bdy. of the Tp., heretofore described.</p> <hr style="width: 20%; margin: 10px auto;"/>
---------------	--



Survey of Lot 12 in the NW1/4 of Section 30,  
T. 5 S., R. 7 E., Boise Meridian, Idaho

CHAINS	<p>N. 0°05' W., beginning new measurement.</p> <p>On the W. boundary of lot 12, identical with the W. bdy. of the Tp., heretofore described.</p>
4.88	<p>The NW corner of lot 12, identical with a witness point on the W. bdy. of the Tp., heretofore described.</p> <hr style="border: 0.5px solid black; margin: 10px 0;"/> <p style="text-align: center;">Survey of Parcel A in Section 31, T. 5 S., R. 7 E., Boise Meridian, Idaho</p> <hr style="border: 0.5px solid black; margin: 10px 0;"/> <p>Memorandum: Parcel A is that portion of lots 9 and 10, section 31, described as the exception in Owyhee County Warranty Deed Instrument No. 85209, dated September 27, 1951, and recorded July 3, 1952 in Book 43 of Deeds, Page 147, conveying land from Tom L. and Elenor Jones to Idaho Power Company. Parcel A is shown on sheet 16 of 17 of Idaho Power Company drawing 20-D-165522, dated 1-25-54, titled C.J. Strike H.E. DEV. PROJECT BOUNDARIES. Drawing 20-D-165522 superseded sheet 87 of drawing 20R-9475, dated 6-30-52, and titled the same.</p> <hr style="border: 0.5px solid black; margin: 10px 0;"/> <p>From angle point No. 1, Parcel A, on the N. and S. center line of sec. 31, heretofore described.</p> <p>West, on line 1-2, Parcel A, on the bearing described in the legal description contained in Owyhee County Warranty Deed Instrument No. 85209.</p>
0.755	<p>North end of the center line of an existing road across Parcel A, 30 ft. wide, bears S. 0°10' E. Point is located in the center of a graveled road, 20 ft. wide, bears North and S. 0°10' E.; no permanent monument established.</p>
18.86	<p>Point for angle point No. 2, Parcel A, determined at the record distance, according to the legal description contained in Owyhee County Warranty Deed Instrument No. 85209.</p> <p>Set a stainless steel post, 30 ins. long, 2½ ins. diam., 27 ins. in the ground, with brass cap mkd.</p> <div style="text-align: center; margin: 10px 0;"> <p>T 5 S   R 7 E</p> <p>      S 31</p> <p>      /</p> <p>      AP 2</p> <p>      PAR A</p> <p>      2009</p> </div> <p>Buried a magnet beneath and set a steel fence post alongside the stainless steel post.</p> <hr style="border: 0.5px solid black; margin: 10px 0;"/>



Survey of Parcel A in Section 31,  
T. 5 S., R. 7 E., Boise Meridian, Idaho

CHAINS	<p>S. 53°15' W., on line 2-3, Parcel A, on the bearing described in the legal description contained in Owyhee County Warranty Deed Instrument No. 85209.</p>
2.94	<p>Intersect the adjusted 1910 meanders of the left bank of the Snake River, bears N. 52°36' E. and S. 52°36' W. From this point, the present left bank bears northwesterly, 1.10 chs. dist., bank bears NE and SW.</p>
4.00	<p>Point for angle point No. 3, Parcel A; no permanent monument established.</p> <p>S. 0°02' E., on line 3-4, Parcel A sec. 31.</p>
0.015	<p>Intersect the adjusted 1910 meanders of the left bank of the Snake River, bears N. 52°36' E. and S. 52°36' W. From this point, the present left bank bears northwesterly, 1.10 chs. dist., bank bears NE and SW.</p>
15.875	<p>The point for angle point No. 4, Parcel A, heretofore described.</p>
<p><b>GENERAL DESCRIPTION</b></p> <p>The area contained in this survey is located in broken land in Elmore and Owyhee Counties, approximately 8 miles northeast of Bruneau, Idaho. The land is drained by draws and canyons which drain into the Snake River, which flows southwesterly through the area of the survey. Elevations range from about 2,100 feet above sea level along the Snake River to about 2800 feet above sea level on uplands on the north and south sides of the river.</p> <p>Graveled and dirt roads extending northerly from State Highway No. 78 and southerly from Goldsmith Road provide access to the area. There are several pumping stations along the Snake River which provide irrigation water to farmland north, south, and northwest of the area surveyed. The area of the survey along the Snake River is used for the grazing of cattle. In section 30 the soils in the area consist mainly of a rocky loam, and no evidence of any mineral activity was noted. Almost all of the forested areas have been logged at one point in time, and there are several home-site tracts adjacent to, or within, the survey area. At the present time, the area appears to be mostly valuable for scenic and recreational purposes, and the Bureau of Land Management Gamlin Lake Recreation Site is located on the southeasterly side of the lake, in the NE1/4 of section 30. Access to this site is provided by Glengary Bay Road.</p> <p>In section 31 the vegetation is sagebrush, greasewood and grass. Islands in the Snake River on the east and west side of the area surveyed are covered with willow brush and scattered box elder and Russian olive trees. Most of the survey area in section 30 is forest land consisting of ponderosa, white, and lodgepole pine, Douglas and grand fir, cedar, and larch timber. Cottonwood, alder, and willow is present throughout the area, with open, grassy meadows and wet marshland in those areas adjacent to Gamlin Lake, which is located in the northerly portion of section 30.</p>	





**CERTIFICATE OF SURVEY**

I, Victoria M. Caldwell, Cadastral Surveyor, HEREBY CERTIFY upon honor, that in pursuance of special instructions bearing the date of the 1st day of May, 2009, and the supplemental special instructions bearing the date of the 20<sup>th</sup> day of July 2009, I have dependently resurveyed a portion of the south and west boundaries of the township, the subdivisional lines, the adjusted 1896 record meanders of Gamlin Lake in Section 30, and the 1910 meanders of the left bank of the Snake River in section 31, and the subdivision of sections 30 and 31, the survey of an unnamed island within Gamlin Lake in section 30, the survey of the meanders of the right bank of the Snake River in section 31; the public land boundary in the E1/2 of section 30, the right-of-way lines of Camp Bay Road in the SW1/4 of section 30, lot 12 in the NW1/4 of section 30, and Parcel A in section 31, Township 5 South, Range 7 East, Boise Meridian, in the State of Idaho, which are represented in the foregoing field notes as having been executed by me and under my direction; and that said survey has been made in strict conformity with the special instructions, the Manual of Surveying Instructions, and in the specific manner described in the foregoing field notes.

May 19, 2010

Date

*Victoria M. Caldwell*

Cadastral Surveyor

**CERTIFICATE OF APPROVAL**

BUREAU OF LAND MANAGEMENT

Boise, Idaho

The foregoing field notes of the dependent resurvey of a portion of the south and west boundaries of the township, the subdivisional lines, the adjusted 1896 record meanders of Gamlin Lake in Section 30, and the 1910 meanders of the left bank of the Snake River in section 31, and the subdivision of sections 30 and 31, the survey of an unnamed island within Gamlin Lake in section 30, the survey of the meanders of the right bank of the Snake River in section 31; the public land boundary in the E1/2 of section 30, the right-of-way lines of Camp Bay Road in the SW1/4 of section 30, lot 12 in the NW1/4 of section 30, and Parcel A in section 31, Township 5 South, Range 7 East, Boise Meridian, Idaho, executed by Victoria M. Caldwell, Cadastral Surveyor, having been critically examined and found correct, are hereby approved.

June 18, 2010

Date

*Marian E. Rynock*

Chief Cadastral Surveyor for Idaho

**CERTIFICATE OF TRANSCRIPT**

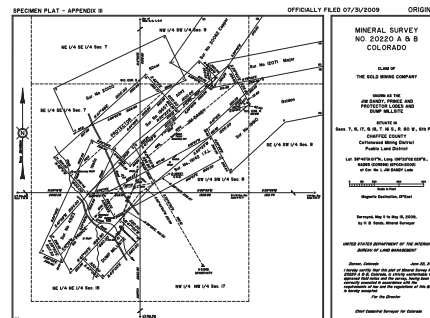
I CERTIFY That the foregoing transcript of the field notes of the above described surveys in Township 5 South, Range 7 East, Boise Meridian, Idaho, is a true copy of the original field notes.

\_\_\_\_\_  
Date

\_\_\_\_\_  
Chief Cadastral Surveyor for Idaho

# Appendix III

# Specimen Field Notes



## MINERAL SURVEY

UNITED STATES  
DEPARTMENT OF THE INTERIOR  
BUREAU OF LAND MANAGEMENT

MINERAL SURVEY NO. 20220 A and B

COLORADO

FIELD NOTES

OF THE

SURVEY OF THE MINING CLAIM OF THE GOLD MINING COMPANY

KNOWN AS THE JIM DANDY, PRINCE, AND PROTECTOR LODES AND DUMP MILLSITE

COTTONWOOD MINING DISTRICT, CHAFFEE COUNTY

SECTIONS 7, 8, 17, AND 18, TOWNSHIP 16 SOUTH, RANGE 80 WEST,  
OF THE SIXTH PRINCIPAL MERIDIAN,  
IN THE STATE OF COLORADO

Surveyed by H.B. SANDS, Mineral Surveyor, under order dated April 9, 2009

Survey Commenced May 11, 2009; Completed May 15, 2009

Address of claimant's agent,  
John Jones, 561 Foster Building, Denver, Colorado 81401

Name of Claim	Dates of Locations and Amended Locations	Recorded With County	Recorded With BLM	BLM Mining Claim Serial Number
Jim Dandy	7/26/1932	9/29/1980	10/09/1980	CMC 164161
Prince	8/31/1930	9/29/1980	10/09/1980	CMC 164160
	Amended 8/10/1971	9/23/2004	9/29/2004	
Protector	8/31/1930	9/29/1931	10/09/1931	CMC 164159
	Amended 6/16/1971	9/12/1971	10/07/1971	
Dump Millsite	8/10/1971	9/29/1980	10/09/1980	CMC 164162



Mineral Survey No. 20220 A and B  
T. 16 S., R. 80 W., Sixth Principal Meridian, Colorado

FEET

This survey was made with one Name Brand Navigation, Model Number 1234 ssi, Global Positioning System (GPS) base receiver, serial number 3543A11961, one Name Brand Navigation, Model Number 5678 GPS rover receiver, serial number 0430103786, and one Name Brand total station, Model ABC-901, serial number 0368756, to measure angles and distances. The instruments were in good condition at the time of the survey, all adjustments were in good order, and compared with a standard at the time of beginning the survey and found to be correct.

The basis of bearing for this survey was determined with reference to the true meridian from Cor. No. 1 of the Jim Dandy lode, at Latitude 38° 45' 01.017" N., and Longitude 106° 20' 02.029" W., NAD 83 (CORS96) (EPOCH:2002), to the cor. of secs. 7, 8, 17, and 18 as calculated from the GPS observations of these monuments. The resultant mean bearing and ground distance is S. 55° 40' 00" W., 212.50 ft. dist. All bearings in this record refer to the true meridian and are mean bearings.

Lines and connections of this survey were run using GPS real time kinematic surveying system or by direct methods where the lines are accessible. The inaccessible lines were run by traverse methods. The distances are reported as horizontal measurement at a mean ground elevation of 5,000 feet above sea level, in U.S. Survey Foot.

The magnetic declination observed at some corners of the survey gave a uniform value of 13° E.

---

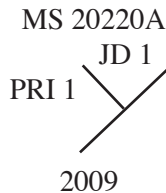
**Mineral Survey No. 20220 A**

---

**JIM DANDY LODE**

Beginning at Cor. No. 1 of the Jim Dandy lode, identical with Cor. No. 1 of the Prince lode of this survey.

Set a stainless steel post, 28 ins. long, 2½ ins. diam., 23 ins. in the ground, with brass cap mkd.



from which

The cor. of secs. 7, 8, 17, and 18, bears S. 55° 40' 00" W., 212.50 ft. dist., hereinafter described.

U.S. Mineral Monument SPORPHYRY bears S. 30° 15' 30" E., 1,165.81 ft. dist., hereinafter described.



Mineral Survey No. 20220 A  
 T. 16 S., R. 80 W., Sixth Principal Meridian, Colorado

FEET	<p>Cor. No. 3, M.S. No. 18837 C.O.D. lode, bears N. 58° 45' E., 208.47 ft. dist., hereinafter described.</p> <p>A yellow pine, 14 ins. diam., bears N. 10° 00' E., 38.3 ft. dist. to face, mkd. JD 1 20220A XBT.</p> <p>A distant peak, known as Barren Mt., bears N. 55° 57' W.</p> <p style="text-align: center;">Thence N. 28° 50' W.</p>
170.28	<p>Intersect line 3-4, M.S. No. 19142 I.X.L. lode, at a point from which Cor. No. 3 bears N. 61° 27' E., 871.43 ft. dist. and Cor. No. 4 bears S. 61° 27' W., 628.57 ft. dist., both hereinafter described.</p>
301.30	<p>Lode line; discovery point bears N. 50° 23' E., 496 ft. dist., hereinafter described.</p>
350.97	<p>Intersect line bet. secs. 7 and 8, at a point from which the cor. of secs. 5, 6, 7, and 8 bears N. 0° 50' E., 4,886.17 ft. dist. and the cor. of secs. 7, 8, 17, and 18 bears S. 0° 50' W., 427.35 ft. dist., both hereinafter described.</p>
370.28	<p>Intersect line 4-1, M.S. No. 19557 Alley lode, at a point from which Cor. No. 4 bears N. 44° 30' E., 1,332.42 ft. dist. and Cor. No. 1 bears S. 44° 30' W., 167.58 ft. dist., both hereinafter described.</p>
456.67	<p>Intersect line 4-1, Protector lode of this survey, at a point from which Cor. No. 4 bears N. 47° 49' E., 696.94 ft. dist. and Cor. No. 1 bears S. 47° 49' W., 803.06 ft. dist., both hereinafter described.</p>
535.90	<p>Cor. No. 2, identical with Cor. No. 2 of the Prince lode of this survey.</p> <p>Set a stainless steel post, 28 ins. long, 2½ ins. diam., 24 ins. in the ground, and in a mound of stone, 3 ft. base to top, with brass cap mkd.</p> <div style="text-align: center; margin: 10px 0;"> <p>MS 20220A</p> </div> <p>from which</p> <p style="text-align: center;">A granite rock in place, 46 x 34 ins., 26 ins. above ground, bears S. 24° 00' E., 10.5 ft. dist., mkd. XBO JD 2 20220A.</p> <p style="text-align: center;">Thence N. 50° 23' E.</p>
120.28	<p>Intersect line bet. secs. 7 and 8, at a point from which the cor. of secs. 5, 6, 7, and 8 bears N. 0° 50' E., 4,647.44 ft. dist. and the cor. of secs. 7, 8, 17, and 18 bears S. 0° 50' W., 666.08 ft. dist., both hereinafter described.</p>





Mineral Survey No. 20220 A  
T. 16 S., R. 80 W., Sixth Principal Meridian, Colorado

FEET	
679.32	Intersect line 3-4, Protector lode of this survey, at a point from which Cor. No. 4 bears S. 42° 11' E., 46.70 ft. dist. and Cor. No. 3 bears N. 42° 11' W., 553.30 ft. dist., both hereinafter described.
1,150.19	Intersect line 4-1, M.S. No. 20062 Copper lode, at a point from which Cor. No. 4, identical with Cor. No. 2, M.S. No. 12071 Major lode, bears S. 59° 25' E., 94.50 ft. dist. and Cor. No. 1 bears N. 59° 25' W., 505.50 ft. dist., both hereinafter described.
1,230.73	Intersect line 1-2, M.S. No. 12071 Major lode, at a point from which Cor. No. 2, identical with Cor. No. 4, M.S. No. 20062 Copper lode, bears S. 11° 00' E., 101.30 ft. dist. and point for Cor. No. 1 bears N. 11° 00' W., 198.70 ft. dist., both hereinafter described.
1,291.67	Intersect line 3-4, M.S. No. 19557 Alley lode, at a point from which Cor. No. 4 bears S. 45° 30' E., 26.31 ft. dist. and point for Cor. No. 3 bears N. 45° 30' W., 273.69 ft. dist., both hereinafter described.
1,500.00	<p>Cor. No. 3, on line 3-4, M.S. No. 20062 Copper lode.</p> <p>Falls on granite bedrock outcrop, even with the general surface of the ground, mkd. X JD 3 20220A; from which</p> <p style="padding-left: 40px;">Cor. No. 3, M.S. No. 20062 Copper lode, bears N. 34° 45' E., 1,270.00 ft. dist., hereinafter described.</p> <p style="padding-left: 40px;">Cor. No. 4, M.S. No. 20062 Copper lode, bears S. 34° 45' W., 330.00 ft. dist., identical with Cor. No. 2, M.S. No. 12071 Major lode, both hereinafter described.</p> <p style="padding-left: 40px;">A silver spruce, 16 ins. diam., bears N. 40° 00' E., 47.5 ft. dist. to face, mkd. JD 3 20220A XBT.</p> <p style="text-align: center;">Thence S. 28° 50' E.</p>
234.60	Lode line; discovery point bears S. 50° 23' W., 1,004 ft. dist., hereinafter described.
241.90	Intersect line 2-3, M.S. No. 12071 Major lode, at a point from which Cor. No. 2, M.S. No. 19910 Golden lode bears N. 79° 00' E., 299.46 ft. dist. and Cor. No. 2, identical with Cor. No. 4, M.S. No. 20062 Copper lode, bears S. 79° 00' W., 310.46 ft. dist., both hereinafter described.
404.50	Intersect line 1-2, M.S. No. 19910 Golden lode, claimant herein, at a point from which Cor. No. 2 bears N. 47° 12' E., 280.00 ft. dist. and Cor. No. 1 bears S. 47° 12' W., 620.00 ft. dist., both hereinafter described; identical with a Cor. of Tract A, hereinafter surveyed.
535.90	Cor. No. 4; identical with a Cor. of Tract A, hereinafter described.

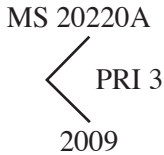


Mineral Survey No. 20220 A  
 T. 16 S., R. 80 W., Sixth Principal Meridian, Colorado

FEET	<p>Falls on a rock slide, no permanent monument established.</p> <p style="text-align: center;">Thence S. 50° 23' W.</p>
42.00	Point for a Cor. of Tract A, hereinafter surveyed.
99.66	Point selected for the witness cor. to Cor. No. 4.
612.92	<p>Falls on top of a granite boulder, 48 x 26 ins., 36 ins. above ground, mkd. X-WC JD 4 20220A.</p> <p>Intersect Cor. No. 3, M.S. No. 19142 I.X.L. lode, identical with line 6-1, M.S. No. 19910 Golden lode, at a point from which Cor. No. 2, M.S. No. 19142 I.X.L. lode, on line 6-1, M.S. No. 19910 Golden lode, bears S. 28° 33' E., 300.00 ft. dist. and Cor. No. 1, M.S. No. 19910 Golden lode, bears N. 28° 33' W., 96.46 ft. dist., all hereinafter described.</p>
1,500.00	Cor. No. 1, identical with Cor. No. 1 of the Prince lode of this survey and place of beginning.
	<hr/> <p><b>PRINCE LODE</b></p>
	<p>From Cor. No. 1 of the Prince lode, identical with Cor. No. 1 of the Jim Dandy lode of this survey, heretofore described.</p> <p style="text-align: center;">Thence N. 28° 50' W., identical with line 1-2, Jim Dandy lode.</p> <p>Some intervening items are described in the survey of the Jim Dandy lode.</p>
267.95	Lode line; discovery point bears S. 42° 25' W., 849 ft. dist., hereinafter described.
535.90	Cor. No. 2, identical with Cor. No. 2 of the Jim Dandy lode of this survey, heretofore described.
	Thence S. 41° 58' W.
215.30	Intersect line 1-2, M.S. No. 19557 Alley lode, at a point from which Cor. No. 1 bears S. 45° 30' E., 149.14 ft. dist. and point for Cor. No. 2 bears N. 45° 30' W., 150.86 ft. dist., both hereinafter described.
360.	Road, gravel, 16 ft. wide, bears S. 15° E. and N. 15° W.
598.76	Intersect line 1-2, M.S. No. 4923 Idella lode, at a point from which Cor. No. 1 bears N. 24° 48' E., 399.35 ft. dist. and point for Cor. No. 2 bears S. 24° 48' W., 1,100.65 ft. dist., both hereinafter described.




Mineral Survey No. 20220 A  
T. 16 S., R. 80 W., Sixth Principal Meridian, Colorado

FEET	
756.32	Intersect line 4-1, Protector lode of this survey, at a point from which Cor. No. 4 bears N. 47° 49' E., 1431.05 ft. dist. and Cor. No. 1 bears S. 47° 49' W., 68.95 ft. dist., both hereinafter described.
782.15	Intersect line bet. secs. 7 and 18, at a point from which the cor. of secs. 7, 8, 17, and 18 bears S. 89° 16' E., 606.05 ft. dist. and the ¼ sec. cor. of secs. 7 and 18 bears N. 89° 16' W., 1,996.21 ft. dist., both hereinafter described.
900.	Chalk Creek, 18 ft. wide, course S. 40° E.
930.	Road, dirt, 16 ft. wide, bears S. 40° E. and N. 40° W.
1,504.00	Point for Cor. No. 3.  Set a stainless steel post, 28 ins. long, 2½ ins. diam., 23 ins. in the ground, with brass cap mkd.
	 <p style="margin-left: 100px;">MS 20220A     /    \       PRI 3       \       2009</p>
	from which  A corner of the location bears N. 28° 50' W., 12.5 ft. dist., hereinafter described.  A silver spruce, 14 ins. diam., bears N. 10° 00' E., 15.0 ft. dist. to face, mkd. PRI 3 20220A XBT.  A yellow pine, 26 ins. diam., bears S. 45° 00' E., 22.5 ft. dist. to face, mkd. PRI 3 20220A XBT.  Thence S. 28°50' E.
255.45	Lode line; discovery point bears N. 42° 25' E., 651 ft. dist., hereinafter described.
331.80	Intersect line 1-2, M.S. No. 4923 Idella lode, at a point from which Cor. No. 1 bears N. 24° 48' E., 1,461.00 ft. dist. and point for Cor. No. 2 bears S. 24° 48' W., 39.00 ft. dist., both hereinafter described.
507.30	Point for Cor. No. 4.  Set a brass tablet, ¾ ins. diam., ¾-in. stem, in a concrete post, 24 ins. long, 6 ins. sq., 16 ins. in the ground, with top mkd.




Mineral Survey No. 20220 A  
 T. 16 S., R. 80 W., Sixth Principal Meridian, Colorado

FEET	
	MS 20220A PRI 4  2009
	from which  A corner of the location bears S. 28° 50' E., 16.1 ft. dist., hereinafter described.  A point on a granite bedrock outcrop, even with the general surface of the ground, bears S. 26° 00' E., 20.0 ft. dist., mkd. XBO PRI 4 20220A.  Thence N. 43° 00' E.
220.00	Cor. No. 2, Dump Millsite of this survey.
480.	Creek, 2 ft. wide, course N.
665.	Road, dirt, 16 ft. wide, bears S. 55° E. and N. 55° W.
780.	Chalk Creek, 16 ft. wide, course S. 50° E.
880.00	Cor. No. 1, Dump Millsite of this survey.
1,084.80	Intersect line 1-2, M.S. No. 19142 I.X.L. lode, at a point from which Cor. No. 2 bears N. 61° 27' E., 1,259.50 ft. dist. and point for Cor. No. 1 bears S. 61° 27' W., 240.50 ft. dist., both hereinafter described.
1,110.	Road, asphalt, 16 ft. wide, bears S. 40° E. and N. 40° W.
1,237.60	Intersect the line bet. secs. 17 and 18, at a point from which the cor. of secs. 7, 8, 17, and 18 bears North, 68.30 ft. dist. and the ¼ sec. cor. of secs. 17 and 18 bears South, 2,582.02 ft. dist., both hereinafter described. Enter patented land.
1,331.00	Intersect the line bet. secs. 8 and 17, at a point from which the W 1/16 sec. cor. of secs. 8 and 17 bears S. 89° 59' E., 1,245.18 ft. dist. and the cor. of secs. 7, 8, 17, and 18 bears N. 89° 59' W., 63.70 ft. dist., both hereinafter described. Leave patented land.
1,494.90	Cor. No. 1, and place of beginning.
	<hr/> <b>PROTECTOR LODGE</b>
	Beginning at Cor. No. 1 of the Protector lode.  Falls on top of a granite rock in place, 56 x 14 ins., 18 ins. above ground, mkd. X PRO 1 20220A; from which



Mineral Survey No. 20220 A  
T. 16 S., R. 80 W., Sixth Principal Meridian, Colorado

FEET	
	<p>The cor. of secs. 7, 8, 17, and 18, bears N. 88° 16' E., 640.10 ft. dist., heretofore described.</p> <p>Cor. No. 1 of the Jim Dandy and the Prince lodes of this survey, bears N. 80° 19' E., 827.10 ft. dist., heretofore described.</p> <p>Thence N. 42° 11' W.</p>
37.49	Intersect line bet. secs. 7 and 18, at a point from which the cor. of secs. 7, 8, 17, and 18 bears S. 89° 16' E., 665.07 ft. dist. and the ¼ sec. cor. of secs. 7 and 18 bears N. 89° 16' W., 1,937.19 ft. dist., both hereinafter described.
245.44	Intersect line 3-4, M.S. No. 4923 Idella lode, at a point from which Cor. No. 4 bears N. 24° 48' E., 518.26 ft. dist. and Cor. No. 3 bears S. 24° 48' W., 981.74 ft. dist., both hereinafter described.
300.00	Lode line; discovery point bears N. 47° 49' E., 73 ft. dist., hereinafter described.
320.	Chalk Creek, 20 ft. wide, course South.
600.00	Cor. No. 2.
	<p>Set a stainless steel post, 28 ins. long, 2½ ins. diam., 24 ins. in the ground, with brass cap mkd.</p> <div style="text-align: center;">  <p>MS 20220A PRO 2 2009</p> </div> <p>from which</p> <p>A yellow pine, 14 ins. diam., bears S. 51° 00' W., 22.0 ft. dist. to face, mkd. PRO 2 20220A XBT.</p> <p>A yellow pine, 12 ins. diam., bears N. 45° 00' W., 35.0 ft. dist. to face, mkd. PRO 2 20220A XBT.</p> <p>Thence N. 47° 49' E.</p>
80.	Chalk Creek, 19 ft. wide, course S. 30° E.
557.88	Intersect line 1-2, M.S. No. 20100 Silver lode, at a point from which Cor. No. 1 bears N. 64° 25' E., 1,312.09 ft. dist., and Cor. No. 2 bears S. 64° 25' W., 187.91 ft. dist., both hereinafter described.
625.	Road, gravel, 16 ft. wide, bears S. 20° E. and N. 20° W.





Mineral Survey No. 20220 A  
 T. 16 S., R. 80 W., Sixth Principal Meridian, Colorado

FEET 1,390.00	<p>Point selected for the witness cor. to Cor. No. 3.</p> <p>At a point 5 ft. above the base of a granite cliff, 120 ft. high, facing S. 10° E., mkd. X WC PRO 3 20220A.</p>
1,434.44	<p>Intersect line bet. secs. 7 and 8, at a point from which the cor. of secs. 5, 6, 7, and 8 bears N. 0° 50' E., 3,924.92 ft. dist. and the cor. of secs. 7, 8, 17, and 18 bears S. 0° 50' W., 1,388.60 ft. dist., both hereinafter described.</p>
1,500.00	<p>Cor. No. 3.</p> <p>Falls at an inaccessible point on the cliff, described above, no permanent monument established.</p> <p style="text-align: center;">Thence S. 42° 11' E.</p>
40.	<p>Base of cliff, bears N. 80° E. and S. 80° W.</p>
280.77	<p>Intersect line 1-2, M.S. No. 20100 Silver lode, at a point from which Cor. No. 1 bears N. 64° 25' E., 329.02 ft. dist. and Cor. No. 2 bears S. 64° 25' W., 1,170.98 ft. dist., both hereinafter described.</p>
300.00	<p>Lode line; discovery point bears S. 47° 49' W., 1,427 ft. dist., hereinafter described.</p>
342.02	<p>Intersect line 2-3, M.S. No. 19557 Alley lode, at a point from which point for Cor. No. 3 bears N. 44° 30' E., 596.95 ft. dist. and point for Cor. No. 2 bears S. 44° 30' W., 903.05 ft. dist., both hereinafter described.</p>
553.30	<p>Intersect line 2-3, Jim Dandy lode of this survey, at a point from which Cor. No. 3 bears N. 50° 23' E., 820.68 ft. dist. and Cor. No. 2 bears S. 50° 23' W., 679.32 ft. dist., both heretofore described.</p>
600.00	<p>Cor. No. 4.</p> <p>Set a stainless steel post, 28 ins. long, 2½ ins. diam., 12 ins. in the ground and in a mound of stone, 3 ft. base to top, with brass cap, mkd.</p> <p style="text-align: center;">             MS 20220A              PRO 4              2009         </p> <p style="text-align: center;">Thence S. 47° 49' W.</p>
625.39	<p>Intersect line bet. secs. 7 and 8, at a point from which the cor. of secs. 5, 6, 7, and 8 bears N. 0° 50' E., 4,745.51 ft. dist. and the cor. of secs. 7, 8, 17, and 18 bears S. 0° 50' W., 568.01 ft. dist., both hereinafter described.</p>





Mineral Survey No. 20220 A  
T. 16 S., R. 80 W., Sixth Principal Meridian, Colorado

FEET 696.94	Intersect common line 1-2, Jim Dandy and Prince lodes of this survey, at a point from which common Cors. No. 1 bears S. 28° 50' E., 456.67 ft. dist. and common Cors. No. 2 bears N. 28° 50' W., 79.23 ft. dist., heretofore described.
889.61	Intersect line 1-2, M.S. No. 19557 Alley lode, at a point from which Cor. No. 1 bears S. 45° 30' E., 93.94 ft. dist. and point for Cor. No. 2 bears N. 45° 30' W., 206.06 ft. dist., both hereinafter described.
1,050.	Road, gravel, 16 ft. wide, bears S. 15° E. and N. 15° W.
1,312.10	Intersect line 1-2, M.S. No. 4923 Idella lode, at a point from which Cor. No. 1 bears N. 24° 48' E., 440.63 ft. dist. and point for Cor. No. 2 bears S. 24° 48' W., 1,059.37 ft. dist., both hereinafter described.
1,431.05	Intersect line 2-3, Prince lode of this survey, at a point from which Cor. No. 2 bears N. 41° 58' E., 756.32 ft. dist. and Cor. No. 3 bears S. 41° 58' W., 747.68 ft. dist., both heretofore described.
1,459.68	Intersect line bet. secs. 7 and 18, at a point from which the cor. of secs. 7, 8, 17, and 18 bears S. 89° 16' E., 610.01 ft. dist. and the ¼ sec. cor. of secs. 7 and 18 bears N. 89° 16' W., 1,992.25 ft. dist., both hereinafter described.
1,500.00	Cor. No. 1, and place of beginning.
<hr/> <b>Mineral Survey No. 20220 B</b> <hr/>	
<b>DUMP MILLSITE</b>	
Beginning at Cor. No. 1 of the Dump Millsite, on line 4-1, Prince lode of this survey.	
Set a brass tablet, 3¼ ins. diam., 3½-in. stem, in a concrete post, 24 ins. long, 6 ins. sq., 16 ins. in the ground, and in a mound of stone, 3 ft. base to top, with top mkd.	
from which	
The cor. of secs. 7, 8, 17, and 18, bears N. 36° 28' E., 410.30 ft. dist., hereinafter described.	
Thence S. 43° 00' W., identical with line 4-1, Prince lode.	



Mineral Survey No. 20220 B  
 T. 16 S., R. 80 W., Sixth Principal Meridian, Colorado

FEET	Intervening items are described in the survey of Prince lode.
660.00	<p>Cor. No. 2, on line 4-1, Prince lode of this survey.</p> <p>Occupied by a yellow pine, 18 ins. diam., mkd. DMS-2-20220B; from which</p> <p style="text-align: center;">A yellow pine, 18 ins. diam., bears S. 80° 00' E., 17.5 ft. dist. to face,              mkd. DMS 2 20220B XBT.</p> <p style="text-align: center;">Thence S. 47° 00' E.</p>
220.	Creek, 2 ft. wide, course N. 50° E.
330.00	<p>Cor. No. 3.</p> <p>Set a stainless steel post, 28 ins. long, 2½ ins. diam., 12 ins. in the ground to bedrock, and in a mound of stone, 3 ft. base to top, mkd.</p> <p style="text-align: center;">MS 20220B              DMS 3                2009</p> <p>No bearing objects or bearing trees available.</p> <p style="text-align: center;">Thence N. 43° 00' E.</p>
390.	Road, dirt, 16 ft. wide, bears S. 40° E. and N. 40° W.
430.	Chalk Creek, 20 ft. wide, course S. 35° E.
660.00	<p>Cor. No. 4.</p> <p>Set a stainless steel post, 28 ins. long, 2½ ins. diam., 14 ins. in the ground to bedrock, and in a mound of stone, 3 ft. base to top, mkd.</p> <p style="text-align: center;">MS 20220B              DMS 4                2009</p> <p>from which</p> <p style="text-align: center;">A yellow pine, 16 ins. diam., bears N. 15° 00' E., 20.5 ft. dist. to face,              mkd. DMS 4 20220B XBT.</p> <p style="text-align: center;">Thence N. 47° 00' W.</p>



Mineral Survey No. 20220 B  
T. 16 S., R. 80 W., Sixth Principal Meridian, Colorado

FEET 330.00	<p>Cor. No. 1, and place of beginning.</p> <p>The Dump Millsite contains 5.00 acres.</p> <hr/> <p style="text-align: center;"><b>Mineral Survey No. 20220 A and B</b></p> <hr/> <p style="text-align: center;"><b>AREAS</b></p> <table style="width: 100%; border-collapse: collapse;"> <thead> <tr> <th style="width: 80%;"></th> <th style="text-align: right; width: 20%;">Acres</th> </tr> </thead> <tbody> <tr> <td>Total area, Jim Dandy lode . . . . .</td> <td style="text-align: right;">18.129</td> </tr> <tr> <td>Area in conflict with —</td> <td></td> </tr> <tr> <td>Tract A, hereinafter described . . . . .</td> <td style="text-align: right;">0.450</td> </tr> <tr> <td>M.S. No. 12071 Major lode . . . . .</td> <td style="text-align: right;">1.095</td> </tr> <tr> <td>M.S. No. 19142 I. X. L. lode . . . . .</td> <td style="text-align: right;">1.708</td> </tr> <tr> <td>M.S. No. 19557 Alley lode. . . . .</td> <td style="text-align: right;">2.815</td> </tr> <tr> <td>M.S. No. 19557 Alley lode, exclusive of its conflict with M.S. No. 12071 Major lode. . . . .</td> <td style="text-align: right; vertical-align: bottom;">2.767</td> </tr> <tr> <td>M.S. No. 19910 Golden lode . . . . .</td> <td style="text-align: right;">1.572</td> </tr> <tr> <td>M.S. No. 19910 Golden lode, exclusive of its conflict with Tract A . . . . .</td> <td style="text-align: right; vertical-align: bottom;">1.122</td> </tr> <tr> <td>M.S. No. 20062 Copper lode . . . . .</td> <td style="text-align: right;">0.357</td> </tr> <tr> <td>M.S. No. 20062 Copper lode, exclusive of its conflict with:</td> <td></td> </tr> <tr> <td>    (1) M.S. No. 12071 Major lode . . . . .</td> <td style="text-align: right;">0.082</td> </tr> <tr> <td>    (2) M.S. No. 19557 Alley lode. . . . .</td> <td style="text-align: right;">0.246</td> </tr> <tr> <td>    (3) M.S. Nos. 12071 and 19557 Major and Alley lodes . . . . .</td> <td style="text-align: right;">0.030</td> </tr> <tr> <td> Total area, Prince lode . . . . .</td> <td style="text-align: right; vertical-align: bottom;"> 17.008</td> </tr> <tr> <td>Area in conflict with —</td> <td></td> </tr> <tr> <td>NW¼ NW¼ sec. 17 . . . . .</td> <td style="text-align: right;">0.050</td> </tr> <tr> <td>M.S. No. 4923 Idella lode . . . . .</td> <td style="text-align: right;">3.258</td> </tr> <tr> <td>M.S. No. 19142 I. X. L. lode . . . . .</td> <td style="text-align: right;">3.744</td> </tr> <tr> <td>M.S. No. 19142 I. X. L. lode, exclusive of its conflict with NW¼ NW¼ sec. 17 . . . . .</td> <td style="text-align: right; vertical-align: bottom;">3.694</td> </tr> <tr> <td>M.S. No. 19557 Alley lode. . . . .</td> <td style="text-align: right;">0.675</td> </tr> <tr> <td> Total area, Protector lode. . . . .</td> <td style="text-align: right; vertical-align: bottom;"> 20.661</td> </tr> <tr> <td>Area in conflict with —</td> <td></td> </tr> <tr> <td>M.S. No. 4923 Idella lode . . . . .</td> <td style="text-align: right;">3.826</td> </tr> <tr> <td>M.S. No. 19557 Alley lode. . . . .</td> <td style="text-align: right;">4.776</td> </tr> <tr> <td>M.S. No. 20100 Silver lode . . . . .</td> <td style="text-align: right;">3.036</td> </tr> <tr> <td>Jim Dandy lode of this survey . . . . .</td> <td style="text-align: right;">0.981</td> </tr> <tr> <td>Jim Dandy lode of this survey, exclusive of its conflict with M.S. No. 19557 Alley lode . . . . .</td> <td style="text-align: right; vertical-align: bottom;">0.000</td> </tr> <tr> <td>Prince lode of this survey. . . . .</td> <td style="text-align: right;">0.650</td> </tr> </tbody> </table>		Acres	Total area, Jim Dandy lode . . . . .	18.129	Area in conflict with —		Tract A, hereinafter described . . . . .	0.450	M.S. No. 12071 Major lode . . . . .	1.095	M.S. No. 19142 I. X. L. lode . . . . .	1.708	M.S. No. 19557 Alley lode. . . . .	2.815	M.S. No. 19557 Alley lode, exclusive of its conflict with M.S. No. 12071 Major lode. . . . .	2.767	M.S. No. 19910 Golden lode . . . . .	1.572	M.S. No. 19910 Golden lode, exclusive of its conflict with Tract A . . . . .	1.122	M.S. No. 20062 Copper lode . . . . .	0.357	M.S. No. 20062 Copper lode, exclusive of its conflict with:		(1) M.S. No. 12071 Major lode . . . . .	0.082	(2) M.S. No. 19557 Alley lode. . . . .	0.246	(3) M.S. Nos. 12071 and 19557 Major and Alley lodes . . . . .	0.030	 Total area, Prince lode . . . . .	 17.008	Area in conflict with —		NW¼ NW¼ sec. 17 . . . . .	0.050	M.S. No. 4923 Idella lode . . . . .	3.258	M.S. No. 19142 I. X. L. lode . . . . .	3.744	M.S. No. 19142 I. X. L. lode, exclusive of its conflict with NW¼ NW¼ sec. 17 . . . . .	3.694	M.S. No. 19557 Alley lode. . . . .	0.675	 Total area, Protector lode. . . . .	 20.661	Area in conflict with —		M.S. No. 4923 Idella lode . . . . .	3.826	M.S. No. 19557 Alley lode. . . . .	4.776	M.S. No. 20100 Silver lode . . . . .	3.036	Jim Dandy lode of this survey . . . . .	0.981	Jim Dandy lode of this survey, exclusive of its conflict with M.S. No. 19557 Alley lode . . . . .	0.000	Prince lode of this survey. . . . .	0.650
	Acres																																																												
Total area, Jim Dandy lode . . . . .	18.129																																																												
Area in conflict with —																																																													
Tract A, hereinafter described . . . . .	0.450																																																												
M.S. No. 12071 Major lode . . . . .	1.095																																																												
M.S. No. 19142 I. X. L. lode . . . . .	1.708																																																												
M.S. No. 19557 Alley lode. . . . .	2.815																																																												
M.S. No. 19557 Alley lode, exclusive of its conflict with M.S. No. 12071 Major lode. . . . .	2.767																																																												
M.S. No. 19910 Golden lode . . . . .	1.572																																																												
M.S. No. 19910 Golden lode, exclusive of its conflict with Tract A . . . . .	1.122																																																												
M.S. No. 20062 Copper lode . . . . .	0.357																																																												
M.S. No. 20062 Copper lode, exclusive of its conflict with:																																																													
(1) M.S. No. 12071 Major lode . . . . .	0.082																																																												
(2) M.S. No. 19557 Alley lode. . . . .	0.246																																																												
(3) M.S. Nos. 12071 and 19557 Major and Alley lodes . . . . .	0.030																																																												
 Total area, Prince lode . . . . .	 17.008																																																												
Area in conflict with —																																																													
NW¼ NW¼ sec. 17 . . . . .	0.050																																																												
M.S. No. 4923 Idella lode . . . . .	3.258																																																												
M.S. No. 19142 I. X. L. lode . . . . .	3.744																																																												
M.S. No. 19142 I. X. L. lode, exclusive of its conflict with NW¼ NW¼ sec. 17 . . . . .	3.694																																																												
M.S. No. 19557 Alley lode. . . . .	0.675																																																												
 Total area, Protector lode. . . . .	 20.661																																																												
Area in conflict with —																																																													
M.S. No. 4923 Idella lode . . . . .	3.826																																																												
M.S. No. 19557 Alley lode. . . . .	4.776																																																												
M.S. No. 20100 Silver lode . . . . .	3.036																																																												
Jim Dandy lode of this survey . . . . .	0.981																																																												
Jim Dandy lode of this survey, exclusive of its conflict with M.S. No. 19557 Alley lode . . . . .	0.000																																																												
Prince lode of this survey. . . . .	0.650																																																												



Mineral Survey No. 20220 A and B  
T. 16 S., R. 80 W., Sixth Principal Meridian, Colorado

Prince lode of this survey, exclusive of its conflict with:

- (1) M.S. No. 4923 Idella lode .....0.628
- (2) M.S. No. 19557 Alley lode .....0.342
- (3) M.S. Nos. 4923 and 19557 Idella and Alley lodes .....0.320

Total area, Dump Millsite ..... 5.000

**TRACT A**

That portion of M.S. No. 19910 Golden lode in conflict with Jim Dandy lode of this survey, excluded by said Golden lode in favor of a location now abandoned, is bounded and described as follows:

Beginning at Cor. No. 4 of the Jim Dandy lode —  
Thence N. 28° 50' W., identical with line 4-3, Jim Dandy lode, 131.40 ft., to line 1-2, M.S. No. 19910 Golden lode;  
Thence S. 47° 12' W., identical with line 2-1, M.S. 19910 Golden lode, 275.60 ft., to a point;  
Thence N. 79° 00' E., 237.60 ft., to line 4-1, Jim Dandy lode;  
Thence N. 50° 23' E., identical with line 1-4, Jim Dandy lode, 42.00 ft., to place of beginning.

Tract A contains 0.450 acres.

**LOCATION**

This survey is located in the E½ SE¼ sec. 7, SE¼ SW¼ and W½ SW¼ sec. 8, NW¼ NW¼ sec. 17, and NE¼ NE¼ sec. 18, of T. 16 S., R. 80 W., Sixth Principal Meridian, Chaffee County, Colorado.

The survey of the Jim Dandy and Protector lodes and the Dump Millsite is identical with the notice of location or amended notice of location and as marked on the ground. The survey of the Prince lode is wholly within the amended notice of location and as marked on the ground; Cor. Nos. 1 and 2 are identical with corners of the location; Cor. Nos. 3 and 4 differ to the extent previously shown; both hereinafter described.

Location survey corners Jim Dandy lode:

Cor. No. 1, identical with Cor. No. 1, Prince lode, monumented with a wood post, 4 ins. sq., firmly set, projecting 4 ft. above ground, mkd. JD 1 on NE side and PRI 1 on the NW side.

Cor. No. 2, identical with Cor. No. 2, Prince lode, monumented with a granite stone, 30 ins. x 24 ins., firmly set, projecting 12 ins. above ground, mkd. JD 2 on the SE side and PRI 2 on the SW side.

Cor. No. 3, monumented with a wood post, 4 ins. sq., firmly set, projecting 4 ft. above ground and in a mound of stone, 6 ft. base, 5 ft. high, with an aluminum flasher mkd. JD 3.

Cor. No. 4, determined from the location survey witness cor., on line 3-4, 99.66 ft. dist., from the witness cor., which is a point on top of a granite boulder, 48 x 26 ins., 36 ins. above ground, mkd X-WCJD, falls on a rock slide.





Mineral Survey No. 20220 A and B  
T. 16 S., R. 80 W., Sixth Principal Meridian, Colorado

	<p>Location survey corners Prince lode: Cors. 1 and 2 heretofore described. Cors. 3 and 4 hereinafter described.</p> <p>Location survey corners Protector lode: Cor. No. 1, monumented with an unmarked pine post, 8 ins. diam., loosely set, projecting 6 ft. above ground and in a mound of stone, 4 ft. base, 3 ft. high. Cor. No. 2, monumented with a wood stake, 2 ins. x 4 ins., firmly set, projecting 4 ft. above ground, mkd. PRO 2 on E. side. Cor. No. 3, determined from the location survey witness cor., on line 2-3, 110.00 ft. dist., from the witness cor., which is a point 5 ft. above the base of a granite cliff, 120 ft. high, facing S. 10° E., mkd. XWCPRO3, falls at an inaccessible point on the cliff. Cor. No. 4, monumented with an iron rod, ¾ in. diam., firmly set, projecting 12 ins. above ground.</p> <p>Location survey corners Dump Millsite: Cor. No. 1, monumented with a mound of stone, 4 ft. base, 3 ft. high. Cor. No. 2, monumented with a yellow pine, 18 ins. diam, mkd. DMS-2 on E. side. Cor. No. 3, monumented with a sandstone, 24 ins. x 18 ins., firmly set, projecting 12 ins. above ground and in a mound of stone, 3 ft. base to top, no marks visible. Cor. No. 4, monumented with a pine post, 4 ins. diam., firmly set, projecting 4 ft. above ground, with aluminum tag mkd. DMS4.</p> <p style="text-align: center;"><b>EXPENDITURES</b></p> <p>The improvements and the value of the labor and improvements made upon or for the benefit of each of the lode locations embraced in said mining claim by the claimant or its grantors are as follows:</p> <p style="text-align: center;"><u>Jim Dandy lode</u></p> <p>No. 1 The discovery cut of the Jim Dandy lode, the face of which being the discovery point, is on the lode line N. 50° 23' E., 496 ft. dist. from a point on line 1-2, 301.30 ft. dist. from Cor. No. 1; 6 ft. wide, 15 ft. face, runs N. 50° 23' E., 30 ft. dist. to face and portal of tunnel, 5 x 7 ft. in size, running N. 50° E., 23 ft. dist. to breast; at breast is a winze, 5 x 5 ft., 20 ft. deep; tunnel and winze timbered. Value of cut, tunnel, and winze, \$380.</p> <p>No. 2 A tunnel, 5 x 7 ft. in size, the portal of which bears N. 70° 57' E., 374 ft. dist. from Cor. No. 2, Jim Dandy lode, and runs N. 51° 03' E., 148 ft. dist., thence N. 31° 45' E., 18 ft. dist., thence N. 50° 31' E., 49 ft. dist. to breast; partly caved. Value, \$2,300.</p> <p>No. 3 A trench, the west end of which bears N. 38° 12' E., 395 ft. dist. from Cor. No. 1, Jim Dandy lode; 4 ft. wide, 8 ft. deep, running N. 48° E., 40 ft. dist. Value, \$125.</p>
--	--



Mineral Survey No. 20220 A and B  
T. 16 S., R. 80 W., Sixth Principal Meridian, Colorado

<p>No. 1</p>	<p style="text-align: center;"><u>Prince lode</u></p> <p>The discovery cut of the Prince lode, the face of which being the discovery point, is on the lode line S. 42° 25' W., 849 ft. dist. from the center of line 1-2; 6 ft. wide, 13 ft. face; running N. 42° 25' E., 20 ft. dist. to face. Value, \$100.</p>
<p>No. 2</p>	<p>A shaft, the center of which bears N. 20° 42' E., 450 ft. dist. from Cor. No. 4, Prince lode; 4 x 7 ft., 3 ft. deep. Value, \$130.</p>
<p>No. 1</p>	<p style="text-align: center;"><u>Protector lode</u></p> <p>The discovery cut of the Protector lode, the center of which being the discovery point, is on the center line, N. 47° 49' E., 73 ft. dist. from the center of line 1-2; 6 x 8 ft., 18 ft. deep, partly timbered. Value, \$200.</p>
<p><b>COMMON IMPROVEMENT</b></p>	
<p>An interest in a common improvement described as follows:</p>	
<p>A tunnel, 6 x 7 ft. in size, the portal of which bears S. 34° 00' W., 668 ft. dist. from Cor. No. 1, Prince lode; running N. 3° 30' E., 230 ft. dist. to Sta. 1; thence N. 23° 30' E., 280 ft. dist. to pt. A and 350 ft. dist. to Sta. 2; thence N. 7° 45' E., 19 ft. dist. to pt. B, 100 ft. dist. to pt. C, and 210 ft. dist. to breast at date of survey. At pt. A, a drift, 5 x 7 ft. in size, runs N. 74° 30' E., 56 ft. dist. to breast. At pt. B, a drift, 5 x 7 ft. in size, runs N. 58° E., 71 ft. dist. to breast and foot of raise, 5 x 5 ft., 16 ft. high. At pt. C is the beginning of a stope, 70 ft. long, 4 ft. wide, and averaging 30 ft. in height. Value of tunnel, drifts, raise, and stope, \$14,200. Value of one-eighth interest, \$1,775.</p>	
<p>This improvement is in course of construction for the development of the three lodes of this survey and M.S. No. 19142 I.X.L. lode, M.S. No. 19910 Golden lode, M.S. No. 20100 Silver lode, and the Lead King and Daisy lodes, unsurveyed, which are all the contiguous lode claims owned in common within the range of benefit of said tunnel.</p>	
<p>The surface rises rapidly to the north and east from the portal of the tunnel, and the extension in its present course, with necessary laterals, affords the most practical and economical means of developing each of the stated lodes at depth.</p>	
<p>Five hundred dollars or over has been expended in this improvement in such a manner as tends to the development of each lode of this survey subsequent to its location and to the time since which common ownership and contiguity have prevailed; therefore an undivided one-eighth interest in its value is hereby credited to each of said lodes and a like interest apportioned to each of the other stated lodes of the common group.</p>	
<p>The first 165 ft. dist. of this tunnel, valued at \$2,400 was credited to M.S. No. 19142 I.X.L. lode.</p>	



Mineral Survey No. 20220 A and B  
T. 16 S., R. 80 W., Sixth Principal Meridian, Colorado

An undivided one-half interest in the first 290 ft. dist., valued at \$2,200, was credited to M.S. No. 19910 Golden lode.

An undivided one-fifth interest in the first 510 ft. dist., valued at \$1,520, was credited to M.S. No. 20100 Silver lode.

Except as above stated, no portion of or interest in this improvement has been credited heretofore as patent expenditure to any lode claim.

#### OTHER IMPROVEMENTS

A cut, 6 ft. wide, the face of which bears S. 17° 42' W., 402 ft. dist. from Cor. No. 2, Prince lode, runs East, 20 ft. dist., to 12 ft. face.

A shaft, 4 x 6 ft., 10 ft. deep, the center of which bears N. 37° 17' E., 318 ft. dist. from Cor. No. 1, Jim Dandy lode.

Claimant of each unknown.

A plank ore bin, 14 x 20 ft., 3 ft. deep, the N. corner of which bears S. 3° 00' W., 210 ft. dist. from Cor. No. 1, Dump Millsite; the long sides bears N. 20° W.

Claimant herein.

A frame compressor house and shop, the NE corner of which bears S. 25° 00' E., 80 ft. dist. from Cor. No. 1, Dump Millsite; 16 x 30 ft. in size; the long sides bears N. 85° W.

Claimant herein.

A frame bunkhouse, the NE corner of which bears S. 50° 00' W., 690 ft. dist. from Cor. No. 1, Prince lode; 20 x 50 ft. in size; the long sides bears N. 85° W.

Claimant herein.

A bridge, the east end of which bears S. 3° 00' W., 153 ft. dist. from Cor. No. 1, Dump Millsite; of logs and planks, 10 ft. wide and 30 ft. long, bears N. 50° E. and S. 50° W.

Claimant herein.

#### OTHER CORNER DESCRIPTIONS AND SUPPLEMENTAL DATA

The history of official surveys pertaining to this survey is as follows:

Lawrence H. Muller, Mineral Surveyor, surveyed canceled M.S. No. 492 Green Ranger lode in 1877, as shown on the official plat of survey accepted October 30, 1877.

Philip J. Porter, Mineral Surveyor, surveyed M.S. No. 4923 Idella lode in 1880, as shown on the official plat of survey accepted June 4, 1880.

Walter L. Hunnemiller, U.S. Deputy Surveyor, surveyed the subdivisional lines in 1881, as shown on the official plat of survey accepted June 30, 1882.



Mineral Survey No. 20220 A and B  
T. 16 S., R. 80 W., Sixth Principal Meridian, Colorado

Davidson Hull, Mineral Surveyor, surveyed M.S. No. 12071 Major lode in 1886, as shown on the official plat of survey accepted February 8, 1887.

Otto P. Carter, Mineral Surveyor, surveyed M.S. No. 18837 C.O.D. lode in 1904, as shown on the official plat of survey accepted August 4, 1904.

Frank M. Jackson, Mineral Surveyor, surveyed M.S. No. 19142 I.X.L. lode in 1904, as shown on the official plat of survey accepted July 23, 1905.

John M. More, Mineral Surveyor, surveyed M.S. No. 19557 Alley lode in 1905, as shown on the official plat of survey accepted March 18, 1906.

John U. Threadwell, Mineral Surveyor, surveyed M.S. No. 19910 Golden lode in 1907, as shown on the official plat of survey accepted May 19, 1907.

Ernest P. Rand, Mineral Surveyor, surveyed M.S. No. 20062 Copper lode in 1907, as shown on the official plat of survey accepted December 24, 1907.

Thomas A. Till, Mineral Surveyor, surveyed M.S. No. 20100 Silver lode in 1907, as shown on the official plat of survey accepted April 1, 1908.

Arthur A. Johnson, Cadastral Surveyor, resurveyed a portion of the subdivisional lines in 1973, under Group No. 698, as shown on the official plat of survey accepted January 31, 1974.

The U.S. MINERAL MONUMENT – SPORPHYRY; at Latitude 38° 44' 51.066" N. and Longitude 106° 19' 54.616" W. NAD 83 (CORS96) (EPOCH:2002); established by M.S. No. 492.

Found a granite stone, 10 x 8 ins., projecting 12 ins. above ground, and in a mound of stone, 2 ft. base, to top, mkd. USMM on NW side.

from which the original bearing objects

A granite rock in place, 2½ x 2 ft., 8 ins. above ground, bears S. 44° 40' W., 37.4 ft. dist., mkd. USMM XBO SRY.

A granite rock in place, 2 x 1½ ft., 4 ins. above ground, bears N. 44° 20' W., 166.4 ft. dist., mkd. USMM XBO SRY. (Record, 176.4 ft.)

At the corner point

Set an aluminum post, 28 ins. long, 2½ ins. diam., 23 ins. in the ground, with aluminum cap mkd.

USMM  
SPORPHYRY  
MS 492  
2009

The ¼ sec. cor. of secs. 17 and 18, monumented with an iron post, 2 ins. diam., firmly set, projecting 5 ins. above ground, with brass cap mkd. T16S R80W 1/4 S17 S18 1973; as described in the dependent resurvey by Arthur A. Johnson, Cadastral Surveyor, accepted January 31, 1974.



Mineral Survey No. 20220 A and B  
T. 16 S., R. 80 W., Sixth Principal Meridian, Colorado

The cor. of secs. 7, 8, 17, and 18, monumented with an iron post, 2 ins. diam., firmly set, projecting 12 ins. above ground, with brass cap mkd. T16S R80W S7 S8 S17 S18 1973, with a mound of stone, 3 ft. base, 2 ft. high, W. of the corner; as described in the dependent resurvey by Arthur A. Johnson, Cadastral Surveyor, accepted January 31, 1974.

The  $\frac{1}{4}$  sec. cor. of secs. 8 and 17, remonumented with an aluminum tablet, 4 ins. diam., firmly set in concrete, flush with the surface of the ground, mkd. T16S R80W  $\frac{1}{4}$  S8 S17 1974; by Charles M. Gesner, Registered Land Surveyor No. 1492, in 1974, as described in Record of Survey No. 26401, Chaffee County Surveyor's Office. This is accepted as a careful and faithful perpetuation of the position of the original corner.

The W  $\frac{1}{16}$  sec. cor. of secs. 8 and 17, established by Charles M. Gesner, Registered Land Surveyor No. 1492, in 1974, as described in Record of Survey No. 26401, Chaffee County Surveyor's Office, with an iron rod,  $\frac{5}{8}$  in. diam., firmly set, projecting 4 ins. above ground, with aluminum cap mkd. W $\frac{1}{16}$  S8 S17 1974. This is accepted as a careful and faithful establishment of the corner position.

The  $\frac{1}{4}$  sec. cor. of secs. 7 and 8 was searched for and no evidence found. Calculated corner position by single proportion; no permanent monument established.

The cor. of secs. 5, 6, 7, and 8, determined from the remains of two original bearing trees; a yellow pine snag, 28 ins. diam., 10 ft. high, bears N.  $10^{\circ}$  E., 50 lks. dist., with healed blaze; and a rotted silver spruce stump, 24 ins. diam., 3 ft. high, bears S.  $70^{\circ}$  E., 75 lks. dist., with truncated healed blaze showing on top; chopped open blaze and found BT scribe marks on 10 ins. core diam. (Record 12 ins. diam., S.  $80^{\circ}$  E.); found no evidence of the remaining original bearing trees. At the corner point, set a stainless steel post, 28 ins. long,  $2\frac{1}{2}$  ins. diam., 23 ins. in the ground and in a mound of stone, 3 ft. base to top, with brass cap mkd. T16S R80W S5 S6 S7 S8 2009; from which a new bearing tree, a yellow pine, 8 ins. diam., bears N.  $42^{\circ}$  W., 109 lks. dist., mkd. T16SR80WS6BT.

The  $\frac{1}{4}$  sec. cor. of secs. 7 and 18, monumented with the original stone, 18 x 12 ins., firmly set, projecting 5 ins. above ground, mkd.  $\frac{1}{4}$  on north face.

The section line bearings are reported as mean bearings.

The line from the  $\frac{1}{4}$  sec. cor. of secs. 17 and 18 to the cor. of secs. 7, 8, 17, and 18 was found to be North, 2,650.32 ft. dist., instead of the record N.  $0^{\circ} 05' W.$ , 2,652.02 ft. dist., as approved in the 1974 dependent resurvey

The line from the  $\frac{1}{4}$  sec. cor. of secs. 8 and 17 to the W  $\frac{1}{16}$  sec. cor. of secs. 8 and 17 was found to be S.  $89^{\circ} 58' W.$ , 1,310.74 ft. dist., instead of S.  $89^{\circ} 54' W.$ , 1,309.90 ft. dist., as shown on Record of Survey No. 1492. The record was West, 1,317.36 ft. dist., by the original 1881 survey.

The line from the W  $\frac{1}{16}$  sec. cor. of secs. 8 and 17 to the cor. of secs. 7, 8, 17, and 18 was found to be N.  $89^{\circ} 59' W.$ , 1,308.88 ft. dist., instead of S.  $89^{\circ} 54' W.$ ,





Mineral Survey No. 20220 A and B  
T. 16 S., R. 80 W., Sixth Principal Meridian, Colorado

1,309.90 ft. dist., as shown on Record of Survey No. 1492. The record was West, 1,317.36 ft. dist., by the original 1881 survey.

The line from the cor. of secs. 7, 8, 17, and 18, to the cor. of secs. 5, 6, 7, and 8, was found to be N. 0° 50' E., 5,313.52 ft. dist., instead of the record North, 5,280 ft. dist., by the original 1881 survey.

The line from the cor. of secs. 7, 8, 17, and 18, to the ¼ sec. cor. of secs. 7 and 18, was found to be N. 89° 16' W., 2,602.26 ft. dist., instead of N. 89° 19' W., 2,603.24 ft. dist., as shown on Record of Survey No. 1785, Chaffee County Surveyor's Office, by Charles M. Mercer, Registered Land Surveyor No. 2020, in 1999. The record was S. 89° 56' W., 2,636.43 ft. dist., by the original 1881 survey.

M.S. No. 4923 Idella lode: Cor. Nos. 1, 3, and 4 are monumented with granite stones, firmly set and properly mkd.; Cor. No. 2 is lost. Line 3-4 was found to be approximately correct as approved; line 4-1 was found to be S. 65° 05' E., 299.40 ft. dist., instead of S. 65° 12' E., 300.00 ft. dist., as approved; line 1-2 shown as approved.

M.S. No. 12071 Major lode: Cor. No. 2 is monumented with a pine post, firmly set and properly mkd. Cor. No. 2 is identical with Cor. No. 4, M.S. No. 20062 Copper lode described below; no other corners could be found. All lines shown as approved. Owing to the absence of Cor. No. 1, the apparent error in the connecting line to the cor. of secs. 7, 8, 17, and 18, could not be verified.

M.S. No. 18837 C.O.D. lode: Cor. No. 3 is monumented with a granite stone, firmly set and properly mkd.

M.S. No. 19142 I.X.L. lode: Cor. Nos. 2, 3, and 4 are monumented with pine posts, firmly set and properly mkd.; Cor. No. 1 could not be found. Lines 2-3 and 3-4 are correct as approved; lines 1-2 and 4-1 are shown as approved.

M.S. No. 19557 Alley lode: Cor. No. 1 is monumented with a pine post and Cor. No. 4 with a granite stone, both firmly set and properly mkd.; Cor. Nos. 2 and 3 are lost. Line 4-1 was found to be S. 44° 30' W., 1,500.00 ft. dist. instead of S. 44° 20' W., 1,500.00 ft. dist., as approved; lines 1-2 and 3-4 are shown at right angles to line 4-1, and each 300.00 ft. dist. as approved; this makes line 2-3, N. 45° 30' E., instead of N. 45° 20' E., as approved, and lines 1-2 and 4-3 each N. 45° 30' W., instead of N. 45° 40' W, as approved. From Cor. No. 4 of the Alley lode, Cor. No. 2, M.S. No. 12071 Major lode, identical with Cor. No. 4, M.S. No. 20062 Copper lode, bears S. 21° 10' W., 128.70 ft. dist., instead of S. 20° 35' W., 136.0 ft. dist., as approved.

M.S. No. 19910 Golden lode: Cor. Nos. 1, 2, and 6 are monumented with granite stones, firmly set and properly mkd. Lines 1-2 and 6-1 are correct as approved.

M.S. No. 20062 Copper lode: Cor. Nos. 1, 2, and 3 are monumented with pine posts, firmly set and properly mkd. Cor. No. 4 is identical with Cor. No. 2, M.S. No. 12071 Major lode, described above. All lines are correct as approved.



Mineral Survey No. 20220 A and B  
T. 16 S., R. 80 W., Sixth Principal Meridian, Colorado

M.S. 20100 Silver lode: Cor. Nos. 1 and 2 are monumented with granite stones, firmly set and properly mkd. Line 1-2 is correct as approved.

**MEMORANDUM**

[EDITOR NOTE.— Here explain any allowable disagreement with the location certificate, and show the cause.]

Location survey corners Prince lode:

Cor. No. 3 is monumented with a pine post, 4 ins. sq., firmly set, projecting 4 ft. above ground and in a collar of stones, mkd. PRI 3 on E. side.

Cor No. 4 is monumented with a mound of stones, 4 ft. base, 3 ft. high.



## CERTIFICATE OF SURVEYOR

I, H. B. Sands, Mineral Surveyor, HEREBY CERTIFY upon honor, that in pursuance of an order received from the Bureau of Land Management, at Denver, Colorado, dated April 9, 2009, I have carefully executed the survey of the claim of The Gold Mining Company, known as the Jim Dandy, Prince, and Protector lodes, and the Dump Millsite, situated in surveyed sections 7, 8, 17, and 18, Township 16 South, Range 80 West, Sixth Principal Meridian, in the State of Colorado.

This survey, designated as number 20220 A and B, has been executed by me and under my direction and has been made in strict conformity with said order, the Manual of Surveying Instructions, and in the specific manner described in the foregoing field notes.

I FURTHER CERTIFY that the labor expended and improvements made upon and for the benefit of the lode locations embraced in the said mining claim by claimants or grantors are fully stated in my report. The character, extent, location, and itemized value are specified in full detail. No portion of, or interest in, said labor and improvements so credited to these claims has been included in the estimate of expenditures upon any other claim.

June 1, 2009

Date

*H. B. Sands*

Mineral Surveyor

## CERTIFICATE OF APPROVAL

BUREAU OF LAND MANAGEMENT  
Denver, Colorado

The foregoing field notes of mineral survey number 20220 A and B, in surveyed sections 7, 8, 17, and 18, Township 16 South, Range 80 West, Sixth Principal Meridian, in the State of Colorado, executed by H. B. Sands, Mineral Surveyor, under order dated April 9, 2009, having been critically examined and the necessary corrections made prior to their certification by the surveyor, the field notes and the survey therein described are hereby approved.

June 22, 2009

Date

*William B. Tellner*

Chief Cadastral Surveyor for Colorado

## CERTIFICATE OF TRANSCRIPT

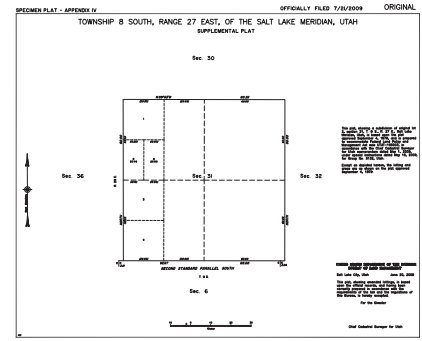
I HEREBY CERTIFY that the foregoing transcript of the field notes of the above described mineral survey number 20220 A and B, in surveyed Township 16 South, Range 80 West, Sixth Principal Meridian, Colorado, is a true copy of the original field notes.

Date

Chief Cadastral Surveyor for Colorado

## Appendix IV

# Supplemental Plat Specimen Plat



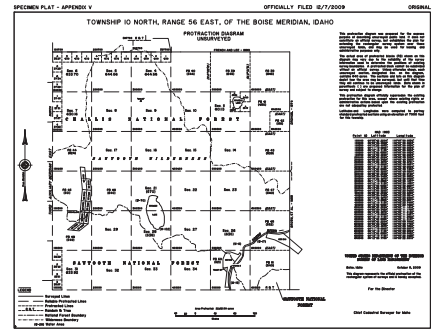
The supplemental plat specimen plat can be found in the pocket inside the back cover.





## Appendix V

# Protraction Diagram Specimen Plat



The protraction diagram specimen plat can be found in the pocket inside the back cover.



# Index

---

## A

- Absentee owner .....161
- Acceptance of survey .....2
- Accessories, corner. *See* Corner accessories
- Accretion .....198–200, 205–209
- case studies .....242–248, 256–259
  - prior to entry .....221, 268–271
  - surveys .....208–212
- Accuracy. *See also* Limits .....36
- amended protraction diagrams .....80
  - bearings .....37
  - coordinates .....35
  - line measurement .....165
  - verification of .....42
- Acquired lands .....4-5, 19
- case studies .....272–282
  - tidewater .....222–223
- Acts
- August 7, 1789 .....20
  - September 2, 1789 .....20
  - May 18, 1796 .....3, 7–8, 20, 285
  - March 1, 1800 .....20–21
  - May 10, 1800 .....8
  - March 26, 1804 .....21
  - February 11, 1805 .....8–9, 21, 147, 181
  - March 3, 1811 .....21
  - April 25, 1812 .....8–9, 21
  - April 24, 1820 .....9, 21
  - May 29, 1830 .....21
  - April 5, 1832 .....9, 21–22
  - June 30, 1834 .....22
  - July 4, 1836 .....22
  - June 12, 1840 .....22
  - August 3, 1846 .....22
  - March 2, 1849 .....7
  - March 3, 1849 .....9
  - September 28, 1850 .....7
  - January 22, 1853 .....22
  - March 3, 1853 .....22
  - March 12, 1860 .....7
  - May 30, 1862 .....22
  - April 8, 1864 .....9
  - July 23, 1866 .....7, 22
  - July 26, 1866 .....350
  - July 9, 1870 .....9, 350
  - May 10, 1872 .....350, 365
  - March 3, 1879 .....9, 23
  - May 17, 1884 .....23, 350
  - July 5, 1884 .....23
  - February 8, 1887 .....23
  - August 20, 1894 .....22
  - February 26, 1895
    - Isolated Tract Act .....22  - June 11, 1896 .....23
  - June 4, 1897 .....23
  - April 29, 1898
    - Arkansas Compromise Act .....7  - March 3, 1899 .....9
  - June 6, 1900 .....350
  - June 17, 1902
    - Reclamation Act .....23, 334–335  - April 28, 1904 .....350
  - February 1, 1905 .....23
  - May 17, 1906 .....23
  - June 11, 1906 .....341
  - June 27, 1906 .....23, 335
  - May 27, 1908 .....23
  - March 3, 1909
    - General Resurvey Act .....9, 18  - March 4, 1909 .....23
  - June 25, 1910 .....9, 341
  - August 10, 1912 .....23
  - September 21, 1918 .....10, 18
  - February 25, 1920
    - Mineral Leasing Act .....345, 347, 350  - May 21, 1920
    - Economy Act .....23  - March 20, 1922 .....341
  - March 3, 1925 .....23–24
  - August 10, 1933 .....351
  - May 4, 1934 .....350
  - May 31, 1938 .....350
  - June 1, 1938 .....343
  - July 7, 1943 .....24
  - July 14, 1945 .....343
  - 1946
    - Administrative Procedure Act .....132  - July 31, 1947 .....350
  - August 8, 1947 .....350
  - 1948
    - Federal Water Pollution Control Act .....188  - 1950
    - Federal Records Act .....24  - 1953
    - Submerged Lands Act .....24, 88, 189–191

- June 8, 1954 .....343
- July 23, 1955
  - Materials Act.....350
  - Surface Resources Act .....350
- July 7, 1958
  - Alaska Statehood Act .....24, 26, 88
- July 31, 1958
  - National Forest Townsite Act .....343
- March 18, 1960
  - Millsite Act.....351
- July 14, 1960
  - Public Land Administration Act .....24
- 1969
  - Federal Mine Health and Safety Acts ....347
- December 18, 1971
  - Alaska Native Claims Settlement Act (ANCSA).....24–25, 337, 340
- 1972
  - Quiet Title Act .....132, 155
- October 21, 1976 .....343
  - Federal Land Policy and Management Act (FLPMA) .....10, 24–25, 351
- 1977
  - Federal Mine Health and Safety Acts ....347
  - Surface Mining Control and Reclamation Act.....347
- December 2, 1980
  - Alaska National Interest Lands Conservation Act (ANILCA).....25–26
- January 12, 1983
  - National Forests System Lands Small Tracts Act.....25, 342
- August 16, 1988
  - Alaska Submerged Lands Act.....25–26
- October 5, 1992 .....10
- August 10, 1993
  - Hardrock Mining Claim Maintenance Fee Act .....351
- December 28, 2000
  - Education Land Grant Act .....343
- November 10, 2003 .....26
- October 18, 2004 .....26
- Adjustment for curvature .....30–31
- Administrative Procedure Act .....132
- Administrative surveys .....2, 157, 333–334
- Admiralty Jurisdiction .....188, 191, 225
- Adverse possession .....158
- Agricultural lands.....5, 19
- Alabama .....15, 90, 181
- Alaska .....15
  - lakes, rivers, and streams .....25–26
  - meandering .....85, 88
  - measurement.....28
  - mining laws .....23
  - Native allotments and surveys .....23
  - navigable waters .....25–26, 192–193
  - PLSS.....9
  - protraction diagrams.....25, 76
  - railroad .....23
  - resurveys.....131
  - townsite surveys .....337–338, 340–341
- Alaska National Interest Lands Conservation Act (ANILCA) of December 2, 1980 .....25–26
- Alaska Native Claims Settlement Act (ANCSA) of December 18, 1971 .....24–26, 337, 340
- Alaska Statehood Act of July 7, 1958 .....24, 26, 88
- Alaska Submerged Lands Act of August 16, 1988 .....25–26
- Alienated lands. *See also* Federal
  - interest lands .....19, 129, 139–140
  - bona fide rights .....162–163
  - fraudulent or erroneous surveys .....159–162
  - as parcels .....329
  - water boundaries .....217–218, 222–223
- Alinement
  - accumulated error .....55
  - allowable deviation .....46–47
  - rectangular limits .....48–49
- Aliquot parts.....47–48, 66, 80
  - Indian allotment surveys .....332
  - supplemental plats .....309
- Allotment surveys .....330–334
- Alluvial rivers .....197–200, 206
- Amended monument .....50
- Amended orders .....362
- Amended protraction diagrams .....76–81
  - cancellation of surveys and townships.....78
  - control positions .....80
  - corner positions .....76–79
  - defined .....76–77
  - methods of construction.....79
  - outboundaries of.....78–79
  - Plan of Survey Coordinates (POSC) .....77–79
  - protracted blocks .....77–78, 80–81
- Amended surveys.....362–363
- Angle of convergence .....29
- Angle points.....84, 108, 117, 126
  - as corners .....148, 171
  - of meander lines .....174–175, 185–186
  - nonrectangular surveys.....336–337
  - resurveys.....139, 141
- Apparent misclosure .....31–32
- Approval of survey .....2
- Aquatic vegetation .....82
- Arc length.....31
- Areas .....32–33



computation of . . . . .299–301  
 on plats . . . . .299–301, 320–321, 327  
 quarter sections . . . . .21  
 units of . . . . .37  
 Arkansas . . . . .15, 90  
 Arkansas Compromise Act of April 29, 1898 . . . . .7  
 Arpent unit . . . . .37  
 Assignment instructions . . . . .285  
 Assistant Secretary—Land and Minerals  
   Management . . . . .11  
 Astronomic meridian . . . . .27–28, 33, 35  
 Auxiliary guide meridian . . . . .43  
 Auxiliary meander corners (AMC) . . . . .83–85, 87–88,  
   117, 120, 125–126  
 Avulsion . . . . .199–205  
   backswamp . . . . .202  
   case studies . . . . .232–242, 259–260  
   channelization/rechannelization . . . . .202, 236–242  
   classical . . . . .199  
   completion of . . . . .234–236  
   defined . . . . .199  
   and emergence . . . . .200  
   and erosion . . . . .206, 232–234  
   evidence of . . . . .192, 203–204, 208  
   ice jam . . . . .203  
   International Boundary Rivers . . . . .204–205  
   islands . . . . .86  
   lakes . . . . .204  
   legal effect of . . . . .200–204  
   levee cutoff . . . . .203  
   point bar . . . . .202  
   and resurveys . . . . .205  
   types of . . . . .202–203  
   Yazoo . . . . .203

## B

Backswamp . . . . .200  
 Bancos . . . . .205  
 Bar, river . . . . .199  
 Basart Doctrine . . . . .268–271  
 Base lines . . . . .40, 42, 169  
 Bearing  
   accuracy requirements . . . . .37  
   allowable deviation . . . . .46–47  
   governing boundary . . . . .47  
   grid . . . . .35  
   line of constant bearing . . . . .29–30  
   line of constantly changing bearing . . . . .30  
   mean . . . . .28–30, 34  
 Bearing objects . . . . .122  
 Bearing trees . . . . .121–122, 126  
 Bed scour . . . . .198

Blaze . . . . .92, 118  
 Blocks, townsite . . . . .338–339  
 Bona fide rights . . . . .9  
   alienated lands . . . . .162–163  
   mining claims . . . . .370–372  
   resurveys . . . . .133, 155, 157–163  
   special surveys . . . . .334–335  
 Bottom lands . . . . .94  
 Boundaries. *See also* Township exteriors;  
   Water boundaries  
   grant . . . . .176–177  
   irregular . . . . .55–58, 126, 174  
   latitudinal . . . . .29, 44–47, 50–51  
   legal . . . . .3, 18  
   meridional . . . . .29, 43–44, 51  
   mineral lands leasing . . . . .345  
   mining claims . . . . .353  
   nonrectangular surveys . . . . .337  
   principles for . . . . .13  
   rivers as . . . . .186–187  
   unofficial . . . . .143  
 Braided streams . . . . .198, 201  
 Bureau of Land Management (BLM) . . . . .4–5, 8, 10–11  
   and Forest Service . . . . .25  
   and GLO . . . . .23–24  
   resurveys . . . . .131–132, 147–148  
   State Offices of . . . . .14–15  
 Bureau of Reclamation (BOR) . . . . .23, 334–335

## C

Cadastral survey. *See also* Survey . . . . .2, 29, 156–157  
 Cadastral surveyor  
   and legal issues . . . . .132  
   responsibilities of . . . . .2, 12, 76, 144–145, 352  
   resurveys . . . . .148  
 Cadastral Survey Program . . . . .11, 147  
 California . . . . .15, 22, 30, 90  
 Call, topographic . . . . .151–152  
 Cancelled survey . . . . .78, 139, 363  
 Cardinal equivalent . . . . .166  
 Cardinal square . . . . .32  
 Case decisions  
   *Adams v. Boston Wharf Company* . . . . .278–279  
   *Alabama v. Georgia* . . . . .82  
   *Alaska United Gold Mining*  
     *Co. v. Cincinnati-Alaska*  
       *Mining Co.* . . . . .271–272, 296, 366  
   *Algoma Lumber Co. v. Kruger* . . . . .62  
   *Apex & Extralateral Rights Issues*  
     *Raised by the Stillwater Mineral Patent* . . . . .365  
   *Argillite Ornamental Stone Co.* . . . . .354  
   *Aria v. United States* . . . . .89, 201

- Arkansas Sunk Lands* . . . . .262–264  
*Arkansas v. Tennessee* . . . . .201, 234–236, 256  
*Barclay v. Howell's Lessee* . . . . .247  
*Baxter v. Evett's Lessee* . . . . .247  
*Beaver v. United States* . . . . .243–245  
*Belligerent and Other Lode Mining Claims* . . . . .356–357  
*Benson Mining & Smelting Co. v. Alta Mining & Smelting Co.* . . . . .370  
*Bonelli Cattle Co. v. Arizona* . . . . .238–241  
*Borax Consolidated Ltd. v. Los Angeles* . . . . .207, 222  
*Borough of Ford City v. United States* . . . . .99–100  
*Brattain Contractors, Inc.* . . . . .361  
*Burt A. Wackerli* . . . . .219  
*California Coastal Commission v. Granite Rock Co.* . . . . .370–371  
*California ex. rel. State Lands Commission v. United States* . . . . .193  
*Chapman & Dewey Lumber Co. v. St. Francis Levee District* . . . . .264  
*Charles B. Reynolds, Jr., et al.* . . . . .366  
*Churchill v. Grundy* . . . . .247  
*Cissna v. Tennessee* . . . . .235  
*Commissioners of Land Office of State of Oklahoma v. United States* . . . . .249–251, 254–256  
*Cost of Official Survey of a Mining Claim* . . . . .362  
*County of St. Clair v. Lovington* . . . . .206, 245–248  
*Cox v. Hart* . . . . .286  
*Cragin v. Powell* . . . . .129, 131, 271, 296  
*Crooked Lake and Bear Lake* . . . . .267  
*Daniel Ball, The* . . . . .187–188  
*David A. Provinse* . . . . .345  
*DeBoer v. United States* . . . . .268–269  
*Del Monte Mining and Milling Co. v. Last Chance Mining and Milling Co.* . . . . .364  
*Dennis J. Kitts* . . . . .366  
*Dunlap v. Stetson* . . . . .206  
*Economy Light and Power Company v. United States* . . . . .188, 228, 230  
*Emerson v. Taylor* . . . . .272  
*Exxon Corp v. Bureau of Land Management* . . . . .253–254  
*French-Glenn Live Stock Co. v. Springer* . . . . .264  
*Georgia v. South Carolina* . . . . .261–262  
*Golden Sun Mining Co.* . . . . .354  
*Grand Rapids and Indiana Railroad Co. v. Butler* . . . . .252–253  
*Grant v. Pilgrim* . . . . .365  
*Gray v. Deluce* . . . . .277–278  
*Handly's Lessee v. Anthony* . . . . .247  
*Hardin v. Jordan* . . . . .252  
*Hardy Salt v. Southern Pacific* . . . . .230  
*Harrison v. Fite* . . . . .228  
*Hidden Treasure Mine* . . . . .355  
*Hidee Cold Mining Co.* . . . . .364  
*Holmes Placer* . . . . .366  
*Houston v. Thomas* . . . . .259–260  
*Howard v. Ingersoll* . . . . .97–99  
*Iris v. Town of Hingham* . . . . .223  
*Iron Silver Mining Co. v. Elgin Mining & Smelting Co.* . . . . .364  
*Jack K. Carter* . . . . .365  
*James Carretto and Other Lode Claims* . . . . .361  
*James L. Harden* . . . . .345  
*Jeems Bayou Fishing and Hunting Club v. United States* . . . . .264–267  
*John McClennen* . . . . .219  
*Johnston v. Jones* . . . . .210, 215, 222  
*Kaiser Aetna et al. v. United States* . . . . .188  
*Kirby v. Lewis* . . . . .285  
*Knight v. United States Land Association* . . . . .158  
*Koch v. United States* . . . . .253–254  
*Lane v. Darlington* . . . . .131  
*Lane v. United States* . . . . .81  
*Lara v. Secretary of the Interior* . . . . .357  
*Lee Wilson and Company v. United States* . . . . .262–264  
*Lessee of McCulloch v. Aten* . . . . .247  
*Lincoln Placer* . . . . .354  
*Longview Fibre Co.* . . . . .157  
*Louisiana v. Mississippi* . . . . .259–260  
*Madison v. Basart* . . . . .221, 268  
*Mason v. Cromwell* . . . . .285  
*Minnehaha Creek v. Corps of Engineers* . . . . .229–230  
*Minnesota Mining Co. v. National Mining Co.* . . . . .372  
*Mississippi v. Louisiana* . . . . .260  
*Montello, The* . . . . .187–188  
*Moss v. Ramey* . . . . .254  
*Mulry v. Norton* . . . . .259  
*Nebraska v. Iowa* . . . . .201–202, 207, 232–233, 235  
*Newsom v. Pryor's Lessee* . . . . .247  
*Niles v. Cedar Point Club* . . . . .264  
*Ogilvie v. Copeland* . . . . .296  
*Oklahoma v. Texas* . . . . .186, 188, 192, 215, 232, 254  
*Olive Wheeler* . . . . .251–253  
*Oregon ex. rel. State Land Board v. Corvallis Sand and Gravel Co.* . . . . .193, 238–241  
*Ownership of Submerged Lands* . . . . .366  
*Packer v. Bird* . . . . .228  
*Peterson v. Morton* . . . . .201, 241–242  
*Peterson v. Watt* . . . . .201, 241–242  
*Phillip Dephanger* . . . . .353

- Placer claim* . . . . .355
- P&M Petroleum Mgmt.* . . . . .345
- Pollard's Lessee v. Hagan* . . . . .88, 187
- Porter v. Sullivan* . . . . .276
- Port of Portland v. Island in the*  
*Columbia River* . . . . .260–261
- Preston's Heirs v. Bowmar* . . . . .247
- Puyallup Indian Tribe v. Port of Tacoma* . . . . .202
- Railroad Co. v. Schurmeier* . . . . .84, 249
- Robinson v. Forrest* . . . . .286
- Salt Wells Live Stock Co.* . . . . .157
- Sam K. Viersen, Jr.* . . . . .345
- San Francisco Savings Union, et al. v. Irwin* . . . . .89
- Sawyer v. Gray* . . . . .286
- Scott v. Lattig* . . . . .248–249, 252
- Security Land & Exploration Co. v. Burns* . . . . .264
- Shively v. Bowlby* . . . . .206
- Sinnott v. Jewett* . . . . .368
- Smallidge et al. v. Brown & Gilley* . . . . .273–275
- Smith v. United States* . . . . .268
- Snow Flake Fraction Placer* . . . . .357
- South Dakota v. Madill* . . . . .351
- Sparhawk v. Bullard* . . . . .277
- State of Louisiana* . . . . .264–267
- State of Montana* . . . . .191
- State of Oregon v. Bureau of Land*  
*Management* . . . . .372
- State v. Muncie Pulp Co.* . . . . .235
- St. Louis v. Rutz* . . . . .256–259
- Stone v. Boston Steel & Iron Company* . . . . .275–276
- Udall v. Oelschlaeger* . . . . .88
- Uhlhorn v. U.S. Gypsum Company* . . . . .236–238
- United States v. 11,993.32 Acres of Land*  
*in North Dakota* . . . . .268
- United States v. Alaska* . . . . .190
- United States v. Appalachian*  
*Power Co.* . . . . .188, 191, 226–228
- United States v. Byrne* . . . . .89, 201
- United States v. Chandler-Dunbar* . . . . .253
- United States v. Claridge* . . . . .100–102, 206
- United States v. Cowlshaw* . . . . .295
- United States v. Crow, Pope & Land*  
*Enterprises, Inc.* . . . . .226
- United States v. Curtner* . . . . .286
- United States v. Harrell* . . . . .103
- United States v. Hess* . . . . .194
- United States v. Holt State Bank* . . . . .191, 225–226
- United States v. Hurlburt* . . . . .295
- United States v. Hutchings* . . . . .249–251, 254
- United States v. Lara* . . . . .357
- United States v. Mission Rock Co.* . . . . .252
- United States v. Morrison* . . . . .286, 295
- United States v. Oregon* . . . . .86, 186, 193
- United States v. Reimann* . . . . .131, 157
- United States v. Ross* . . . . .228–229
- United States v. Smith* . . . . .361
- United States v. Swanson* . . . . .363
- United States v. Utah* . . . . .188, 230–232
- United States v. Walton* . . . . .269–270
- United States v. Washington* . . . . .207
- United States v. Webb* . . . . .353
- Ventura Coast Oil Co.* . . . . .365
- Veta Grande Lode* . . . . .354
- Wackerli v. Morton* . . . . .219
- Walker v. The Boston & Maine Railroad* . . . . .277
- Wallace v. Driver* . . . . .242
- Walter Bartol* . . . . .354
- Walton v. United States* . . . . .269–271
- Warner Assets Realization Corp.* . . . . .355
- Waskey v. Hammer* . . . . .352
- Western Aggregates, LLC* . . . . .191
- Wheeler v. United States* . . . . .251
- Whitaker v. McBride* . . . . .251
- Whitmore v. Brown & Gilley* . . . . .273–275
- Williams v. United States* . . . . .158
- Wilson v. Omaha Indian Tribe* . . . . .193
- Wittmayer v. United States* . . . . .268
- Wolff v. United States* . . . . .251–253
- Wonson v. Wonson* . . . . .278–282
- Wright vs. Roseberry* . . . . .89
- Zunamon v. United States* . . . . .102–103
- Certificate of survey . . . . .294
- Chain of title . . . . .2
- Chain unit . . . . .37
- Channelization . . . . .202, 236–242
- Chief Cadastral Surveyor . . . . .8, 11–12, 21, 285
- Chief Geographer . . . . .3, 18, 20
- Chute channels . . . . .199
- Claims. *See also* Mining claims  
 fraudulent or erroneous surveys . . . . .161–162  
 and good faith location rule . . . . .154–155  
 intersecting lines . . . . .58–59  
 lode . . . . .351, 355–357, 368  
 placer, . . . . .351, 353, 355–357, 365–366  
 and subdivision . . . . .66  
 tract segregation of . . . . .139–141, 321–328
- Clarke's Spheroid . . . . .34
- Closing corners . . . . .14, 169, 172–173
- Closure  
 apparent misclosure . . . . .31–32  
 error of . . . . .32, 50, 54–55, 91  
 limits of . . . . .50, 54–55, 61, 90–91, 344
- Collateral evidence . . . . .136, 148–150, 154–157, 160
- Colonial method of partition . . . . .210, 214
- Colonial States . . . . .5, 7, 188
- Colorado . . . . .15

- Commerce Clause . . . . .188, 191  
 Commissioner of the General Land Office  
   (GLO) . . . . .4, 21–22  
 Compass rule adjustment . . . . .176  
 Completion surveys . . . . .60–63, 214  
 Condemnation . . . . .159  
 Contract file . . . . .286, 295, 308  
 Control points . . . . .109, 121  
 Convergence, angle of . . . . .29  
 Convergency of meridians . . . . .31–33  
 Conversions . . . . .37–38  
 Conveyances. *See also* Patents . . . . .134  
   ANCSA . . . . .24  
   interim . . . . .76, 131  
   intersecting lines . . . . .59  
   and land description . . . . .7  
   navigable waters . . . . .188–189  
   and official plats . . . . .271  
   and protraction diagrams . . . . .76  
   and USIS surveys . . . . .333  
 Coordinate systems  
   geographic position . . . . .34–35  
   latitudes and departures . . . . .34  
   National Geodetic Survey (NGS) . . . . .34  
   State Plane Coordinate  
     Systems (SPCS) . . . . .35–36, 166  
 Corner accessories . . . . .107–108, 121–127, 148  
   bearing objects . . . . .122  
   bearing trees . . . . .121–122, 126  
   marking . . . . .124–127  
   memorials . . . . .122–123  
   pits . . . . .124  
   stone . . . . .123–124, 126  
 Corners. *See also* Lost corners; Meander corners;  
   Monumentation; Witness corners . . . . .13, 40, 42  
   angle points as . . . . .148, 171  
   closing . . . . .14, 169, 172–173  
   controlling weights . . . . .166, 178  
   defective . . . . .50–51  
   defined . . . . .148  
   elongated sections . . . . .114–115  
   existent . . . . .148–149, 165  
   extension and completion surveys . . . . .61–63  
   field note record of . . . . .293–294  
   fixed . . . . .21, 105  
   intermediate . . . . .117–118, 126  
   intersecting and terminating section lines . . . . .58–59  
   junior-senior . . . . .169–170  
   lines between . . . . .91–92  
   marking . . . . .109–121, 124–127  
   maximum/minimum  
     control . . . . .43, 58–59, 112, 120, 125, 293  
     mile . . . . .148  
   mineral surveys . . . . .356–357, 359, 368  
   obliterated . . . . .135–136, 149–150, 165  
   official . . . . .18  
   original . . . . .40, 50, 165  
   and protraction diagrams . . . . .76–79  
   rectangular limits . . . . .49  
   resurveys . . . . .61  
   senior-senior . . . . .169–171  
   sixteenth-section . . . . .14  
   special purpose . . . . .121, 148, 177  
   special survey . . . . .330, 332  
   standard . . . . .14, 42, 169  
   subdivision-of-section . . . . .64, 69–70, 74,  
     117, 126  
   symbols for . . . . .303  
   township exteriors . . . . .12, 43–46, 166–171  
   townsite . . . . .148  
   tract . . . . .148  
   true . . . . .14  
   unmonumented . . . . .148  
 Correction lines . . . . .14, 42, 169  
 Crossing closing corners . . . . .173  
 Cumulative error . . . . .55  
 Curvature . . . . .30–31
- ## D
- Datum . . . . .29  
 Defective corners . . . . .50–51  
 Deflection of the vertical . . . . .33  
 Department of the Interior . . . . .9–10  
 Department of Treasury . . . . .20  
 Departure . . . . .34  
 Dependent resurveys. *See also* Resurveys . . . . .129–130,  
   133–137  
   field notes . . . . .290, 292–293  
   and good faith location rule . . . . .155  
   mineral surveys . . . . .367–372  
   plats . . . . .320–321  
   points of control . . . . .156–157  
   special case conditions . . . . .159–162  
   special surveys . . . . .333–335  
   specimen field notes . . . . .411–450  
   townsites . . . . .338  
   water boundaries . . . . .183–184, 186, 212  
 Director of Bureau of Land  
   Management (BLM) . . . . .2, 5, 8, 10–11, 15, 17, 23  
 Disclaimer of interest . . . . .25  
 Distance measurement . . . . .27–28, 30–31  
 D.M.D. method of computation . . . . .300–301  
 Doctrine of Reemergence . . . . .208  
 Double meridian distance method . . . . .32  
 Double proportionate measurement . . . . .165–168, 171

**E**

- Economy Act of May 21, 1920 . . . . . 23
- Education Land Grant Act of
  - December 28, 2000 . . . . . 343
- Education Land Grant surveys . . . . . 343
- Elevation . . . . . 33
- Elongated sections . . . . . 66–68, 114–115, 142
- Emergence . . . . . 199–200
- Emergence by accretion . . . . . 207
- Erosion . . . . . 206–208, 316–317
  - and avulsion . . . . . 206, 232–234
  - and river meanders . . . . . 198–199
  - and submergence . . . . . 200
- Erroneous omitted lands . . . . . 219–221, 262–267, 317
- Erroneous surveys . . . . . 159–162
- Errors. *See also* Measurement
  - accumulated . . . . . 55
  - apparent misclosure . . . . . 31–32
  - and cardinal equivalent . . . . . 166
  - of closure . . . . . 32, 50, 54–55, 91
  - compass rule adjustment . . . . . 176
  - index correction for . . . . . 168, 178
  - standard line . . . . . 42
- Evidence
  - of avulsions . . . . . 192, 203–204, 208
  - collateral . . . . . 136, 148–150, 154–157, 160
  - corroborative . . . . . 149–151
  - direct . . . . . 150–154
  - and field notes . . . . . 285
  - good faith locations . . . . . 154–155
  - individual testimony . . . . . 150–151
  - international boundary monuments . . . . . 154
  - line trees . . . . . 152–153
  - local points of control . . . . . 156–157
  - meander corners . . . . . 153
  - original . . . . . 157
  - positive . . . . . 203–204, 208
  - relevant . . . . . 149
  - satisfactory local conditions . . . . . 155–156
  - scintilla of . . . . . 149
  - State boundary monuments . . . . . 153–154
  - substantial . . . . . 149
  - sufficient . . . . . 149
  - topographic calls . . . . . 151–152
  - types of . . . . . 149
  - witness corners . . . . . 152
  - witness points . . . . . 153
- Exchange surveys . . . . . 341–342
- Existent corners . . . . . 148–149, 165
- Extension of property line method . . . . . 210
- Extension surveys . . . . . 60–63
- Extralateral rights . . . . . 364–365

**F**

- Face, tunnel . . . . . 363
- Falling of line . . . . . 45, 47
- Farm units . . . . . 334–335
- Federal authority survey . . . . . 2, 29, 156–157
- Federal Geographic Data Committee (FGDC) . . . . . 11, 36
- Federal interest lands . . . . . 4–7
  - administration of . . . . . 5
  - defined . . . . . 4–5
  - islands and sandbars . . . . . 218
  - legal boundaries in . . . . . 3, 18
  - navigable/nonnavigable waters . . . . . 5, 186, 188–190, 192, 214–217
  - ownership of . . . . . 1, 4–5, 19
  - removal of improvements . . . . . 159
  - resurveys . . . . . 130–132, 139, 156
  - and State law . . . . . 3, 18, 153
  - swamp and overflowed lands . . . . . 7
  - water boundaries . . . . . 193–194, 206–209
- Federal Land Policy and Management
  - Act (FLPMA) of October 21, 1976 . . . . . 10, 24–25, 351
- Federal Mine Health and Safety Acts of 1969
  - and 1977 . . . . . 347
- Federal records . . . . . 24
- Federal Records Act of 1950 . . . . . 24
- Federal Water Pollution Control Act . . . . . 188
- Field notes. *See also* Records, survey . . . . . 93–96, 285–295
  - abbreviations . . . . . 290
  - as evidence . . . . . 285
  - field returns . . . . . 285
  - geographic positions . . . . . 35
  - headings and subheadings . . . . . 289
  - index diagram . . . . . 289
  - mineral surveys . . . . . 358–360
  - monumentation . . . . . 105–106, 292
  - notations and amendments . . . . . 295
  - order of writing . . . . . 290–292
  - placer claims . . . . . 357–358
  - and plats . . . . . 285–286
  - preparation . . . . . 286–287
  - reproduction and distribution of . . . . . 294
  - and restoration . . . . . 168
  - resurveys . . . . . 157, 290, 292–293
  - rules for . . . . . 12–13
  - specimen . . . . . 295
    - dependent resurveys . . . . . 411–450
    - mineral surveys . . . . . 451–472
    - original survey . . . . . 375–410
  - standardization of . . . . . 292–294
  - titles . . . . . 287–289
  - township . . . . . 286



townsite surveys . . . . .339–340  
 Filing, official. . . . .2, 26, 286, 295–296  
 Fish and Wildlife Service (FWS). . . . .23  
 Fixed corners . . . . .21, 105  
 Flood plain . . . . .200  
 Florida . . . . .16, 90, 181  
 Foot, U.S. Survey. . . . .28, 37  
 Foreign sovereign land. . . . .4, 19, 22  
 Forest Homestead Entry surveys . . . . .23  
 14(c) surveys . . . . .337, 340–341  
 Four-way proportion . . . . .166, 171  
 Fractional sections . . . . .13–14, 22, 66, 69–70, 186  
 Fragmentary surveys . . . . .315–318  
 Fraudulent surveys. . . . .159–162  
 French tracts. . . . .21  
 French units of area . . . . .37

## G

General Forest Exchange surveys . . . . .341–342  
 General Land Office (GLO). . . . .4, 8–10, 21–24, 333–334  
 General Mining Law of 1872. . . . .350  
 General Resurvey Act of March 3, 1909 . . . . .9, 18  
 Geodesic. . . . .29  
 Geodetic meridian . . . . .27–28, 33  
 Geodetic methods. *See also* Survey. . . . .29, 32  
 Geographic Coordinate Data Base  
 (GCDB). . . . .318–319, 346  
 Geographic position. . . . .34–35  
 Geological derivation. . . . .96  
 Geospatial data. . . . .36  
 Good faith location . . . . .133, 135, 154–155, 162  
 Governing lines . . . . .33, 43  
 Grant boundaries . . . . .176–177  
 Grazing lands . . . . .19  
 Great circle. . . . .30  
 Grid bearing . . . . .35  
 Grid coordinate systems. . . . .35  
 Grid distance . . . . .28, 35  
 Ground distance . . . . .28, 32, 35  
 Group file . . . . .286, 295, 308, 310, 318  
 Guide meridians. . . . .39  
 auxiliary . . . . .43  
 irregular boundaries . . . . .55–58  
 Gunter’s link chain. . . . .165

## H

Hack. . . . .92  
 Half-mile posts. . . . .181  
 Hardrock Mining Claim Maintenance  
 Fee Act of 1993. . . . .351  
 Hawaii . . . . .17

## I

Idaho . . . . .16  
 Illinois . . . . .16, 90  
 Improved lands. . . . .154–155, 160–161  
 mineral surveys . . . . .360–362  
 removal of improvements. . . . .158–159  
 Independent resurveys . . . . .130, 133–134, 143  
 bona fide rights . . . . .162–163  
 field notes . . . . .292  
 new section lines . . . . .141–143  
 outboundaries . . . . .138–139  
 plats . . . . .321–328  
 tract segregation . . . . .137–142  
 Index correction . . . . .168, 178  
 Indiana . . . . .16, 90  
 Indian lands . . . . .5, 9, 22–23, 90, 190–191  
 allotment surveys . . . . .330–334, 341  
 boundaries of . . . . .193  
 Indian Service surveys . . . . .333–334  
 reservation surveys. . . . .330  
 Informative traverses . . . . .184, 194  
 Initial points . . . . .40  
 Inland waters . . . . .184–185  
 Interagency Cadastral Coordination  
 Council (ICCC). . . . .11  
 Interim conveyances . . . . .76, 131  
 Interior Board of Land Appeals (IBLA).  
*See also* Case decisions. . . . .10–11  
 Intermediate corners. . . . .117–118, 126  
 International boundary monuments . . . . .154  
 International Boundary Rivers. . . . .204–205  
 International Foot. . . . .37  
 International System of Units (SI) . . . . .37  
 Iowa . . . . .16, 90  
 Irregular boundaries . . . . .55–58, 126, 174  
 Irregular sections . . . . .62–63  
 Irregular townships . . . . .55–57, 59–60  
 Island Rule . . . . .218, 254–262  
 Islands . . . . .86–88  
 avulsion . . . . .86  
 case studies. . . . .248–262, 260–261  
 partition lines . . . . .214–215  
 unsurveyed . . . . .22, 24–25, 87, 218, 251–254  
 Isolated Tract Act of February 26, 1895 . . . . .22

## J

Junior-senior corners . . . . .169–170

## K

Kansas . . . . .16

**L**

- Lakes . . . . .83–85, 184, 186–187, 193
  - avulsive changes to . . . . .204
  - case studies . . . . .262–267
  - navigability of . . . . .225–226, 229–230
  - relicted beds of . . . . .212–214
- Lambert projection . . . . .35
- Land
  - beneath navigable waters . . . . .20, 189–191
  - classifications . . . . .5, 19
  - descriptions . . . . .4
  - status . . . . .19, 130
- Land Ordinance of May 20, 1785 . . . . .1, 7, 18, 20, 27
- Laplace correction . . . . .33
- Latitude, circles of . . . . .29
- Latitudinal boundaries . . . . .44–45, 50–51
- Latitudinal difference . . . . .34
- Latitudinal section lines . . . . .54–55
- Leasing, mineral lands . . . . .345–347
- Legal acres . . . . .21
- Legal rulings. *See* Case decisions
- Legal subdivision . . . . .8, 21, 47, 138, 320
- Levee, natural . . . . .200
- Limits
  - of closure . . . . .50, 54–55, 61, 90–91, 344
  - rectangular . . . . .48–50, 55, 91
- Line of constant bearing . . . . .29–30
- Line of mean high tide (MHT). . . . .81–88, 222–223
- Line of sight . . . . .30, 34
- Lines. *See* Section lines
- Line trees . . . . .92, 121, 127, 152–153
- Link unit . . . . .37
- Litter examination . . . . .83
- Local surveys. *See also* Resurveys. . . . .62
  - bona fide rights . . . . .157
  - defined . . . . .2, 129
  - measurements . . . . .35–36
  - monumentation . . . . .154, 156
  - points of control . . . . .156–157
  - and protraction diagrams . . . . .81
  - subdivision by . . . . .73–74
  - and supplemental plats . . . . .310
- Location, good faith . . . . .133, 135, 154–155, 162
- Location certificates . . . . .362
- Location monuments . . . . .108, 121, 127, 359
- Location surveys . . . . .352–353
- Lode claims . . . . .351, 355–357, 368
- Lode Law of 1866 . . . . .350
- Longitudinal difference . . . . .34
- Long lake method . . . . .213
- Lost corners. *See also* Restoration of
  - lost corners . . . . .14, 40, 130, 136
  - defined . . . . .165
  - meander . . . . .171–172
  - mining claims . . . . .368
  - and witness corners . . . . .152
- Lots
  - defined . . . . .329
  - and disposals record . . . . .329–330
  - Indian allotment surveys . . . . .330–334
  - legal subdivisions . . . . .47, 366
  - numbering . . . . .65–68, 297, 309, 330
  - resurveys . . . . .142, 323–324
  - townsite . . . . .339
- Louisiana . . . . .16, 90
- Loxodromes . . . . .29

**M**

- Maine case studies . . . . .272–275
- Manual of Surveying Instructions . . . . .1–4
  - development of . . . . .3–4, 18
  - and PLSS . . . . .7
  - supplements . . . . .4, 19, 145
- Massachusetts case studies . . . . .275–282
- Massachusetts Ordinance of 1641-1647 . . . . .223, 272
- Materials Act of 1927. . . . .350
- Maximum control corners . . . . .112, 120, 125
- Mean bearing . . . . .28–30, 34
- Meander corners. . . . .40–43, 112
  - auxiliary . . . . .83–85, 87–88, 117, 120, 125–126
  - as evidence . . . . .153
  - lost . . . . .171–172
  - partition lines . . . . .210–212
  - special . . . . .83, 85, 87–88, 115–116, 120, 125–126
  - witness corner meander corner (WCMC) . . . . .184
- Meander lines. . . . .81–82, 84–85, 88
  - angle points of . . . . .174–175, 185–186
  - erroneously omitted lands . . . . .219–220
  - lakes . . . . .187
  - land outside . . . . .221, 269–271
  - mineral lands leasing . . . . .345–346
  - mining claims and millsites . . . . .366–367
  - and ownership . . . . .81, 89, 183, 221
  - resurveys . . . . .184–185
- Meandering. *See also* Navigable waters;
  - Water boundaries . . . . .81–88, 183–186
  - agricultural test . . . . .83
  - of alluvial rivers . . . . .197
  - angle points . . . . .84
  - islands and sandbars . . . . .86–87, 218
  - lakes . . . . .83–85
  - line of mean high tide (MHT) . . . . .81–88
  - litter examination . . . . .83
  - nonnavigable water bodies . . . . .186–187

- ordinary high water mark (OHWM) . . . . .81–88, 97–103, 196
- and partition lines . . . . .209–217
- and protracted blocks . . . . .77
- remeandering . . . . .184, 209, 218
- rivers and tidewater . . . . .83, 85, 87–88
- salient point method . . . . .196
- soils examination . . . . .83
- and subdivision . . . . .66
- survey record and field notes . . . . .84
- swamp and overflowed lands . . . . .87, 89–90
- vegetation examination . . . . .82–83, 87–88, 90, 98–100, 102–103
- Mean high tide (MHT) . . . . .81–88, 222–223
- Measurement. *See also* Errors; Survey methods
  - accumulated error . . . . .55
  - accuracy . . . . .36
  - and coordinate systems . . . . .35–36
  - datum . . . . .29
  - direct/indirect . . . . .28
  - direction . . . . .27–28
  - distance . . . . .27–28, 30–31, 37–38
  - and elevation . . . . .33
  - excess or deficiency in . . . . .12, 43–44, 166, 174
  - extension and completion surveys . . . . .61
  - instruments . . . . .28
  - method of proportionate measurement . . . . .152, 165–174, 178
  - rectangular limits . . . . .49
  - resurveys . . . . .137
  - townsite surveys . . . . .339
  - verification of . . . . .42
- Medial lines . . . . .194–197, 367
- Median lines . . . . .194–197
- Memorials . . . . .122–123
- Meridian
  - angle of convergence of . . . . .29
  - astronomic . . . . .27–28, 33, 35
  - convergency . . . . .31–33
  - geodetic . . . . .27–28, 33
  - guide . . . . .39, 43, 55–58
  - principal . . . . .39–42
  - reference . . . . .29, 354
  - true . . . . .27–29, 354
- Meridional boundaries . . . . .43–44, 51
- Meridional section lines . . . . .14, 33, 54–55
- Metes-and-bounds surveys . . . . .19, 158, 335–337
- Metric conversions . . . . .37
- Mexican units of distance . . . . .37–38
- Michigan . . . . .16, 90
- Mile corners . . . . .148
- Military reservations . . . . .23
- Millsite Act of March 18, 1960 . . . . .350
- Millsites . . . . .351, 353, 355–356, 362, 365–367
- Mineral lands
  - case studies . . . . .271–272
  - defined . . . . .5, 19
  - resurveys . . . . .367–372
  - and water boundaries . . . . .222, 271–272
- Mineral Leasing Act of 1920 . . . . .345, 347, 350
- Mineral Leasing Act surveys . . . . .345–347
- Mineral surveys . . . . .4, 9, 350–372
  - amended orders . . . . .362
  - cancellation of . . . . .363
  - conflicts . . . . .358–359, 368–371
  - corners . . . . .356–357, 359, 368
  - dependent resurveys . . . . .367–372
  - extralateral rights . . . . .364–365
  - field notes . . . . .358–360
  - gaps and overlaps . . . . .371–372
  - improvements . . . . .360–362
  - legal subdivision . . . . .365–366
  - location survey . . . . .352–353
  - lode lines and end lines . . . . .355–356
  - method and order of procedure . . . . .356–358
  - mineral monuments . . . . .108–109, 359, 370
  - mineral patent application survey . . . . .353–355
  - mining law . . . . .350–351
  - plats . . . . .297, 313–314, 360
  - segregation surveys . . . . .314–315, 348–349, 351
  - sequential grants . . . . .367
  - specimen field notes . . . . .451–472
  - subsurface estate . . . . .222
  - topography . . . . .359
  - tunnel sites . . . . .363
- Mine surveys . . . . .347–348
- Minimum control corners . . . . .43, 58–59, 112, 120, 125, 293
- Mining claims. *See also* Mineral surveys
  - extralateral rights . . . . .364–365
  - improvements . . . . .360–362
  - laws governing . . . . .350–351
  - lode claims . . . . .351, 355–357, 368
  - and patents . . . . .351, 360–362, 369–371
  - placer claims . . . . .351, 353, 355–357, 365–366
  - plats . . . . .297
  - riparian rights . . . . .366–367
  - segregation surveys . . . . .348–349
  - title . . . . .368–371
  - types of . . . . .351–352
  - valid . . . . .352–353
- Mining Laws of 1866, 1870, and 1872 . . . . .19, 350, 352, 367
- Minnesota . . . . .16, 90
- Misclosure . . . . .31–32
- Mississippi . . . . .16

Missouri . . . . .16, 90  
 Montana . . . . .16  
 Monumentation . . . . .46, 105–127  
   amended . . . . .50  
   ANCSA . . . . .24  
   angle points . . . . .84, 108, 117, 126, 139, 141, 186  
   construction of . . . . .106–107  
   corner accessories . . . . .107–108, 121–127, 148  
   defined . . . . .148  
   destruction of . . . . .9  
   field notes . . . . .105–106, 292  
   international . . . . .154  
   intersecting section lines . . . . .59  
   legal significance of . . . . .105  
   local . . . . .154, 156  
   location monuments . . . . .108, 121, 127, 359  
   marking . . . . .109–121  
   metal . . . . .23  
   mineral monuments . . . . .108–109, 359, 370  
   mineral segregation surveys . . . . .348  
   partition lines . . . . .211–212  
   reference . . . . .107–108, 120–121, 126  
   restoration of lost corners . . . . .170, 172–173  
   resurveys . . . . .136–137, 139, 162  
   small tract surveys . . . . .344  
   special purpose . . . . .105, 107–109, 117,  
     120–121, 126–127  
   State boundary . . . . .153–154  
   and subdivision . . . . .105  
   townsite . . . . .339  
   tree monuments . . . . .118–122  
   types of . . . . .106  
   witness corners . . . . .84, 105, 107, 120, 126

## N

Names of topographic features . . . . .307  
 National Forest Homestead Entry and Allotment  
   Surveys . . . . .23, 341  
 National Forest Lands . . . . .23–24, 26  
 National Forest System Lands Small Tracts Act of  
   January 12, 1983 . . . . .25  
 National Forest System Lands small  
   tracts surveys . . . . .342–343  
 National Forest Townsite Act of July 31, 1958 . . . . .343  
 National Forest townsite surveys . . . . .343  
 National Geodetic Survey (NGS) . . . . .34  
 National Park Service (NPS) . . . . .23  
 National Spatial Data Infrastructure (NSDI) . . . . .11, 36  
 National Spatial Reference System (NSRS) . . . . .346  
 Natural levees . . . . .200  
 Navigability . . . . .186–193  
   legal definition of . . . . .187–188

  navigability investigation . . . . .191–193  
   and ownership . . . . .188–189  
   State law . . . . .191–192, 215  
 Navigable waters.  
   *See also* Nonnavigable waters . . . . .5, 7–8, 20, 24  
   Alaska . . . . .25–26  
   case studies . . . . .225–231  
   Federal control of . . . . .186, 188–190, 192, 193  
   lakes . . . . .225–226, 229–230  
   lands beneath . . . . .20, 189–191  
   mining claims and millsites . . . . .366–367  
   partition lines on . . . . .209–212  
   rivers . . . . .226–228, 230–232  
 Nebraska . . . . .16  
 Nevada . . . . .16, 30  
 New Mexico . . . . .16  
 Non-Federal lands  
   defined . . . . .19  
   legal boundaries in . . . . .3  
 Nonnavigable waters . . . . .186–187, 208  
   lakes . . . . .193  
   mining claims and millsites . . . . .367  
   rivers . . . . .184, 214–217,  
     228–229, 230–232  
 Non-public land States . . . . .17  
 Nonrectangular surveys . . . . .158, 335–337, 341, 357  
 North American Datum of 1983  
   (NAD 83) . . . . .29, 33, 346  
 North Dakota . . . . .16  
 Northwest Territory Ordinance of July 13, 1787 . . . . .20  
 Numbering  
   lots . . . . .65–68, 297, 309, 330  
   townships . . . . .12, 20  
   tracts . . . . .142, 163, 329

## O

Obliterated corners . . . . .135–136, 149–150, 165  
 Office of Hearings and Appeals (OHA) . . . . .10  
 Official corners . . . . .18  
 Official filing . . . . .2, 26, 286, 295–296  
 Official resurvey . . . . .148, 157–158  
 Official surveys . . . . .2, 29, 156–157, 286, 296  
 Offshore islands and rocks . . . . .88  
 Ohio . . . . .16, 20, 90  
 Oklahoma . . . . .16–17  
 Omitted lands . . . . .25, 184, 219–221  
 One-eight corners . . . . .332  
 One-point control . . . . .136, 178  
 Opposite banks delimitations . . . . .194–197  
 Ordinances  
   1641-1647  
   Massachusetts Ordinance . . . . .223, 272

May 20, 1785  
 Land Ordinance . . . . . 1, 7, 18, 20, 27  
 July 13, 1787  
 Northwest Territory Ordinance . . . . . 20  
 Ordinary high water mark (OHWM) . . . . . 81–88, 196  
 case studies . . . . . 97–103  
 Oregon . . . . . 17, 90  
 Original corners . . . . . 40, 50, 165  
 Original surveys. *See also* Rectangular surveys,  
 system of; Resurveys . . . . . 15, 17, 27, 39–40  
 cancellation of . . . . . 139  
 and local surveys . . . . . 129  
 and resurveys . . . . . 129–130, 144, 155–157  
 specimen field notes . . . . . 375–410  
 Overflowed lands . . . . . 7, 22, 87, 89–90  
 “Overflow lands” . . . . . 89  
 Ownership. *See also* Federal interest lands . . . . . 64  
 absentee . . . . . 161  
 and accretions . . . . . 205–207  
 and avulsions . . . . . 201, 204, 206  
 and erroneous location . . . . . 158–159  
 islands . . . . . 215, 218, 248–251, 254–256, 260–261  
 and local surveys . . . . . 129  
 and meander lines . . . . . 81, 89, 183, 221  
 mining claims . . . . . 368–371  
 navigable/nonnavigable waters . . . . . 186, 188–189  
 and relictions . . . . . 214  
 and resurveys . . . . . 130–132

## P

Parallelism doctrine . . . . . 365  
 Parallel lines  
 of PLSS . . . . . 33  
 substantially . . . . . 365  
 Parallel of latitude . . . . . 29–30  
 Parcels . . . . . 329  
 Partially surveyed sections . . . . . 70–73, 315  
 Partition lines . . . . . 209–217  
 case studies . . . . . 272–282  
 land outside meanders . . . . . 221–222  
 on navigable waters . . . . . 209–212  
 nonnavigable rivers . . . . . 214–217  
 relicted beds of lakes . . . . . 212–214  
 Patents. *See also* Conveyances . . . . . 1, 20  
 and avulsions . . . . . 201  
 and interim conveyances . . . . . 76  
 mineral patent application survey . . . . . 353–355  
 and mining claims . . . . . 351, 360–362, 369–371  
 navigable waters . . . . . 189  
 and non-Federal improvements . . . . . 158  
 and official plats . . . . . 272  
 and survey rules . . . . . 129

Perch unit . . . . . 37  
 Perpendicular method of partition . . . . . 210  
 Photogrammetry . . . . . 339  
 Pits . . . . . 124  
 Placer claims . . . . . 351, 353, 355–357, 365–366  
 Placer Law of 1870 . . . . . 350  
 Plane survey . . . . . 31–32, 35–36  
 Plan of Survey Coordinates (POSC) . . . . . 77–79  
 Plats . . . . . 295–328  
 amended protraction diagrams . . . . . 79  
 angle points . . . . . 108  
 areas on . . . . . 299–301, 320–321, 327  
 as base drawings . . . . . 297  
 certifications . . . . . 307–308  
 and conveyances . . . . . 271  
 copies of . . . . . 12  
 corner symbols . . . . . 303  
 defined . . . . . 295  
 dependent resurveys . . . . . 320–321  
 drafting . . . . . 64–65  
 erroneously omitted lands . . . . . 220  
 extension and completion surveys . . . . . 62–63  
 farm units . . . . . 334–335  
 and field notes . . . . . 285–286  
 fragmentary surveys . . . . . 315–318  
 hierarchy of evidence . . . . . 20–21  
 independent resurveys . . . . . 321–328  
 index . . . . . 323–324, 327–328  
 inking . . . . . 301–303  
 legal significance of . . . . . 296  
 lettering . . . . . 301–306  
 and lotting . . . . . 297  
 memorandum . . . . . 307  
 mineral segregation surveys . . . . . 297, 314–315  
 mineral surveys . . . . . 297, 313–314, 359–360  
 mine survey . . . . . 347  
 notations, amendments,  
 and corrections . . . . . 308–309  
 and patents . . . . . 272  
 protraction diagrams . . . . . 318–320  
 reproduction and distribution of . . . . . 308  
 resurveys . . . . . 320–328  
 scales . . . . . 298, 307  
 segregated tracts . . . . . 309, 321–328  
 sketch . . . . . 95–96  
 specimen . . . . . 296–297, 473, 475  
 subdivisions on . . . . . 298–299  
 supplemental . . . . . 309–313, 327, 344  
 three-plat system . . . . . 8  
 titles and subtitles . . . . . 307  
 topographic features . . . . . 306–308  
 township . . . . . 298–299  
 townsite . . . . . 340



witness corners . . . . .107

Point bars . . . . .199

Point of record . . . . .29

Pole unit . . . . .37

Possessory rights . . . . .370

Posts . . . . .92, 105–106, 181, 340–341

Principal Clerk of the Surveys . . . . .4, 22

Principal meridians . . . . .39–42

Private land. *See also* Alienated lands . . . . .5, 10–11, 19, 22

Projections . . . . .35

Property Clause . . . . .188, 191, 231

Proportionate acreage method . . . . .210

Proportionate measurement . . . . .152, 165–174, 178

Proportionate medial line method . . . . .213–214

Proportionate shoreline method . . . . .210

Protraction

- extension and completion surveys . . . . .60–61
- subdivision by . . . . .64–66
- water boundaries . . . . .186

Protraction diagrams . . . . .39, 42, 45, 50

- Alaska . . . . .25
- amended . . . . .76–81
- control positions . . . . .80
- and conveyances . . . . .76
- corner positions in . . . . .76–79
- partially surveyed sections . . . . .72
- plats of . . . . .318–320
- protracted blocks . . . . .77–78, 80–81, 88, 118, 126
- specimen plat . . . . .475
- water boundaries . . . . .224

Public domain lands . . . . .4–5, 8n, 11, 19

Public Land Administration Act of July 14, 1960 . . . . .24

Public lands

- defined . . . . .4–5, 8n, 19, 24
- inventory of . . . . .24
- location of surveys . . . . .15
- small tract surveys . . . . .343–345

Public land States . . . . .1, 5, 15–17

Public Land Survey System (PLSS).

- See also* Rectangular surveys, system of;
- Survey methods . . . . .3, 7, 129
- parallel lines of . . . . .33
- PLSS datum . . . . .28–29, 36–37
- rectangular/orthogonal plans . . . . .27, 29
- rules of . . . . .12–14
- special surveys . . . . .335
- and State Plane Coordinate Systems (SPCS) . . . . .35

## Q

Quarter-quarter-quarter sections . . . . .39, 113

Quarter-quarter sections . . . . .39

marking corners . . . . .113–114, 125

resurveys . . . . .141–142, 161

subdivision . . . . .13, 21–22, 69

Quarter sections

- area of . . . . .21
- marking corners . . . . .112–113, 119–120, 125
- restoration of lost corners . . . . .171, 173, 181
- resurveys . . . . .143
- subdivision . . . . .13, 69

Quiet Title Act of 1972 . . . . .132, 155

## R

Range lines . . . . .14

Reappearance . . . . .200

Rechannelization . . . . .202

Reclamation Act of June 17, 1902 . . . . .334–335

Reclamation projects . . . . .23

Reclamation Service (RS) . . . . .334–335

Records, survey. *See also* Field notes . . . . .93–96

- access to . . . . .22
- disposals . . . . .329–330
- Federal . . . . .24
- field data . . . . .285–286
- location of . . . . .18, 22
- mixing . . . . .178
- original . . . . .27
- resurveys . . . . .130, 136–137
- special instructions . . . . .283–285
- township . . . . .55, 58
- transcribed . . . . .165–166

Rectangular limits . . . . .48–50, 55, 91

Rectangular surveys, system of.

- See also* Public Land Survey System (PLSS);
- Survey methods . . . . .1, 19, 39–95
- aliquot parts in . . . . .47–48
- and coordinate systems . . . . .34
- departures from . . . . .21–22
- extension and completion surveys . . . . .60–63
- history . . . . .39
- legal requirements . . . . .39–40
- limits of closure . . . . .50, 54–55, 61, 90–91
- lines of constant bearing . . . . .30
- and local surveys . . . . .62
- marking lines . . . . .91–92
- meandering . . . . .81–88
- overview . . . . .39–40
- protraction diagrams . . . . .42, 45, 50, 72, 76–81
- subdivision . . . . .39–40, 64–75
- survey record and field notes . . . . .93–96
- swamp and overflowed lands . . . . .89–90
- townships . . . . .43–60
- and unsurveyed land . . . . .42

- Reemergence . . . . .200, 208  
Reference meridians . . . . .29, 354  
Reference monuments . . . . .107–108, 120–121, 126  
Regular sections . . . . .47–49, 50  
    area of . . . . .32  
    center lines of . . . . .14  
    extension and completion surveys . . . . .62  
Regular townships . . . . .54–55  
Regulation posts . . . . .105–106  
Reliction . . . . .199, 205–209, 212–214  
Reliction surveys . . . . .208–209, 212–214  
Remeandering . . . . .184, 209, 218  
Remote sensing . . . . .88  
Removal of improvements . . . . .158–159  
Reservations . . . . .330  
Restoration of lost corners . . . . .165–181  
    cardinal equivalent . . . . .166  
    closing corners . . . . .169, 172–173  
    controlling weights . . . . .166, 178  
    grant boundaries . . . . .176–177  
    hiatus or overlap . . . . .170–171  
    index correction . . . . .168, 178  
    irregular boundaries . . . . .174  
    junior-senior corners . . . . .169–170  
    meander lines . . . . .174–175  
    one-point control . . . . .178  
    precedence . . . . .166  
    proportionate measurement . . . . .165–174  
    quarter sections . . . . .171, 173, 181  
    section corners . . . . .168  
    senior-senior corners . . . . .169–171  
    standard corners . . . . .169  
    township corners . . . . .166–171  
    two- and three-point control . . . . .168  
Restricted land . . . . .26  
Resurveys. *See also* Dependent resurveys;  
    Evidence; Independent resurveys;  
    Restoration of lost corners;  
    Water boundaries . . . . .9–10, 18, 50, 61, 129–281  
    angle points . . . . .139, 141  
    and avulsions . . . . .205  
    bona fide rights . . . . .133, 155, 157–163  
    and boundary stability . . . . .147  
    collateral evidence . . . . .136, 148–150, 154–157, 160  
    and court jurisdiction . . . . .131–133, 136, 138, 148  
    direct evidence . . . . .150–154  
    existent corners . . . . .148–149  
    field examination . . . . .134–135, 141  
    field notes . . . . .157, 290, 292–293  
    meander lines . . . . .184–185  
    mineral lands . . . . .367–372  
    monumentation . . . . .136–137, 139, 162  
    obliterated corners . . . . .149–150  
    official . . . . .148, 157–158  
    one-point control . . . . .136  
    and original surveys . . . . .129–130, 144, 155–157  
    and ownership . . . . .130–131  
    plats . . . . .320–328  
    purpose of . . . . .131  
    records of . . . . .130, 136–137  
    retracements . . . . .130, 135, 165  
    section lines . . . . .137, 139, 141–144  
    special cases . . . . .143  
    State boundaries . . . . .153  
    subdivision . . . . .139, 141–142  
    township exteriors . . . . .50, 139, 142  
    true lines . . . . .137  
Retracement. *See also* Resurveys . . . . .130, 135, 165  
Rhumb line . . . . .29, 34  
Rights-of-way . . . . .25  
Riparian boundaries. *See* Meandering;  
    Water boundaries  
Riparian rights. *See also* Navigable waters . . . . .345,  
    366–367  
Riverfront tracts . . . . .21  
Rivers. *See also* Avulsion; Navigable waters . . . . .85,  
    186–187  
    acquired lands . . . . .223  
    alluvial . . . . .197–200, 206  
    flood stage . . . . .200  
    International Boundary Rivers . . . . .204–205  
    navigability of . . . . .226–228, 230–232  
    nonnavigable . . . . .184, 214–217, 228–229, 230–232  
Rod unit . . . . .37  
Round lake method . . . . .213  
Rule of decision . . . . .194
- ## S
- Sandbars . . . . .86, 218  
Sea level distance . . . . .28, 32, 35  
Secretary of Agriculture . . . . .26  
Secretary of the Interior . . . . .9–11, 22, 24, 131  
Secretary of the Treasury . . . . .20, 22, 131  
Sectional correction lines . . . . .55–58  
Sectional guide meridians . . . . .55–58  
Section lines  
    fixed . . . . .21  
    intersecting and terminating . . . . .58–59, 141, 162  
    latitudinal . . . . .54–55  
    marking . . . . .12, 91–92  
    and meanderable bodies of water . . . . .66  
    meridional . . . . .14, 33, 54–55  
    as offsets . . . . .45–46  
    protracted . . . . .76  
    resurveys . . . . .137, 139, 141–144

- Sections. *See also* Quarter-quarter sections;  
 Quarter sections; Subdivision . . . . . 39–40  
   elongated . . . . . 66–68, 114–115, 142  
   fractional. . . . . 13–14, 22, 66, 69–70, 186  
   irregular . . . . . 62–63  
   legal center of . . . . . 69  
   marking corners . . . . . 111–118, 124–126  
   outlying areas protracted as surveyed . . . . 60–64,  
     69–70, 315–316  
   partially surveyed . . . . . 70–73, 315  
   quarter-quarter-quarter . . . . . 39, 113  
   regular, . . . . . 14, 32, 47–50, 62  
   restoring lost corners, . . . . . 168  
 Segregation, . . . . . 137–142, 162–163  
   mineral surveys, . . . . . 314–315, 348–349, 351  
   plats . . . . . 309, 321–328  
 Segregation surveys . . . . . 341–343  
 Senior-senior corners . . . . . 169–171  
 Shore space . . . . . 83, 223  
 Sight trees . . . . . 92, 152  
 Single proportionate measurement . . . . . 168–174  
 SI units . . . . . 37  
 Sixteenth sections. *See* Quarter-quarter sections  
 Sketch plats . . . . . 95–96  
 Small circle . . . . . 29  
 Small tracts surveys . . . . . 342–345  
 Soil classification . . . . . 83, 96  
 Source of law determination . . . . . 3, 193–194  
 South Dakota . . . . . 17  
 Spanish units of distance . . . . . 37–38  
 Special case dependent resurveys . . . . . 159–162  
 Special instructions . . . . . 283–285  
 Special meander corners (SMC) . . . . . 83, 85, 87–88  
   corner accessories. . . . . 125–126  
   marking. . . . . 115–116, 120  
 Special purpose corners . . . . . 121, 148, 177  
 Special purpose monuments . . . . . 105, 107–109  
   accessories to . . . . . 126–127  
   marks on . . . . . 120–121  
 Special surveys . . . . . 329–349  
   corners . . . . . 330, 332  
   Education Land Grant surveys . . . . . 343  
   14(c) surveys . . . . . 337, 340–341  
   General Forest Exchange surveys . . . . . 341–342  
   Indian allotment surveys . . . . . 330–334  
   Mineral Leasing Act surveys . . . . . 345–347  
   mineral segregation surveys . . . . . 348–349  
   mine surveys . . . . . 347–348  
   National Forest Homestead Entry and  
     Allotment Surveys . . . . . 341  
   National Forest System Lands small  
     tracts surveys . . . . . 342–343  
   National Forest Townsite surveys, . . . . . 343  
     nonrectangular surveys . . . . . 335–337  
     public lands small tract surveys . . . . . 343–345  
     statutory method of subdivision . . . . . 330  
     subdivision . . . . . 329–334  
     three-mile method of subdivision . . . . . 332–333  
     townsite surveys . . . . . 337–340  
 Specimen field notes  
   dependent resurveys . . . . . 411–450  
   mineral surveys . . . . . 451–472  
   original survey . . . . . 375–410  
 Staking . . . . . 340–341  
 Standard corners. . . . . 14, 42, 169  
 Standard lines . . . . . 42  
 Standard parallels . . . . . 14, 42–43, 169  
 State boundary monuments . . . . . 153–154  
 State law . . . . . 3  
   avulsions . . . . . 204  
   mining . . . . . 351  
   navigable/nonnavigable waters . . . . . 191–192, 215  
   property boundaries . . . . . 156  
   swamp and overflowed lands . . . . . 7, 89–90  
   water boundaries . . . . . 189–190, 193–194,  
     206–209, 218  
 State Plane Coordinate Systems (SPCS) . . . . . 35–36, 166  
 Station trees . . . . . 92, 152  
 Statistical analysis . . . . . 36  
 Stone mounds . . . . . 123–124, 126  
 Straight line . . . . . 29  
 Subdivision . . . . . 1, 39–40, 64–75  
   extension and completion surveys . . . . . 62  
   fractional sections . . . . . 66  
   islands . . . . . 87  
   legal . . . . . 8, 21, 47, 138, 320  
   local . . . . . 73–74  
   mineral surveys . . . . . 365–366  
   and monumentation . . . . . 105  
   PLSS . . . . . 12  
   by protraction . . . . . 64–66  
   resurveys . . . . . 139, 141–142  
   segregated tracts . . . . . 323–324  
   small tract surveys . . . . . 344  
   special surveys . . . . . 329–334  
   by survey . . . . . 68–73  
   township . . . . . 12, 14, 20, 54–59, 63  
   water boundaries . . . . . 185  
 Subdivision-of-section corners . . . . . 64, 69–70, 74,  
     117, 126  
 Submerged Lands Act of 1953 . . . . . 24, 88, 189–191  
 Submergence . . . . . 199–200  
 Subsurface estate . . . . . 207, 222  
 Superseded surveys. *See* Independent resurveys  
 Supplemental plats . . . . . 309–313, 327, 344  
   specimen plat . . . . . 473

- Surface Mining Control and Reclamation Act  
of 1977 . . . . .347
- Surface Resources Act of 1955 . . . . .350
- Survey. *See also* Local surveys; Mineral surveys;  
Original surveys; Resurveys; Special surveys
- accretion . . . . .208–212
  - administration laws . . . . .7–10, 20–26
  - administrative . . . . .2, 157, 333–334
  - airborne . . . . .25
  - allotment . . . . .330–334
  - amended . . . . .362–363
  - cadastral . . . . .2, 29, 156–157
  - cancelled . . . . .78, 139, 363
  - certificate of . . . . .294
  - completion . . . . .60–63, 214
  - contract/direct . . . . .9–10
  - defined . . . . .2
  - erroneous . . . . .159–162
  - exchange . . . . .341–342
  - expenses of . . . . .20, 22–23, 25
  - extension . . . . .60–63
  - Federal authority . . . . .2, 29, 156–157
  - forcible opposition to . . . . .21, 23
  - Forest Homestead Entry . . . . .23
  - 14(c) . . . . .337, 340–341
  - fragmentary . . . . .315–318
  - fraudulent . . . . .159–162
  - General Forest Exchange . . . . .341–342
  - Indian Service . . . . .333–334
  - location . . . . .352–353
  - metes-and-bounds . . . . .158, 335–337
  - mine . . . . .347–348
  - mineral . . . . .313–314, 348–349, 351
  - Mineral Leasing Act . . . . .345–347
  - mineral patent application . . . . .353–355
  - National Forest . . . . .23, 342–343
  - nonrectangular . . . . .158, 335–337, 341, 357
  - official . . . . .2, 29, 156–157, 286, 296
  - plane . . . . .31–32, 35–36
  - principles and practices . . . . .3
  - and record systems . . . . .18, 22
  - reliction . . . . .208–209, 212–214
  - reservation . . . . .330
  - segregation . . . . .341–343
  - small tracts . . . . .342–345
  - subdivision by . . . . .68–73
  - townsite . . . . .337–340
  - tract . . . . .137, 160, 177, 292, 342–345
- Survey methods. *See also* Public Land Survey  
System (PLSS); Rectangular surveys,  
system of . . . . .27–38
- apparent misclosure . . . . .31–32
  - arc length . . . . .31
  - areas . . . . .32–33
  - convergency of meridians . . . . .31–32
  - coordinate systems . . . . .34–36
  - curvature . . . . .30–31
  - deflection of the vertical . . . . .33
  - elevation . . . . .33
  - line of constant bearing . . . . .29–30
  - lot and block . . . . .19
  - measurement . . . . .27–28
  - metes-and-bounds . . . . .19
  - parallel lines of PLSS . . . . .33
  - PLSS datum . . . . .28–29, 36–37
  - true meridian . . . . .29
- Surveyor General . . . . .3–4, 8, 18, 20–21, 23
- Swamp lands . . . . .7, 22, 87, 89–90
- ## T
- Table of latitude and departure . . . . .54
- Talweg . . . . .194, 197
- Tectonic change . . . . .199
- Terminal lake . . . . .184
- Terrestrial vegetation . . . . .82, 87–88, 100
- Texas . . . . .17
- Thalweg . . . . .194, 197
- Thread of river . . . . .194, 197
- Three-point proportion . . . . .168
- Tidal flats . . . . .223, 272–282
- Tidelands . . . . .5, 83, 87–88, 189
- Tidewaters . . . . .83, 85, 87–88
- acquired lands . . . . .222–223
  - case studies . . . . .272–282
- Timber lands . . . . .19
- Title of ownership. *See also* Ownership . . . . .64
- Topographic calls . . . . .151–152
- Topographic features . . . . .306–308, 338
- Township . . . . .39–40, 43–60
- aliquot parts . . . . .47–48
  - field notes . . . . .286
  - fractional . . . . .13
  - irregular . . . . .55–57, 59–60
  - lines . . . . .14
  - marking corners . . . . .110, 119, 124
  - numbering . . . . .12, 20
  - plats . . . . .298–299
  - regular . . . . .54–55
  - subdivision . . . . .12, 14, 20, 54–59, 63
  - survey record . . . . .55, 58
  - Tract A . . . . .61
- Township exteriors . . . . .43–54
- allowable deviation . . . . .46–47
  - corners . . . . .12, 43–46, 166–171
  - defective . . . . .50–52, 55–57

error of closure . . . . .50, 54  
 latitudinal boundaries . . . . .44–47, 50–51  
 meridional boundaries . . . . .43–47, 51  
 monumentation . . . . .46  
 official record of . . . . .45  
 partially surveyed . . . . .47  
 protraction diagrams . . . . .45, 50  
 rectangular limits . . . . .48–50  
 resurveys . . . . .50, 139, 142  
 section lines as offsets . . . . .45–46  
 Townsite corners . . . . .148  
 Townsite surveys . . . . .19, 337–340  
 Tract A townships . . . . .61  
 Tracts  
   corners . . . . .148  
   defined . . . . .329  
   French . . . . .21  
   numbering . . . . .142, 163, 329  
   small tract surveys . . . . .342–345  
 Tract segregation. *See* Segregation  
 Tract surveys . . . . .137, 160, 177, 292, 342–345  
 Transitional vegetation . . . . .82  
 Transverse Mercator projection . . . . .35  
 Traverse lines . . . . .72  
 Tree monuments . . . . .118–122  
 Trespass remedy method . . . . .158  
 True corners . . . . .14  
 True lines . . . . .137  
 True meridians . . . . .27–29, 354  
 Tunnel sites . . . . .363  
 Two-point proportion . . . . .168

## U

United States Army Corps of Engineers . . . . .188  
 United States Geological Survey (USGS) . . . . .23, 334  
 United States Indian Service (USIS) surveys . . . . .333–334  
 United States Supervisor of Surveys . . . . .23  
 United States Supreme Court rulings.  
   *See* Case decisions  
 United States Survey Foot . . . . .28, 37  
 Units  
   area . . . . .37  
   bearing . . . . .37  
   linear measure . . . . .37  
   of subdivision . . . . .39–40  
 Unmonumented corners . . . . .148  
 Unofficial boundaries . . . . .143  
 Unsurveyed lands.  
   *See also* Protraction diagrams . . . . .42, 72  
   islands . . . . .22, 24–25, 87, 218, 251–254  
   mineral lands leasing . . . . .346  
   small tracts on . . . . .344

and subdivision . . . . .70–72  
 Upland. *See* Meandering  
 Utah . . . . .17

## V

Vara units . . . . .37–38  
 Vegetation examination . . . . .82–83, 87–88, 90,  
   98–100, 102–103  
 Vertical, deflection of . . . . .33

## W

Washington . . . . .17  
 Water boundaries. *See also* Meandering;  
   Resurveys . . . . .183–224  
     accretion prior to entry . . . . .221, 268–271  
     acquired lands . . . . .222–223  
     alienated lands . . . . .217–218  
     avulsions . . . . .199–205, 232–242  
     erroneous omitted lands . . . . .219–220, 262–267  
     gradual changes in . . . . .242–248  
     inland waters . . . . .184–185  
     islands and sandbars . . . . .22, 24, 86–88,  
       214–215, 218, 248–262  
     lakes . . . . .83–85, 184, 186–187,  
       193, 204, 212–214  
     land outside meanders . . . . .221, 269–271  
     legal effects of changes in . . . . .205–206  
     mineral lands . . . . .222, 271–272  
     navigability . . . . .5, 7–8, 20, 24–26,  
       186–193, 345–346  
     opposite banks delimitations . . . . .194–197  
     partition lines . . . . .209–217  
     and protracted blocks . . . . .77  
     protraction diagrams . . . . .224  
     rivers and tidewaters . . . . .83, 85, 87–88, 184,  
       186–187, 197–200, 204–206, 222–223  
     source of law determination . . . . .193–194  
     State law . . . . .189–190, 193–194, 206–209, 218  
     and subdivision . . . . .66  
     subsurface estate . . . . .207, 222  
     water body movements . . . . .197–209  
 Wisconsin . . . . .17, 90  
 Witness corners . . . . .152  
   accessories . . . . .126  
   defined . . . . .107  
   marks on . . . . .120  
   mineral surveys . . . . .359  
   monumentation . . . . .84, 105, 107, 120, 126  
   witness corner meander corner (WCMC) . . . . .184  
 Witness points . . . . .108, 121, 126, 152, 153  
 Wyoming . . . . .17



**Z**

Zero accretion points (ZAPs) . . . . .210

---

Inside the back cover is a facsimile of the 2009 plat of a township in Alaska surveyed under the public land survey system. The plat represents an original survey executed in accordance with the specifications set forth in the *Manual of Surveying Instructions* and special instructions. The field notes were approved, the plat was accepted, and the survey is officially filed.

The township is designated Township 10 North, Range 80 West, Seward Meridian, counting north and west from the Initial Point of the Seward Principal Meridian and Baseline in Alaska. The basis of location for this survey is the approved Bureau of Land Management Protraction Diagram which provides the plan of survey for land described by aliquot part and referenced to the rectangular survey system. This township was surveyed to accommodate Alaska Native village and regional land selections authorized under the Alaska Native Claims Settlement Act (ANCSA) of December 18, 1971, as amended (85 Stat. 688; 43 U.S.C. 1601 et seq.).

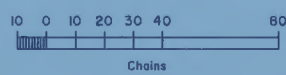
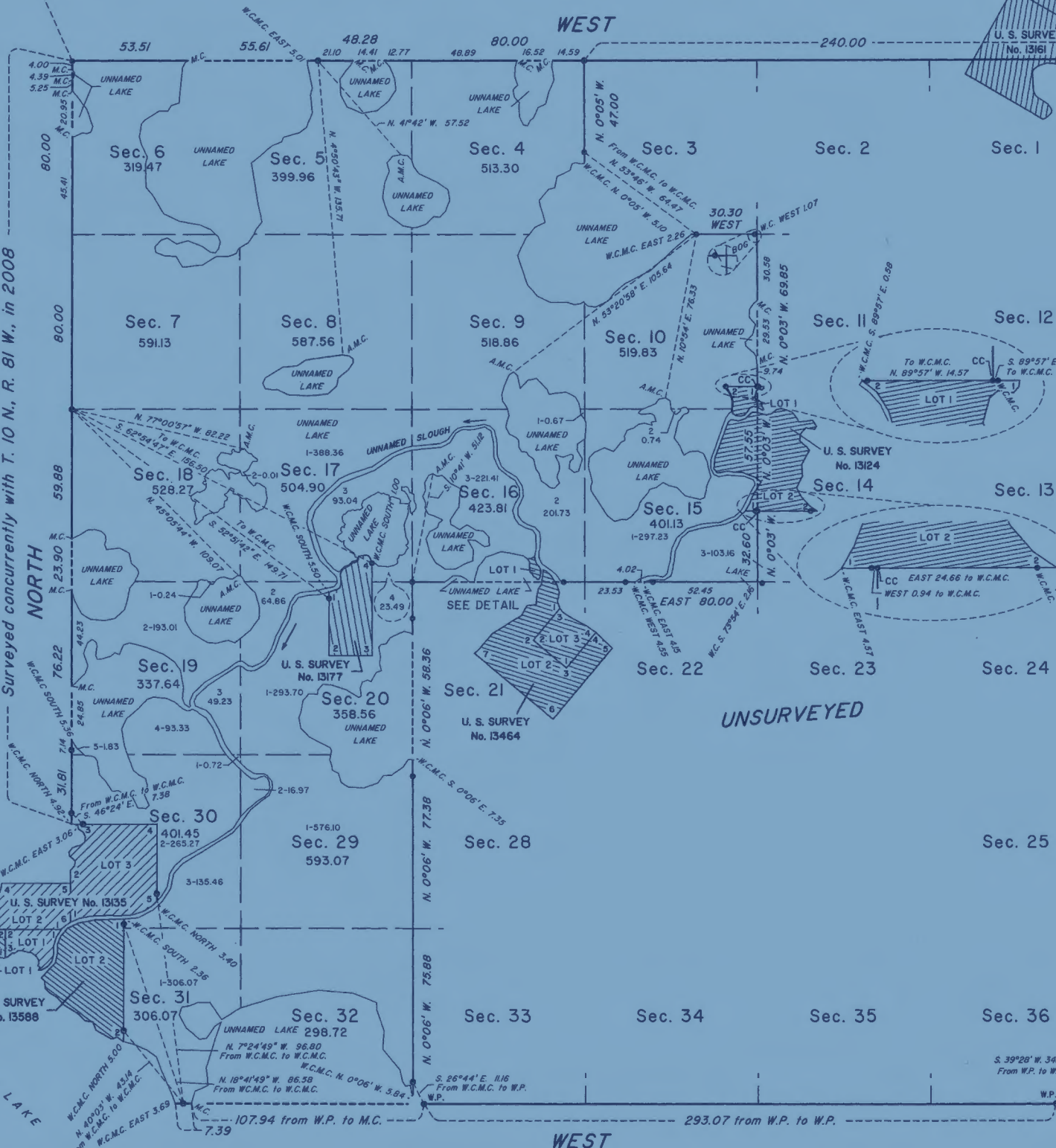
Individual Native allotment parcels and meanderable or navigable water bodies have been segregated within surveyed sections, and lots have been created. Alaska Native allotments were surveyed prior to the township survey as United States (U.S.) Surveys, under the Alaska Native Allotment Act of May 17, 1906, as amended (34 Stat. 197; 43 U.S.C. 270-1 repealed), and are shown as hashed polygons within the township. Under ANCSA, only the exterior boundaries of the selected or designated areas at angle points and at intervals of approximately 2 miles on straight lines are surveyed and marked. Most, but not all, of the township boundary has been returned as surveyed to accommodate the future subdivision of the township, a portion of which remains unsurveyed.

---

# TOWNSHIP 10 NORTH, RANGE 80 WEST, OF THE SEWARD

Surveyed concurrently with T. 11 N., R. 80 W., in 2008

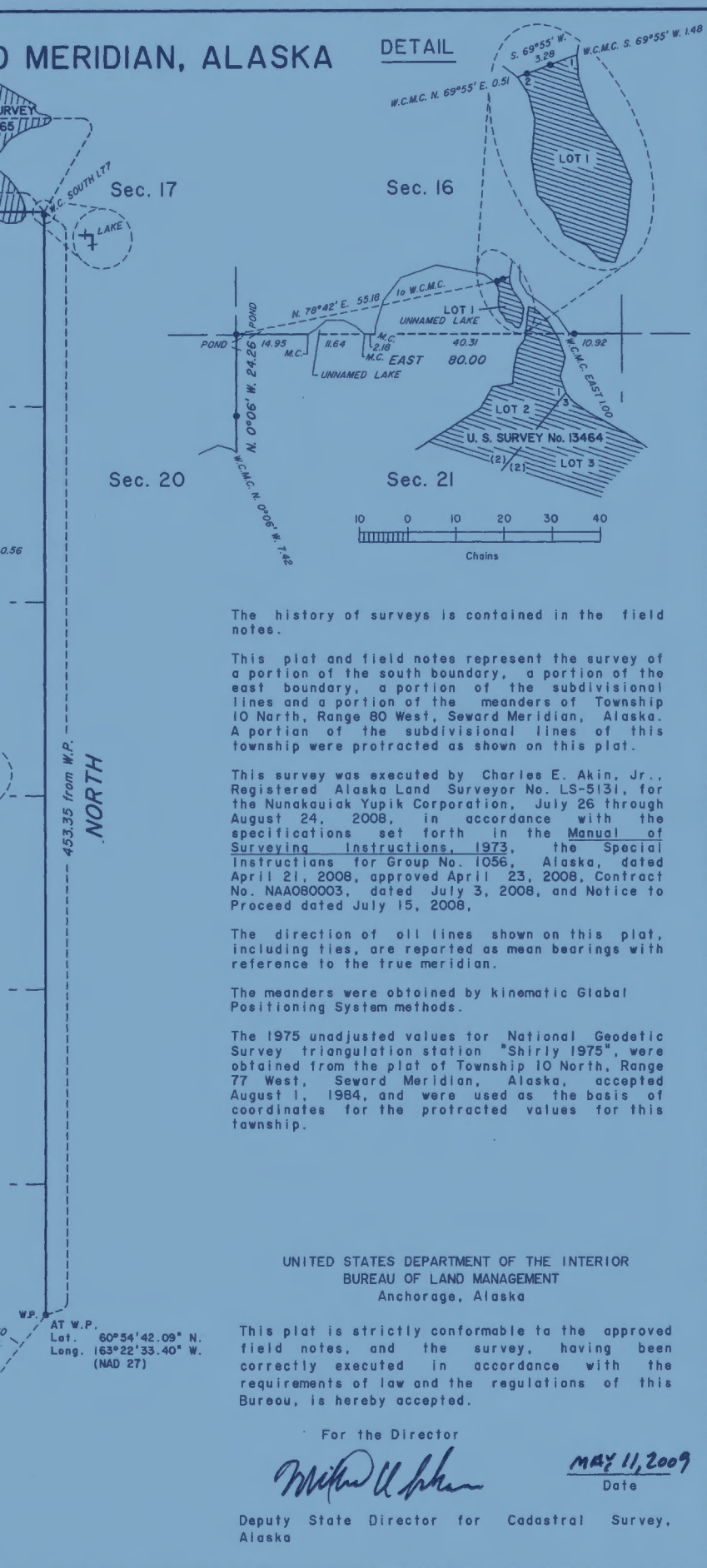
**TWENTIETH GUIDE MERIDIAN WEST**  
 Surveyed concurrently with T. 10 N., R. 81 W., in 2008



Area Surveyed: 7,603.73 Acres

SEWARD MERIDIAN, ALASKA

DETAIL



The history of surveys is contained in the field notes.

This plat and field notes represent the survey of a portion of the south boundary, a portion of the east boundary, a portion of the subdivisional lines and a portion of the meanders of Township 10 North, Range 80 West, Seward Meridian, Alaska. A portion of the subdivisional lines of this township were protracted as shown on this plat.

This survey was executed by Charles E. Akin, Jr., Registered Alaska Land Surveyor No. LS-5131, for the Nunakuiak Yupik Corporation, July 26 through August 24, 2008, in accordance with the specifications set forth in the Manual of Surveying Instructions, 1973, the Special Instructions for Group No. 1056, Alaska, dated April 21, 2008, approved April 23, 2008, Contract No. NAA060003, dated July 3, 2008, and Notice to Proceed dated July 15, 2008.

The direction of all lines shown on this plat, including ties, are reported as mean bearings with reference to the true meridian.

The meanders were obtained by kinematic Global Positioning System methods.

The 1975 unadjusted values for National Geodetic Survey triangulation station "Shirly 1975", were obtained from the plat of Township 10 North, Range 77 West, Seward Meridian, Alaska, accepted August 1, 1984, and were used as the basis of coordinates for the protracted values for this township.

UNITED STATES DEPARTMENT OF THE INTERIOR  
BUREAU OF LAND MANAGEMENT  
Anchorage, Alaska

This plat is strictly conformable to the approved field notes, and the survey, having been correctly executed in accordance with the requirements of law and the regulations of this Bureau, is hereby accepted.

For the Director

*Michael U. Spahn*

MAY 11, 2009  
Date

Deputy State Director for Cadastral Survey,  
Alaska



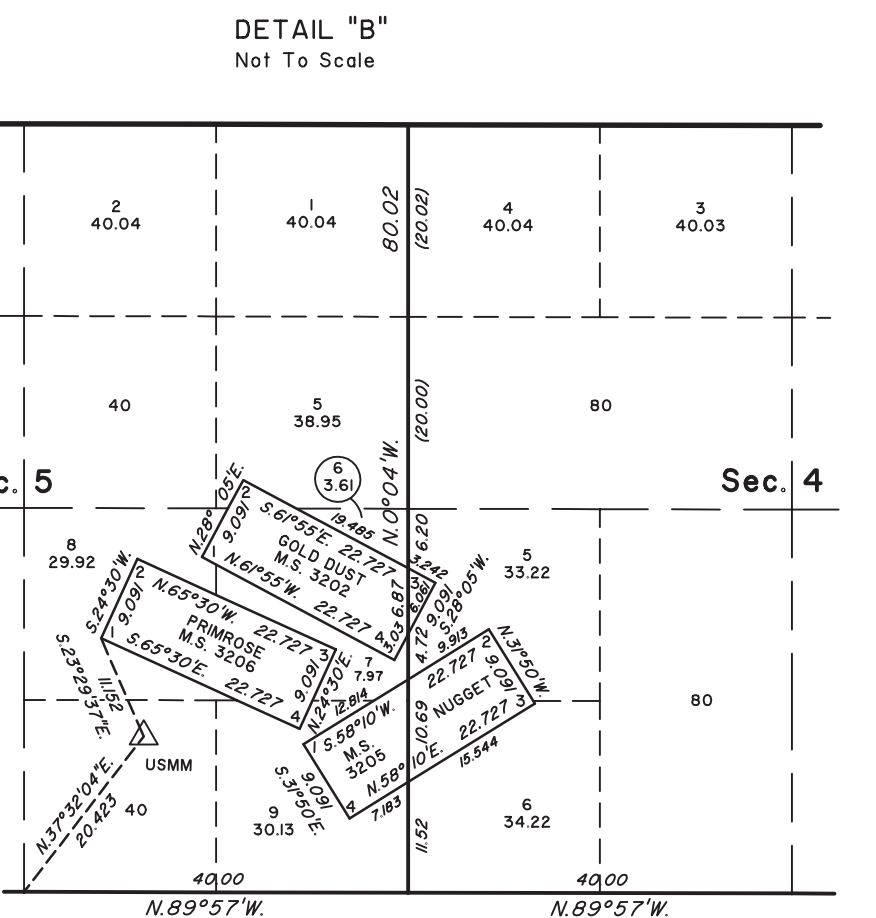
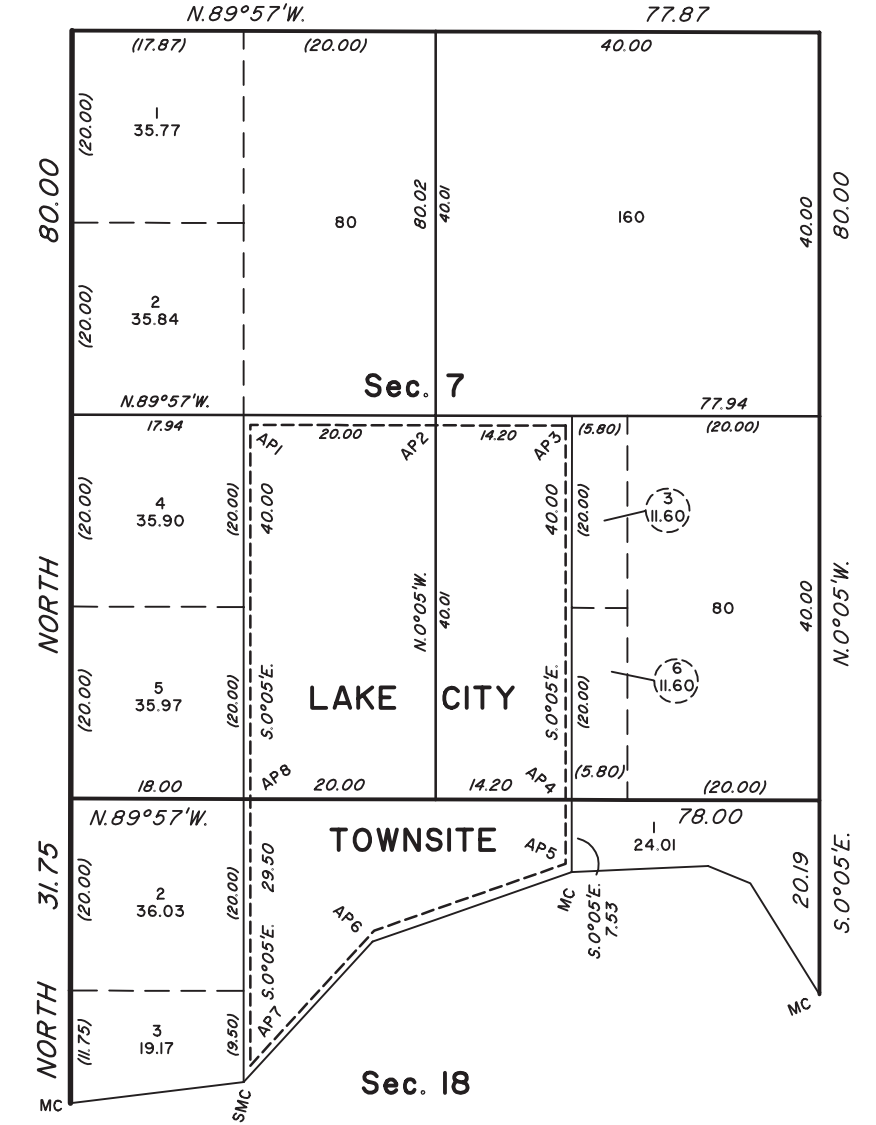
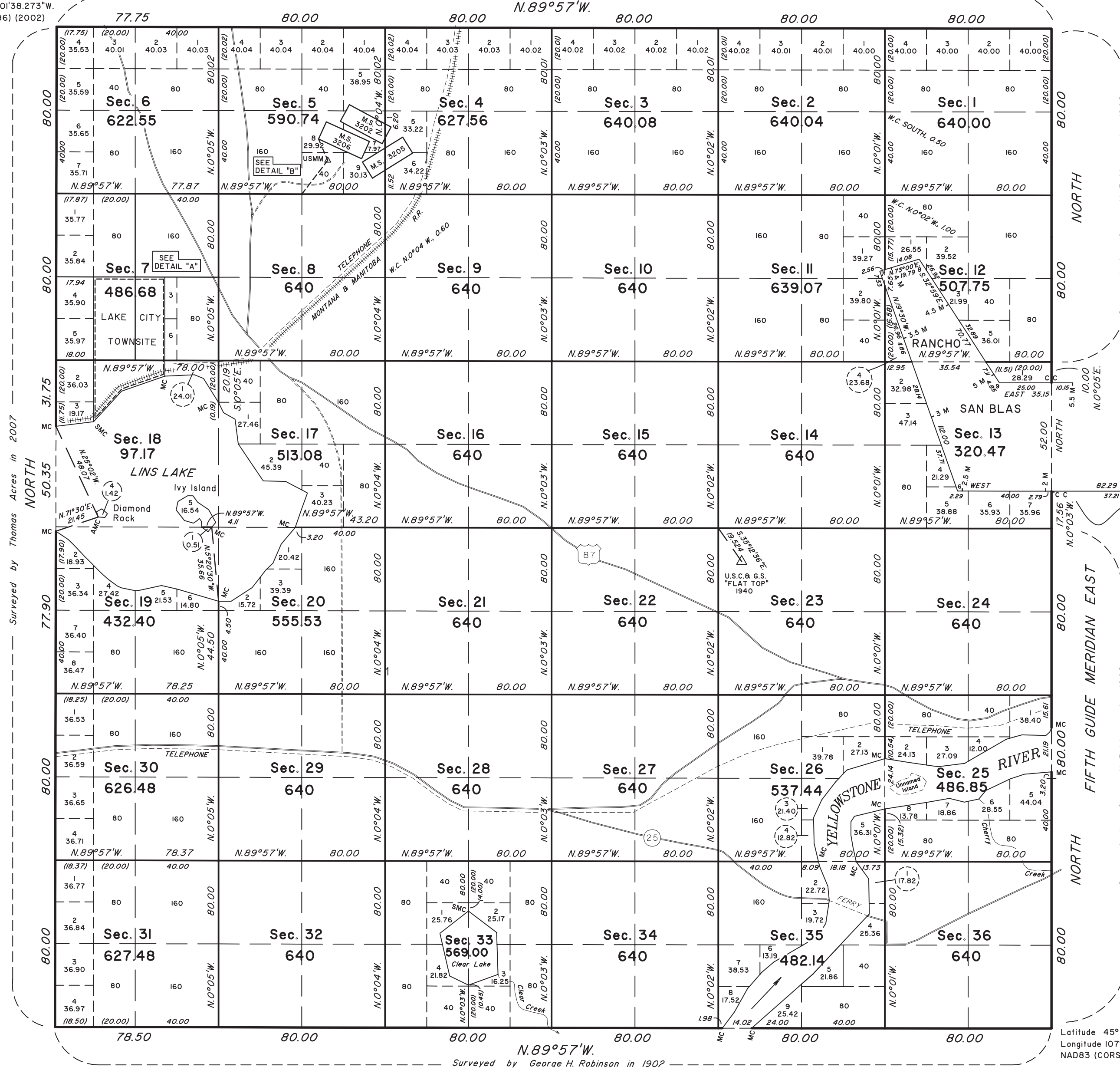
# TOWNSHIP 15 NORTH, RANGE 20 EAST, OF THE PRINCIPAL MERIDIAN, MONTANA

## ORIGINAL SURVEY, DEPENDENT RESURVEY, SUBDIVISION OF SECTIONS, AND TOWNSITE SURVEY

Latitude 45°50'15.065"N.  
Longitude 108°01'38.273"W.  
NAD83 (CORS96) (2002)

Surveyed by Thomas Acres in 2007

DETAIL "A"  
Not To Scale



UNITED STATES DEPARTMENT OF THE INTERIOR  
BUREAU OF LAND MANAGEMENT  
Billings, Montana September 15, 2009

This plat is strictly conformable to the approved field notes, and the survey, having been correctly executed in accordance with the requirements of the law and the regulations of this Bureau, is hereby accepted.

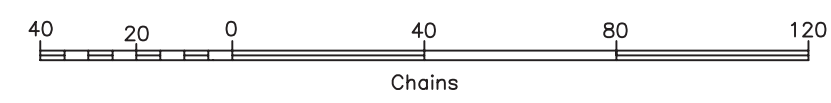
For the Director

Chief Cadastral Surveyor for Montana

The history of surveys is contained in the field notes.

This plat represents the dependent resurvey of a portion of Rancho San Blas, Mineral Surveys No. 3202, 3205, and 3206, and a portion of the east boundary, and survey of the subdivisional and meander lines, subdivision of sections 7, 18, and 33, and Lake City Townsite of Township 15 North, Range 20 East, Principal Meridian, Montana, executed by Robert Acres, Cadastral Surveyor, beginning June 1, 2009 and completed June 30, 2009, under Special Instructions dated April 1, 2009, for Group No. 1234, Montana.

Area surveyed: 20,882.51 acres



Latitude 45°45'02.458"N.  
Longitude 107°54'13.367"W.  
NAD83 (CORS96) (2002)



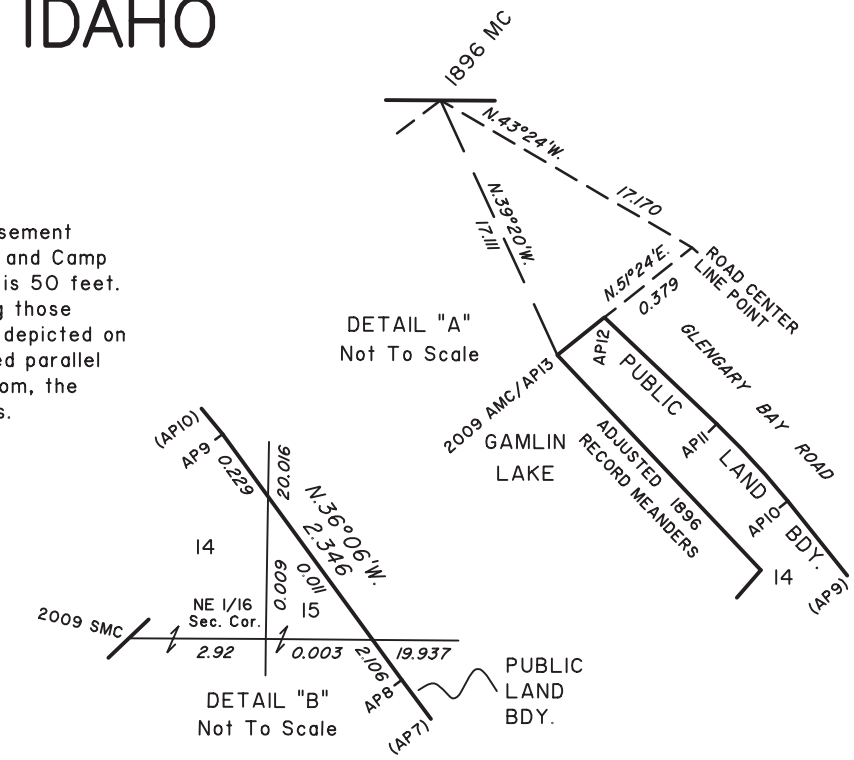
# TOWNSHIP 5 SOUTH, RANGE 7 EAST, OF THE BOISE MERIDIAN, IDAHO

## DEPENDENT RESURVEY, SUBDIVISION OF SECTIONS, AND SURVEY

AREA OF FEDERAL INTEREST LAND RESURVEYED

SECTION	LOCATION	ACREAGE
30	SW 1/4 SE 1/4	40.26
31	NE 1/4 NE 1/4	39.93
31	NW 1/4 NE 1/4	40.03
31	SE 1/4 SE 1/4	40.07
31	NE 1/4 NW 1/4	39.81
31	SE 1/4 NW 1/4	39.87

NOTE: The prescriptive easement width of Glengary Bay Road and Camp Bay Road within section 30 is 50 feet. The right-of-way lines along those portions of these roads, as depicted on this plat, have been surveyed parallel with, and 25 feet distant from, the present as-built center lines.



A history of surveys is contained in the field notes.

This plat represents the dependent resurvey of portions of the south and west boundaries of the township, the subdivisional lines, the adjusted 1896 record meanders of Gamlin Lake in section 30, and the 1910 meanders of the left bank of the Snake River in section 31, designed to restore the corners in their true original locations according to the best available evidence, and the subdivision of sections 30 and 31, the survey of an unnamed island within Gamlin Lake in section 30, the survey of the meanders of the right bank of the Snake River in section 31, the public land boundary in the E1/2 of section 30, the right-of-way lines of Camp Bay Road in the SW1/4 of section 30, Lot 12 in the NW1/4 of section 30, and Parcel A in section 31, T. 5 S., R. 7 E., Boise Meridian, Idaho.

Except as depicted hereon, the lottings and areas are as shown on the plats accepted September 23, 1897 and July 29, 1911.

No determination of the ownership status of two islands, located on the line between sections 31 and 32 in the Snake River, is made at this time. Willow brush, scattered box elder, and Russian olive trees are present on the two islands.

Survey executed by Victoria M. Caldwell, Cadastral Surveyor, beginning May 5, 2009 and completed September 4, 2009, pursuant to special instructions dated May 1, 2009, and supplemental special instructions dated July 20, 2009, for Group No. 2222, Idaho.

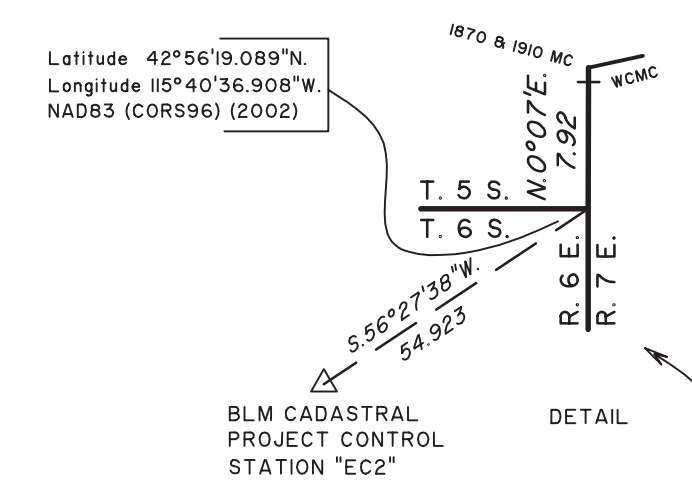
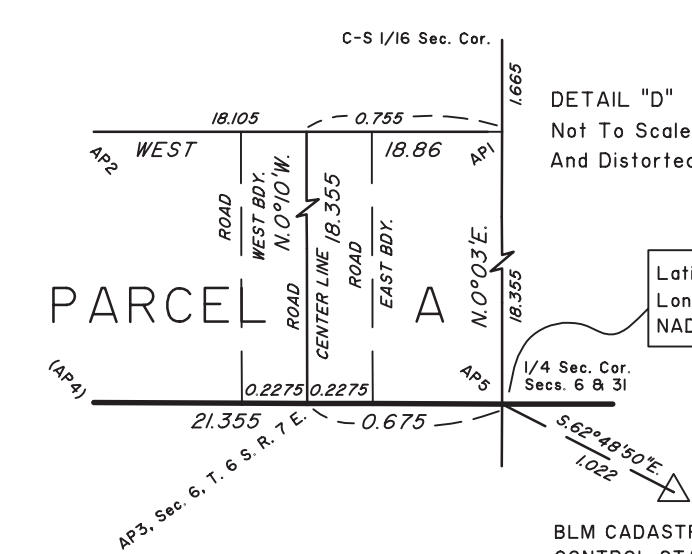
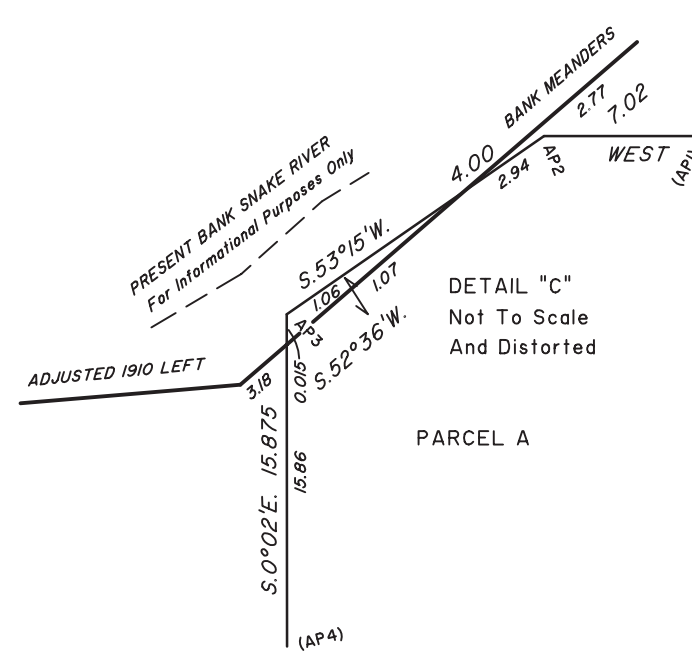
UNITED STATES DEPARTMENT OF THE INTERIOR  
BUREAU OF LAND MANAGEMENT

Boise, Idaho June 18, 2010

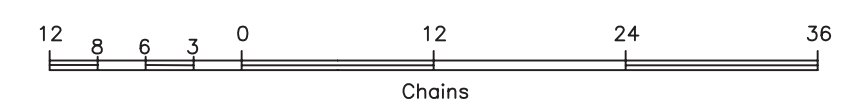
This plat is strictly conformable to the approved field notes, and the survey, having been correctly executed in accordance with the requirements of law and the regulations of this Bureau, is hereby accepted.

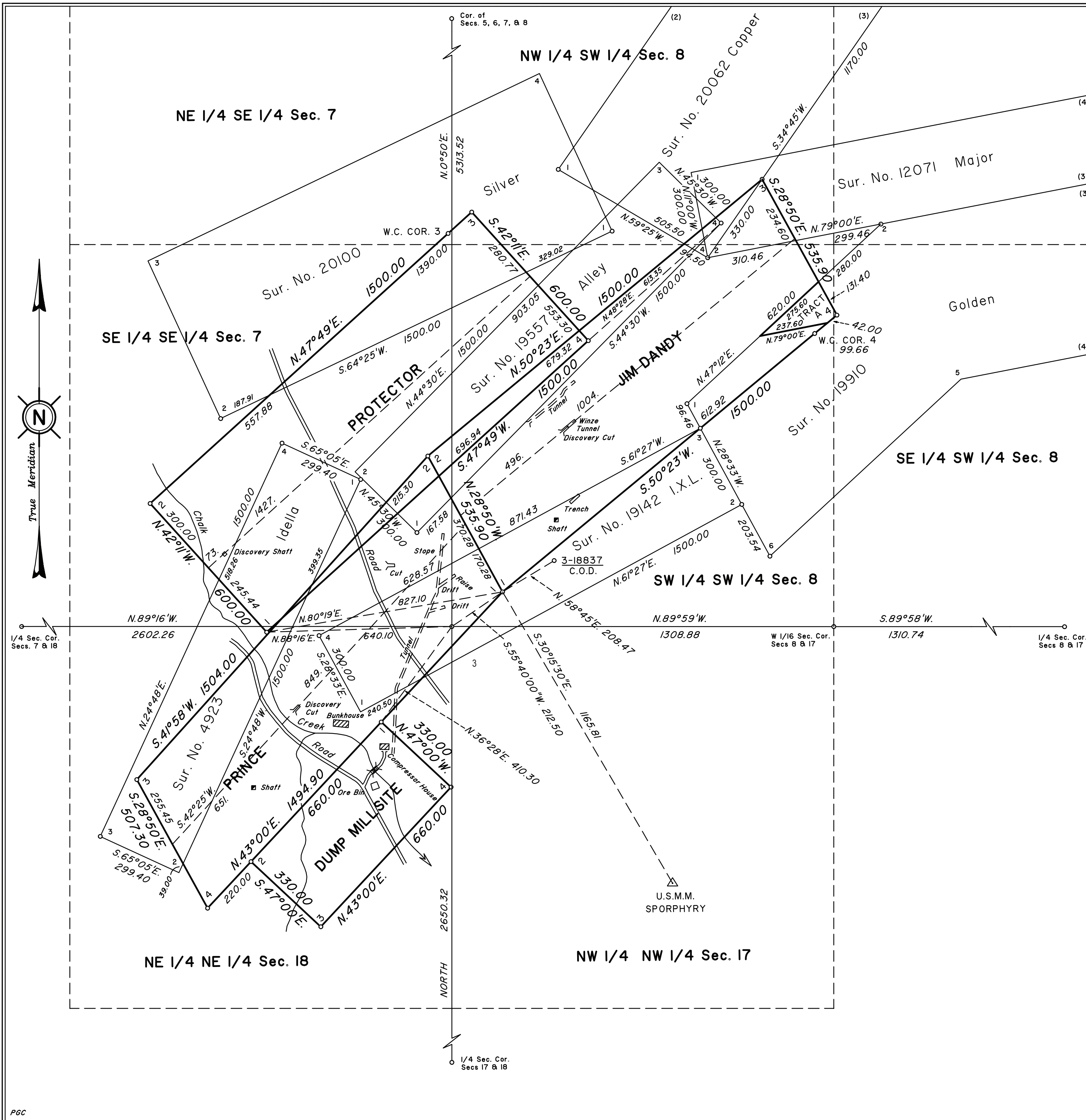
For the Director

Chief Cadastral Surveyor for Idaho



TOTAL AREA OF FEDERAL INTEREST LAND SURVEYED = 0.84 ACRES  
TOTAL AREA OF FEDERAL INTEREST LAND RESURVEYED = 705.85 ACRES





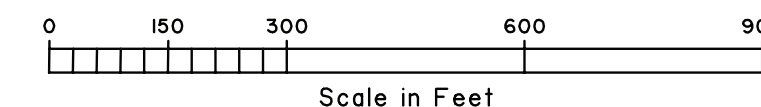
**MINERAL SURVEY  
NO. 20220 A & B  
COLORADO**

CLAIM OF  
**THE GOLD MINING COMPANY**

KNOWN AS THE  
**JIM DANDY, PRINCE AND  
PROTECTOR LODES AND  
DUMP MILLSITE**

SITUATE IN  
**Secs. 7, 8, 17, & 18, T. 16 S., R. 80 W., 6th P. M.  
CHAFFEE COUNTY  
Cottonwood Mining District  
Pueblo Land District**

Lat. 38°45'01.017"N., Long. 106°20'02.029"W.,  
NAD83 (CORS96) (EPOCH:2002)  
at Cor. No. 1, JIM DANDY Lode



Magnetic Declination, 13° East

Surveyed, May 11 to May 15, 2009,  
by H. B. Sands, Mineral Surveyor

UNITED STATES DEPARTMENT OF THE INTERIOR  
BUREAU OF LAND MANAGEMENT

Denver, Colorado June 22, 2009

I hereby certify that this plat of Mineral Survey No. 20220 A & B, Colorado, is strictly conformable to the approved field notes and the survey, having been correctly executed in accordance with the requirements of law and the regulations of this Bureau, is hereby accepted.

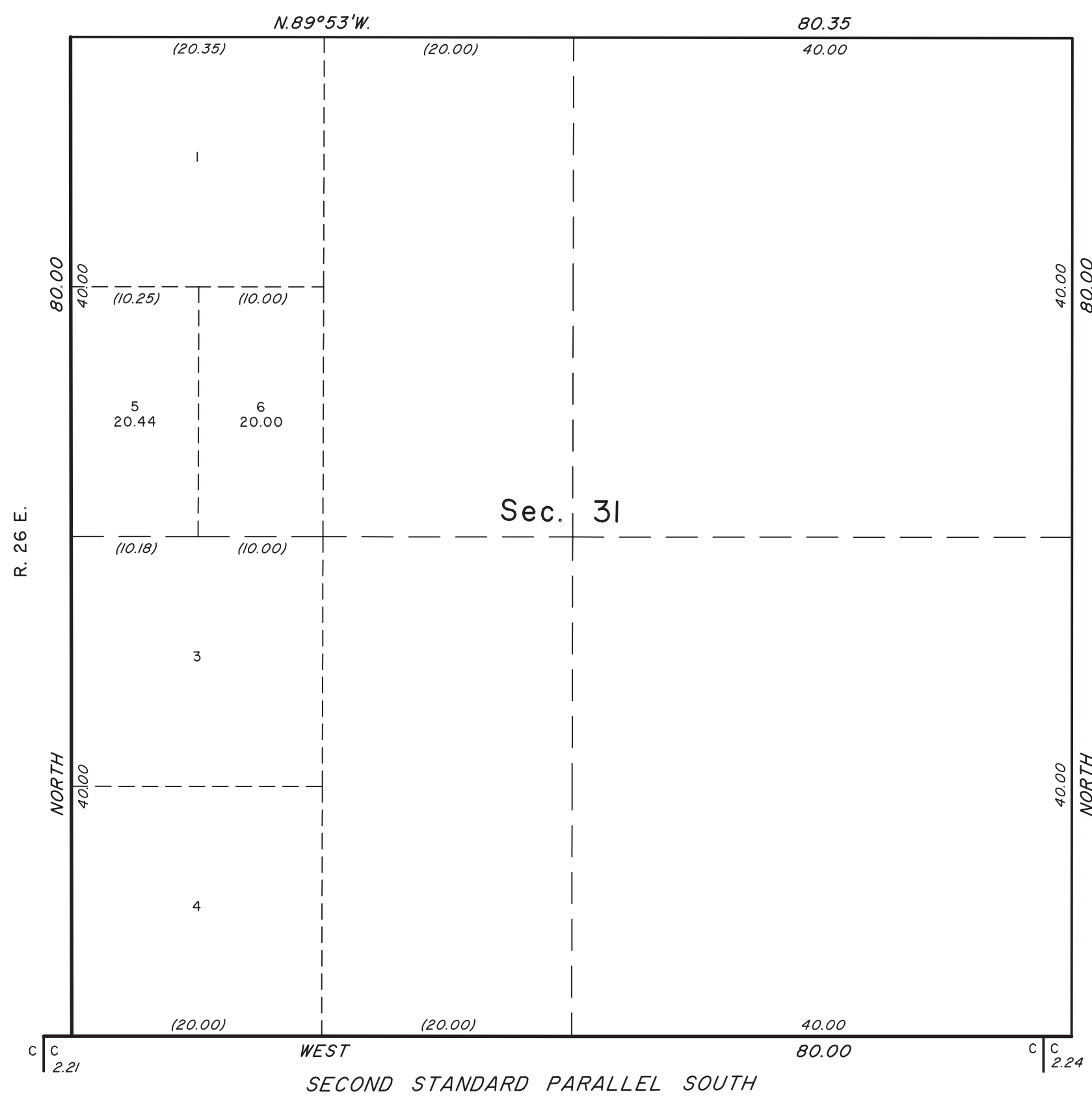
For the Director

Chief Cadastral Surveyor for Colorado



TOWNSHIP 8 SOUTH, RANGE 27 EAST, OF THE SALT LAKE MERIDIAN, UTAH  
SUPPLEMENTAL PLAT

Sec. 30



This plat, showing a subdivision of original lot 2, section 31, T. 8 S., R. 27 E., Salt Lake Meridian, Utah, is based upon the plat approved September 4, 1879, and is prepared to accommodate Federal Land Policy and Management Act sale UTUT-155003. Plat prepared by Ernest P. Rands, Cadastral Surveyor, beginning May 18, 2009, and completed June 1, 2009, pursuant to special instructions dated and approved May 14, 2009, and assignment instructions dated May 15, 2009, for Group No. 5132, Utah.

Except as depicted hereon, the lotting and areas are as shown on the plat approved September 4, 1879.

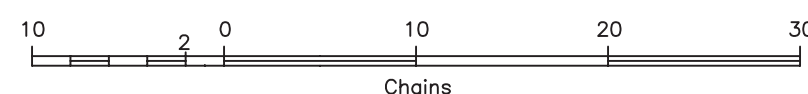
UNITED STATES DEPARTMENT OF THE INTERIOR  
BUREAU OF LAND MANAGEMENT

Salt Lake City, Utah June 20, 2009

This plat, showing amended lottings, is based upon the official records, and having been correctly prepared in accordance with the requirements of the law and the regulations of this Bureau, is hereby accepted.

For the Director

Chief Cadastral Surveyor for Utah



TOWNSHIP 10 NORTH, RANGE 56 EAST, OF THE BOISE MERIDIAN, IDAHO

PROTRACTION DIAGRAM  
UNSURVEYED

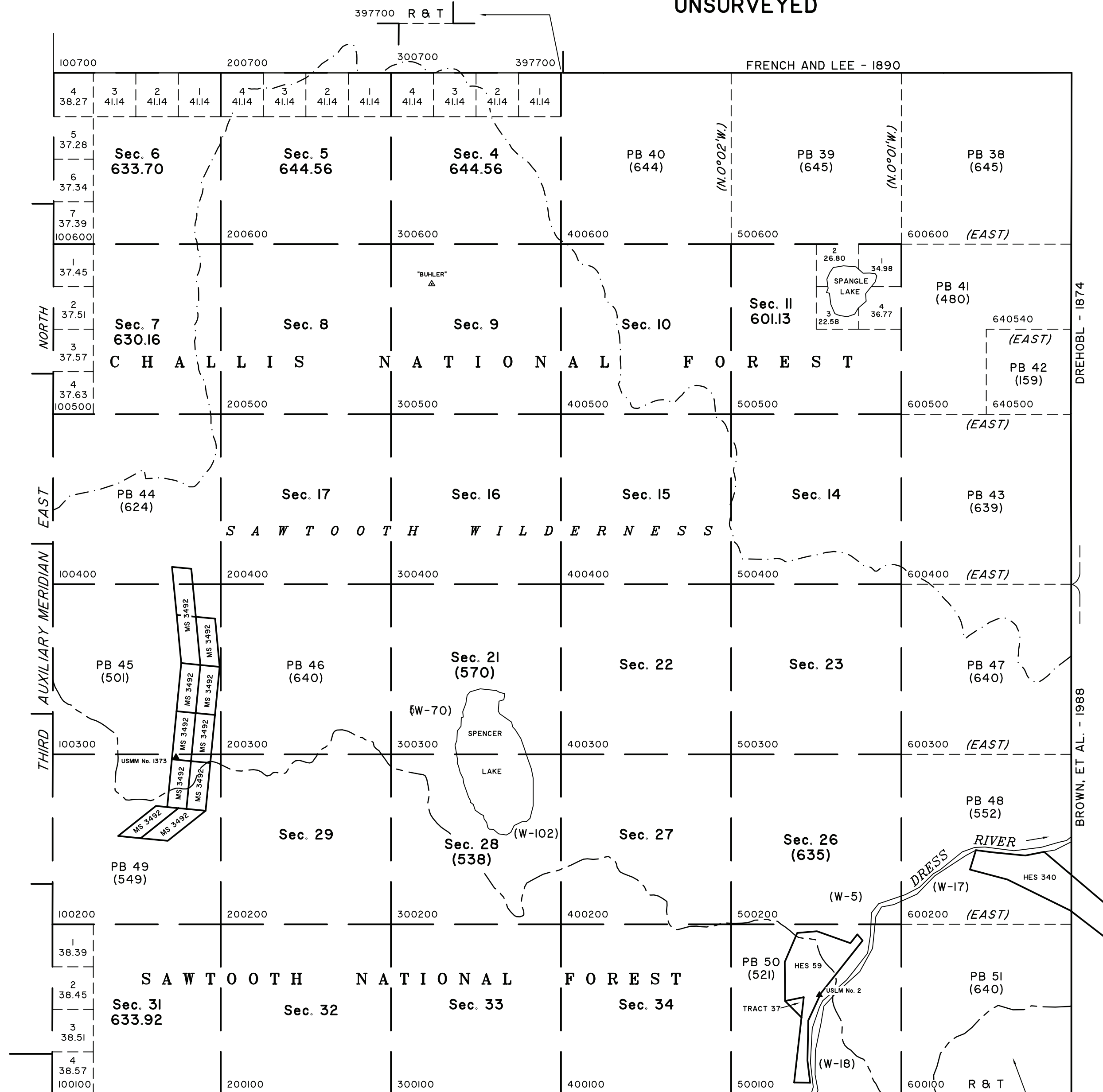
This protraction diagram was prepared for the express purpose of describing unsurveyed public land. It does not constitute an official survey but establishes the plan for extending the rectangular survey system over these unsurveyed lands and may be used for leasing and administrative purposes only.

The actual area of protracted blocks (PB) shown on this diagram may vary due to the reliability of the survey information used to determine the positions of existing survey boundaries. A protracted block cannot be subdivided without an official survey. Unless otherwise shown, each unsurveyed section, designated Sec. on the diagram, contains 640 acres. The sections and lots on this diagram depict how the area may be surveyed; but until that time they will continue to be unsurveyed lands. Data shown in parenthesis ( ) are proposed information for the plan of survey and subject to change.

This protraction diagram officially supersedes the existing protraction for this area, except where existing rights or administrative actions based upon the existing protraction are not adequately protected.

Latitudes and longitudes were computed to portray standard protracted sections using an elevation of 7000 feet for this township.

Diagram prepared by Mary M. Belle, Cadastral Surveyor, beginning July 31, 2009, and completed September 4, 2009, pursuant to special instructions dated and approved April 1, 2009, and assignment instructions dated June 4, 2009, for Group No. 2345, Idaho.



NAD 1983		
Point ID	Latitude	Longitude
100100	44°08'42.2204"	115°07'00.0534"
100200	44°09'34.3439"	115°07'00.0534"
100300	44°10'26.4673"	115°07'00.0534"
100400	44°11'18.5905"	115°07'00.0534"
100500	44°12'10.7135"	115°07'00.0534"
100600	44°13'02.8365"	115°07'00.0534"
100700	44°13'55.3293"	115°07'00.0534"
200100	44°08'42.2204"	115°05'48.3020"
200200	44°09'34.3439"	115°05'48.3905"
200300	44°10'26.4673"	115°05'48.4791"
200400	44°11'18.5905"	115°05'48.5677"
200500	44°12'10.7135"	115°05'48.6564"
200600	44°13'02.8365"	115°05'48.7452"
200700	44°13'55.3293"	115°05'48.8347"
300100	44°08'42.2204"	115°04'35.9152"
300200	44°09'34.3439"	115°04'35.9860"
300300	44°10'26.4673"	115°04'36.0568"
300400	44°11'18.5905"	115°04'36.1277"
300500	44°12'10.7135"	115°04'36.1987"
300600	44°13'02.8365"	115°04'36.2697"
300700	44°13'55.3293"	115°04'36.3412"
397700	44°13'55.3293"	115°03'23.8480"
400100	44°08'42.2204"	115°03'23.5283"
400200	44°09'34.3439"	115°03'23.5914"
400300	44°10'26.4673"	115°03'23.6345"
400400	44°11'18.5905"	115°03'23.6877"
400500	44°12'10.7135"	115°03'23.7409"
400600	44°13'02.8365"	115°03'23.7942"
500100	44°08'42.2204"	115°02'11.1414"
500200	44°09'34.3439"	115°02'11.1768"
500300	44°10'26.4673"	115°02'11.2122"
500400	44°11'18.5905"	115°02'11.2477"
500500	44°12'10.7135"	115°02'11.2832"
500600	44°13'02.8365"	115°02'11.3187"
600100	44°08'42.2204"	115°00'58.7546"
600200	44°09'34.3439"	115°00'58.7723"
600300	44°10'26.4673"	115°00'58.7900"
600400	44°11'18.5905"	115°00'58.8077"
600500	44°12'10.7135"	115°00'58.8254"
600600	44°13'02.8365"	115°00'58.8432"
640500	44°12'10.7135"	115°00'22.5966"
640540	44°12'36.7750"	115°00'22.6010"

UNITED STATES DEPARTMENT OF THE INTERIOR  
BUREAU OF LAND MANAGEMENT

Boise, Idaho October 5, 2009

This diagram represents the official protraction of the rectangular system of surveys and is hereby accepted.

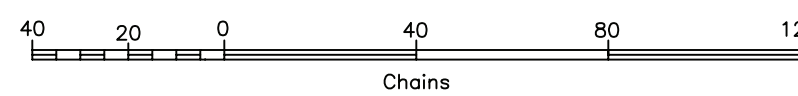
For the Director

Chief Cadastral Surveyor for Idaho

LEGEND

- Surveied Lines
- Reliable Protracted Lines
- - - Protracted Lines
- - - R & T
- - - National Forest Boundary
- - - Wilderness Boundary
- (W-26) Water Area

Area Protracted: 22,621.90 acres



SAWTOOTH NATIONAL  
FOREST

AREA OF FEDERAL INTEREST LAND  
RESURVEYED

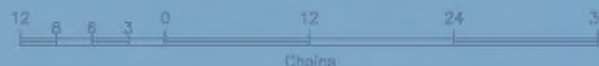
SECTION	LOCATION	ACREAGE
30	SW 1/4 SE 1/4	40.26
31	NE 1/4 NE 1/4	39.93
31	NW 1/4 NE 1/4	40.03
31	SE 1/4 SE 1/4	40.07
31	NE 1/4 NW 1/4	39.81
31	SE 1/4 NW 1/4	39.87



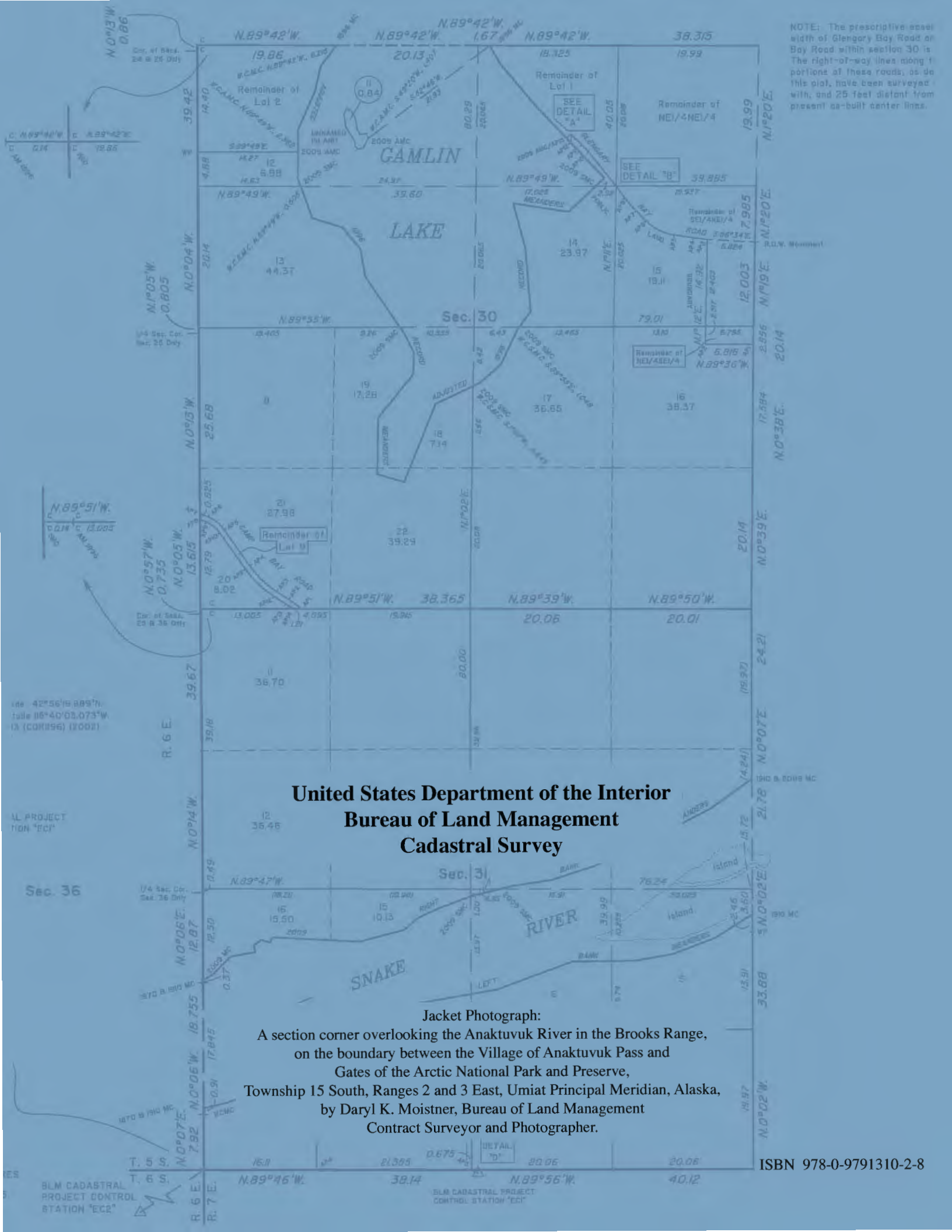
The Department of the Interior manages about 500 million acres, or one-fifth, of the land in the United States. The Bureau of Land Management administers over half of this land—256 million acres—which is more land than is managed by any other Federal agency. This land is primarily located in 12 Western States, including Alaska. The BLM also administers 700 million acres of subsurface mineral estate in all 50 States. The BLM’s mission is to sustain the health and productivity of the public lands for the use and enjoyment of present and future generations. For example, the BLM manages public lands used for outdoor recreation, livestock grazing, and energy production and conserves natural, historical, and cultural resources on public lands.

The BLM is the Nation’s surveyor and maintains extensive current and historical information about land ownership in the United States. Most title to land, public or private, begins with a land description established by an original cadastral survey, possibly dating back to 1785. Security of legal title to land is the fundamental object of the cadastral surveyor’s work and of this Manual. The Manual describes how cadastral surveys are made in conformance with statutory law and its judicial interpretation.

TOTAL AREA OF FEDERAL INTEREST LAND SURVEYED = 0.64 ACRES  
TOTAL AREA OF FEDERAL INTEREST LAND RESURVEYED = 705.85 ACR







NOTE: The prescriptive easel width of Glenagary Bay Road on Bay Road within section 30 is. The right-of-way lines along portions of these roads, as do this plat, have been surveyed with, and 25 feet distant from present as-built center lines.

**United States Department of the Interior  
Bureau of Land Management  
Cadastral Survey**

**Jacket Photograph:**  
A section corner overlooking the Anaktuvuk River in the Brooks Range, on the boundary between the Village of Anaktuvuk Pass and Gates of the Arctic National Park and Preserve, Township 15 South, Ranges 2 and 3 East, Umiat Principal Meridian, Alaska, by Daryl K. Moistner, Bureau of Land Management Contract Surveyor and Photographer.

42°56'0.889"N  
116°40'03.073"W  
13 (CORR96) (2002)

BLM PROJECT CONTROL STATION "EC1"

BLM CADASTRAL PROJECT CONTROL STATION "EC2"

BLM CADASTRAL PROJECT CONTROL STATION "EC1"